

SPACE42

THURAYA

IP NEO M

User manual



Document number: 98-188247-B

Release date: 9 July 2025

Disclaimer

Any responsibility or liability for loss or damage in connection with the use of this product and the accompanying documentation is disclaimed by Thrane & Thrane A/S. The information in this manual is provided for information purposes only, is subject to change without notice and may contain errors or inaccuracies. Manuals issued by Thrane & Thrane A/S are periodically revised and updated. Anyone relying on this information should acquire the most current version e.g. from the partner portal at <https://partnerportal.cobhamsatcom.com/eshop/downloads>, or from the distributor. Thrane & Thrane A/S is not responsible for the content or accuracy of any translations or reproductions, in whole or in part, of this manual from any other source. In the event of any discrepancies, the English version shall be the governing text.

Thrane & Thrane A/S is trading as Cobham Satcom.

Copyright

© 2025 Thrane & Thrane A/S. All rights reserved.

Manufacturer address

Thrane & Thrane A/S, Lundtoftegårdsvej 93 D, DK-2800, Kgs. Lyngby, Denmark

Trademark acknowledgments

- **SPACE42** is a trademark of BAYANAT INVESTMENTS LTD.
- **Thuraya** is a registered trademark of Thuraya Satellite Telecommunications Company.
- Other product and company names mentioned in this manual may be trademarks or trade names of their respective owners.

Safety summary

The following general safety precautions must be observed during all phases of operation, service and repair of this equipment. Failure to comply with these precautions or with specific warnings elsewhere in this manual violates safety standards of design, manufacture and intended use of the equipment. Cobham Satcom assumes no liability for the customer's failure to comply with these requirements.

Do not operate in an explosive atmosphere

Do not operate the equipment in the presence of flammable gases or fumes. Operation of any electrical equipment in such an environment constitutes a definite safety hazard.

Keep away from live circuits

Operating personnel must not remove equipment covers. Component replacement and internal adjustment must be made by qualified maintenance personnel. Do not replace components with the power cable connected. Under certain conditions, dangerous voltages may exist even with the power cable removed. To avoid injuries, always disconnect power and discharge circuits before touching them.

Do not service alone

Do not attempt internal service or adjustments unless another person, capable of rendering first aid resuscitation, is present.

Do not substitute parts or modify equipment

Because of the danger of introducing additional hazards, do not substitute parts or perform any unauthorized modification to the equipment.

Keep away from antenna front

This device emits radio frequency energy when switched on. To avoid injury, keep a minimum safety distance of 60 cm from the antenna front when the IP NEO M is on.

Garder à l'écart de l'avant de l'antenne

Le présent appareil émet des radiofréquences lors de son utilisation. Afin d'éviter tout risque pour la santé, une distance minimale de 60 cm est nécessaire entre l'utilisateur et l'avant de la IP NEO M.

Only use approved batteries from Cobham Satcom

Use of non approved batteries may result in explosion, fire, electrical shock or injury.



Antenna safety instructions

Use only manufacturer supplied antennas.

Antenna minimum safe distance: 0.6 m

Antenna mounting

The antenna supplied by the manufacturer must be located such that during radio transmission, no person or persons can come closer than the above indicated minimum safe distance to the front face of the antenna, i.e. 0.6 m.

L'antenne fournie par le fabricant doit être placée de telle sorte que, durant les transmissions radio, personne ni aucun groupe de personnes ne puisse s'approcher à une distance inférieure à la distance de sécurité minimal indiquée ci-dessus, c.-à-d., 0.6 m.

To comply with current FCC RF Exposure limits, the antenna must be installed at or exceeding the minimum safe distance shown above, and in accordance with the requirements of the antenna manufacturer or supplier.

Radiation warning



WARNING! Maintain a separation distance of at least 0.6 m from the front face of the antenna to a person.

You, as the qualified end-user of this radio device, must control the exposure conditions of bystanders to ensure the minimum separation distance (above) is maintained between the antenna and nearby persons, for satisfying RF Exposure compliance. The operation of this transmitter must satisfy the requirements of General Population/ Uncontrolled Environment. Only use the terminal when persons are at least the minimum distance from the front face of the antenna.

About this manual

Intended readers

This manual is a user manual for the IP NEO M. The manual is intended for anyone who is using or intends to use the IP NEO M. No specific skills are required to operate the IP NEO M. However, it is important that you observe all safety requirements listed in the **Safety summary** in the beginning of this manual, and operate the IP NEO M according to the guidelines in this manual.

Related documents

The following documents are related to this manual and to the IP NEO M system.

Title and description	Document number
IP NEO M Getting Started	98-188248
IP NEO M REST API documentation	98-182365
Space42 IP Handset User manual	98-188255

Typography

In this manual, typography is used as indicated below:

Bold is used for the following purposes:

- To emphasize words.
Example: “Do **not** touch the antenna front during pointing”.
- To indicate what the user should select in the user interface.
Example: “Select **Control panel** > **WLAN** and click **Enable**”.

Italic is used to emphasize the paragraph title in cross-references.

Example: “For further information, see *Connecting Cables* on page...”.

Contents

Chapter 1	Introduction to IP NEO M	
1.1	General description	1-1
1.2	Features and interfaces of the IP NEO M	1-2
1.3	Your IP NEO M terminal	1-3
1.4	Part numbers	1-5
Chapter 2	Operation	
2.1	To get started	2-1
2.2	To connect cables	2-4
2.3	To switch the IP NEO M on or off	2-7
2.4	To connect using WLAN	2-7
2.5	To access the web interface	2-8
2.6	To access the external network	2-9
2.7	Data connection	2-12
2.8	To make phone calls over satellite (only with T4-NGS)	2-16
2.9	Push-To-Talk (PTT) (only with T4-NGS)	2-19
2.10	Stealth mode	2-19
2.11	Alerts	2-20
2.12	Status of the IP NEO M	2-20
Chapter 3	Configuration	
3.1	The web interface	3-2
3.2	To point the antenna	3-6
3.3	To enter the SIM PIN in the web interface	3-7
3.4	To control data connections from web interface	3-8
3.5	Status information	3-11
3.6	The Control panel	3-12
3.7	To select the satellite network	3-13
3.8	To activate Stealth mode	3-13
3.9	To use the logs	3-13
3.10	Battery status information	3-15
3.11	To set up the interfaces	3-16
3.12	Voice setup	3-18
3.13	Support features	3-19
3.14	Terminal settings	3-21
3.15	Advanced LAN	3-25
3.16	Advanced settings	3-26

Chapter 4	Maintenance and troubleshooting	
4.1	Support	4-1
4.2	Software update	4-2
4.3	Restore the settings of the IP NEO M	4-4
4.4	Maintenance	4-5
4.5	Troubleshooting	4-7
4.6	Log files	4-17
Appendix A	Technical specifications	
A.1	General specifications	A-1
A.2	Battery specifications (internal battery)	A-2
A.3	Interfaces specifications	A-3
A.4	Built-in satellite antenna	A-4
A.5	Outline drawing	A-5
Appendix B	Command reference	
B.1	Overview of AT commands	B-2
B.2	AT commands	B-3
B.3	Configuration examples	B-10
Appendix C	List of default settings	
Appendix D	Conformity	
D.1	CE	D-1
D.2	RCM, Australia	D-1
D.3	FCC	D-1
D.4	Safety CB certificate	D-2
Glossary	Glossary-1
Index	Index-1

Introduction to IP NEO M

1.1 General description

The IP NEO M is a very small, lightweight, portable satellite terminal. It provides simultaneous high quality voice¹ and broadband access at speeds up to 1 Mbps².

The durable casing and a dust and water resistant design makes the IP NEO M the perfect choice when working in harsh environments off the beaten track but still dependent on a reliable connection.



Your equipment connects to the IP NEO M with LAN or wireless LAN (WLAN).

The IP NEO M provides access to Voice¹ and up to 444 kbps/1 Mbps² Standard data and 16, 32, 64, 128, 256, 384, 512, 768 and 1024 kbps Streaming data (symmetric or asymmetric) and may be used for:

- Broadcasting
- Network browsing
- E-mail
- Phone services (using WLAN or LAN with Voice over LTE)¹
- PTT with Space42 IP Handset³
- File transfers
- Video conference and Streaming
- VPN (Virtual Private Network) access to corporate servers

The IP NEO M can withstand severe environmental conditions such as humidity, dust, extreme weather and changing temperatures. It is small in size and fits easily into a backpack or similar.

1. Voice is only available when connected to T4-NGS network.
2. For T2/T3 network, the max speed is 444 kbps (max. Streaming rate 384 kbps).
3. Only when connected to T4-NGS network.

1.2 Features and interfaces of the IP NEO M

1.2.1 Features

- Lightweight and small satellite terminal with built-in battery.
- Portable operation using built-in rechargeable battery or external battery pack for longer use sessions.
- Alternative power options:
 - Power over Ethernet (PoE) from a PoE injector or Mobile Gateway M NEO.
 - Space42 NEO Battery Pack.
- Rugged design with durable connectors.
- Easy to set up and operate.
- Easy satellite pointing using audio pointing aid.
- Stealth mode operation (when supported by the SIM).
- Prepared for fixed installations.
 - Supports VESA 50 Mounting.
 - Supports up to 100 m cable distance (PoE) between IP NEO M and connected equipment (e.g. indoor units).
- Over the Air software update: (via the RTM/Restful API's).¹
- PRISM Lite for use with the Space42 IP Handset in a PTT system.¹
- Full duplex, single or multi-user, standard data up to 1 Mbps².
- Support for streaming data (symmetric or asymmetric) at 16, 32, 64, 128, 256, 384, 512, 768 and 1024² kbps.
- Built-in DHCP/NAT wireless router.
- Built-in GNSS (supports GPS, GLONASS, Galileo and BeiDou navigation systems).
- IP68 protection.³
- Built-in web interface allowing you to manage your data sessions and customize the terminal to your specific needs, using a computer, tablet or smartphone.
- REST API for managing the terminal, getting status and configuring the terminal.
- Built-in SIP server managing voice communication¹
- Multilingual user interface (Arabic, Chinese, English, French, Japanese, Portuguese, Russian and Spanish).

1. Only applicable when connected to T4-NGS network.
 2. For T2/T3 network, the max speed is 444 kbps (max. Streaming rate 384 kbps).
 3. IP68 applies for the entire terminal when all covers and connectors are mounted correctly with the recommended caps and connector housings.

1.2.2 Interfaces

- 12-24 VDC power input.
- 3 x LAN (Ethernet) ports for IP connectivity, one standard LAN port, one LAN port with optional PoE in (PoE++ (PD) Type 3 class 6) to supply the IP NEO M with power (instead of using the DC input), and one LAN port with optional PoE out (PoE (PSE) Type 1 class 2) to supply a connected IP handset.
- 1 x USB 2.0 DRP type C port, max. 500 mA source current.
- Built-in WLAN.

1.3 Your IP NEO M terminal

1.3.1 IP NEO M overview

The IP NEO M is a compact unit comprising transceiver and antenna in one unit.

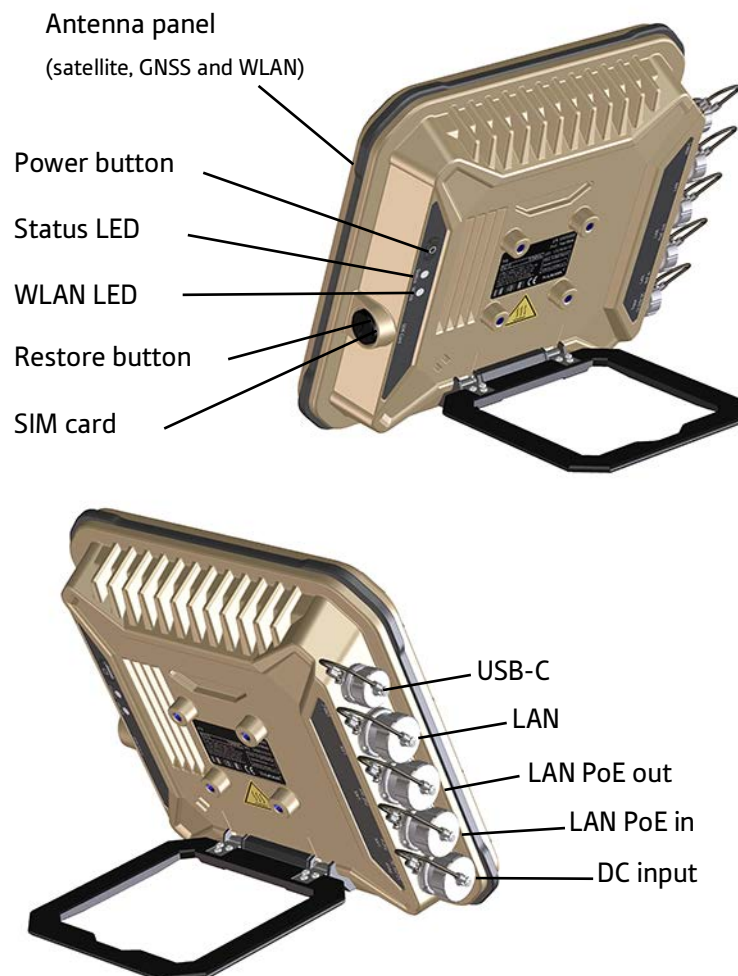

1.3.2 User interfaces

The **web interface** is a built-in web interface for easy configuration and daily use. The web interface is accessed from a computer, smartphone or tablet connected to the IP NEO M, using an Internet browser. No installation of software is needed. For further information on the web interface, see *The web interface* on page 3-2.

With **AT commands** you can configure and control the IP NEO M from a computer using an SSH session. For further details see *To access the terminal using AT commands* on page 2-15.

With the **REST API** you can use your own application to configure and get the state of the terminal. For details on the REST API, see the REST API documentation for the IP NEO M (doc. number 98-182365) attached to this PDF file.

Note | Not all browsers support attachments in PDF files. If you cannot see and open the attachment in your browser, use Firefox, or download and open this manual in a PDF reader such as Adobe Acrobat.

In addition to the above, you may have the following (only supported in T4-NGS network):

- **Thuraya PRISM PTT+ Portal**, used for configuration and management in a PTT system with Space42 IP Handset and the IP NEO M.
- **Remote Terminal Manager (RTM)**, used for remote configuration and management of several NEO terminals.

1.3.3 Antenna

The front part of the IP NEO M is the antenna part comprising:

- Satellite antenna.
- GNSS (Global Navigation Satellite System) antenna supporting GPS, GLONASS, Galileo and BeiDou.
- Wireless LAN (WLAN) antenna.

1.3.4 Battery

The IP NEO M comes with a built-in rechargeable battery. The battery is automatically recharged when power is applied to the IP NEO M DC input or PoE input. The Status indicator shows that the battery is charging. See *Light indicators (LED)* on page 4-10.

Time between recharging depends on the use. The web interface shows estimated time left for the battery. Recharge the battery regularly.

For battery specifications, see *Battery specifications (internal battery)* on page A-2.

1.3.5 SIM card

The IP NEO M requires a SIM to connect to the satellite network. Without a SIM you can still configure the terminal, but you cannot access the satellite network.

There are two options for the SIM:

- A physical SIM card: Nano SIM card (4FF) from your IP NEO M supplier
- An electronic SIM card: eSIM preinstalled in the terminal

Note | Before you can use the SIM, the SIM type (eSIM or USIM) must be selected in the web interface. See *To select the SIM mode* on page 3-29.

1.4 Part numbers

1.4.1 System part numbers

Item	Part number
IP NEO M satellite terminal (including AC/DC adapter and Ethernet cable)	408022A-42000

1.4.2 Options

The following options and accessories are available for the IP NEO M:

Item	Part number
Space42 IP Handset	408012A-42000
12/24 VDC cable, 3 m	408050A-009
AC/DC Adapter	408020A-950
Space42 Battery Pack (60 cm cable - terminal specific)	408016A-42000
Extension cable for battery (4m)	408016A-010
Pole mount	403650B-923
LAN Connection protector for outside installation	408020A-924

Operation

This chapter describes daily use and basic setup. For information on configuration with the web interface, see *Configuration* on page 3-1.

This chapter describes:

- *To get started*
- *To connect cables*
- *To switch the IP NEO M on or off*
- *To connect using WLAN*
- *To access the web interface*
- *To access the external network*
- *Data connection*
- *To make phone calls over satellite (only with T4-NGS)*
- *Push-To-Talk (PTT) (only with T4-NGS)*
- *Stealth mode*
- *Alerts*
- *Status of the IP NEO M*

2.1 To get started

2.1.1 To unpack and assemble the IP NEO M

Initial inspection

Inspect the shipping carton immediately upon receipt for evidence of damage during transport. If the shipping carton is severely damaged or water stained, request that the carrier's agent be present when opening the carton. Save the carton packing material for future use.



WARNING! To avoid electric shock, do not apply power to the system if there is any sign of shipping damage to any part of the front or rear panel or the outer cover. Read the safety summary at the front of this manual before installing or operating the system.

After unpacking the system, inspect it thoroughly for hidden damage and loose components or fittings. If the contents are incomplete, if there is mechanical damage or defect, or if the system does not work properly, notify your dealer.

What's in the delivery package

The following items are included in the delivery package:

- IP NEO M terminal
- AC/DC adapter (standard adapter, not outdoor protected)¹
- Ethernet cable (standard cable, IP20 - not outdoor protected)¹
- Getting started booklet
- Production certificate

Note You need a SIM from your provider to access the satellite network. This can be a physical SIM card or the eSIM embedded in the terminal.

You also need a **power cable**, depending on the type of power supply you are using. See *External power* on page 2-4.

To insert the SIM card

Note This section only applies if you have a physical SIM card.

The IP NEO M uses a **Nano type** SIM card. The location of the SIM slot is indicated in the picture to the right.

Note Switch off the terminal before replacing the SIM card.

1. Unscrew the SIM cover using a large flat-bladed screwdriver.
2. Insert the Nano SIM card in the SIM slot with the chip side facing left as shown.
3. Put the SIM cover back on and tighten it with the screwdriver.

This is important in order to maintain the Ingress Protection of the IP NEO M.



To remove the SIM card

Note When the SIM card is removed you cannot make calls or data sessions on the satellite network, but you can use the built-in web interface to set up the terminal.

To remove the SIM card:

1. Unscrew the SIM cover.
2. Use tweezers to grab the SIM card and pull it out.
3. Close the cover and tighten it.



1. Contact your supplier for cables and other accessories suitable for outdoor use.

2.1.2 Fixed installation

The IP NEO M is a portable terminal, but may also be used in fixed installations. For this purpose, it has four M6 threaded holes compatible with VESA 50 mounting devices.

A dedicated pole mount kit is available from your supplier.

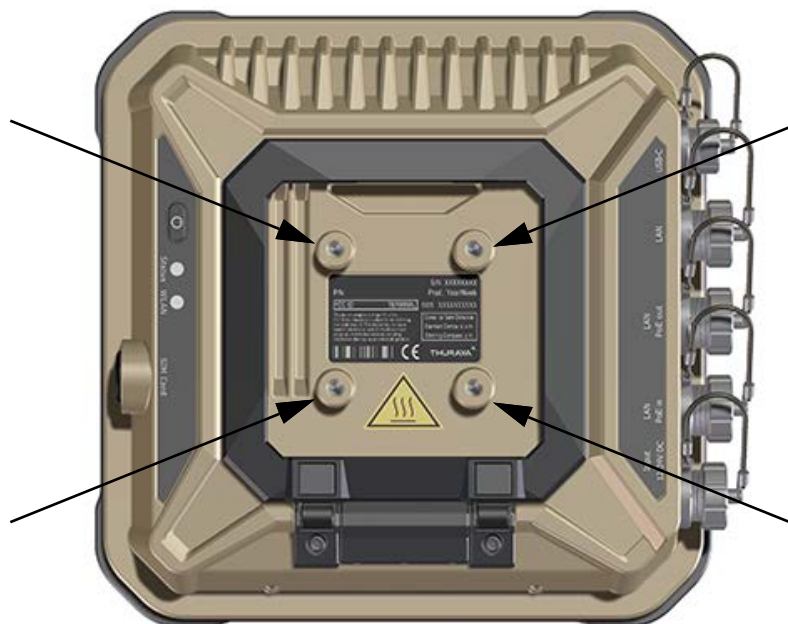

1. Mount your VESA 50 mounting bracket on the IP NEO M using M6 bolts.



CAUTION! The bolts or thumb screws must penetrate **less than 9 mm** into the threaded holes in the IP NEO M.

2. Place the IP NEO M with mounting bracket temporarily on a pole or other mounting place, pointing the front of the antenna in the approximate direction of the satellite.
3. Start up the IP NEO M and point the antenna as described in *To point the antenna to the satellite* on page 2-9.
4. When you have accepted the signal strength, fasten the IP NEO M in the pointed position.

Note

Once the IP NEO M is pointed, you can set it up to automatically register on the satellite network at power-up. This way you can avoid going through the pointing procedure every time you start up. See *Pointing at start-up* on page 3-21.

Important

Mount the protective caps on all connectors that are not in use.

2.2 To connect cables

- Important** When you use the terminal outdoors, mount the protective covers on all unused connectors to maintain the ingress protection (IP grade).
Also, for all connectors used, use cables that have protective circular connector housing with 13/16" UNS Thread, in order to maintain the IP grade.

2.2.1 External power

The IP NEO M comes with a built-in rechargeable battery. The battery is automatically recharged when external power is applied to the IP NEO M.

There are two interfaces for providing external power:

- DC input.
- Power over Ethernet (PoE).

DC input

- Note** Depending on your power source you must acquire a **suitable cable for connection to your power source**. This includes the power cable to connect the AC/DC adapter to Mains. Contact your supplier for available options.

Refer to *DC power input* on page A-3 for specifications and pin-out for the DC Power input.

To power the terminal or to charge the battery, connect one of the following external power sources to the DC input:

- An AC/DC adapter connected to 100-240 V Mains.

- Important** The included AC/DC adapter is certified for use with the IP NEO M. Use of another power supply may not support the guaranteed altitude, operation temperature or efficiency of the IP NEO M.

- Important** The included AC/DC adapter is for indoor use and is not water-protected.

- An external battery (min 120 Wh).¹
- 12-24 VDC power supply (max. range 10.8-33.6 VDC).

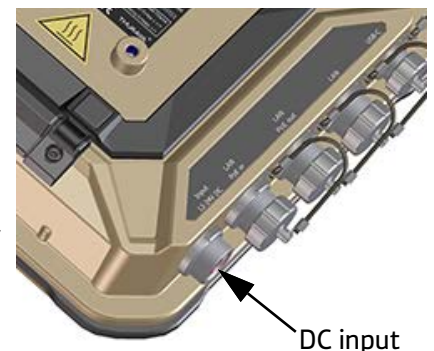

1. If you are using an external battery, the internal battery should preferably be fully charged when you connect the external battery.

Power over Ethernet

Instead of using the DC input, you can supply power to the IP NEO M through the RJ-45 connector marked **LAN PoE in**.

Note A PoE supplying device used with the IP NEO M must comply with minimum **Type 3 Class 6 (IEEE802.3bt)**, capable of supplying minimum 50 VDC 600 mA/ pair (in total 60 W).

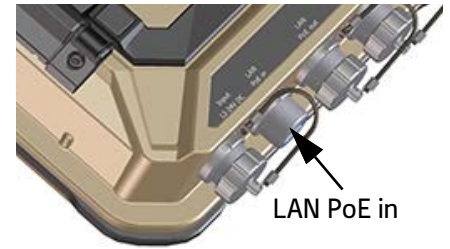

To ensure full speed and PoE performance, use a min. Cat. 5E or Cat. 6A, max. 100 m, LAN cable to connect the **LAN PoE in** input to a PoE supplying device (min. PoE Type 3 Class 6).

Important The included Ethernet cable is **IP20**, i.e. it does **not provide any protection against dust and water ingress**. To obtain dust and water ingress protection for outdoor use, the cable must be used together with a field installable **protective connector housing (IP67, P/N 408020A-924)**, or you must acquire a new IP67 protected cable with circular connector housing. Contact your supplier for details.

2.2.2 LAN

The IP NEO M has three LAN connectors, one standard LAN port, one with PoE out (e.g. for a handset) and one with PoE in (used for powering the IP NEO M).

To connect an IP handset (only for T4-NGS network)

The IP NEO M has a LAN interface with PoE, so you can power your handset using the LAN interface. Note that for PoE out to work, it must be enabled in the terminal web interface

Note Make sure your IP handset complies with PoE class 2 (7 W)

For details on **initial setup** of your IP handset and the IP NEO M, see

- The documentation for your handset
- *First time SIP setup* on page 2-17
- *Voice setup* on page 3-18

To connect a wired IP handset:

1. Start up the IP NEO M terminal.
2. Connect the IP handset to the **LAN PoE Out** connector on the IP NEO M.

When the IP handset is powered and ready, you should be able to make and receive calls over satellite.

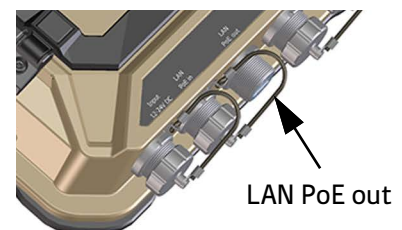

To connect a PC

Note For the connection to work without any further setup, the PC must be set up as a DHCP client, that is IP assignment and DNS server assignment must be set to **Automatic (DHCP)** in your PC.

1. Connect a LAN cable (min Cat 5E or Cat 6A, max 100 m) between your computer and one of the RJ-45 connectors, marked **LAN**, **LAN PoE in** or **LAN PoE out**.

Your computer is now connected to the IP NEO M and you can access the web interface as described in *To access the web interface* on page 2-8.

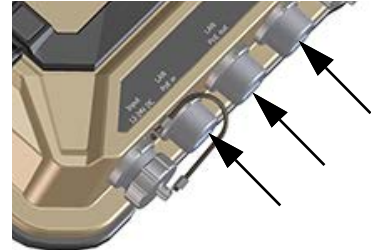

Important The included Ethernet cable is **IP20**, i.e. it does **not provide any protection against dust and water ingress**. To obtain dust and water ingress protection for outdoor use, the cable must be used together with a field installable protective connector housing (IP67), or you must acquire a new IP67 protected cable with circular connector housing. Contact your supplier for details.

2.2.3 USB

There is one USB connector on the IP NEO M, marked USB-C.

The USB-C connector (USB 2.0 DRP) can be used for:

- Additional LAN port: Connect an USB-to-Ethernet adapter to obtain an additional LAN port.
- AT commands: Connect a laptop to the IP NEO M and use AT commands for communication with the IP NEO M.
For syntax and available AT commands, see *Command reference* on page B-1.

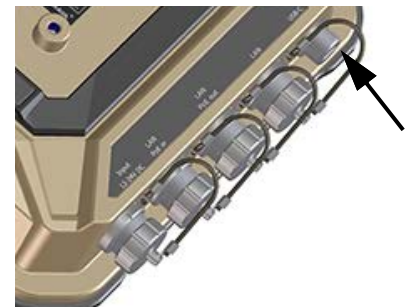

2.3 To switch the IP NEO M on or off

1. Push and hold the power button until the **Status** indicator blinks rapidly green. This may take some seconds.
2. When the **Status** indicator blinks slowly or is constant green, the terminal is ready for use.

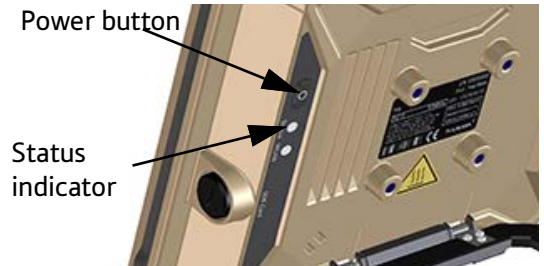

Note At this point you may hear a sound from the IP NEO M, indicating that it is ready to be pointed towards the satellite (see *To access the external network* on page 2-9). If you do not want to point the antenna now, just push the power button briefly to accept the current signal strength.

3. To switch off, hold the power button until the **Status** indicator blinks yellow. This may take some seconds.

To recharge the battery, connect external power. See *External power* on page 2-4.

Note To save power when the terminal is running on battery, you can use the **Inactivity power save** mode. For details, see *Power control* on page 3-28.

2.4 To connect using WLAN

Note The WLAN interface is **disabled** by default. To enable the WLAN interface, first connect to the LAN interface, then access the web interface and enable WLAN as described in *WLAN interface setup* on page 3-16.

1. Check that the WLAN LED is on (green or yellow), meaning that WLAN is ready in your IP NEO M.
2. Place your WLAN-enabled device (computer, tablet or smartphone) close to the IP NEO M, but **not** in front of the satellite antenna.
3. On your device, search for available WLAN networks.
4. Select the IP NEO M WLAN access point when it appears in your list of available wireless networks. The default name (SSID) is the product name followed by the last four digits in the serial number (<name>-<last 4 digits of serial number>).

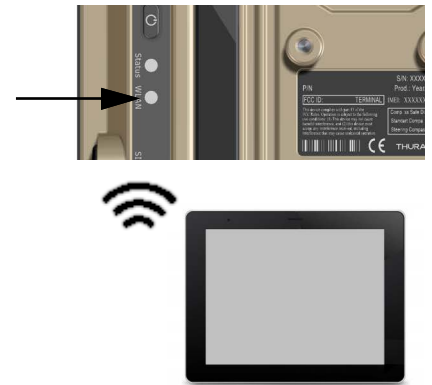

Note You may have to enter a password. By default the password is the **serial number**¹ of your IP NEO M and the encoding type is **WPA2-AES**.

1. You find the serial number on the label on the IP NEO M

Your device is now connected to the IP NEO M. In the web interface, the WLAN icon shows the number of devices connected to the IP NEO M via WLAN. Example: 

Note You can have maximum 8 clients connected to the WLAN.

For information on how to configure the WLAN interface in the IP NEO M, see *WLAN interface setup* on page 3-16.

2.5 To access the web interface

You can use the built-in web interface for configuration and operation of the IP NEO M. To access the web interface:

1. Start up the terminal.
For details, see *To switch the IP NEO M on or off* on page 2-7.
2. Connect your computer or smartphone to the terminal, using LAN or WLAN as described in the previous sections.
3. Open your browser and enter the IP address of the terminal in the address bar. The default IP address of the terminal is **192.168.0.1**.
4. When prompted, enter user ID and password. Default values are:
 - Standard user:
User ID: **user**¹
Password: <empty>
 - Administrator user
User ID: **administrator**
Password: <serial number of your IP NEO M>

After logging in with the default administrator password you are prompted to change the password.

For more information on the web interface, see *The web interface* on page 3-2.

1. If you are logged in as “user”, you cannot make changes to the configuration. For details on user rights, see *Access levels for the web interface* on page 3-2.

2.6 To access the external network

2.6.1 To point the antenna to the satellite

Note You can choose to cancel pointing from the pointing page in the web interface. In this case you cannot communicate on the satellite network, but you can access all terminal settings.

Before pointing

Before pointing the antenna you can use the coverage map below to find your approximate location in relation to the satellites. The IP NEO M supports T2, T3 and T4-NGS satellites.

- T2 is located at 44 degrees East longitude.
- T3 is located at 98.5 degrees East longitude.
- T4-NGS is located at 44 degrees East longitude, service launch in fall 2025.

Note If the IP NEO M is sold and used in the US, satellite functionality is not available.



■ SERVICE AVAILABLE - Thuraya-4
■ SERVICE POSSIBLE - Thuraya-4

To repoint the antenna

You may need to point the antenna again later, e.g. if the terminal has been moved or the signal is blocked.

To start the pointing process again:

1. From the web interface, select  (Control panel) > **Point now**.
2. Go through the pointing process as described in the previous section *To point the antenna*.

2.6.2 Registration procedure for the satellite network

If you have connected a computer and accessed the web interface, you can see the progress in the status field.

- **Initializing:**
The terminal is starting up.
- **Acquiring position:**
The terminal is trying to get a position fix from the GNSS satellites. A position is needed before the terminal can be pointed.
- **Pointing:**
The terminal is in pointing mode and the user needs to point the terminal and accept the current pointing.
- **Channel search:**
The IP NEO M is searching for the best channel to use for registration.
- **Registering:**
The IP NEO M is registering itself on the network.
If the position has not yet been acquired at this point, the status field may show **Acquiring position**.
- **Ready (or other status information):**
Ready means the IP NEO M is registered on the network and is ready to set up data connections. If there is any other status information to show, e.g. if there is a warning, the status field will show that instead.

Note

To enable data/Internet connectivity you must first activate a data connection. See *To start and stop data connections* on page 2-12.

Do you need a PIN?

Note

You may need a SIM PIN for your terminal to access the network. If you are asked for a PIN and you select **Cancel**, you cannot communicate on the network, but you can access all settings.

To be able to enter a SIM PIN you must access the built-in web interface. For details, see *To enter the SIM PIN in the web interface* on page 3-7.

2.7 Data connection

2.7.1 Router function

The terminal has a router function which routes traffic between the local network connected to the terminal and the satellite network connection.

The router contains NAT (Network Address Translation) which allows sharing of a public IP address between a number of local network users.

2.7.2 Standard or Streaming data

The satellite network supports different classes of data connection to the Internet. The main classes are **Standard data** and **Streaming data**.

- Using a **Standard data** connection, several users can share the data connection simultaneously. This type of connection is ideal for TCP/IP traffic such as e-mail, file transfer, and Internet and intranet access.
The user pays for the amount of data sent and received.
- Using a **Streaming data** connection, you get an exclusive, high-priority connection, ensuring seamless transfer of data. This type of connection is ideal for time critical applications like live video over IP.
The user pays for the duration of the connection (per minute charge).

You can set up the connection types in the web interface. For details, see *To control data connections from web interface* on page 3-8.

2.7.3 To start and stop data connections

By default, you must manually activate your data connection before you can access the external network. However, you can enable automatic activation of a data connection. See *Enable Automatic Connection Activation* on page 3-10.

Note | You can only have one active data connection at a time on the external network.

To start and stop data connections on your IP NEO M:

1. On the connected device, open your browser and type the IP address of the terminal (default IP address: **192.168.0.1**) in the address bar to access the web interface.
2. Click  on the connection you want to start. For details, see *To control data connections from web interface* on page 3-8.

2.7.4 PPPoE (Point-to-Point Protocol over Ethernet)

Overview

You can establish a PPPoE connection to the satellite network using the IP NEO M system. Use PPPoE if you want to control your connection independently of the web interface.

Possible applications are:

- Connecting a router
- Connecting broadcast equipment, optionally through a PC
- Establishing a Pico cell for the use of cell phones

The following drawing shows connections managed through PPPoE and web interface respectively.

Note With T4-NGS network, up to 8 Standard data connections or 3 Streaming connections at a time can be active.
(only 1 connection with T2/T3)

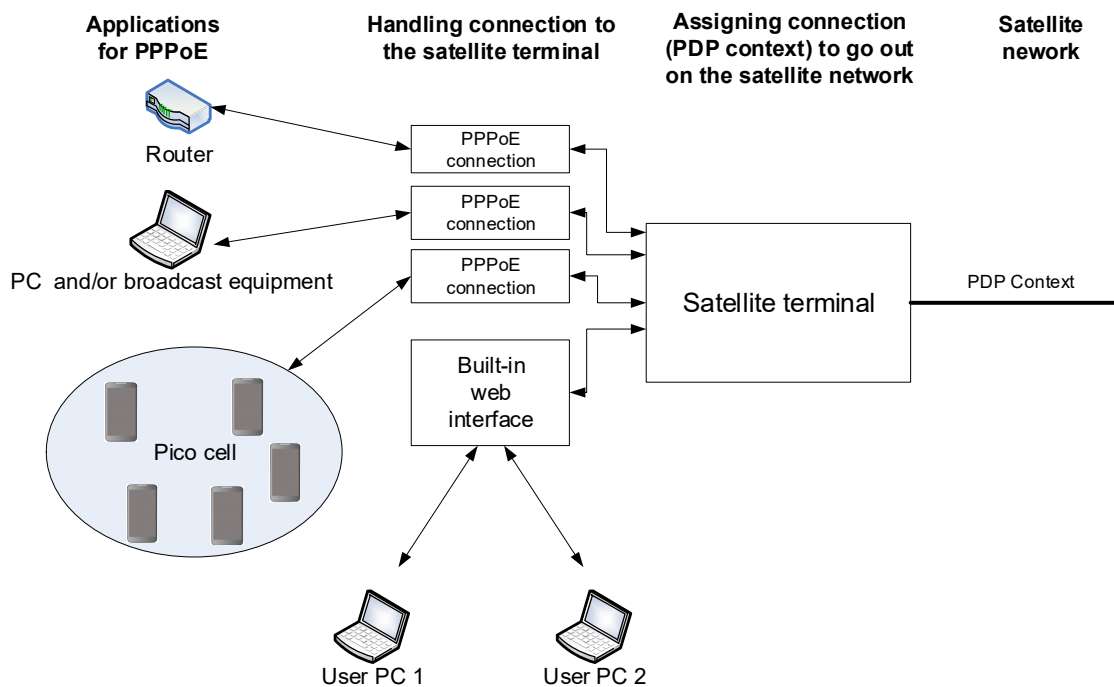

To configure the connected equipment for PPPoE

How to configure your equipment depends on the type of equipment. Refer to the user documentation of the equipment. As a minimum, you need to configure the following parameters in your equipment in order to make PPPoE work with the terminal:

- User name and password.

The user name and password can be left blank (or insert user name: void and password: void). Then the registration on the Access Point is most commonly done in such a way that the data connection is established with a dynamic IP address from the airtime provider.

To request a static IP (if subscribed to) from the Access Point you must type in the user name and password from your airtime subscription.

Note for MAC OS: User name and password are required. Use user name void and password void. This works for some ISPs. Contact your airtime provider for further information.

- For setups that have a check box for “Enable LCP extensions”, deselect this.

No further configuration is needed to make a Standard IP data connection to the Internet.

See the table below for information on how to configure specific services for your PPPoE connection.

If you need a certain service, for example a Streaming class, you must type in a specified text string when asked for a service name. The following table shows the service names supported by the terminal.

Text to type in the Service Name field	Function
XBB:BACKGROUND	Initiates a Primary Standard Data connection (same as blank)
XBB:STREAM16K	Initiates a Primary Streaming 16 kbps connection
XBB:STREAM32K	Initiates a Primary Streaming 32 kbps connection
XBB:STREAM64K	Initiates a Primary Streaming 64 kbps connection
XBB:STREAM128K	Initiates a Primary Streaming 128 kbps connection
XBB:STREAM256K	Initiates a Primary Streaming 256 kbps connection
XBB:STREAM384K	Initiates a Primary Streaming 384 kbps connection
XBB:STREAM512K ¹	Initiates a Primary Streaming 512 kbps connection
XBB:STREAM768K ¹	Initiates a Primary Streaming 768 kbps connection
XBB:STREAM1024K ¹	Initiates a Primary Streaming 1024 kbps connection

1. Only in T4-NGS network.

2.7.5 To access the terminal using AT commands

1. Make sure that AT shell is enabled and the AT shell password is set up in the web interface, see *To set up AT shell* on page 3-31.
2. Connect your computer to the IP NEO M terminal.
3. On the connected computer, start an SSH connection using the local IP address of the IP NEO M (default is 192.168.0.1). Use "atshell" as user.

Example: `ssh atshell@192.168.0.1`

4. When prompted, enter the AT shell password you defined in the web interface (step 1).
5. When the connection is established, type in your AT commands.

For information on supported AT commands, see *Command reference* on page B-1.

2.8 To make phone calls over satellite (only with T4-NGS)

2.8.1 To connect a phone

Your smartphone or IP handset can be set up to make and receive calls over the satellite network, using the terminal's phone number.

Note Make sure your phone has an integrated SIP client that allows registration with the terminal's SIP server. You can use a dedicated SIP phone or install a suitable SIP client application on your computer or smartphone. To register with the terminal, your phone/application must support voice codec G.711.

You can register up to 4 phones (SIP clients) with the IP NEO M terminal, but only one call at a time can be active in the satellite network. However, you can still make local calls between phones connected to the same IP NEO M terminal while an external call is ongoing.

To connect your smartphone for making calls

To use your phone to make calls through the IP NEO M using WLAN, do as follows:

1. Start up the IP NEO M terminal.
2. Connect your smartphone to the wireless access point of the IP NEO M.
3. See *To connect using WLAN* on page 2-7.
4. Start a SIP application.

Once registered, you should now be ready to make and receive calls over satellite. For details on initial setup of your smartphone and the IP NEO M, see:

- The documentation for your handset
- *First time SIP setup* on page 2-17
- *Voice setup* on page 3-18



To connect a wired IP handset for making calls

The IP NEO M has a LAN interface with PoE, so you can power your handset using the LAN interface.

Note Make sure your IP handset complies with PoE class 2 (7 W)

Note If you are using a Space42 IP Handset, no initial configuration is necessary.

For details on initial setup of your IP handset and the IP NEO M, see

- The documentation for your handset
- *First time SIP setup* below
- *Voice setup* on page 3-18

To connect a wired IP handset, do as follows:

1. Start up the IP NEO M terminal.
2. Connect the IP handset to the **LAN PoE Out** connector on the IP NEO M.

When the IP handset is powered and registered, you should now be able to make and receive calls over satellite.

First time SIP setup

If it is the first time you connect your phone to the IP NEO M for making calls, you must first set up the SIP server details in your phone. For information how, see the user documentation for your phone and for the SIP application. You may be asked to enter some of the following details:

- SIP server address and port: Default address: 192.168.0.1, Port: 5060
- User name: Local number in IP NEO M (0501 to 0504)
- Password: Create a four-digit password for the IP handset.
- Codec priority: Highest priority codec type: Must be G.711.

Note

The user name and password must match the IP handset settings in the IP NEO M. See *Voice setup* on page 3-18.

2.8.2 To make or receive a phone call with IP NEO M

To make a call from the IP NEO M

- To make a call, dial
+<country code> <phone number> followed by off-hook key.

Example: To call Cobham Satcom in Denmark (+45 39558800), dial + **45 39558800**

You can dial **00** instead of + in front of the country code.

If there was an error establishing the connection, the web interface of the IP NEO M shows an error message.

To receive a call

By default, all phones connected to the IP NEO M will ring when the mobile number of the IP NEO M is called.

Information on missed calls is stored in the call log. You can see the call log in the web interface (**Control panel**  > **Logs** > **Call log**).

To make a call to the IP NEO M

To make a call to a phone connected to the IP NEO M, dial + <**Mobile number**>

- + is the prefix used in front of the country code for international calls. This is **00** when calling from countries in Europe and from many other countries.
- **Mobile number.** For information on the mobile number, refer to your airtime subscription.

2.8.3 Local numbers and special functions

Overview

There are a number of local numbers and dialing functions available in the IP NEO M.

The following list shows the allocated local numbers and special-purpose numbers for the IP NEO M.

Number	Function
0 followed by one of the numbers 501-504 and off-hook key	Local call to one smartphone or IP handset connected to the same IP NEO M terminal.
0500 followed by off-hook key	Local call broadcast to all locally connected phones.

Apart from the numbers above, the IP NEO M uses the following dialing prefixes:

- #31# before the phone number will hide the callers phone number to the recipient.
- *31# before the phone number will show the callers phone number to the recipient where it would otherwise be hidden, e.g. because the number is an ex-directory number.

2.8.4 To use a Space42 IP Handset with the IP NEO M

In addition to making calls over the T4-NGS network, the Space42 IP Handset offers some functions for use with the IP NEO M terminal.

Note If you want to use the IP NEO M functions of the Space42 IP Handset you must log in using the same user or administrator account used for the web interface.

If you have a Space42 IP Handset connected to the terminal and you are logged into the IP NEO M, you can use the handset to:

- Make calls over the Thuraya T4-NGS network.
- Enter PIN/PUK for the terminal.
- View alarms and event log.
- View current satellite status and signal strength
- Start and stop data connections over satellite.
- Set up PTT function and use as PTT handset with IP NEO M.

For details on how to set up IP handsets connected to the IP NEO M, see *Voice setup* on page 3-18.

For details on the Space42 IP Handset, see the user manual for the Space42 IP Handset (doc. no. 98-187031).

2.9 Push-To-Talk (PTT) (only with T4-NGS)

When used with the Space42 IP Handset in PTT mode, the IP NEO M has built-in PRISM functionality (PRISM Lite), controlled by the PRISM PTT+ Portal.

This enables you to use a Space42 IP Handset with the IP NEO M in a PTT system, without the need for a Mobile Gateway.

Note The PRISM PTT+ server is located in the Thuraya network. Cloud based PTT servers are **not** supported.

Note that you must have a PTT service subscription for the IP NEO M, and the PRISM Lite feature must be enabled in the web interface before you can use it (Control Panel > Advanced > PRISM Lite).

2.9.1 PRISM Lite

PRISM Lite is a light version of PRISM (Private Routing and Intelligent System Management) that acts as a PTT client and supports inter-agency talk-groups and secure AES256 encrypted voice communication. The only supported local interface is LAN (with PoE), to which you can connect a Space42 IP Handset.

When the IP NEO M is used in a PTT system, PRISM Lite routes all traffic to and from the IP NEO M through an AES-256 encrypted multi-path tunnel between the terminal and a server, using satellite connectivity. Depending on server routing, the Space42 IP Handset attached to the IP NEO M will have direct access to services on the server and beyond.

To be able to use PRISM Lite with your terminal, you must first have a subscription for the service from your provider.

All PRISM Lite configuration is done in the PRISM PTT+ Portal, except enabling PRISM Lite in the IP NEO M, which is handled in the IP NEO M web interface (see *To enable/disable PRISM Lite in the terminal (only with T4-NGS)* on page 3-31).

2.10 Stealth mode

If Stealth mode is supported by the SIM, you can put the IP NEO M in Stealth mode. When the IP NEO M is in Stealth mode, **WLAN, LEDs and system sounds are disabled**.

Important Note that this setting **only applies to the IP NEO M** terminal. Connected equipment must be put into Stealth mode individually.

To activate Stealth mode in the terminal:

1. Connect a computer and access the web interface at <http://192.168.0.1> as described in *To access the web interface* on page 2-8.
2. Select  (Control panel).
3. Click the **Stealthmode** tile, click **Enable Stealthmode** and click **Apply**.
When Stealth is activated, the tile image is red, and a red Stealth icon appears in the status bar at the top of the page.
4. To exit Stealth mode, click the **Stealthmode** tile again, remove the checkmark and click **Apply**. The text and image on the tile becomes gray and the Stealth icon disappears from the status line at the top.



2.11 Alerts

When an alert is registered, the web interface show a warning icon  in the icon bar as long as the alert is active. The **Alerts** list only shows alerts that are currently active.

To view the Alerts list, click  from the icon bar at the top of the page, or select **Alerts** from the **Support** page.

For more information on the alert messages, refer to *List of alert messages* on page 4-12.

2.12 Status of the IP NEO M

Web interface: If the screen for the web interface is large enough, it shows a status field at the bottom of the page or in the right side of the page. If not, click  to show the status page. Click  again to return to the previous page.

The Status page shows information such as terminal status, network status, position status and ongoing communication.

Configuration

This chapter describes how to use the **web interface** to operate, set up and configure your system.

The Configuration chapter has the following sections:

- *The web interface*
- *To point the antenna*
- *To enter the SIM PIN in the web interface*
- *To control data connections from web interface*
- *Status information*
- *The Control panel*
- *To select the satellite network*
- *To activate Stealth mode*
- *To use the logs*
- *Battery status information*
- *To set up the interfaces*
- *Voice setup*
- *Support features*
- *Terminal settings*
- *Advanced LAN*
- *Advanced settings*

3.1 The web interface

3.1.1 What is the web interface?

The web interface is built into the terminal and is used for operating, setting up and configuring the system.

You can access the web interface from a computer with a standard browser.

3.1.2 Access levels for the web interface

There are two levels of access to the web interface:

user has access to the following:

- Start and stop data connections
- Read main configuration parameters.
- Generate and download diagnostics report.
- Embedded user manual.
- Start and stop pointing if manual pointing is required.

administrator has access to the same as **user**, plus the following:

- Read and write all main configuration parameters.
- Upload software.
- Change password for “user” and “administrator”.
- Enable AT shell access and change password for AT shell.

3.1.3 To access and navigate the web interface

To access the web interface

To access the web interface:

1. Start up the terminal.
For details see *To switch the IP NEO M on or off* on page 2-7.
2. Connect your computer to the terminal.
For details see *LAN* on page 2-5 or *To connect using WLAN* on page 2-7.
3. Open your browser and enter the IP address of the terminal in the address bar.
The default IP address of the terminal is **192.168.0.1**.
4. When prompted, enter user ID and password. Default values are:
 - Standard user:
user ID: **user**
Password: <empty>
 - administrator user
User ID: **administrator**
Password: <serial number of your IP NEO M>

Note

You are prompted to change the administrator password after first logon. For details, see *To change the administrator password* on page 3-27.

To change the language

When you have access to the web interface, if you want to display a different language than English:

1. Select the Control panel  in the bottom right corner.
2. Select **Terminal settings**.
3. At **Language**, select a language from the drop-down list and click **Apply**.

You can change the language to **Arabic, Chinese, French, Japanese, Portuguese, Russian** or **Spanish**.

Overview of the web interface

When the web interface opens, the title bar shows the name of the product. The example below shows the **Control panel** page.















The web interface consists of the following sections.

- **Name** of current page. Tap or click to refresh the page.
- **Icon bars** at the top and bottom are present on all pages and hold icons that give access to status such as battery level and signal level as well as active alerts when relevant. It also holds the icon for the Control panel. For explanations of the icons, see the next section, *Icons in the icon bars*.
- **Contents section** shows the contents of the selected page. This section is used for viewing or changing settings, or for performing actions. On the opening page, this section is used to start and stop data connections.

- **Status and position section** shows the status of the terminal and the network connection, position information, ongoing calls and data sessions etc. The Status section is not shown on small screens. If the screen is small (e.g. on a smartphone), you can show/hide the status by clicking  at the bottom of the page.

Icons in the icon bars

The icon bars are always available at the top and bottom of the web interface. Some of the icons are permanent while others are temporary.

Icon	Explanation
	Power status. The icon changes according to status. Click to see detailed battery status.
	Battery level
	Battery charging
	Signal level of the external network (satellite network).
	WLAN interface. Bright when WLAN is enabled, grayed when it is disabled. Click to access WLAN settings.
	The WLAN icon shows the number of connected devices.
	An alert is active. Click the icon to see a list of active alerts. Note that this icon will remain in the icon bar as long as the alert is still active.
	Help. Click to get context-sensitive help for the current page (in this manual).
	Control panel. Click to access the settings.
	Startup page where you can start and stop data connections. Click to go to the startup page.
	The "1" at the icon shows that a satellite data connection is running.
	Status. If the screen is not large enough to show the status field, this icon appears at the bottom of the page. Click the icon to see status of the terminal and satellite connection. Click again to exit the status page.

To navigate the web interface

- **To access status and settings**, tap or click the relevant icon in the icon bar or select  to access the **Control panel**. The status or settings are displayed in the contents section.
- **To see your current location and to move back through the Control Panel menu**, use the breadcrumbs just below the icon bar.
- **To scroll through longer pages**, use the scroll bar or swipe.
- **To refresh the current page**, press Ctrl+F5 (PC) or Apple+R (Apple) or Cmd+R (Apple).

3.1.4 Menu tree for the web interface

The drawing below shows the menu structure of the IP NEO M web interface.

Note | The green colored items are only available with T4-NGS.

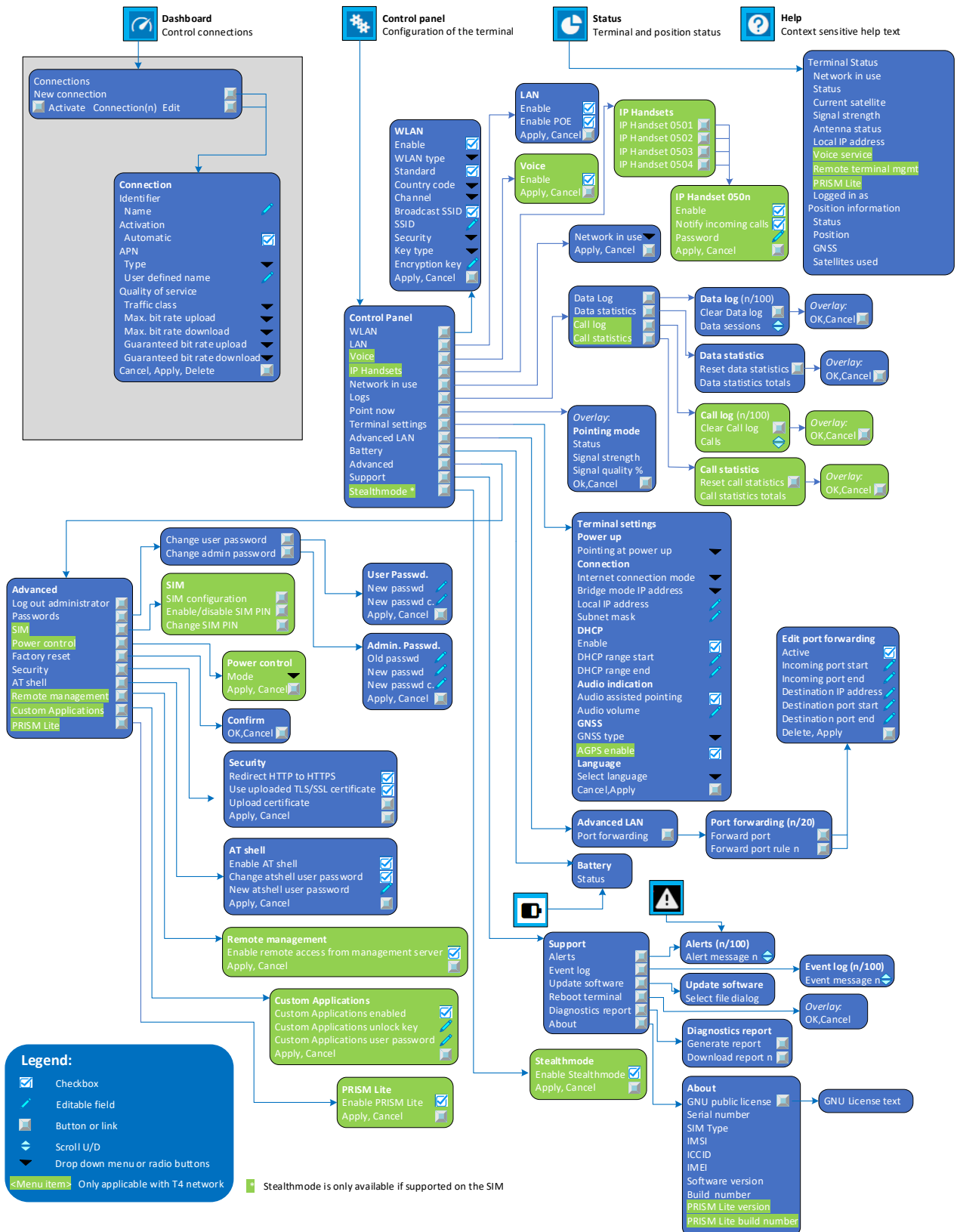

3.2 To point the antenna

Before you can use the satellite network, you must point the antenna in the direction of the satellite and find the best possible signal strength. For detailed information on the pointing procedure, see *To point the antenna to the satellite* on page 2-9.

You can use the web interface to help you with the pointing process.

3.2.1 Pointing in web interface

To start the pointing process from the web interface:

1. If the pointing process is not automatically started, select  (Control panel) and then **Point now**.
The signal strength is shown on the screen.
2. Turn and tilt the antenna slowly until you have obtained the highest possible signal strength, as described in *To point the antenna* on page 2-10.
3. Click **OK**.

The terminal will now try to register on the satellite network.

3.3 To enter the SIM PIN in the web interface

Note You need a SIM to access the network. The SIM can be a physical SIM card inserted in the terminal or an eSIM which is embedded in the terminal.

3.3.1 Do you need a SIM PIN?

Note You may not have to enter a SIM PIN to access the terminal. This depends on whether or not the use of a SIM PIN is enabled on your SIM card.
The administrator can enable and disable the use of a SIM PIN. For details, see *To enable or disable the use of a SIM PIN* on page 3-29.

If a smartphone or computer is connected when you start up the terminal, you can access the web interface and enter the SIM PIN there.

3.3.2 To enter the SIM PIN

If your SIM card requires a PIN and the PIN has not yet been entered, you must enter it before you can make calls or access the external network. Until you have entered the PIN you cannot access the network, but you can still configure your terminal.

To enter the PIN, do as follows:

1. Access the web interface.
If the terminal needs a PIN, a popup window tells you to enter PIN.
2. Type in your PIN and click **OK**.

When pointing is completed and the correct PIN is entered, you are ready to make calls or data sessions.

3.3.3 To cancel the SIM PIN

If you select **Cancel** when you are asked for a PIN, you can use the web interface as normal, but you will not be able to access the network to make calls or data sessions.

To enter the PIN later, after canceling the first time, do as follows:

1. From the icon bar at the top, click .
The **Alerts** list opens.
2. Click **Resolve** next to **Enter PIN**.
3. Type in your PIN and click **OK**.

3.4 To control data connections from web interface



The main page of the web interface is used to start and stop data connections and to set up the data connections.

3.4.1 To start and stop data connections

Note By default, if you want to use a data connection, you must manually start it from the web interface. However, you can set up the IP NEO M to automatically establish a data connection when you connect equipment to the LAN or WLAN interface. See *Enable Automatic Connection Activation* on page 3-10.



To start and stop data connections on your IP NEO M:

1. In the opening page, locate the connection you want to start.

Note The icons for starting  and stopping  connections are only active if the terminal is ready and registered on the satellite network. Otherwise you cannot start data connections.

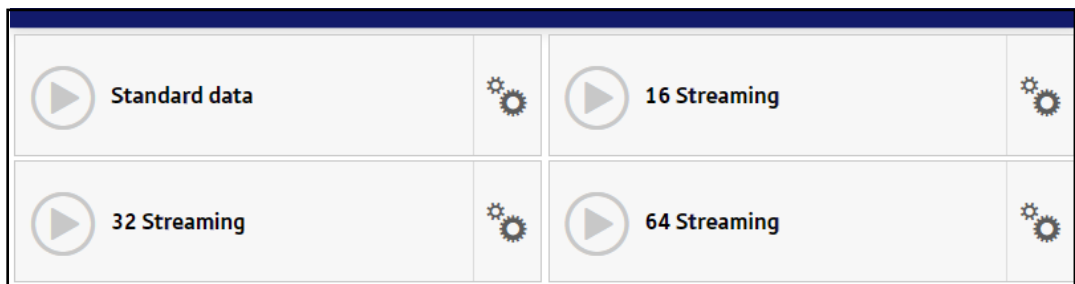
If a connection is automatically activated (has Automatic Activation enabled), the icons for starting and stopping are replaced by a lock symbol .



2. Click  to start the connection. The connections icon at the bottom of the page shows  when a satellite data connection is running.

Note With T4-NGS network, up to 8 Standard data connections or 3 Streaming connections at a time can be active. (only 1 connection with T2/T3)

3. Click  to stop the connection.

If the connection fails, the connection tile shows an exclamation mark  and an error message. The error message is also shown in the data log, see *Data log* on page 3-14.

When a connection is active, the icon changes to  and the tile for the active connection shows:

- IP address: The IP address that has been assigned by the service provider to this session.
- Transferred data: For Standard data, the tile shows the total amount of transmitted and received data since the connection was established.
- Connection duration: The tile shows the total time the connection has been active.
- Bit rate: For Streaming connections, the tile shows the fixed bit rate.

3.4.2 To change a connection

Available default connections

By default, the following connections are available:



Name	Type of connection
<p>Standard data</p>	<p>Several users can share the data connection. This type of connection is ideal for TCP/IP traffic such as e-mail, file transfer, and Internet/intranet access.</p> <p>The user pays for the amount of data sent and received.</p>
<p>Streaming data</p> <p>The following default Streaming classes are available:</p> <p>16, 32, 64, 128, 256, 384, 512, 768, and 1024¹ kbps Streaming (symmetric)</p>	<p>An exclusive, high-priority connection, ensuring seamless transfer of data. This type of connection is ideal for time critical applications like live video over IP. The user pays for the duration of the connection.</p>

1. For T2/T3 network, the max Streaming rate is 384 kbps.

You can use these connections as they are, or build your own connections as described in the next section.

To customize connections

You access the connections from the Dashboard.

1. To access the Dashboard click  at the bottom of the page.
2. To change a connection, click  in the right side of the tile with the connection.





You must be logged in as administrator in order to change, delete or create connections.

You have the following options to change a connection:

If you want to	Do the following
Change the name of the connection	Under Identifier , type in the new name and click Apply . The new name is shown on the tile on the startup page.
Enable Automatic Connection Activation	At Activation , select Automatic . <ul style="list-style-type: none"> • When you select Automatic at Activation and connect to the LAN or WLAN interface, the data connection is automatically established as soon as the IP NEO M is registered on the satellite network. • When you disable automatic activation (default), you can control the data connection manually from the startup page.
Change the APN for the connection	By default a connection is set to use the APN (Access Point Name) from the terminal (defined by Space42). This is suitable for most applications. If you want to use a different APN: <ol style="list-style-type: none"> 1. Under APN, select the Type of the APN. <ul style="list-style-type: none"> • Default (default and recommended setting): The APN is taken from the terminal (defined by Space42). • User defined: Type in the APN next to User defined name. The Airtime Provider provides the APNs. 2. Click Apply.
Change the Quality of Service	<ol style="list-style-type: none"> 1. Under Quality of service, Select the Traffic class from the dropdown list. <ul style="list-style-type: none"> • Standard. A shared background connection used e.g. for TCP/IP traffic such as e-mail, file transfer, and Internet/intranet access. • Streaming: An exclusive, high-priority connection, ensuring seamless transfer of data. This type of connection is ideal for e.g. live video over IP. 2. If you selected Streaming, select the Max. upload bit rate, Max. download bit rate, guaranteed upload bit rate and guaranteed download bit rate for the streaming connection. 3. Click Apply.
Delete a connection	Click Delete ¹ at the bottom of the page. Note: you cannot delete the default Standard connection.

1. If you accidentally delete a connection, you can either create a new manually or restore factory settings. Note, however, that all changes to the configuration will be lost if you restore factory settings.

3.5 Status information

If the window is large enough, it shows a status field at the bottom of the page or in the right side of the page. If not, click  at the bottom of the page to show the status page. Click  again to return to the previous page.

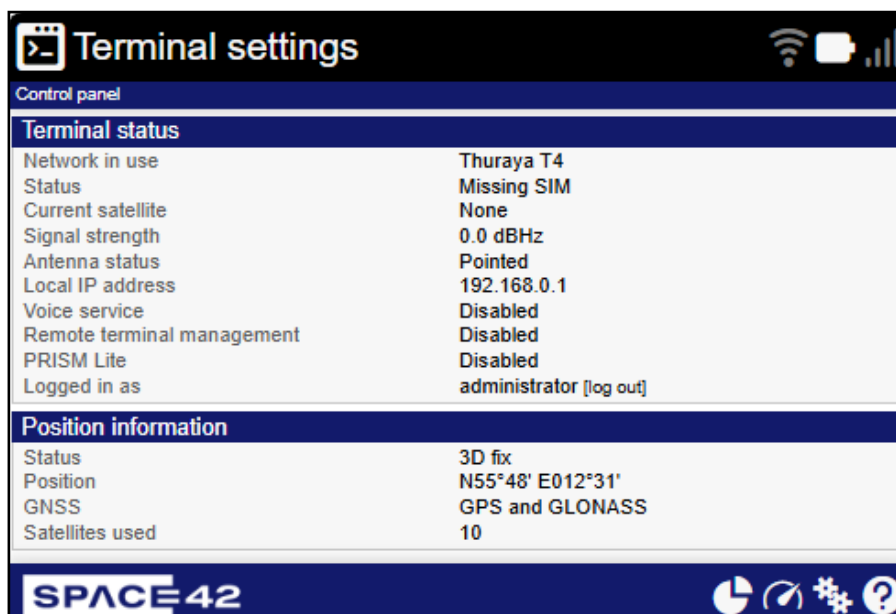

Toggle between status and contents page

The following status is available:

Terminal status:

- Network in use: The network currently used.
- Status: The status of the satellite network. Data means a data connection is running. The status could also be e.g. Registering or Ready.
- Current satellite: The satellite to which the IP NEO M is currently registered.
- Signal strength: The signal strength of the satellite connection.
- Antenna status: The status of the antenna, e.g. Pointed.
- Local IP address: The local IP address of the IP NEO M. E.g. used to connect to the web interface.
- Voice service¹: The status of the voice service, e.g. Disabled, Not registered, Registered.
- Remote terminal management: The status of Remote terminal management, e.g. Disabled, Registered or Not ready.
- PRISM Lite: The status of the PRISM Lite function, Enabled or Disabled.
- Logged in as: This field shows if you are logged in as administrator or user. You can click [log out] to log out.

Position information:

- Status: Shows the status of the GNSS connection, e.g. if there is 2D fix, 3D fix or no position fix.
- Position and GNSS: The geographic position of the IP NEO M and the position system used.
- Satellites used: Shows how many GNSS satellites are used to obtain the position.

1. Voice is only supported when connected to T4-NGS network.

Data information (only shown if a data connection is running).

- Standard data (or other connection name): Shows which type of data is running within the connection. For details on connections, see *To control data connections from web interface* on page 3-8.

Call information (only shown if a voice call is ongoing)

- Status: The status of the call, e.g. Connected or Ringing....
- Call duration: The duration of the call.
- Originator: The phone number from which the call was made.
- Receiver: The phone number that receives the call.

3.6 The Control panel

The **Control panel** is used for accessing settings and functions of your IP NEO M.

To open the **Control panel**, click  from the bottom right corner of the web interface.

Note

Some functions (e.g. Voice) are only available when T4-NGS network is selected.
Also, Stealth mode is only shown and available if supported by the SIM.



Control panel

WLAN LAN Voice

Network in use IP handsets

Logs Point now

Terminal settings Advanced LAN

Battery Advanced

Support Stealthmode

Terminal status		Position information	
Network in use	Thuraya T4	Status	3D fix
Status	Not pointed	Position	N55°48' E012°31'
Current satellite	None	GNSS	GPS and GLONASS
Signal strength	0.0 dBHz	Satellites used	11
Antenna status	Not pointed		
Local IP address	192.168.0.1		
Voice service	Disabled		
Remote terminal management	Disabled		
PRISM Lite	Disabled		
Logged in as	administrator [log out]		

SPACE 42

3.7 To select the satellite network

The IP NEO M supports the T2/T3 network and the newer T4-NGS network (available in fall 2025).

Note | Some of the features described in this manual, e.g. all voice related features, are only available with T4-NGS network.

To select the network to use from your IP NEO M:

1. From the **Control panel**, select **Network in use**.
2. Select the network you are going to use and click **Apply**. You can select **Thuraya T4** or **Thuraya T2/T3**.

Note | The terminal will reboot when you change the network.

3. Click **Apply**.

The terminal reboots and starts up with the features of the selected network enabled.

3.8 To activate Stealth mode

If Stealth mode is supported by the SIM, you can put the IP NEO M in Stealth mode. When the IP NEO M is in Stealth mode, **WLAN, LEDs and system sounds are disabled**. To activate Stealth mode:

1. From the **Control panel**, click the **Stealthmode** tile.
2. Select **Enable Stealthmode** and click **Apply**.
When Stealth is activated, the tile image is red, and a red Stealth icon appears in the status bar at the top of the page.
3. To **exit** Stealth mode, click the **Stealthmode** tile again, remove the checkmark and click **Apply**. The text and image on the tile becomes gray and the Stealth icon disappears from the status line at the top.

3.9 To use the logs

3.9.1 To access the logs

To access the Logs, select  and select **Logs** from the menu. The Logs page contains:

- **Call log**¹: A list of all incoming, outgoing and missed calls since the log was last cleared.
- **Data log**: A list of all data sessions since the log was last cleared.
- **Call statistics**¹: Totals (number of calls and duration) for calls since the log was last cleared.
- **Data statistics**: Totals (amount of data or duration) for data since the log was last cleared.

Date and time is the international UTC time, received from the satellite.

1. Voice is only supported with T4-NGS network.

3.9.2 Call log¹

The Call log shows:

- **Outgoing calls** shows the start time, receiving end phone number and duration.
- **Received calls** shows the start time, calling phone number and duration of each incoming call.
- **Missed calls** shows the start time and calling phone number of each incoming call that was not received.

The Call log also shows the termination cause for failed calls.

To clear the Call log, click the **Clear call log** button at the top.

3.9.3 Data log

The Data log shows:

- Data usage (bytes), date and time of each Standard data session.
- Duration and type (such as 64 kbps, 128 kbps), date and time of each Streaming data session.

If the connection terminates unexpectedly or cannot be started, the Data log also shows the termination cause of each data session.

To clear the Data log, click the **Clear data log** button at the top.

3.9.4 Statistics for calls¹ and data sessions

- **Call statistics** shows the number of incoming, outgoing and missed calls and the total duration (hh:mm:ss) of incoming and outgoing calls since the log was last cleared. To reset the statistics counter, click the **Reset call statistics** button at the top.
- **Data statistics** shows totals for each data connection type since the log was last cleared. For Standard data the totals are shown as amount of data transferred (kB) and for Streaming connections the totals are shown in duration (hh:mm:ss). To reset the statistics counter, click the **Reset data statistics** button at the top.

1. Voice is only supported with T4-NGS network.

3.10 Battery status information

To view the status of the internal battery, do one of the following:

- Click the battery symbol from the icon bar at the top of the page, or
- from the **Control panel** , select **Battery**.

The Battery page shows:

- **Status** (E.g. Charging, Discharging, Fully charged or Idle¹)
- **Charge level** in percent
- **Estimated remaining usage time** (not shown when external power is connected)
- **Estimated remaining charge time** (when the battery is charging)
- **Temperature**.

Note

The estimated remaining usage time can vary significantly, depending on usage. The remaining time will be shorter if the terminal is used heavily (more interfaces in use and more calls and data sessions active).

The estimated remaining usage time stated is the time that the terminal will run when the battery is active (discharging).

When the terminal is connected to external power the remaining usage time can not be estimated.

For more information on the IP NEO M battery, see

- *Normal use of the battery* on page 4-5
- *To recharge the battery* on page 4-5
- *Accurate display of the battery capacity* on page 4-5
- *Battery specifications (internal battery)* on page A-2

1. "Idle" in this case means external power is used, but the battery is not charging because the charge level was already high when power was applied.



3.11 To set up the interfaces

3.11.1 LAN interface setup

The IP NEO M has three LAN connectors:

- one standard LAN port,
- one with PoE out (e.g. for a handset), marked **LAN PoE out** and
- one with PoE in (used for powering the IP NEO M), marked **LAN PoE in**.

To configure the LAN interface:

1. In the **Control panel** , click the **LAN** icon  at the top of the page.
2. To enable the LAN interface, select **Enable** (default enabled).

Important

If you disable LAN you may not be able to access the IP NEO M. Before disabling the LAN interface, make sure you have a working WLAN connection.

You can restore the LAN and WLAN settings with the Reset button, see *Restore the settings of the IP NEO M* on page 4-4.

Note

It may take some seconds to enable the interface.



3. To enable Power over Ethernet (PoE) on the **LAN PoE out** connector, select **Enable PoE (Power over Ethernet) output** (default disabled).

If you are not using PoE, you can save power by disabling PoE.

Note

This setting is only for the **LAN PoE out** connector, **not** for the **LAN PoE in** connector.

4. Click **Apply**.

-  A line through a grayed-out **LAN** icon means the interface is **disabled**.
-  A blue **LAN** icon means the interface is **enabled**.



For a description of how to set up the **local network parameters**, see *Internet and LAN connection modes* on page 3-22 and *Advanced LAN* on page 3-25.

3.11.2 WLAN interface setup

Note

The network settings entered in the Terminal settings page also apply for the WLAN interface. See *Internet and LAN connection modes* on page 3-22.

To configure the WLAN interface:

1. In the **Control panel** , click the **WLAN** icon  at the top of the page.
2. To enable the WLAN interface, select **Enable**. (default disabled)

Important

If you disable WLAN you may not be able to access the IP NEO M. Before disabling the WLAN interface, make sure you have a working LAN connection.

You can restore the LAN and WLAN settings with the Reset button, see *Restore the settings of the IP NEO M* on page 4-4.

Note It may take some seconds to enable the interface. Note that if the WLAN settings are still default settings, the WLAN LED will now be yellow.



3. Select the **WLAN type**, 2.4 GHz (default) or 5 GHz.
 - Select 5 GHz for faster connection, if the connected equipment supports it.
 - Select 2.4 GHz if your connected equipment does not support 5 GHz.
4. Select the WLAN standard to use (all disabled by default).
For 2.4 GHz, select **802.11n** if your equipment supports it. Otherwise deselect it.
For 5 GHz, select **802.11n** or **802.11ac** or nothing, depending on your equipment.
5. Next to **Country code**, select the country you are located in (default is AE).

Note In some countries, the use of WLAN is not allowed. Before continuing, make sure WLAN is allowed and licensed in the country where you intend to use it.

Note If the IP NEO M is sold and used in the US, the country will be fixed and **not selectable**.

6. Select the **Channel** number used for communication on the WLAN interface.
For **automatic channel selection** between the legal channels in the selected country, select channel number **0** (default selected).
7. Select **Broadcast SSID** to show your WLAN access point to other users (default selected).
If you **clear** the box, your WLAN access point is hidden.
8. Type in the **SSID**.
The SSID is a max. 32 character text identifying the wireless local area network. All wireless devices on a WLAN must use the same SSID in order to communicate with each other. The default SSID is the product name followed by underscore (_) and the last 4 digits in the serial number (**IP-NEO-M_<last 4 digits of serial number>**).
9. Select the **Security** standard. You may select:
 - None (no encryption is applied), or
 - WPA2-AES (selected by default)
10. Next to **Key type**, select **Hexadecimal** or **Text**.
The encryption key must normally be a hexadecimal code. However, if you are using WPA2-AES encryption (default) you can choose to use a text string, which may be easier to memorize. **Text** is selected by default.
11. Type in the **Encryption key** for the selected Security standard (not applicable if security mode = None). The default encryption key is the **serial number** of the IP NEO M. You can find the serial number under **Control panel > Support > About** or on the label on the IP NEO M.

Important Change the encryption key to a personal code in order to keep your WLAN connection secure and protected!

12. Click **Apply**.
 -  A line through a grayed-out **WLAN** icon means the interface is **disabled**.
 -  A blue **WLAN** icon means the interface is **enabled**.

When the settings have been changed from default values to the new values, the WLAN LED changes from yellow to green (or off, if WLAN is disabled).





For a description of how to set up the **local network parameters**, see *Internet and LAN connection modes* on page 3-22 and *Advanced LAN* on page 3-25.

3.12 Voice setup¹

Your smartphone or IP handset can be set up to make and receive calls over the satellite network, using the terminal's phone number.

For details, see *To connect a phone* on page 2-16. This section describes the voice configuration of the IP NEO M terminal in the web interface.

To enable the voice service in your IP NEO M:

1. In the **Control panel** , click the **Voice** icon  at the top of the page.
2. To enable the use of the Voice service, select **Voice service enabled**.
3. Click **Apply**.
 -  A line through a grayed-out **Voice** icon means the voice service is **disabled**.
 -  A **blue Voice** icon means the interface is **enabled**.

Note When **Voice service** in the **Terminal Status** field changes to **Registered**, the Voice service is ready for use.

3.12.1 To manage IP handsets¹

This section describes how to manage IP handsets and smartphones connected to the IP NEO M.

The WLAN interface supports connection of up to 8 units (max. 4 phones). Each phone must have a local number in the range 0501 to 0504 as well as a unique password. For details, see the next section.

For details on SIP settings and how to connect your phone to the LAN or WLAN interface, see *To connect a phone* on page 2-16.

To manage phones in your IP NEO M



Do as follows:

1. Connect your phone to the terminal via LAN or WLAN. For details, see *To connect a phone* on page 2-16.
2. In the web interface, select  (**Control panel**) > **IP handsets**.
3. Click the tile for the handset number you want to manage.

Note The handset number is also the **user name** for the handset.

4. Select **Enable** to enable the handset.

Note It may take some seconds to enable the handset.

-  on the tile for your handset means the handset is disabled.
 -  on the tile for your handset means the handset is enabled.
5. To change the **Password**, simply type in the new password.
 6. Select whether or not the handset should **Notify incoming calls**.
 7. Click **Apply**.
 8. In your phone, enter the user name (local number) and the password you just entered in the IP NEO M. See the documentation for your phone for details.

The handset remains in the list after disconnecting. When the handset is connected again, it is automatically recognized and ready for use, if enabled.

1. Voice is only supported when connected to T4-NGS network.

3.13 Support features

To open the Support page, select  (Control panel) > **Support**.

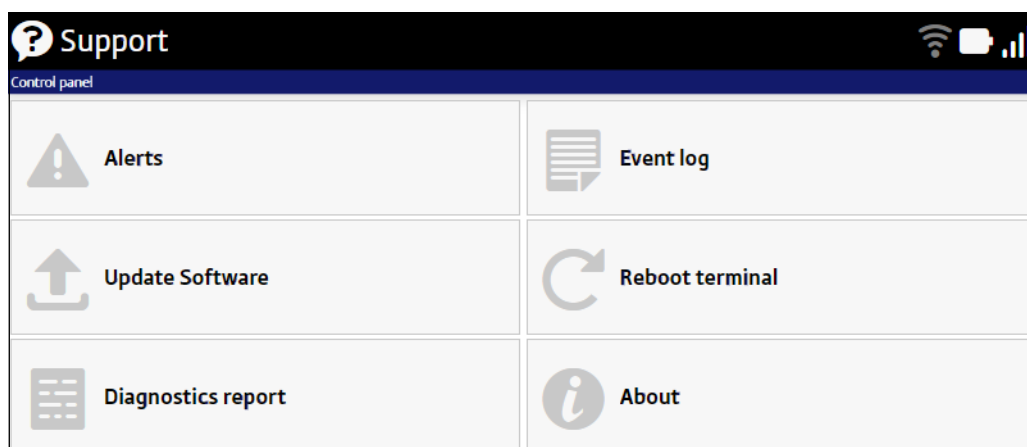

3.13.1 To view the Alerts

When an alert is registered, the web interface shows a warning icon  in the icon bar as long as the alert is active. The **Alerts** list only shows alerts that are currently active.

1. To view the alerts, click  from the icon bar at the top of the web interface, or select **Alerts** from the **Support** page.

The **Alerts** page shows a detailed list of active alerts including the time of the first occurrence, ID and severity of the alert message, and a short text describing the error. For more information on the alert messages, see *List of alert messages* on page 4-12.

3.13.2 To view the Event log

The Event log shows all events that have occurred. It includes events of informational character describing normal phases of operation for the terminal, and also activation and clearing of alerts that appear in the Alerts list.

To view the event log, select **Event log** from the **Support** page.

3.13.3 To create a diagnostics report

The diagnostic report contains relevant information for troubleshooting. When contacting your supplier for support, please enclose this file. To generate a diagnostic report:

1. From the **Support** page, click **Diagnostics report**.

Note | If you are using PRISM Lite, the diagnostics report will contain diagnostics for PRISM Lite together with the diagnostics for the terminal.

2. Click **Generate report**.

Note | It may take a few minutes to generate the report.

3. Select **Download report**.
4. Choose a location for the file and save it on your connected device.

If you are using PRISM Lite, you can also request a diagnostics report from the PRISM PTT+ Portal.

3.13.4 To update software

Important

If the battery power is 25% or less you must connect external power to the terminal before starting the software update. Once connected, do not remove power until the software update is completed.

To update the software in the IP NEO M:

1. Download the new software or acquire the software from Space42 and save it on your computer.
2. Open the web interface and enter the Control panel .
3. Click **Support** > **Update software**.
4. Click **Update software...**
5. Browse to the new software version and click **Open**. The software file has the extension “.tif”.
6. The terminal restarts and completes the software update.

Note

The update procedure takes some minutes to complete. During the software update, the Status LED is blinking blue.

You can check the software version under **Control panel** > **Support** > **About**.

See also *Over the Air software update (Only T4-NGS network)* on page 4-2 and *Recovery software update* on page 4-2.

3.13.5 To restart the terminal

If you want to restart the terminal:

1. From the **Support** page, select **Reboot terminal**.
2. Click to confirm the reboot.

The terminal restarts. Note that this is the equivalent to switching the terminal off and on again.

3.13.6 About

The **About** page shows the **Serial number**, **IMSI number**, **ICCID**, **IMEI number** and **software version** of your IP NEO M.

If you are using the PRISM Lite feature, the About page also shows the software version of the PRISM Lite you are using.

To access the About page, select **Support** > **About**.

3.14 Terminal settings

To configure the terminal settings, select  (Control panel) > **Terminal settings**.

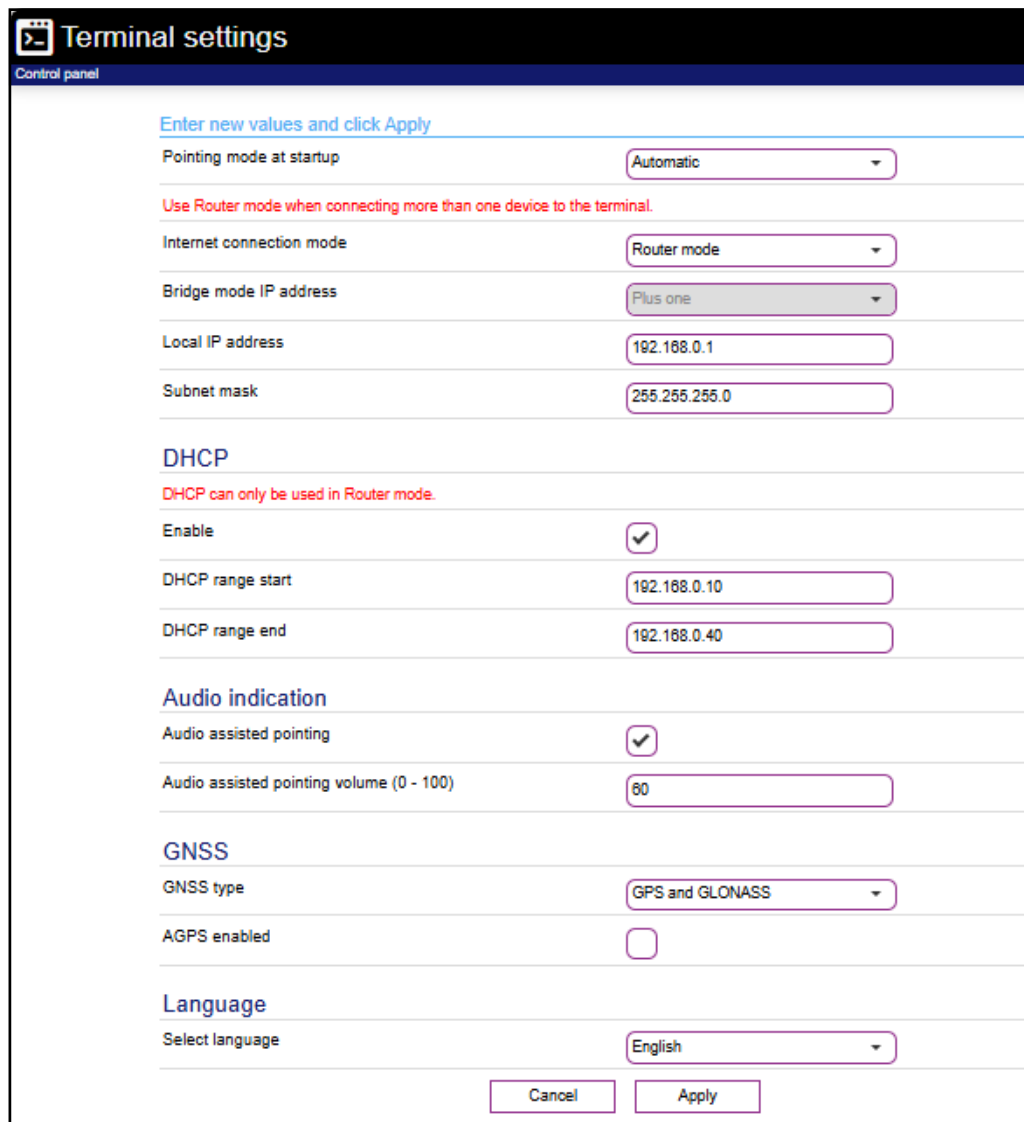

Terminal settings
Control panel

[Enter new values and click Apply](#)

Pointing mode at startup Automatic

Use Router mode when connecting more than one device to the terminal.

Internet connection mode Router mode

Bridge mode IP address Plus one

Local IP address 192.168.0.1

Subnet mask 255.255.255.0

DHCP

DHCP can only be used in Router mode.

Enable

DHCP range start 192.168.0.10

DHCP range end 192.168.0.40

Audio indication

Audio assisted pointing

Audio assisted pointing volume (0 - 100) 60

GNSS

GNSS type GPS and GLONASS

AGPS enabled

Language

Select language English

Cancel Apply

3.14.1 Pointing at start-up

You can set up the IP NEO M to automatically register on the satellite network at start-up. This is useful e.g. for semi-fixed or fixed installation, where the IP NEO M is not moved around between start-ups. See *Fixed installation* on page 2-3.

- In the **Terminal settings** page, at **Pointing mode at startup**, select **Automatic** or **Manual**.
 - If the IP NEO M is moved around between each power up, select **Manual** from the drop-down list (default). With this setting, the terminal will go through the pointing procedure every time the terminal is powered.
 - If the IP NEO M antenna is placed in a fixed position and the signal strength is sufficient, select **Automatic** to make the IP NEO M automatically register on the satellite network when the terminal is powered.
- Click **Apply**.

3.14.2 To set up the connection mode

Internet and LAN connection modes

In the web interface you can set up the Internet connection mode and the IP addressing between the IP NEO M and devices connected to the IP NEO M. The IP NEO M has a built-in DHCP server which can be used to dynamically assign IP addresses to devices connected to the IP NEO M.

The drawing below shows examples of the IP addressing in router mode (default setup) and Bridge mode.

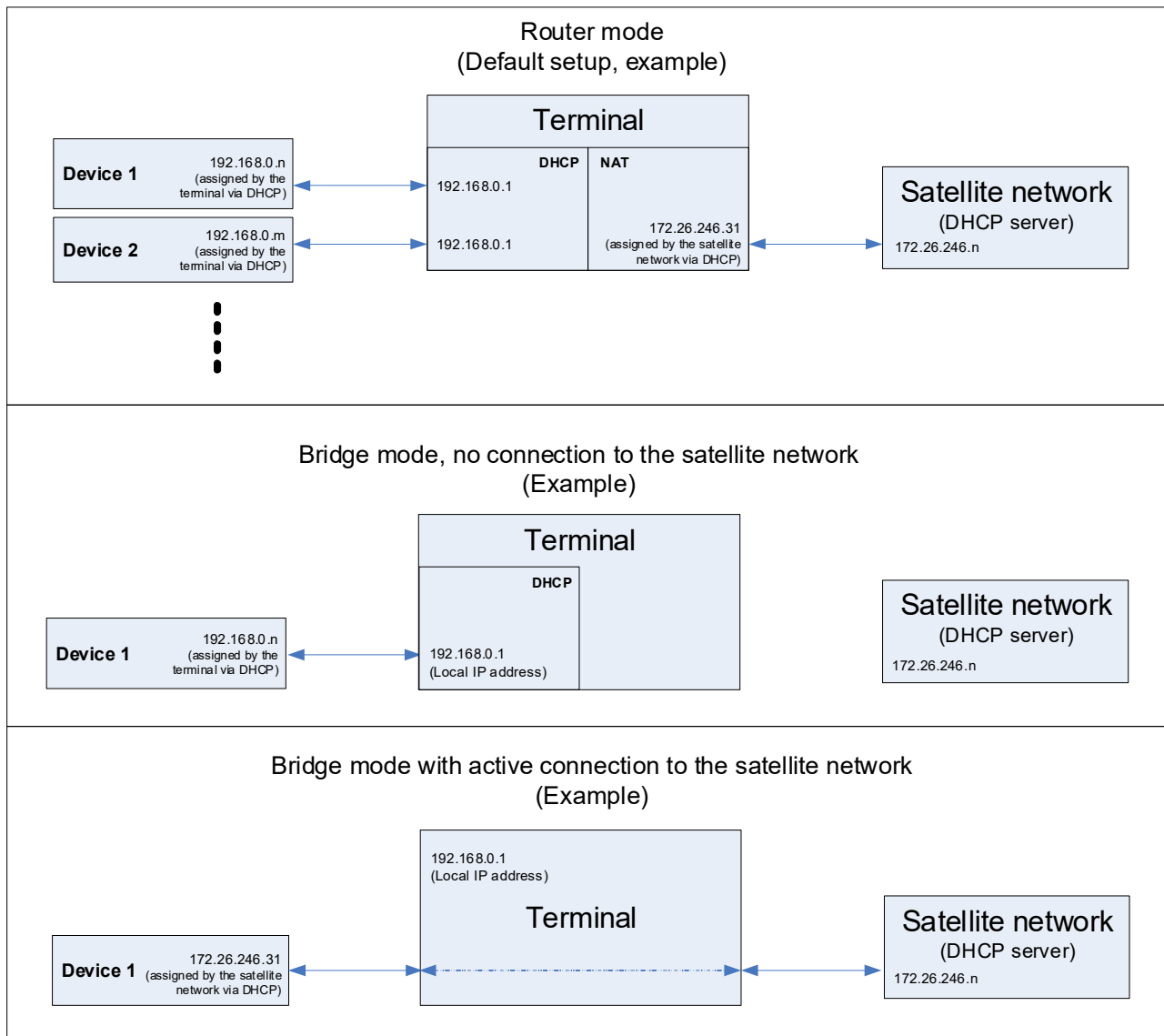

To set up the Internet connection mode of the IP NEO M:

1. In the **Terminal settings** page, at **Internet connection mode**, select **Bridge mode** or **Router mode**. Router mode is the default setting and is recommended for most purposes.
 - Select **Router mode** if one or more computers are connected and the IP NEO M should act as a router. When Router mode is selected, the IP NEO M uses the built-in NAT module for making the necessary address translations.
 - Select **Bridge mode** if only one computer is connected, and the IP NEO M should act as a modem, or if more than one computer is connected using an external router.

Note

Do **not** connect more than one computer in Bridge mode, unless you have an external router.

2. If you selected **Bridge mode**, select under **Bridge mode IP address** how the terminal's IP address should be assigned.
 - **Dynamic** example: If the IP address assigned by the DHCP server to the locally connected equipment is 10.30.27.130, the terminal will get the IP address 10.40.27.130. (in most cases it will be 10 added to the second octet of the assigned IP address).
 - **Plus one** example (default): If the IP address assigned by the DHCP server to the locally connected equipment is 172.26.246.30, the terminal will get the IP address 172.26.246.31 (the assigned IP address plus one).
3. Under **Local IP address**, type in a new IP address if you want to change the Local IP address of the terminal. This is the address used to access the web interface. The default IP address is **192.168.0.1**.

Important

When you change the local IP address and click Apply you will no longer have access to the web interface! You must type in the new IP address in your browser to regain access.

4. If you want to change the **Subnet mask** for the local network of the terminal, type in the new network mask. The default network mask is **255.255.255.0**.
5. Under **DHCP**, select **Enable** (default and recommended for most purposes).
 - If you select **Enable**, the terminal assigns dynamic IP addresses to devices connected to the terminal.
 - If you **disable DHCP** you need to set up a static IP address in the connected device.
6. Under **DHCP range start** and **DHCP range end**, type in the range of IP addresses that should be assigned to locally connected equipment.
7. Click **Apply**.

3.14.3 To enable or disable the pointing sound

The IP NEO M can make a sound to guide you through the pointing procedure (default enabled). To enable or disable the pointing sound:

1. In the **Terminal settings** page, locate the **Audio indication** section.
2. Select **Audio assisted pointing** if you want to use a pointing sound to assist your pointing process (default selected).
3. At **Audio assisted pointing volume (0 - 100)** type the volume level you want for the pointing sound (default is 60).
4. Click **Apply**.

3.14.4 To select the type of navigation system (GNSS)

To select which navigation system(s) to use with your IP NEO M:

1. In the **Terminal settings** page, locate the **GNSS** section (Global Navigation Satellite System).
2. Select a navigation system, or combination of navigation systems, from the list. There are various combinations of GPS, GLONASS, Galileo and BeiDou. Default is **GPS and GLONASS**.
3. If you want to use Assisted GPS, select **AGPS enabled**.
4. Click **Apply**.

Note

It may take some minutes for the IP NEO M to change the navigation system.

3.14.5 To select the language

The default language of the web interface is **English**. You can change the language to **Arabic, Chinese, French, Japanese, Portuguese, Russian** or **Spanish**.

To change the language:

1. In the **Terminal settings** page, locate the **Language** section.
2. Select a language from the list and click **Apply**.

3.15 Advanced LAN

3.15.1 Port forwarding

Note | Make the port forwarding configuration before starting the data session.

Port forwarding enables you to set up a server connected to the terminal while the terminal is in Router mode. Without port forwarding it would not be possible to contact the server from the Internet. We recommend using a static public IP address for the terminal in order to provide easy access to the terminal. To use the static IP address, it must be included in your subscription and you must set the APN source to Default. For details, see *Change the APN for the connection* on page 3-10.

The following example shows how to allow Internet access to a mail server (smtp) connected to the terminal.

The mail server in this example has the IP address 192.167.0.100.

1. From the **Control panel** , select **Advanced LAN > Port forwarding**.
2. Select **Forward port** to add a new port forwarding.
3. Select **Active** to activate the port forwarding (default not active).
4. Type in the **Incoming port start** and the **Incoming port end**.
This is the range of port numbers on the IP NEO M for which incoming traffic to the IP NEO M will be forwarded.
5. Type in the **Destination IP address**, which in this example is the IP address of the mail server: 192.167.0.100.
This is the IP address to which the incoming traffic is forwarded.
6. Type in the **Destination port start** and the **Destination port end**.
This is the range of port numbers, in this example on the mail server, to which the incoming traffic will be forwarded.
7. Click **Apply**.

When you have activated a data connection, you can now access the mail server from the Internet, using the external IP address of the terminal. You can see the external IP address in the tile with the data connection you have started. For information on how to activate your data connection, see *To start and stop data connections* on page 3-8.

3.16 Advanced settings

3.16.1 Passwords

The IP NEO M web interface is password protected at two levels: A user password and an administrator password. You will always be prompted for a password when you access the web interface. Default settings are¹:

- **user:**
User name: **user**
Password: <empty>
- **administrator:**
User name: **administrator**
Password: <**serial number of the IP NEO M**>

You can change the passwords if you are logged in as administrator, see the next sections.

For details on the access rights on the different user levels, see *Access levels for the web interface* on page 3-2.

To log in as user

When you log in as user you cannot change the configuration, but you can see all settings, except the Advanced settings. You can also start and stop data connections.

You are prompted for user id and password when accessing the web interface.

1. At **User id**, type **user**.
2. At **Password**, type the user password (by default, the user password is empty).
3. Click **OK**.

To log in as administrator

To change the configuration or to access the Advanced settings you must enter an administrator password. To log in as administrator:

If you have not yet logged in, you are prompted for a password when accessing the web interface. When prompted:

1. At **User id**, type **administrator**.
2. At **Password**, type the administrator password (default: the serial number of the IP NEO M).
3. Click **OK**.

If you are already logged in as user:

1. From the Control panel , select **Advanced**.
You are now prompted to log in as administrator.
2. Enter the administrator password.
3. Click **Login**.

Note

After logging in with the default administrator password, you are forced to change the password, for security reasons.

-
1. If you have forgotten the password you can restore the terminal to factory default settings. Before doing so, be aware that all settings will be restored and you will lose any configuration you may have entered.

To log out as administrator

To log out, click **Log out administrator** in the **Advanced** page or click [log out] next to administrator in the **Terminal status** field.

To change the administrator password

To change the administrator password:

1. Log in as administrator.
2. Under **Advanced**, select **Passwords** > **Change administrator password**.
3. Type in the **Old password**.
4. Type in the **New password** and retype it on the next line.

Rules for new password:

- Minimum length: 4 characters
- Maximum length: 50 characters
- Valid characters: **0-9A-Za-z** and `!$~@#%^&*()_=[{}|;:'.<>/?]-`

5. Click **Apply**.

At the next login the new password is required.

To change the user password

To change the user password:

1. Log in as administrator.
2. Under **Advanced**, select **Passwords** > **Change user password**.
3. Type in the **User id** (default: **user**).
4. Type in the **New password** and retype it on the next line.

Rules for new password:

- Minimum length: 0 characters
- Maximum length: 50 characters
- Valid characters: **0-9A-Za-z** and `!$~@#%^&*()_=[{}|;:'.<>/?]-`

5. Click **Apply**.

At the next login the new password is required.

3.16.2 Power control

Function

In order to save battery power when the IP NEO M is battery operated, you can use the **Inactivity power save** option.

With this mode selected, the terminal will go into a power save mode when it is not used. To “wake up” the terminal again, you need a so-called **Magic Packet** (Wake-on-LAN) from your connected computer, or a short push on the Power button.

Note For optimal stand-by time in Inactivity power save mode, the PC connected by Ethernet must support and have EEE (Energy Efficient Ethernet) activated.

To enter power save mode, a number of conditions must be met:

- The terminal is in Satellite selection **T4** mode. See *To select the satellite network* on page 3-13.
- **Inactivity power save** mode is selected in the **Power Control** page (see below).
- No external power supply is connected.
- No software update is in progress.
- No open network connections, such as open web interface, SSH or active data connections.
- **WLAN** is disabled (both 2.4 GHz and 5 GHz). See *WLAN interface setup* on page 3-16.
- **PoE** (Power over Ethernet) is **disabled**. See *LAN interface setup* on page 3-16. That means attached devices requiring PoE will not be power-sourced by the terminal.
- **Voice** and **Prism Light** are **disabled**. See *Voice setup* on page 3-18 and *To enable/disable PRISM Lite in the terminal (only with T4-NGS)* on page 3-31.
- **Remote management** is **disabled**. See *To enable/disable remote management (only with T4-NGS)* on page 3-31.
- A few minutes must have passed since startup or the last reactivation from the Inactivity Power Save state.

To wake up the terminal from power save mode, you can either push the Power button briefly or send a Wake-on-LAN **Magic Packet** from a connected computer. The terminal will also wake up if the battery charge level is very low, just before depletion.

Important The computer sending the Magic Packet must be connected to a LAN port on the IP NEO M **before** the terminal enters the power save state!

Note You must manually start your data connections after waking up the terminal. See *To start and stop data connections* on page 3-8.

To set up Power control

To select the Inactivity power save mode:

1. Under **Advanced**, select **Power control**.

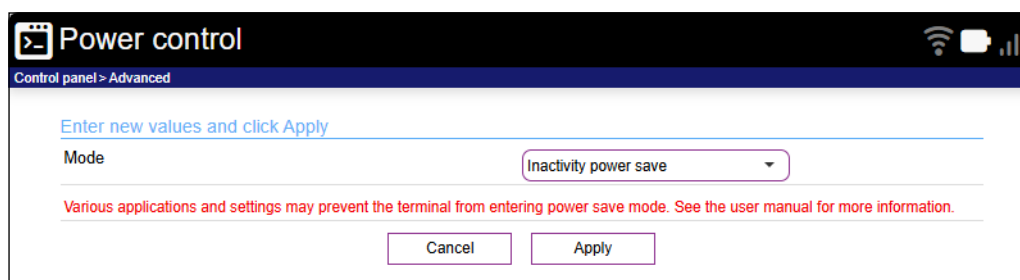

2. Select **Inactivity power save** if you want the terminal to save battery power when inactive. By default, the terminal is **Always on**, which means no power save mode is applied.
3. Click **Apply**.

When the IP NEO M is in **Inactivity power save** mode, the **Status LED** blinks green briefly every ten seconds.

3.16.3 To restore factory settings

To restore the factory settings of the IP NEO M:

1. Under **Advanced**, select **Factory reset**.

Important

All configuration will be lost and the IP NEO M will return to the default configuration.

2. Click **OK**.
The terminal will now restart and start up with the factory settings.

3.16.4 SIM for satellite network

To select the SIM mode

There are two options for the SIM:

- A physical SIM card: Nano SIM card (4FF) from your IP NEO M supplier.
- An electronic SIM card: eSIM preinstalled in the terminal.

1. Under **Advanced**, select **SIM**.
2. Click **SIM Configuration**.
3. At **SIM Mode**, select the type of SIM you are going to use.
 - **uSIM**: A physical SIM card, inserted in the IP NEO M terminal.
 - **eSIM**: An electronic SIM preinstalled in the IP NEO M terminal.
 - **Automatic**: The IP NEO M terminal automatically detects whether you are using an uSIM or an eSIM.
4. Click **Apply**.

To enable or disable the use of a SIM PIN

To enable or disable the use of a PIN to access the satellite network, do as follows:

1. Under **Advanced**, select **SIM**.
2. Select **Enable/disable SIM PIN**.
3. Under **Enable/disable PIN** select or clear the box next to **Require PIN on startup**.
 - If you **clear** the box, you can access and use the terminal without entering a PIN.
 - If you **select** the box, you must enter a PIN on startup to be able to access the network.
4. If you selected **Require PIN on startup**, type in the PIN next to **Enter current PIN**.
5. Click **Apply**.
The new PIN settings will take effect at next power on.

To change the SIM PIN

To change the PIN used to access the satellite network, do as follows:

1. Under **Advanced**, select **SIM**.
2. Select **Change SIM PIN**.
3. Under **Change PIN** type in the **Current PIN**.
4. Type in the **New PIN** and retype it on the next line.
5. Click **Apply**. The new PIN settings will take effect at next power on.

3.16.5 Security

HTTPS settings

The IP NEO M internal web server supports HTTPS, which includes encryption of the exchanged web traffic when accessing the IP NEO M web interface.

By default, the system uses a self-signed certificate, but it also allows you to upload your own certificate signed by a trusted Certificate Authority.

1. From the **Advanced** page select **Security**.

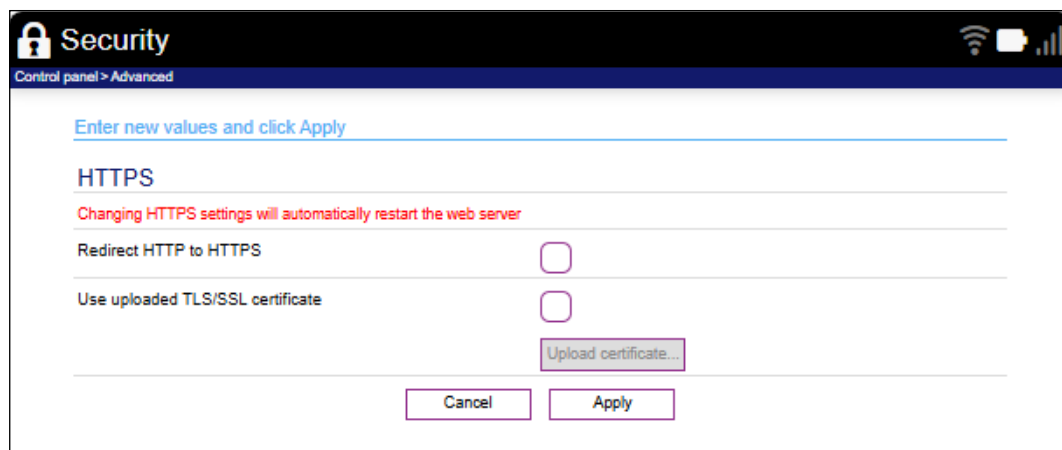

2. Select **Redirect HTTP to HTTPS** if you want the IP NEO M to automatically redirect your HTTP traffic to HTTPS (default not selected).
3. Select **Use uploaded TLS/SSL certificate** and click **Upload certificate** if you want to upload your own generated SSL certificate for the system to use (default not selected). Please note that the uploaded certificate file (.pem file format) must include the RSA private key used to generate the certificate:

```
-----BEGIN CERTIFICATE-----
...
... <your certificate here> ...
...
-----END CERTIFICATE-----
-----BEGIN RSA PRIVATE KEY-----
...
... <your key here> ...
...
-----END RSA PRIVATE KEY-----
```
4. Click **Apply**.

3.16.6 To set up AT shell

If you want to use AT commands with the terminal: To enable initial login on the AT shell, you must enable AT shell and define the password to use.

1. From the **Advanced** page select **AT shell**.

The screenshot shows a web interface for configuring the AT shell. At the top, there's a title bar with a terminal icon and the text 'AT shell'. Below that, a breadcrumb trail reads 'Control panel > Advanced'. A blue instruction line says 'Enter new values and click Apply'. There are three rows of settings: 'Enable AT shell' with an unchecked radio button, 'Change AT shell user password' with an unchecked radio button, and 'New AT shell user password' with an empty text input field. At the bottom, there are two buttons: 'Cancel' and 'Apply'.

2. Select **Enable AT shell** if you want to use AT commands with the terminal.
3. To define the password for the AT shell, select **Change atshell user password** and type in the new password under **New atshell user password**.

Rules for new password:

- Minimum length: 4 characters
- Maximum length: 50 characters
- Valid characters: **0-9A-Za-z** and ``!$~@#%^&*()_+=+[{]\|;:'.<>/?]-`

4. Click **Apply**.

3.16.7 To enable/disable remote management (only with T4-NGS)

With **Remote Terminal Manager (RTM)**, a remote operator can configure and manage several NEO terminals registered with the RTM service platform. To enable access to your IP NEO M terminal from the RTM:

1. From the **Advanced** page select **Remote management**.
2. Select **Enable remote access from management server**.
3. Click **Apply**.

The terminal now sets up a data connection reserved for remote management. This data connection is visible in the status section in the web interface (Data information field). Your IP NEO M terminal is now ready to be accessed, configured and managed from the RTM service platform. Note that the data connection for RTM can only be deactivated again by disabling **Remote access from management server** in the setting above.

3.16.8 To enable/disable PRISM Lite in the terminal (only with T4-NGS)

If you are using the IP NEO M in a PTT system, you can use the built-in PRISM Lite system controlled and configured in the PRISM PTT+ Portal. See also *Push-To-Talk (PTT) (only with T4-NGS)* on page 2-19. To enable PRISM Lite:

Note | You must have a subscription for the PTT service from your provider.

1. From the **Advanced** page select **PRISM Lite**.
2. Select **Enable PRISM Lite**.
3. Click **Apply**.

3.16.9 To enable the use of custom applications in the terminal (only T4-NGS)

Contact your provider if you want to use 3rd party software with the terminal. To enable the use of your software in the terminal:

1. From the **Advanced** page select **Custom Applications**.
2. Select **Custom Applications enabled**.
3. Enter the **Custom Applications unlock key** received from your provider.
4. Enter the **Custom Applications user password**.
5. Click **Apply**.

Maintenance and troubleshooting

This chapter describes maintenance and troubleshooting. It has the following sections:

- *Support*
- *Software update*
- *Restore the settings of the IP NEO M*
- *Maintenance*
- *Troubleshooting*
- *Log files*

4.1 Support

4.1.1 To repack for shipment

Should you need to send the product for repair, please read the below information before packing the product.

The shipping carton has been carefully designed to protect the IP NEO M and its accessories during shipment. This carton and its associated packing material should be used when repacking for shipment. Attach a tag indicating the type of service required, return address, part number and full serial number. Mark the carton FRAGILE to ensure careful handling.

Note | Correct shipment is the customer's own responsibility.

If the original shipping carton is not available, the following general instructions should be used for repacking with commercially available material.

1. Wrap the defective unit in heavy paper or plastic. Attach a tag indicating the type of service required, return address, part number and full serial number.
2. Use a strong shipping container, e.g. a double walled carton.
3. Protect the front- and rear panel with cardboard and insert a layer of shock-absorbing material between all surfaces of the equipment and the sides of the container.
4. Seal the shipping container securely.
5. Mark the shipping container FRAGILE to ensure careful handling.

Failure to do so may invalidate the warranty.

4.2 Software update

4.2.1 To update software with the web interface

Note | If possible, connect external power to the terminal before software update.

1. Download the new software or acquire the software from Space42 and save it to your computer.
2. Connect your computer to the IP NEO M.
3. Open the web interface in your browser and enter the Control panel .
4. Click **Support > Update software**.
5. Click **Update software...**
6. Browse to the new software version and click **Open**. The file has the extension “.tif”.
7. The IP NEO M now restarts and completes the software update.

You can check the software version under **Control panel > Support > About**.

Note | The update procedure takes a couple of minutes.

4.2.2 Over the Air software update (Only T4-NGS network)

If you are registered on the T4-NGS network, you can update the IP NEO M software Over the Air via https.

Note | If possible, connect external power to the terminal before starting the software update.

Over the Air software update is **only possible from an authorized Space42 server**.

There are two methods, depending on your configuration:

- RTM (Remote Terminal Management): The RTM operator can update the software in your IP NEO M from the Service Platform **Remote Terminal Manager**.

Note | Remote access must first be enabled in the IP NEO M web interface under **Control panel > Advanced > Remote management**.

- REST API
Use the command `sw/update/initiate` and enter the url for the new software. For details, see the REST API documentation for the IP NEO M (doc. number *98-182365*) attached to this PDF file.

4.2.3 Recovery software update

If the IP NEO M becomes inoperative, a recovery software update may bring it back into an operational state.

Important | The recovery software update will restore your IP NEO M configuration to factory default!

To make a recovery software update:

1. Acquire the new software and save it to your computer.
2. Connect the IP NEO M to a DC power supply before starting the software update.
3. While powering on the IP NEO M, push and hold the Reset button until the Status LED is blinking rapidly blue. See *Restore the settings of the IP NEO M* on page 4-4.

4. Connect your computer with the new software to one of the LAN connectors.

Note | WLAN is not accessible when the IP NEO M is in safe mode.

5. On the connected computer, access the web interface. The web interface will open in safe mode, which is a limited version that only supports updating software.
6. In the **Safe Mode** page, click **Choose file** and browse to the new software version on your computer and click **Open**. The file has the extension “.tiff”.
7. Click **Upload**.
8. After successful upload, the new software is installed.
9. The IP NEO M restarts and completes the software update.

Note | The update procedure can take up to 15 minutes.

10. Wait for the status LED to become steady green to indicate the software update process is completed.

4.3 Restore the settings of the IP NEO M

The IP NEO M has a Reset button that has three functions: To restore all settings to factory settings, to restore WLAN settings and Local IP address only, and to put the IP NEO M into safe mode for recovery software update.

Action	Function
Push and hold the Reset button for 2-10 seconds	<p>LAN settings: The terminal IP address and IP netmask are temporarily set to the default value (default IP address: 192.168.0.1).</p> <p>WLAN settings are restored to default.</p> <p>Default WLAN settings:</p> <ul style="list-style-type: none"> • WLAN is Disabled • Broadcast SSID: IP-NEO-M_<last 4 digits of serial number> • Encryption standard: WPA2-AES • Encryption key: serial number of the IP NEO M • Region: AE
Push and hold the Reset button for > 10 seconds	The IP NEO M restores factory settings and restarts the system. All changes to the configuration are lost.
Push and hold the Reset button while you switch on the IP NEO M.	<p>The IP NEO M enters safe mode. The Status LED is blinking rapidly blue.</p> <p>In safe mode the IP NEO M is ready for a recovery software upload through the LAN interface (see <i>Recovery software update</i> on page 4-2).</p>

The restore button is located inside a small hole covered by foil next to the SIM slot.



1. Loosen the SIM cover using a large flat-bladed screwdriver.
2. Remove the cover.
3. Remove the foil that covers the restore button (see picture above).
4. Use a pointed device to push the Reset button inside the small hole. The function depends on the length of time you hold the button, see the table above.
5. Close the cover and tighten it carefully. This is important in order to maintain the IP grade of the IP NEO M.

4.4 Maintenance

4.4.1 Normal use of the battery

Never leave the IP NEO M fully discharged for a longer period of time. If the IP NEO M is not to be used for a shorter period of time (1 month), charge the battery to minimum 20 to 30%. If the IP NEO M is stored for more than a month, charge the battery to 50%. For battery specifications, see *Battery specifications (internal battery)* on page A-2.

4.4.2 To recharge the battery

To recharge the battery, connect external power to the DC input of the IP NEO M. For details on how to apply external power, see *External power* on page 2-4.

4.4.3 Accurate display of the battery capacity

To ensure accurate display of the battery capacity, you can run a learning cycle at first time use. The learning cycle must be performed between 20°C/68°F and 30°C/86°F.

1. Fully charge the battery.
2. Remove external power and fully discharge the battery:
Use the IP NEO M and/or leave it on until it turns off automatically. This way the IP NEO M learns the complete capacity of the battery. Note that it may take several hours to discharge the battery if it is not in use.
3. Recharge the battery.

4.4.4 Cleaning the IP NEO M

Clean the exterior of the IP NEO M with a damp cloth.



CAUTION! Do not spray water directly on the IP NEO M with high pressure! The IP NEO M can be washed gently, but it is not designed to be exposed to high pressure water-jets. The IP NEO M protection is IP68 with all IP graded caps and/or connector housings mounted correctly.

4.4.5 Disposal of the IP NEO M

Old electrical and electronic equipment marked with this symbol can contain substances hazardous to human beings and the environment. Never dispose these items together with unsorted municipal waste (household waste).

In order to protect the environment and ensure the correct recycling of old equipment as well as the re-utilization of individual components, use either public collection or private collection by the local supplier of old electrical and electronic equipment marked with this symbol.

Contact the local supplier for information about what type of return system to use.

**Important**

The IP NEO M contains a Lithium Ion battery, which must be removed from the terminal before disposal. For details, see the next section.

Before disposal: Remove the battery from the IP NEO M

Important

This procedure is only for disposal of your IP NEO M. You will not be able to use the terminal after dismantling it.

Remove the battery from the IP NEO M before disposal:

1. Remove all screws in the front cover (use a Torx 10 Screwdriver).
2. Remove the front and gasket.
3. Remove all screws in the metal plate (use a Torx 10 Screwdriver).
4. Lift up the metal plate.
5. Gently remove the battery from the metal plate before disposal.

4.5 Troubleshooting

4.5.1 Troubleshooting guide

Problem	Possible cause	Remedy
The IP NEO M cannot be switched on, or does not stay on when powered by the battery.	The battery needs recharging.	Recharge the battery. Check the battery indicator in the web interface.
The IP NEO M cannot be switched off.	The Power button was not held long enough.	When you switch off the IP NEO M, hold the power button until the light indicator blinks rapidly yellow. In rare cases, it may take up to 10 seconds to switch off the IP NEO M.
Charging error	The temperature is below 0°C or above 45°C.	If the battery temperature is below 0°C or above 45°C the battery will not charge. The battery only charges between 0°C and 45°C.
	The charging voltage is lower than the specified minimum voltage.	Wait until charging begins (the Status indicator blinks yellow). If the battery is completely discharged, and it has been out of use for a long time, the charging process may take a long time to start. If charging does not begin within 2-3 hours, contact your local supplier.
The IP NEO M is not operational.	Software error	Restart the terminal. If the problem persists, you can restore factory settings as described in <i>Restore the settings of the IP NEO M</i> on page 4-4. Note: This will restore the configuration of your terminal to factory default!

Problem	Possible cause	Remedy
The web interface Terminal status shows Missing SIM .	The SIM card is not present.	Switch off the IP NEO M and insert the SIM card in the SIM slot according to the instructions in this manual.
	The SIM card is not inserted properly.	Switch off the IP NEO M and remove the SIM card and re-insert it according to the instructions in this manual.
	The SIM card is invalid	Switch off the IP NEO M and replace the SIM card with a valid SIM card.
The web interface Terminal status shows Scanning, Registering or Channel search for more than a few minutes.	The IP NEO M cannot register on the satellite network.	<p>Check your subscription with the Airtime Provider.</p> <p>Check that the signal strength is sufficient to register on the network (min. 45 dBHz)</p> <p>Check that your SIM card is valid for communication on the satellite network.</p> <p>Switch off the IP NEO M and remove and reinsert the SIM card.</p>
No signal or weak signal from the satellite.	The view to the satellite is blocked.	Make sure the IP NEO M has a clear view to the satellite. Be aware that window glass may reduce the signal level.
	The antenna is pointed in the wrong direction.	<p>Check that the antenna is pointed according to the position data.</p> <p>Adjust the position to the highest possible signal strength.</p>
<p>The IP NEO M cannot obtain its position using GNSS.</p> <p>The web interface Terminal status shows Acquiring position.</p>	<p>There is no GNSS signal, or the signal is weak.</p> <p>If the IP NEO M has not been used recently within the same location, it can take up to 10 minutes to obtain the position.</p>	<p>Check the position status in the web interface.</p> <p>To help the IP NEO M obtain position fix, it should be placed flat on an even surface pointing straight upwards, with a clear view to as much of the sky as possible.</p> <p>When the IP NEO M has obtained position fix, you can point the antenna towards the satellite.</p>

Problem	Possible cause	Remedy
Connection to the Internet cannot be established.	The signal strength is too low.	<p>Check that the antenna is pointed according to the position data.</p> <p>Adjust the position to the highest signal strength you can obtain.</p> <p>As a rule of thumb, you should have a signal strength of 45 dBHz or more to be able to make a call or data session.</p>
The web interface cannot be accessed.	The browser is configured to use a proxy server.	For Chrome : select Settings > System > Open your computer's proxy settings and select Off at Use a proxy server .
	You have entered a wrong IP address.	Check the IP address and re-enter it. The default IP address is 192.168.0.1
A LAN connection cannot be established.	The cable is not properly connected.	Connect the cable.
	The cable type or connector type is not correct.	The LAN cable must be minimum Cat. 5E or 6A with an RJ45 connector. For more details, see the section <i>To connect cables</i> in this manual.
A WLAN connection cannot be established.	The WLAN interface is disabled in the IP NEO M	Enable the interface by accessing the web interface and selecting Control panel > WLAN > Enable .
	Your computer or smartphone is placed too far away from the IP NEO M.	<p>Bring the computer closer to the IP NEO M.</p> <p>Note that the specified maximum distance is only valid under ideal conditions.</p>

4.5.2 Status signaling

Means of signaling

The IP NEO M system provides two methods for signaling the status of the system.

- **Light indicators** next to the power button.
- **Messages** shown in the web interface.

Light indicators (LED)

The IP NEO M has two light indicators showing status and WLAN.







Status indicator

Note | Errors (red constant) and Warnings (yellow constant) override other indications.

Indicator pattern		Meaning
●	Green blinking rapidly	Starting up.
●	Green blinking slowly	Power on (ready) running on internal battery.
●	Green blinking once every 3-10 seconds	Inactivity power save mode. See <i>Power control</i> on page 3-28
●	Green constant	Power on with DC input.
●	Yellow blinking slowly	Battery charging.
●	Yellow blinking rapidly	Closing down.
●	Yellow constant	Warning (user recoverable).
●	Red constant	Error. See the web interface.
●	Blue blinking slowly	Uploading software to the terminal.
●	Blue blinking rapidly	Safe mode - see <i>Restore the settings of the IP NEO M</i> on page 4-4.
○	Off	Power off.

WLAN indicator

Indicator pattern		Meaning
	Green blinking rapidly	Rx/Tx traffic.
	Green blinking slowly	In use - has WLAN registration(s).
	Green constant	Ready - customized configuration.
	Yellow constant	Ready - factory default WLAN configuration (but WLAN enabled).
	Off	WLAN disabled – or terminal power off / starting up / closing down / in safe mode.

Alert messages and status messages

In the web interface of the IP NEO M you can see status messages and alerts that are currently active.

When a warning or error alert is active, the web interface shows a warning symbol . Select it to see a list of currently active alerts.

4.5.3 List of alert messages

The following list explains some of the alert messages that may show in the web interface of the IP NEO M.

Alert ID and Severity	Displayed text	Explanation	Remedy
8056 Warning	SIM rejected ¹	You have entered too many wrong PINs and PUKs, or The type of USIM card inserted in the terminal is not correct for your terminal, or PIN code validation is enabled on your SIM card.	Contact your airtime provider. Make sure you have the correct type of USIM card for your type of terminal. Contact your provider.
8057 Warning	SIM missing	No SIM is inserted in the terminal, or the SIM is not properly inserted	Insert the SIM card as shown in <i>To insert the SIM card</i> on page 2-2.
10150 Warning	Enter PIN ²	A SIM PIN is required but has not been provided.	Enter the PIN as shown in <i>To enter the SIM PIN in the web interface</i> on page 3-7.
10151 Warning	Enter PUK ²	A PUK code is required because the PIN has been blocked (too many failed attempts).	Enter the PUK in the web interface popup window.
10152 Error	SIM card blocked ²	The SIM card is blocked, probably because of too many failed attempts.	Contact your provider.
10191 Warning	No position fix	The terminal was not able to get a position fix from the positioning system (GPS, GLONASS, Galileo or BeiDou).	It may take some time to obtain position fix. To help get position fix, place the terminal flat on a surface pointing straight upwards, with a clear view to the sky. When the terminal has position fix, point the antenna towards the satellite. You can see position status in the status section in the web interface. If the problem persists, contact your provider.
10206 Warning	Closing terminal due to high temperature	The terminal has reached a critically high temperature, and will close down by itself.	Move the terminal to a cooler location.

Alert ID and Severity	Displayed text	Explanation	Remedy
10207 Warning	Terminal temperature too low	Low ambient temperature is causing the performance of the terminal to be degraded or halted.	Move the terminal to a warmer location. For information on ambient temperature limits, see the Specifications appendix.
10209 Warning	Terminal temperature high	The temperature in the terminal is high. If it continues to go up, it may affect the performance of the terminal negatively.	If possible, move the terminal to a cooler location.
10300 Warning	Updating software...	Software update has begun.	Wait for the software update to complete.
10301 Warning	Do not remove DC power from terminal during software update	Software update is ongoing and the battery is low. Do not remove external power supply from the terminal while software update is ongoing.	If external power supply is not connected, connect it as soon as possible and leave it connected until software update is completed.
10302 Warning	Preparing for software update	Initial preparations for software upload are started.	Wait until preparations are over, either the terminal is rebooted or an error is shown.
10303 Warning	Error opening software file	The file requested to use for the update procedure cannot be opened or found.	Make sure the update file is correct and the file exists.
10304 Warning	Battery level too low for software update	The battery level is too low to perform software update.	Connect external power supply as soon as possible and leave it connected until software update is completed.
10305 Warning	Software downgrade prevented. Use a newer software version.	Not possible to perform a software downgrade, use a newer version.	Use a newer version of software for the update, or contact your provider.
10306 Warning	File does not support this product	The file used for software update does not support this terminal type.	Use the correct tiif file for your terminal.
10307 Warning	File is corrupt. Download the file again.	The file used for software update appears to be corrupt and the content cannot be validated.	Download the file again.
10308 Warning	Software update failed. Try running the update again.	Software upload failed to initialize, can be a sporadic issue.	Try running the update again. If the problem persists, contact your provider.

Alert ID and Severity	Displayed text	Explanation	Remedy
10309 Warning	Software update failed. Update to the latest software version.	The software has been rolled back to the version in use before starting this software upload. The new image was not validated correctly.	Try running the update again. If the problem persists, contact your provider.
1030A Error	Software failed. Update to the latest software version from Safe Mode.	Not all subunits have been properly verified with the new image.	Attempt software update procedure again. If not successful, update from Safe Mode as described in the section Recovery software update.
1030C Warning	Software update is already started	Another software update cycle is currently running.	Wait until the current software upload has finished.
1030D Warning	Software version is already installed	The software image you are trying to install is already active on the terminal.	Update with a different software image, or skip the update.
1030E Warning	Software update forced roll-back	Software update failed and the terminal forced a roll-back to the previous version.	Check that you have the correct file for software update and try again. If the problem persists, contact your provider.
11001 Error	Missing calibration data	Invalid calibration values found (battery-related).	Contact your provider for repair.
11002 Warning	Battery level low	The battery level is low	Charge the battery. See the section <i>To recharge the battery</i> in this manual.
11003 Warning	Temperature too low for charging	The temperature is lower than the minimum charge temperature.	Only charge the battery when the temperature is within the specified range. See the Specifications appendix.
11004 Warning	Temperature too high for charging	The temperature is higher than the maximum charge temperature.	Only charge the battery when the temperature is within the specified range. See the Specifications appendix.
18001 Warning	Failed to read IMEI	IMEI number is missing.	Contact you provider.
18002 Warning	Illegal ME	The satellite terminal used is not accepted by the network.	Contact your provider.
18003 Warning	IMEI not accepted	The satellite terminal used is not accepted by the network.	Contact your provider.

Alert ID and Severity	Displayed text	Explanation	Remedy
1812E Warning	PLMN not allowed	The terminal is not allowed to operate in the requested network.	Contact your provider.
1812F Warning	Roaming not allowed	It is not allowed to use the terminal on another operator's network.	Contact your provider.
18130 Warning	IMSI unknown in HLR	The SIM of the terminal (IMSI number) is unknown in Home Location Register	Contact your provider.
18131 Warning	IMSI unknown in VLR	The SIM of the terminal (IMSI number) is unknown in Visitor Location Register	Contact your provider.
18134 Warning	Network detached mobile	The terminal was detached by the network	Repoint the terminal. If not successful, switch the terminal off and then on again (power cycle). If the problem persists, contact your provider.
18135 Warning	Data service not allowed	The requested data service is not allowed.	If possible, use another data service. If the problem persists, contact your provider.
18136 Warning	Service not allowed	The requested service is not allowed.	If possible, use another service. If the problem persists, contact your provider.
18137 Warning	Identity cannot be derived	The identity of the terminal cannot be derived by the network.	Switch the terminal off and then on again (power cycle). If the problem persists, contact your provider.
18138 Warning	Location area not allowed	The terminal is not allowed to operate in this location area.	Switch the terminal off and then on again (power cycle). If the problem persists, contact your provider.
18139 Warning	Temporary satellite registration failure	The terminal is temporarily unable to register with the satellite network.	Wait for the terminal to retry. If not successful, replot the terminal. If the problem persists, contact your provider.
1813A Warning	General satellite registration failure	The terminal is unable to register with the satellite network.	Contact your provider

Alert ID and Severity	Displayed text	Explanation	Remedy
1813B Warning	Satellite registration retries exhausted	The terminal has attempted to register too many times without success.	Repoint the terminal. If not successful, reboot the terminal. If the problem persists, contact your provider.
18191 Warning	Satellite signal lost	The system no longer receives a signal from the satellite.	Wait for the terminal to recover the signal. If not successful, repoint the terminal (Make sure the antenna has a clear view to the satellite). If the problem persists, contact your provider.
18194 Warning	Old position	The latest geographical position registered in the terminal is old and cannot be used to register on the satellite network.	Switch the terminal off and then on again (power cycle). To help get position fix, place the terminal flat on a surface pointing straight upwards, with a clear view to the sky. When the terminal has position fix, point the antenna towards the satellite. You can see position status in the status section in the web interface. If the problem persists, contact your provider.
2BC00 Error	Hardware fault detected	A general hardware fault is detected.	Contact your provider for repair.
2BE00 Error	Missing calibration data	Invalid calibration values found (satellite connection).	Contact your provider for repair.
2C100 Error	Temperature sensor hardware fault detected	There is a hardware fault with a temperature sensor.	Switch off the terminal and contact your provider for repair.
2C600 Error	Missing calibration data	Invalid calibration values found (satellite connection).	Contact your provider for repair.
38402 Error	Hardware fault detected	A general hardware fault is detected.	Contact your provider for repair.
38403 Error	Hardware fault detected	A general hardware fault is detected.	Contact your provider for repair.
38404 Error	WLAN hardware fault detected	A hardware fault with the WLAN module is detected.	Contact your provider for repair. Note: You can still use the terminal without WLAN.

Alert ID and Severity	Displayed text	Explanation	Remedy
38407 Error	USB hardware fault detected	A hardware fault with the USB interface is detected.	Contact your provider for repair. Note: You can still use the terminal without using the USB interface.
38409 Error	Hardware fault detected	A general hardware fault is detected.	Contact your provider for repair.
3840A Error	Hardware fault detected	A general hardware fault is detected.	Contact your provider for repair.
38411 Error	GNSS hardware fault detected	There is a hardware fault with the GNSS module.	Contact your provider for repair.

1. This event only applies when connected to T2/T3 network.
2. This event only applies when connected to T4 network

4.6 Log files

4.6.1 To create a diagnostics report

The diagnostic report contains relevant information for troubleshooting. When contacting your supplier for support, please enclose this file. To generate a diagnostic report, access the web interface and select  (Control panel) > **Support** > **Diagnostics report**. See *To create a diagnostics report* on page 3-19).

Note | It may take a few minutes to generate the report.

If you are using the PRISM Lite service, you can also generate a diagnostics report from the PRISM PTT+ Portal.

4.6.2 Call log¹ and Data log

The log holds detailed information on each call or data session to and from the IP NEO M, including date and time, phone numbers, duration, amount of data transferred etc.

Date and time is UTC time, received from the satellite.

To see the log in the web interface, select  > **Logs**. See *To use the logs* on page 3-13.

4.6.3 Event log

The Event log shows events that occurred in the past and are no longer active. It includes events of informational character describing normal phases of operation for the terminal, and also alerts that have appeared in the Alerts list.

To view the event log in the web interface, select **Event log** from the **Support** page.

1. Calls are only supported when connected to T4-NGS network.

Technical specifications

A.1 General specifications

Item	Specification
Type	IP NEO M satellite terminal
Max. IP data rate, Rx/Tx ¹	T4-NGS network: 1 Mbps T2/T3 network: 444 kbps/400 kbps
Streaming data	16, 32, 64, 128, 256, 384, 512, 768, 1024 ² kbps, symmetric or asymmetric up/down
Voice ³	Via attached SIP client supporting G.711 (ulaw/alaw) voice codec.
Physical dimensions	225 x 225 x 61.5 mm 8.9 x 8.9 x 2.4 inches
Weight	2.2 kg / 4.8 lbs (incl. battery)
Operating temperature - Powered by external DC or PoE - Charging - Discharging Storage temperature - Maximum - Recommended - Recommended to maintain 80% capacity ⁴ Duration up to 1 month Duration up to 3 months Duration up to 12 months	-21°C to +55°C/ -4°F to +131°F 0°C to +45°C/ +32°F to +113°F -21°C to +55°C/ -4°F to +131°F -21°C to +50°C/ -4°F to +122°F -21°C to +25°C/ -4°F to +77°F -21°C to +50°C/ -4°F to +122°F -21°C to +40°C/ -4°F to +104°F -21°C to +25°C/ -4°F to +77°F
Water & Dust	IP68 (with recommended SIM cover, connector caps and/or connector housings)
Altitude during operation	Maximum 2000 m
Supported web browsers	Standard web browsers supported. Tested with Chrome.
Supported MIL standards	MIL-STD 461G MIL-STD 819H MIL-STD 1275D

1. Performance depends on a wide range of factors and actual usage.
2. For T2/T3 network, the max Streaming rate is 384 kbps.
3. Voice is only supported with T4-NGS network.
4. Extended storage at temperatures > 40°C/+104°F could degrade battery performance and life. The listed recommended durations and temperature ranges will maintain at least 80% recoverable capacity.

A.2 Battery specifications (internal battery)

Item	Specification
Battery type	Lithium Ion, rechargeable
Nominal voltage	10.8 V
Nominal capacity	6.9 Ah
Time between recharging Stand-by	> 14 hours
Charge time without precharging (battery is not completely discharged)	12-24V DC input: 80% in less than 2 hours, 100% in less than 3 hours LAN PoE in input: 80% in less than 4 hours, 100% in less than 6 hours
Charge time including precharging (battery completely discharged)	12 to 24 hours
Charge temperature	0°C to 45°C/ 32°F to 113°F (Japan: 10°C to 45°C/ 50°F - 113°F)
Min. charge cycles	Up to 80% of initial capacity after 800 cycles

A.3 Interfaces specifications

A.3.1 DC power input

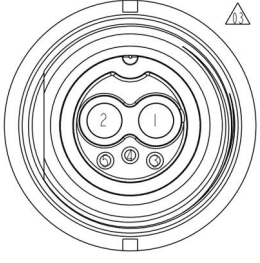
Item	Specification													
DC input range	Nominal 12 to 24 VDC (MIL-STD 1275 28 VDC), Max. range 10.8 to 33.6 VDC													
Power consumption Standby / transmit During charging	4.5 W / 22 W (typical) 75 W (max.)													
Connector type	1 x PWR connector, 13/16"-28UNS thread., IP68 when mated.													
Pin-out	<table border="1"> <thead> <tr> <th>Pin</th> <th>Function</th> </tr> </thead> <tbody> <tr> <td>1</td> <td>DC+</td> </tr> <tr> <td>2</td> <td>DC-</td> </tr> <tr> <td>3</td> <td>Not connected</td> </tr> <tr> <td>4</td> <td>Not connected</td> </tr> <tr> <td>5</td> <td>Not connected</td> </tr> </tbody> </table>	Pin	Function	1	DC+	2	DC-	3	Not connected	4	Not connected	5	Not connected	 <p>Pin Assignments Front View</p>
Pin	Function													
1	DC+													
2	DC-													
3	Not connected													
4	Not connected													
5	Not connected													

A.3.2 LAN and PoE in/out

Item	Specification
Number of connectors	3
Connector type	RJ-45 connectors, 13/16"-28UNS thread, IP68 when mated.
Standard	IEEE 802.3
Max. data rate	1000 Mbps
Max. cable length	100 m
PoE: LAN PoE in interface (PoE input) LAN PoE out interface (PoE output)	PoE++ (PD) Type 3 class 6 Minimum 50 VDC 600 mA/ pair (in total 60 W) PoE (PSE) Type 1 class 2

A.3.3 USB

Item	Specification
Version	USB 2.0, DRP
Type	Type C
Source current	Max. 500 mA

A.3.4 WLAN access point

Item	Specification
Standard	IEEE 802.11
Antenna	Built-in
Frequencies, Country selection dependent	2.412 - 2.472 MHz (EU) 2.412 - 2.462 MHz (US) 5.180 - 5.240 MHz 5.260 - 5.320 MHz 5.500 - 5.700 MHz 5.600 - 5.650 MHz (special DFS requirements) 5.735 - 5.825 MHz
Bandwidth	Max. 20 MHz, 40 MHz, 80 MHz
Modes	IEEE 802.11b/g/a/n/ac HT20/HT40/HT80
DFS frequencies	Operation as slave device supported

A.4 Built-in satellite antenna

Item	Specification
Type	Directional patch array, manually adjustable
Polarization	LHCP, Left-hand circular polarization for both tx and rx
Frequencies Transmit Receive	1626.5-1660.5 MHz. 1525.0 MHz - 1559.0 MHz.
EIRP	13.5 dBW (nominal).
GNSS	GPS, GLONASS, Galileo and Beidou.

A.5 Outline drawing

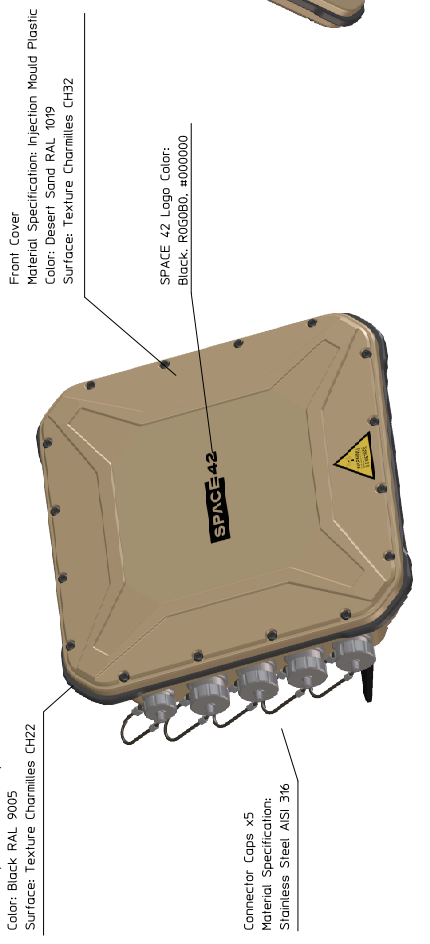
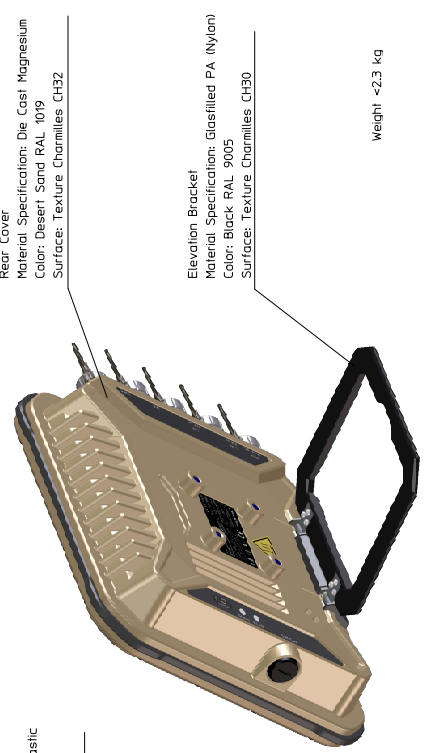
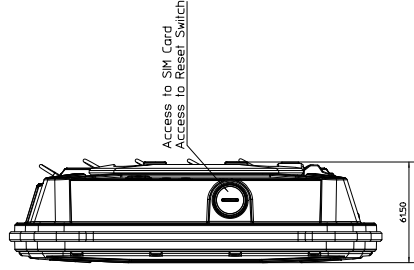
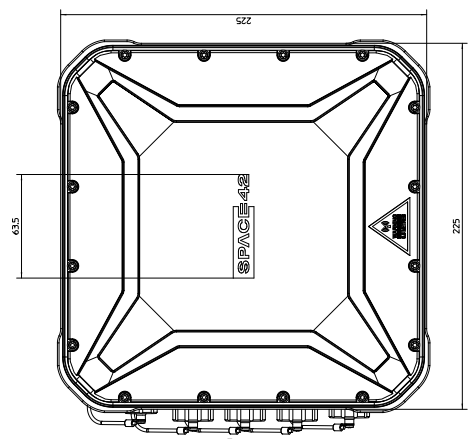
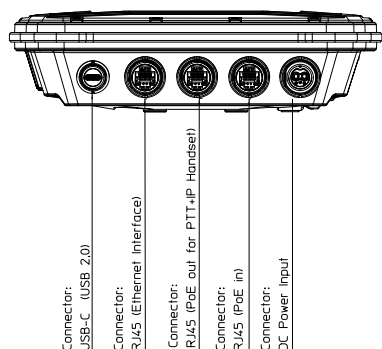
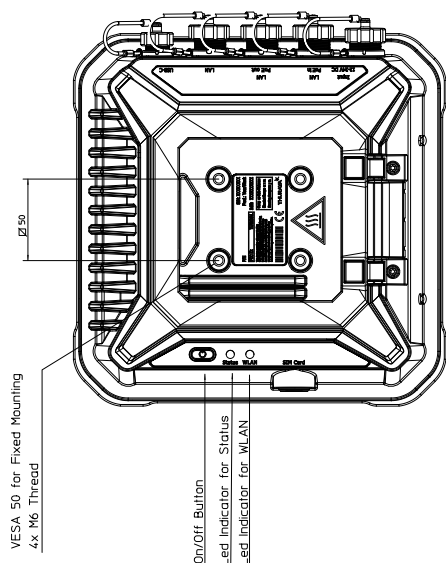

Command reference

This appendix lists the function, syntax and parameters for commands used with the IP NEO M. You can send commands to the IP NEO M via AT shell. See *To access the terminal using AT commands* on page 2-15.

Note

The use of AT shell must be enabled in the terminal. You can do this in the web interface, see *To set up AT shell* on page 3-31.

This appendix has the following sections:

- *Overview of AT commands*
- *AT commands*
 - *Syntax conventions*
 - *Identification related AT commands*
 - *Context management AT commands*
- *Configuration examples*

B.1 Overview of AT commands

Function	Command
Request manufacturer identification of the satellite terminal. (Use any one of the two commands).	+GMI +CGMI
Request model identification of the satellite terminal. (Use any one of the two commands).	+GMM +CGMM
Request Revision Identification of the satellite terminal. (Use any one of the two commands).	+GMR +CGMR
Request Product Serial Number Identification (IMEI) of the satellite terminal.	+CGSN
Request International Mobile Subscriber Identity (IMSI) of the satellite terminal.	+CIMI
Define PDP Context	+CGDCONT
PDP context read dynamic parameters	+CGCONTRDP ¹
Define Secondary PDP Context	+CGDSCONT ¹
PDP context read dynamic parameters	+CGSCONTRDP ¹
Traffic flow template read dynamic parameters	+CGTFTRDP ¹
Request the state of PS (attached or detached)	+CGATT?
PDP context activate or deactivate	+CGACT
Delete non-active PDP contexts	+CGDEL ¹
Show PDP address	+CGPADDR
Define EPS quality of service	+CGEQOS ¹
EPS quality of service read dynamic parameters	+CGEQOSRDP ¹
3G Quality of Service Profile (requested)	+CGEQREQ ²

1. This command is only supported in T4-NGS network.
2. This command is only supported in T2 and T3 network.

B.2 AT commands

The following most used AT commands are explained in this manual. Other AT commands not mentioned here may still be supported.

- *Identification related AT commands*
- *Context management AT commands*

B.2.1 Syntax conventions

Syntax definitions use the following conventions:

- <parm> indicates that a parameter (without < and >) can be filled in by the user.
- {<opt1> | <opt2> | ... } indicates that one of various options must be chosen by the user.
- [<options>] indicates that <options> may or may not be included in the command.
- Keywords and parameters are separated by commas.
Note: If parameters in the middle are left out, the commas must still be there as placeholders, e.g. <parm1>, , , <parm4> - In this case parm 2 and parm 3 are left out, but <parm4> is used. If the last parameters are left out, the commas are not needed, e.g. <parm1>, <parm2>
- String type parameters must be enclosed in quotes (“”)

B.2.2 Identification related AT commands

The identification related AT commands are “read” commands. They are written without parameters.

Possible responses for the identification related AT commands

The following tables summarize the possible responses to some of the most used AT commands for identification.

Command	Possible responses
+CGMI	<manufacturer> ERROR
+CGMM	<model> ERROR
+CGMR	<revision> ERROR
+CGSN	<sn> ERROR
+CIMI	<IMS > ERROR
+GMI	<manufacturer>
+GMM	<model>
+GMR	<revision>

Response parameters for identification related AT commands

The table below summarizes the available parameters for the AT commands for identification.

Parameter	Meaning
<IMSI>	The IMSI number of the satellite terminal
<manufacturer>	The name of the manufacturer of the satellite terminal
<model>	The model of the satellite terminal
<revision>	The revision of the satellite terminal
<sn>	The IMEI number of the satellite terminal

B.2.3 Context management AT commands

The table below summarizes some of the most used AT commands for context management. Parameters are explained in *Parameters for context management AT commands* on page B-6. For details, refer to the 3GPP standard TS 27.007.

Command	Parameters
+CGACT	[<state>[,<cid>[,<cid>[,...]]]]
+CGATT?	No parameters (this is a “read” command)
+CGCONTRDP ¹	[=<cid>]
+CGDCONT	<cid>[,<PDP_type>[,<APN>[,<PDP_addr>[,<d_comp>[,<h_comp>[,<pd1>[,[,<pdN>]]]]]]]]]
+CGDEL ¹	[=<cid>]
+CGDSCONT ¹	<cid>[,<p_cid>[,<d_comp>[,<h_comp>]]]
+CGEQOS ¹	<cid>[,<QCI>[,<DL_GBR>[,<UL_GBR>[,<DL_MBR>[,<UL_MBR>]]]]]
+CGEQOSRDP ¹	[=<cid>]
+CGEQREQ ²	<cid>[,<Traffic class>[,<UL_MBR>[,<DL_MBR>[,<UL_GBR>[,<DL_GBR>[,<Delivery order>[,<Maximum SDU size>[,<SDU error ratio>[,<Residual bit error ratio>[,<Delivery of erroneous SDUs>[,<Transfer delay>[,<Traffic handling priority>]]]]]]]]]]]]]]]]]]]]]
+CGPADDR	[=<cid>[,<cid>[,...]]]
+CGSCONTRDP ¹	[=<cid>]
+CGTFTTRDP ¹	[=<cid>]

1. This command is only supported in T4-NGS network, not in T2 and T3 network.
2. This command is not supported in T4-NGS network, only in T2 and T3 network.

Possible responses for context management AT commands

The possible responses for the context management AT commands are listed in the following table:

Command	Possible response(s)
+CGACT	OK ERROR
+CGATT?	+CGATT: <state>
+CGCONTRDP ¹	+CGCONTRDP:<cid>,<bearer_id>,<apn> [<CR><LF>+CGCONTRDP:<cid>,<bearer_id>,<apn>[...]]
+CGDCONT	OK ERROR
+CGDEL ¹	OK ERROR [+CGDEL: <cid>[,<cid>[,...]]
+CGDSCONT ¹	OK ERROR
+CGEQOS ¹	OK ERROR
+CGEQOSRDP ¹	[+CGEQOSRDP: <cid>,<QCI>, [<DL_GBR>,<UL_GBR>], [<DL_MBR>,<UL_MBR>], [<DL_AMBR>,<UL_AMBR>]] [<CR><LF>+CGEQOSRDP: <cid>,<QCI>, [<DL_GBR>,<UL_GBR>], [<DL_MBR>,<UL_MBR>], [<DL_AMBR>,<UL_AMBR>]][...]]
+CGEQREQ	OK ERROR
+CGPADDR	+CGPADDR: <cid>,<PDP_addr> [<CR><LF>+CGPADDR: <cid>,<PDP_addr> [...]]

Command	Possible response(s)
+CGSCONTRDP ¹	+CGSCONTRDP:<cid>, <p_cid>, <bearer_id> [<CR><LF>+CGSCONTRDP:<cid>,<p_cid>,<bearer_id>[...]] OK ERROR
+CGTFTRDP ¹	[+CGTFTRDP: <cid>,<packet filter identifier>, <evaluation precedence index>,<remote address and subnet mask>, <protocol number (ipv4) / next header (ipv6)>,<local port range>, <remote port range>,<ipsec security parameter index (spi)>, <type of service (tos) (ipv4) and mask / traffic class (ipv6) and mask>, <flow label (ipv6)>,<NW packet filter Identifier>,<QRI>] [<CR><LF>+CGTFTRDP: <cid>,<packet filter identifier>, <evaluation precedence index>,<remote address and subnet mask>, <protocol number (ipv4) / next header (ipv6)>,<local port range>, <remote port range>,<ipsec security parameter index (spi)>, <type of service (tos) (ipv4) and mask / traffic class (ipv6) and mask>, <flow label (ipv6)>,<NW packet filter Identifier>, <QRI>][...]]

1. This command is only supported in T4-NGS network, not in T2 and T3 network.

Parameters for context management AT commands

The table below states the main parameters for the AT commands for context management. For details, refer to the 3GPP standard TS 27.007 and ITU-T V.250.

Parameter	Values	Meaning
<APN>	<APN>	Access Point Name. A string parameter which is a logical name that is used to select the GGSN or the external packet data network. If the value is null or omitted, then the subscription value will be requested.
<cid>	<cid> (1-11)	The Context Identifier for the PDP context. A numeric parameter identifying the specific PDP context - maximum 11 PDP contexts may be defined.
<d_comp>	0	A numeric parameter that controls PDP data compression: Off (default if value is omitted)
<Delivery of erroneous SDUs>	0 1 2 3	Indicates whether SDUs detected as erroneous shall be delivered or not. No Yes No detect Subscribed value
<Delivery order>	0 1 2	Indicates whether the UMTS bearer shall provide in-sequence SDU delivery or not. No Yes Subscribed value
<DL_AMBR>	<DL_AMBR>	The APN aggregate maximum bit rate downlink (see 3GPP TS 24.301 [83]). The value is in kbit/s.

Parameter	Values	Meaning
<DL_GBR>	<DLGBR>	The guaranteed bit rate down link. The value is in kbit/s. This parameter is omitted for a non-GBR QCI.
<DL_MBR>	<DL_MBR>	The maximum bit rate down link. The value is in kbit/s. This parameter is omitted for a non-GBR QCI.
<evaluation precedence index>	<evaluation precedence index> (0-255)	The evaluation precedence index defines the order in which the traffic flow filters are applied to packets. 0 is first, then 1, 2 etc. Numeric parameter, value range from 0 to 255.
<flow label (ipv6)>	from 00000 to FFFFF	A label to identify a packet as being part of a specific flow. Numeric value in hexadecimal format. Valid for IPv6 only.
<h_comp>	0 1	A numeric parameter that controls PDP header compression Off (default if value is omitted) On NOTE: At present only one data compression algorithm (V.42bis) is provided in SNDCP. If and when other algorithms become available, a command will be provided to select one or more of these.
<ipsec security parameter index (spi)>	from 00000000 to FFFFFFFF	A numeric value in hexadecimal format from 00000000 to FFFFFFFF, used to secure IP communication.
<local port range>	0-65535.0-65535	Local port range in the form From.To (0-65535).(0-65535)
<Maximum SDU size>	Integer type; (1,2,3,...)	Indicates the maximum allowed SDU size in octets. If the parameter is set to '0' the subscribed value will be requested.
<NW packet filter Identifier>	1-16	Integer type. In EPS the value is assigned by the network when established
<p_cid>	<p_cid> (1-11)	Primary PDP Context Identifier. The primary context to which the secondary context is related. A numeric parameter which specifies a particular PDP context definition which has been specified by use of the +CGDCONT command. The parameter is local to the TE-MT interface. The list of permitted values is returned by the test form of the command.
<packet filter identifier>	<packet filter identifier> (1-8)	The packet filter identifier. Numeric parameter, value range from 1 to 8.
<pd1>, <pdN>	<pd1> <pd2> <pdN>	Zero to N string parameters whose meanings are specific to the <PDP_type> For PDP type OSP:IHOSS the following parameters are defined: <pd1> = <host> The fully formed domain name extended hostname of the Internet host. <pd2> = <port > The TCP or UDP port on the Internet host. <pd3> = <protocol> The protocol to be used over IP on the Internet - "TCP" or "UDP".

Parameter	Values	Meaning
<PDP_addr>	<PDP_address>	A string parameter that identifies the MT in the address space applicable to the PDP context. If the value is null or omitted, then a value may be provided by the TE during the PDP startup procedure or, failing that, a dynamic address will be requested. The allocated address may be read using the +CGPADDR command.
<PDP_type>	IP IPV6 PPP	Internet Protocol (IETF STD 5) Internet Protocol, version 6 (IETF RFC 2460) Point to Point Protocol (IETF STD 51)
<protocol number (ipv4) / next header (ipv6)>	0-255	The Protocol Number / Next Header attribute of a valid packet filter shall contain either an IPv4 Protocol Number or an IPv6 Next Header value. Numeric parameter, value range from 0 to 255
<QCI>	0-255	Integer type; specifies a class of EPS QoS (see TS 23.203 and TS 24.301). 0 QCI is selected by network [1 – 4]value range for guaranteed bit rate Traffic Flows 75 value for guaranteed bit rate Traffic Flows [82 – 85]value range for guaranteed bit rate Traffic Flows [5 – 9]value range for non-guaranteed bit rate Traffic Flows 79 value for non-guaranteed bit rate Traffic Flows [128 – 254]value range for Operator-specific QCIs The QCI values 65, 66, 67, 69 and 70 are not allowed to be requested by the UE. If the TE requests a QCI parameter 65, 66, 67, 69 or 70, the MT responds with result code +CME ERROR: 181 (unsupported QCI value).
<QRI>	(Integer type)	Identifies the QoS rule, see 3GPP TS 23.501 and 3GPP TS 24.501
<remote port range>	0-65535.0-65535	Remote port range in the form From.To (0-65535).(0-65535)
<Residual bit error ratio>	(String type)	Indicates the target value for the undetected bit error ratio in the delivered SDUs. If no error detection is requested, Residual bit error ratio indicates the bit error ratio in the delivered SDUs. The value is specified as "mEe". As an example a target residual bit error ratio of 5×10^{-3} would be specified as "5E3" (AT+CGEQREQ=..., "5E3", ...). "0E0" means subscribed value.
<SDU error ratio>	(String type)	Indicates the target value for the fraction of SDUs lost or detected as erroneous. SDU error ratio is defined only for conforming traffic. The value is specified as 'mEe'. As an example a target SDU error ratio of 5×10^{-3} would be specified as "5E3" (AT+CGEQREQ=..., "5E3", ...). "0E0" means subscribed value.
<state>	0 1	Deactivate or Detached Activate or Attached
<Traffic class>	1 3	Streaming Standard data (Background).
<Traffic handling priority>	Integer type; (1,2,3,...)	Specifies the relative importance for handling of all SDUs belonging to the UMTS bearer compared to the SDUs of other bearers. If the parameter is set to '0' the subscribed value will be requested

Parameter	Values	Meaning
<Transfer delay>	0 500 4000	0 ms, error correction is determined by the network 500 ms, error correction is disabled 4000 ms, error correction is applied
<type of service (tos) (ipv4) and mask / traffic class (ipv6) and mask>	(0-255).(0-255)	String type. The string is given as dot-separated numeric (0-255) parameters on the form "t.m", where "t" is the type of service or traffic class, and "m" is the mask.
<UL_AMBR>	<UL_AMBR>	The APN aggregate maximum bit rate uplink (see 3GPP TS 24.301). The value is in kbit/s.
<UL_GBR>	<UL_GBR>	The guaranteed bit rate up link. The value is in kbit/s. This parameter is omitted for a non-GBR QCI.
<UL_MBR>	<UL_MBR>	The maximum bit rate up link. The value is in kbit/s. This parameter is omitted for a non-GBR QCI.

B.3 Configuration examples

For general syntax, see *Syntax conventions* on page B-3.

For parameters, see *Parameters for context management AT commands* on page B-6.

B.3.1 To create a primary PDP context

Relevant command: **at+cgdcont**

1. To create a primary PDP context, send the command:

```
at+cgdcont=[<cid>[, <PDP_type>[, <APN>[, <PDP_addr>[, <d_comp>[, <h_comp>[, <pd1>[, [, <pdN>]]]]]]]]]]
```

Example: `at+cgdcont=1,"IP","AccessPointName"`

In this example the command specifies:

- **1:** The CID of this primary PDP context.
- **IP:** The PDP type of this PDP context. **IP** means **Internet Protocol (IETF STD 5)**.
- **AccessPointName:** The APN (Access Point Name) for the data connection.

If the command was successful, the terminal returns with the response: OK

2. To get the parameters set up for primary PDP context, send the command:

at+cgdcont?

The response for the example above will be:

```
+CGDCONT: 1, "IP", "AccessPointName", 0.0.0.0, 0, 0, "", ""
OK
```

B.3.2 To create two secondary PDP contexts attached to the primary PDP context with ID=1 (only for T4-NGS network)

Relevant command: **at+cgdscont**

1. To create a secondary PDP context attached to the primary PDP context, send the command:

```
at+cgdscont=[<cid>,<p_cid>]
```

Example: `at+cgdscont=2,1`
`at+cgdscont=4,1`

In this example, two secondary contexts are created. The first command specifies:

- **2:** The CID of this secondary PDP context.
- **1:** This secondary PDP context is attached to primary PDP context with CID **1**.

The second command specifies:

- **4:** The CID of this secondary PDP context.
- **1:** This secondary PDP context is attached to the primary PDP context with CID **1**.

If the commands are successful, the terminal returns with the response: OK

2. To get the parameters set up for secondary PDP contexts, send the command:

at+cgdscont?

The response for the example above could be:

```
+CGDSCONT: 2, 1
+CGDSCONT: 4, 1
OK
```

B.3.3 To query dynamic parameters of a selected traffic flow template (only for T4-NGS network)

Relevant command: **at+cgtftrdp**

- To query the dynamic parameters of a selected traffic flow template, send the command:
at+cgtftrdp=<cid>

Example: at+cgtftrdp=1

The response could be:

```
+CGTFTRDP: 1, 3, 0, 255.255.255.255.255.255.255.255,,,,,3,1
OK
```

In this example the response shows:

- **1:** The CID of the PDP context that the traffic flow template applies to.
- **3:** The packet filter identifier.
- **0:** The evaluation precedence index. **0** is the first traffic flow filter to be applied.
- **255.255.255.255.255.255.255.255:** The source address and subnet mask.
- **3:** The network packet filter identifier
- **1:** The QRI (QoS rule, see 3GPP TS 23.501 and 3GPP TS 24.501)

B.3.4 To query dynamic parameters of all traffic flow templates (only for T4-NGS network)

Relevant command: **at+cgtftrdp**

- To query the dynamic parameters of all defined traffic flow templates, send the command:
at+cgtftrdp

Example: at+cgtftrdp

A response could be:

```
+CGTFTRDP: 1, 3, 0, 255.255.255.255.255.255.255.255, , , , , ,
, 3, 1
+CGTFTRDP: 2, 4, 0, 255.255.255.255.255.255.255.255, , , , , ,
, 3, 1
+CGTFTRDP: 4, 4, 0, 255.255.255.255.255.255.255.255, , , , , ,
, 3, 1
OK
```

See the previous section for the meaning of the parameters.

B.3.5 To set the Quality of Service (QoS) of the PDP context (only for T4-NGS network)

Relevant command: **at+cgeqos**

- To set the Quality of Service for your PDP context, send the command:
at+cgeqos=[<cid>[,<QCI>[,<DL_GBR>,<UL_GBR>[,<DL_MBR>,<UL_MBR>]]]]

Example: at+cgeqos=1,0

In this example the parameters specify:

- **1:** The CID of the PDP context.
- **0:** The QCI (class of EPS QoS). **0** means the QoS is selected by the network.

B.3.7 To query dynamic parameters of all QoS (only for T4-NGS network)

Relevant command: **at+cgeqosrdp**

- To query the dynamic parameters of all QoS, send the command:

```
at+cgeqosrdp
```

Example: at+cgeqosrdp

A response for the QoSes defined in the previous section could be:

```
+CGEQOSRDP: 1, 0, 0, 0, 0, 0, 128, 512
```

```
+CGEQOSRDP: 2, 4, 500, 500, 0, 0, 128, 512
```

```
OK
```

In the first response, the parameters specify:

- **1**: The CID for this PDP context.
- **0**: The QCI (class of EPS QoS). **0** means the QoS is selected by the network.
- **0**: Guaranteed bit rate for download - **0** means no guaranteed bit rate is defined.
- **0**: Guaranteed bit rate for upload - **0** means no guaranteed bit rate is defined.
- **0**: Maximum bit rate for download - **0** means no maximum bit rate is defined.
- **0**: Maximum bit rate for upload - **0** means no maximum bit rate is defined.
- **128**: Aggregated bit rate for download in kbit/s.
- **512**: Aggregated bit rate for upload in kbit/s.

In the second response, the parameters specify:

- **2**: The CID for this PDP context.
- **4**: The QCI (class of EPS QoS). 1 to 4: value range for guaranteed bit rate Traffic Flows.
- **500**: Guaranteed bit rate for download in kbit/s.
- **500**: Guaranteed bit rate for upload in kbit/s.
- **0**: Maximum bit rate for download - **0** means no maximum bit rate is defined.
- **0**: Maximum bit rate for upload - **0** means no maximum bit rate is defined.
- **128**: Aggregated bit rate for download in kbit/s.
- **512**: Aggregated bit rate for upload in kbit/s.

B.3.8 To activate a PDP context

Relevant command: **at+cgact**

- To activate a PDP context, send the command:

```
at+cgact=[<state>[,<cid>[,<cid>[,...]]]]
```

Example: at+cgact=1,1

In this example, the parameters specify:

- **1**: Set the state of the PDP context to **Activated**.
- **1**: The CID of the PDP context that is going to be activated.

If the command was successful, the terminal returns with the response:

```
OK
```

B.3.9 To query the state of all PDP contexts

Relevant command: **at+cgact?**

1. To query the state (activated or deactivated) of all PDP contexts, send the command:

at+cgact?

The response could be:

+CGACT: 1, 1

+CGACT: 2, 0

+CGACT: 4, 0

OK

In these responses, the **first parameter** specifies the **CID** of the PDP context and the **second parameter** specifies whether it is **activated (1)** or **deactivated (0)**.

B.3.10 To query the IP address of an activated PDP context

Relevant command: **at+cgpaddr**

1. To query the IP address of an activated PDP context, send the command:

at+cgpaddr=<cid>

Example: at+cgpaddr=1

The response could be:

+CGPADDR: 1, 10.186.2.198

OK

The **first parameter** is the **CID** of the PDP context, the **second** is the **IP address** of the terminal in the address space applicable to the PDP context.

B.3.11 To query the state of the Packet Domain service (Attached or Detached)

Relevant command: **at+cgatt?**

1. To read the state of the Packet Domain service, send the command:

at+cgatt?

Example: at+cgatt?

Response: +cgatt: 1

In this example, the parameter **1** means the terminal is attached to the Packet Domain service.

List of default settings

This appendix lists the default configuration settings that apply after a Reset to factory default.

Item	Default settings
LAN	
Enable/Disable LAN	LAN is enabled
Enable/Disable PoE	PoE is disabled
Advanced LAN	
Port forwarding	
Active	Not active
Incoming port start	<empty>
Incoming port end	<empty>
Destination IP Addr	<empty>
Dest. port start	<empty>
Dest. port end	<empty>
WLAN	
Enable/ Disable	WLAN is disabled
WLAN type	2.4 GHz (Default)
WLAN standard	For 2.4 GHz, 802.11n (Disabled); For 5Ghz - 802.11n (Disabled), 802.11ac (Disabled)
Country code	AE
Channel number	0
Broadcast SSID	Selected
SSID	IP-NEO-M_ <last 4 digits of serial number>
Security standard	WPA2-AES
Key type (HEX or text)	Text
Encryption key	<serial number of the IP NEO M>
Voice	
Enable/ Disable	Voice is disabled

Item	Default settings
IP handsets	
Handset enable/disable	Handset 0501 enabled, all other handsets disabled
Password	Same as user name/local number, i.e., 0501, 0502, 0503, or 0504
Notify incoming calls	Selected
Network in use	
Satellite network, Network in use	Thuraya T4
Stealth mode	
Enable Stealth mode	Disabled (not selected)
Logs	All logs cleared
Terminal settings	
Pointing at startup	Manual
Internet connection mode	Router mode
Bridge mode IP address	(Plus one) - not applicable, Router mode is default
Local IP address	192.168.0.1
Subnet mask	255.255.255.0
DHCP	
Enable	Enabled
DHCP range start	192.168.0.10
DHCP range end	192.168.0.40
Audio indication	
Audio assisted pointing	Enabled
Aud. as. pointing volume	60 (scale 0-100)
GNSS	
GNSS type	GPS and GLONASS
AGPS enabled	Not selected
Language	English

Item	Default settings
Advanced	
Passwords	
Normal user	
User id	user
Password	<empty>
Administrator	
User id	administrator
Password	<serial number of the terminal>
Power control	
Mode	Always on (no power save function)
SIM Configuration, SIM Mode	
Enable/disable SIM PIN	Require PIN on startup NOT selected
Security	
HTTPS settings	
Redirect HTTP to HTTPS	Not selected
Use uploaded TLS/SSL certificate	Not selected
AT shell	
Enable AT shell	Not selected (Disabled)
Change AT shell user password	Not selected
New AT shell user password	<empty>
Remote Terminal Manager	
Enable remote access from management server	Disabled (not selected)
PRISM Lite	
Enable PRISM Lite	Disabled (not selected)
Custom applications	
Custom applications enabled	Disabled (not selected)
Custom applications unlock key	<empty>
Custom applications user password	<empty>

Item	Default settings
Connections (dashboard)	
Connections on Dashboard	Standard data Streaming 16 kbps Streaming 32 kbps Streaming 64 kbps Streaming 128 kbps Streaming 256 kbps Streaming 384 kbps Streaming 512 kbps Streaming 768 kbps Streaming 1024 kbps
Identifier	<empty>
Activation	
Automatic	Not selected (data connections must be started manually)
APN	
Type	Default (The APN is taken from the terminal, defined by Space42).
User defined name	<empty>
Quality of service	
Traffic class	Standard (shared background connection)
Max. bit rate upload	<empty> (only applicable for Streaming)
Max. bit rate download	<empty> (only applicable for Streaming)
Guaranteed bit rate upload	<empty> (only applicable for Streaming)
Guaranteed bit rate download	<empty> (only applicable for Streaming)

Conformity

Certificates of approval will be available in partnerportal.cobhamsatcom.com, or from your supplier.

D.1 CE

The IP NEO M is CE certified as stated in the “EU Declaration of Conformity”.

The WLAN interface is CE certified through the manufacturer of the WLAN card.

Use of WLAN:

The WLAN interface requires that the user enters the current country of operation. See *WLAN interface setup* on page 3-16.

D.2 RCM, Australia

The IP NEO M is RCM certified as stated in the “Certificate/Declaration of Conformance RCM”.

D.3 FCC

FCC e-label:

Model: 8022A

Space42 IP NEO M Terminal

FCC ID: ROJ-8020A

Contains FCC ID: TLZ-CM276NF

Note: This equipment has been tested and found to comply with the limits for a Class B digital device, pursuant to part 15C and part 15E of the FCC Rules. These limits are designed to provide reasonable protection against harmful interference in a residential installation. This equipment generates, uses and can radiate radio frequency energy and, if not installed and used in accordance with the instructions, may cause harmful interference to radio communications. However, there is no guarantee that interference will not occur in a particular installation. If this equipment does cause harmful interference to radio or television reception, which can be determined by turning the equipment off and on, the user is encouraged to try to correct the interference by one or more of the following measures:

- Reorient or relocate the receiving antenna
- Increase the separation between the equipment and receiver
- Connect the equipment into an outlet on a circuit different from that to which the receiver is connected
- Consult the dealer or an experienced radio/TV technician for help

NOTICE:

This device complies with Part 15C and part 15E of the FCC Rules.

Operation is subject to the following two conditions:

(1) this device may not cause harmful interference, and

(2) this device must accept any interference received, including interference that may cause undesired operation.

NOTICE:

Changes or modifications made to this equipment not expressly approved by Cobham Satcom may void the FCC authorization to operate this equipment.

D.4 Safety CB certificate

The IP NEO M is certified as stated in the CB Test Certificate.

A

APN Access Point Name. The Access Point Name is used by the terminal operator to establish the connection to the required destination network.

AT AT Commands or 'Attention' Commands is the basis of communication between any cellular or RF modem and its host controller.

C

cid Context Identifier

D

DHCP Dynamic Host Configuration Protocol. A protocol for assigning dynamic IP addresses to devices on a network. With dynamic addressing, a device can have a different IP address every time it connects to the network.

DRP Dual-Role Power. A port that can operate as either a sink or source, and may alternate between these two states.

E

EPS Evolved Packet System. Also called Universal Mobile Telecommunications Service (UMTS) is a third-generation (3G) broadband, packet-based transmission of text, digitized voice, video, and multimedia at data rates up to 2 megabits per second (Mbps) which offers a consistent set of services to mobile computer and phone users, no matter where they are located in the world. It allows computers and phones to be constantly attached to the Internet wherever they travel (roam) with access through a combination of terrestrial wireless and satellite transmissions.

F

FCC Federal Communications Commission. An independent agency of the United States government, created by Congressional statute to regulate interstate communications by radio, television, wire, satellite, and cable in all 50 states, the District of Columbia and U.S. territories.

G

GBR Guaranteed bit rate (streaming rate)

GGSN Gateway GPRS Support Node. The GGSN converts the incoming data traffic coming from the mobile users through the Service gateway GPRS support node (SGSN) and forwards it to the relevant network, and vice versa. The GGSN and the SGSN together form the GPRS support nodes (GSN)

GNSS Global Navigation Satellite System. A navigation satellite system using the GPS, GLONASS, Galileo or Beidou system.

H

HLR Home Location Register. The HLR contains information regarding users who are registered as subscribers in the area, whereas the VLR contains information regarding users who are registered as subscribers somewhere else but are roaming in the area.

HTTP HyperText Transfer Protocol. HTTP is the underlying protocol used by the World Wide Web. This protocol defines how messages are formatted and transmitted, and what actions Web servers

and browsers should take in response to various commands.

HTTPS Hypertext Transfer Protocol Secure (HTTPS) is an extension of the Hypertext Transfer Protocol (HTTP). It is used for secure communication over a computer network, and is widely used on the Internet.

I

ICCID Integrated Circuit Card Identification (SIM card number)

IMEI International Mobile Equipment Identity. A unique number identifying your terminal.

IMSI International Mobile Subscriber Identity. A number used to identify the user of a cellular network. It is a unique identification associated with all cellular networks.

IP Ingress Protection. An international classification system for the sealing effectiveness of enclosures of electrical equipment against the intrusion into the equipment of foreign bodies (i.e. tools, dust, fingers) and moisture.

IP Internet Protocol

ipsec Internet Protocol Security. A protocol suite for securing Internet Protocol (IP) communications by authenticating and encrypting each IP packet of a communication session.

ISP Internet Service Provider

L

LAN Local Area Network. A computer network covering a small physical area, like a home, office, school or airport.

LED Light Emitting Diode

M

MBR Maximum bit rate

ME Mobile Equipment. In this case, your satellite terminal

MT Mobile Terminal

N

NAT Network Address Translation. An Internet standard that enables a local-area network to use one set of IP addresses for internal traffic and a second set of addresses for external traffic. A NAT module makes all necessary address translations.

O

OSP:IHOSS Octet Stream Protocol for Internet Hosted Octet Stream Service

P

PDP Packet Data Protocol. A network protocol used by external packet data networks that communicate with a GPRS network.

PIN Personal Identification Number. A code number used to provide access to a system that has restricted access.

PLMN Public Land Mobile Network. A term used to describe all mobile wireless networks that use earth-based stations rather than satellites.

PoE	Power over Ethernet
PPPoE	Point-to-Point Protocol over Ethernet
PRISM	Private Routing and Intelligent System Management
PTT	Push-To-Talk. A means of instantaneous communication commonly employed in wireless cellular phone services that uses a button to switch a device from voice transmission mode to voice reception mode. Multiple parties to the conversation may also be included.

Q

QCI	Quality of service Class (see 3GPP TS 23.203 and 3GPP TS 24.301)
QoS	Quality of Service

R

REST	Representational State Transfer. REST API is an application programming interface (API) that conforms to the constraints of REST architectural style and allows for interaction with RESTful web services.
------	--

S

SDU	Service Data Unit
SIM	Subscriber Identity Module. The SIM provides secure storing of the key identifying a mobile phone service subscriber but also subscription information and preferences.
SIP	Session Initiation Protocol. An application-layer control (signaling) protocol for creating, modifying, and terminating sessions with one or more participants. Used e.g. for Internet telephony.
SNDTCP	Sub Network Dependent Convergence Protocol, is part of layer 3 of a GPRS protocol specification. SNDTCP interfaces to the Internet Protocol at the top, and to the GPRS-specific Logical Link Control (LLC) protocol at the bottom.
SSH	Secure Shell. A network protocol that provides a secure way for two computers to connect remotely. SSH employs encryption to ensure that hackers cannot interpret the traffic between two connected devices.
SSID	Service Set Identifier. WLAN network name, used to identify the network for users connecting to it.
SSL	Secure Sockets Layer. The standard technology for keeping an Internet connection secure and safeguarding any sensitive data that is being sent between two systems.

T

TCP	Transmission Control Protocol. One of the core protocols of the Internet protocol suite. TCP provides reliable, in-order delivery of a stream of bytes, making it suitable for applications like file transfer and e-mail.
TE	Terminal Equipment
TLS	Transport Layer Security. An updated, more secure, version of SSL.

U

UDP	User Datagram Protocol. Part of the TCP/IP suite of protocols used for data transferring. UDP doesn't acknowledge that the packets being sent have been received. For this reason, the UDP
-----	--

protocol is typically used for streaming media. While you might see skips in video or hear some fuzz in audio clips, UDP transmission prevents the playback from stopping completely.

UE User Equipment

UMTS Universal Mobile Telecommunications System

UTC Coordinated Universal Time. The International Atomic Time (TAI) with leap seconds added at irregular intervals to compensate for the Earth's slowing rotation. Leap seconds are used to allow UTC to closely track UT1, which is mean solar time at the Royal Observatory, Greenwich.

V

VDC Volt DC (Direct Current)

VLR Visitor Location Register. See HLR

VPN Virtual Private Network. A network that is constructed by using public wires to connect nodes. You can create networks using the Internet for transporting data, using security mechanisms so that only authorized users can access the network.

W

WLAN Wireless LAN. A wireless computer network that links two or more devices using a wireless distribution method within a limited area such as a home, school, or office building.

Numerics

3rd party software
 enable in terminal3-32

A

Access levels for web interface3-2
 access using AT commands2-15
 accessories1-5
 admin password
 change3-27
 log in3-26
 log out3-27
 advanced settings3-26
 AGPS
 enable3-24
 alerts
 view in web interface2-20, 3-19
 antenna
 short description1-4
 APN
 set up for satellite3-10
 AT commands
 access with IP2-15
 enable AT shell3-31
 set up3-31
 audio assisted pointing2-10
 automatic activation3-10

B

battery
 capacity display accuracy4-5
 charge4-5
 short description1-4
 specificationsA-2
 bridge mode3-23

C

call log3-14
 calls
 make2-17
 missed, received, outgoing3-14
 CE complianceD-1
 charge
 IP NEO M battery4-5
 configuration
 LAN3-16
 PoE (out) enable3-16
 WLAN3-16

conformityD-1
 connect a phone
 WLAN2-16
 connectors
 DC inputA-3
 LAN and PoE in/outA-3
 overview1-3
 USBA-4
 Control panel in web interface3-12
 custom applications
 enable in terminal3-32

D

data
 log3-14
 Standard, definition2-12
 Streaming definition2-12
 total usage3-14
 data connections
 start and stop in web interface3-8
 DC input2-4
 connectorA-3
 default IP address2-8, 3-2
 default settings, listC-1
 delivery contents2-1
 diagnostics report
 create3-19, 4-17
 disposal4-6

E

eSIM3-29
 Event log3-19

F

factory settings
 restore3-29
 FCC complianceD-1
 fixed installation2-3
 fixed position for terminal2-3
 forward port3-25
 frequencies
 satelliteA-4

G

GNSS
 select system3-24
 troubleshooting4-8

H

HTTP, redirect to HTTPS 3-30

I

included items 2-1

indicator

 Status 4-10

 WLAN 4-11

initial inspection 2-1

insert SIM card 2-2

Internet connection mode

 setting 3-23

IP address

 for web interface 2-8, 3-2

 local, setting up 3-23

IP handset

 set up 3-18

 SIP settings 2-17

items included 2-1

L

LAN

 configure 3-16

 connect an IP handset 2-16

LAN connectors A-3

language

 change in web interface 3-24

LEDs 4-10

 Status 4-10

 WLAN 4-11

light indicators 4-10

log

 of calls 3-14

 of data connections 3-14

 of events 3-19

log in as administrator 3-26

log out as administrator 3-27

M

menu tree for web interface 3-5

N

navigation in web interface 3-4

O

options 1-5

Overview of the terminal 1-3

P

part numbers 1-5

password

 for AT shell 3-31

 for web interface 3-26

 access rights 3-2

 change 3-27

 log in 3-26

 log out 3-27

phone

 connect to WLAN 2-16

 SIP settings 2-17

phone call 2-17

PIN

 change 3-29

 enable or disable 3-29

 enter in web interface 3-7

PoE (in) 2-5

PoE (out) enable 3-16

point the antenna again 2-11

pointing

 audio assisted 2-10

 restarting 2-11

port forwarding 3-25

position

 select system 3-24

 troubleshooting 4-8

Power connector A-3

Power over Ethernet input 2-5

power save feature 3-28

power supply

 DC input 2-4

 PoE (in) 2-5

PRISM Lite 2-19

 enable 3-31

PTT with PRISM Lite 2-19

R

RCM compliance D-1

recovery

 software 4-2

remote management 3-31

remove SIM card 2-2

repoint the antenna 2-11

report

 diagnostics 3-19, 4-17

REST API

 doc. number -iv

 short description 1-4

restore factory settings 3-29

router mode 3-23

RTM

 enable in terminal 3-31

S

safety summary	-ii
satellite	
frequencies	A-4
save power	3-28
settings	
in web interface	3-12
restore	3-29
silent mode	2-19
SIM	
select mode	3-29
SIM card	
insert	2-2
remove	2-2
short description	1-4
SIP settings	2-17
smartphone	
connect for calls	2-16
SIP settings	2-17
software	
over-the-air update	4-2
recovery	4-2
update with web interface	3-20, 4-2
sound during pointing	2-10
SSID	
change	3-17
default name	4-4
Standard data	
definition	2-12
Status	
view in web interface	3-11
Status indicator	4-10
Stealth mode	2-19
Streaming data	
definition	2-12

T

terminal overview	1-3
total usage	3-14
troubleshooting	4-7
typography used in this manual	-iv

U

update software	3-20, 4-2
over-the-air	4-2
usage	
data	3-14
USB connector	A-4
user password	
change	3-27
uSIM	3-29

V

voice	
enable	3-18

W

warning messages	2-20, 3-19
web interface	
access levels	3-2
accessing	3-2
change language	3-24
definition	3-2
menu tree	3-5
navigating	3-4
what's in the delivery package	2-1
WLAN	
automatic activation of	3-10
configure	3-16
default network name (SSID)	4-4
default settings	4-4
WLAN access point	
specifications	A-4
WLAN indicator	4-11

Y

Yahsat IP Handset	2-18
-------------------------	------

