



# TAOGLAS®



# Datasheet

## Hinged Cellular Antenna

**Part No:**  
TG.09.0113

### Description

#### Features:

Covering Worldwide 4G-5G Bands between 700-6000MHz  
Rotatable Hinge Design for Optimal reception  
SMA Male Connector as Standard  
CE Certified  
RoHS & Reach Compliant

<b>1.</b>	<b>Introduction</b>	<b>3</b>
<b>2.</b>	<b>Specification</b>	<b>4</b>
<b>3.</b>	<b>Mechanical Drawing</b>	<b>6</b>
<b>4.</b>	<b>Installation Recommendation</b>	<b>7</b>
<b>5.</b>	<b>Packaging</b>	<b>8</b>
<b>6.</b>	<b>Antenna Characteristics</b>	<b>9</b>
<b>7.</b>	<b>Radiation Patterns</b>	<b>13</b>
<hr/>		
	Changelog	78

Taoglas makes no warranties based on the accuracy or completeness of the contents of this document and reserves the right to make changes to specifications and product descriptions at any time without notice. Taoglas reserves all rights to this document and the information contained herein. Reproduction, use or disclosure to third parties without express permission is strictly prohibited.

Ireland & USA  
ISO 9001:2015  
Certified



Taiwan  
ISO 9001:2015  
Certified



# 1. Introduction



The Taoglas TG.09 Terminal Mount Cellular Hinged Rotatable SMA Antenna is a high efficiency monopole antenna. Compared to other much larger antennas on the market, it has superior wide-band high efficiency characteristics over worldwide 4G frequency bands. The TG.09 can also be compatible with some 5G Sub 6GHz cellular bands between 3500-3800MHz.

The unique rotatable hinge design enables the user to rotate the antenna to the best angle to optimize cellular signal reception. As the upper antenna element can move in any direction, it also reduces damage from impact force from any angle to the antenna, compared to traditional hinged right angle or fixed right angle designs or straight antennas.

The small form factor of this antenna, coupled with excellent RF performance and an aesthetic high-end design, make it the ideal cellular antenna for routers, vehicle tracking devices, telematics devices, remote monitoring systems, and POS devices.

The TG.09, as do all monopole antennas, works best when connected directly to the ground-plane of the device main-board. Taoglas offers support services to characterize antenna efficiency on your individual device ground-plane.

The TG.09 antenna also supports LTE 700MHz band applications when it is directly connected to ground-planes with dimensions greater than 60mm.

Please contact your regional Taoglas customer support team if you wish to conduct PTCRB or network approvals with this antenna attached to your device. Taoglas can check that the RF integration is correct and we can also conduct pre-tests to ensure optimized passive and active performance and a smooth and quick certification approval process.

The TG.09 is also available with a white enclosure- TG.09.0113W.

## 2. Specification

Electrical									
Band	Frequency (MHz)	Measurement	Efficiency (%)	Average Gain (dB)	Peak Gain (dBi)	Impedance	Polarization	Radiation Pattern	Max. input power
5G NR/4G Band 71	617-698	15x9cm Ground Plane (Bent)	37.9	-4.21	1.32	50 Ω	Linear	Omni directional	10W
		15x9cm Ground Plane (Straight)	55.0	-2.60	2.30				
		30x30cm Ground Plane Center (Bent)	3.8	-14.18	-9.15				
		30x30cm Ground Plane Center (Straight)	11.9	-9.25	-4.58				
		30x30cm Ground Plane Edge (Bent)	15.8	-8.02	-1.08				
		30x30cm Ground Plane Edge (Straight)	26.6	-5.76	0.08				
		Free Space (Bent)	18.2	-7.40	-0.52				
Free Space (Straight)	21.5	-6.68	0.78						
4G/3G Band 12,13,14,17,28,29	698-806	15x9cm Ground Plane (Bent)	68.1	-1.67	2.85	50 Ω	Linear	Omni directional	10W
		15x9cm Ground Plane (Straight)	76.4	-1.17	2.85				
		30x30cm Ground Plane Center (Bent)	13.9	-8.57	-1.89				
		30x30cm Ground Plane Center (Straight)	43.0	-3.67	1.50				
		30x30cm Ground Plane Edge (Bent)	47.3	-3.25	2.88				
		30x30cm Ground Plane Edge (Straight)	64.7	-1.89	2.69				
		Free Space (Bent)	41.1	-3.86	1.71				
Free Space (Straight)	46.2	-3.36	2.48						
4G/3G/NB-IoT/Cat M Band 5,8,18,19,20,26,27	824-960	15x9cm Ground Plane (Bent)	72.4	-1.40	2.73	50 Ω	Linear	Omni directional	10W
		15x9cm Ground Plane (Straight)	63.7	-1.96	2.20				
		30x30cm Ground Plane Center (Bent)	40.1	-3.97	2.06				
		30x30cm Ground Plane Center (Straight)	74.0	-1.31	3.37				
		30x30cm Ground Plane Edge (Bent)	82.6	-0.83	3.16				
		30x30cm Ground Plane Edge (Straight)	80.5	-0.94	2.58				
		Free Space (Bent)	52.0	-2.84	2.77				
Free Space (Straight)	50.6	-2.95	3.06						
5G NR/4G Band 21,32,74,75,76	1427-1518	15x9cm Ground Plane (Bent)	38.4	-4.15	1.52	50 Ω	Linear	Omni directional	10W
		15x9cm Ground Plane (Straight)	42.0	-3.76	1.54				
		30x30cm Ground Plane Center (Bent)	16.4	-7.86	-2.21				
		30x30cm Ground Plane Center (Straight)	7.2	-11.40	-3.71				
		30x30cm Ground Plane Edge (Bent)	17.0	-7.71	-0.48				
		30x30cm Ground Plane Edge (Straight)	15.8	-8.01	-1.07				
		Free Space (Bent)	20.2	-6.94	-1.24				
Free Space (Straight)	18.6	-7.31	-2.18						
4G/3G Band 1,2,3,4,9,23,25,35,39,66	1710-2200	15x9cm Ground Plane (Bent)	73.0	-1.37	4.21	50 Ω	Linear	Omni directional	10W
		15x9cm Ground Plane (Straight)	72.3	-1.41	4.06				
		30x30cm Ground Plane Center (Bent)	74.1	-1.30	4.14				
		30x30cm Ground Plane Center (Straight)	75.1	-1.24	4.14				
		30x30cm Ground Plane Edge (Bent)	74.9	-1.25	3.87				
		30x30cm Ground Plane Edge (Straight)	80.1	-0.96	3.95				
		Free Space (Bent)	54.3	-2.65	3.92				
Free Space (Straight)	56.2	-2.50	4.27						
4G/3G Band 7,30,38,40,41	2300-2690	15x9cm Ground Plane (Bent)	54.1	-2.67	3.25	50 Ω	Linear	Omni directional	10W
		15x9cm Ground Plane (Straight)	52.2	-2.83	2.99				
		30x30cm Ground Plane Center (Bent)	54.3	-2.65	4.14				
		30x30cm Ground Plane Center (Straight)	49.0	-3.10	3.49				
		30x30cm Ground Plane Edge (Bent)	57.1	-2.43	3.91				
		30x30cm Ground Plane Edge (Straight)	53.1	-2.75	3.25				
		Free Space (Bent)	46.0	-3.37	2.53				
Free Space (Straight)	45.0	-3.46	2.37						
5G NR/4G Band 22,42,48,77,78,79	3300-5000	15x9cm Ground Plane (Bent)	53.1	-2.75	4.91	50 Ω	Linear	Omni directional	10W
		15x9cm Ground Plane (Straight)	49.4	-3.06	4.18				
		30x30cm Ground Plane Center (Bent)	67.6	-1.70	4.99				
		30x30cm Ground Plane Center (Straight)	63.4	-1.98	4.79				

		30x30cm Ground Plane Edge (Bent)	75.6	-1.22	6.04				
		30x30cm Ground Plane Edge (Straight)	67.5	-1.71	4.89				
		Free Space (Bent)	61.4	-2.12	4.10				
		Free Space (Straight)	58.0	-2.37	4.19				
LTE5200/Wi-Fi5800	5150-5925	15x9cm Ground Plane (Bent)	37.9	-4.22	2.80				
		15x9cm Ground Plane (Straight)	28.2	-5.50	1.09				
		30x30cm Ground Plane Center (Bent)	46.1	-3.36	3.71				
		30x30cm Ground Plane Center (Straight)	48.0	-3.19	3.82				
		30x30cm Ground Plane Edge (Bent)	54.3	-2.66	4.29				
		30x30cm Ground Plane Edge (Straight)	49.0	-3.10	3.32				
		Free Space (Bent)	46.0	-3.38	3.13				
		Free Space (Straight)	34.4	-4.64	2.32				

### Mechanical

Dimensions	Ø10 x 72mm
Casing	POM
Connector	SMA Male Hinged
Weight	8g

### Environmental

Operation Temperature	-40°C to +85°C
Storage Temperature	-40°C to +85°C
Relative Humidity	Non-condensing 65°C 95% RH

### 3. Mechanical Drawing

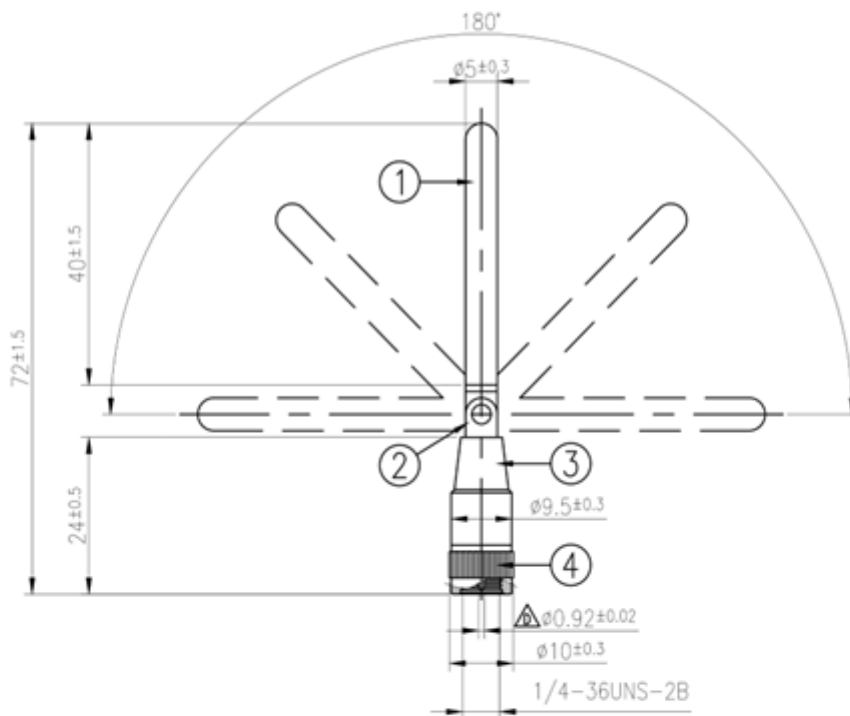
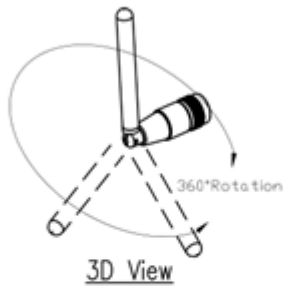

	Name	P/N	Material	Finish	QTY
1	Housing	000611G000002A	POM	Black	1
2	Hinge	210211G040002A	Brass	Ni Plated	1
3	Cap	000613C010002A	POM	Black	1
4	SMA(M)ST	210213C010002A	Brass	Ni Plated	1

## 4. Installation Recommendation

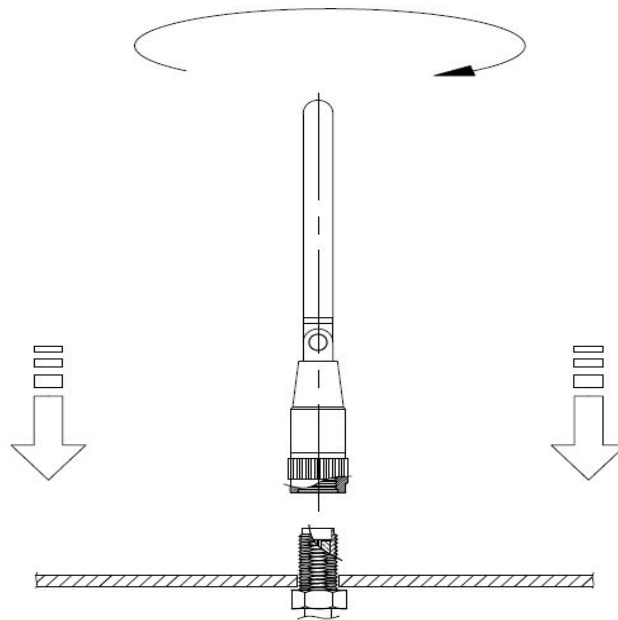

Hand tighten only, Do not use antenna as a lever.

## 5. Packaging

1 pcs TG.09.0113 per PE bag  
 PE Bag Dimensions - 74 x 42mm  
 Weight - 8.6g

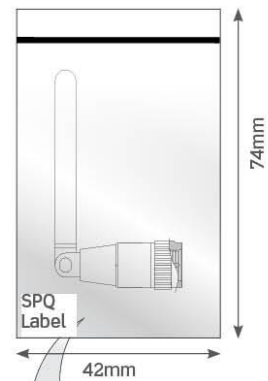

100 pcs TG.09.0113 per large PE bags  
 Large PE bags Dimensions - 280 x 180mm  
 Weight - 0.88kg

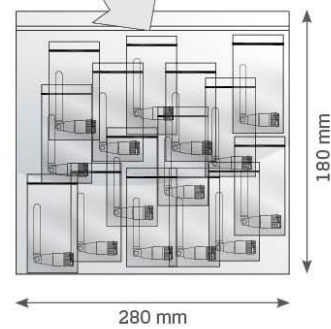

1500 pcs TG.09.0113 per carton  
 Carton Dimensions - 360 x 310 x 160mm  
 Weight - 13.5kg

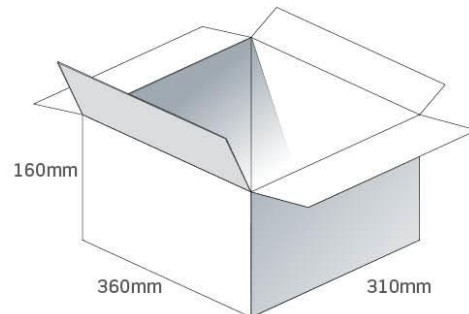

Pallet Dimensions 1200\*1000\*1480mm  
 72 Cartons per Pallet  
 9 Cartons per layer  
 8 Layers

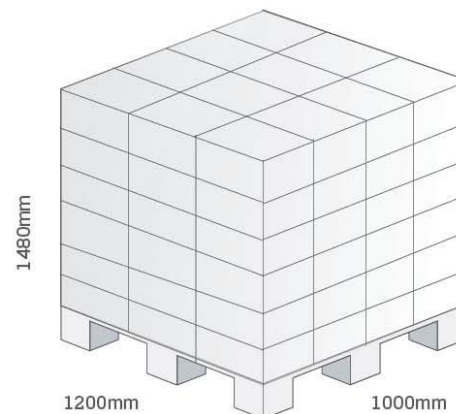



# 6. Antenna Characteristics

## 6.1 Test Setup

AUT



Vector Network Analyzer

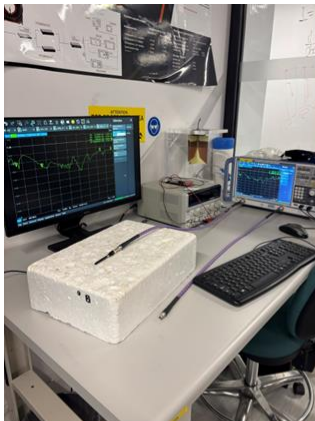

Free Space- Straight

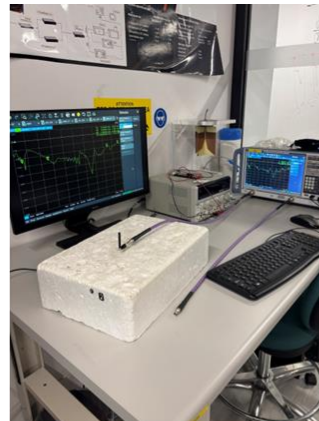

Free Space- Bent

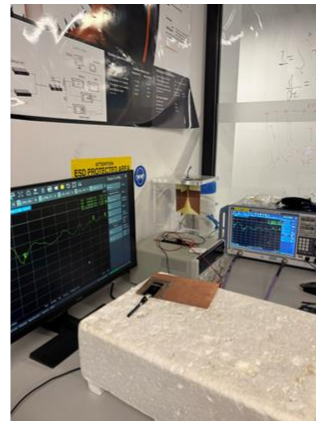

15x9cm Ground Plane  
Straight

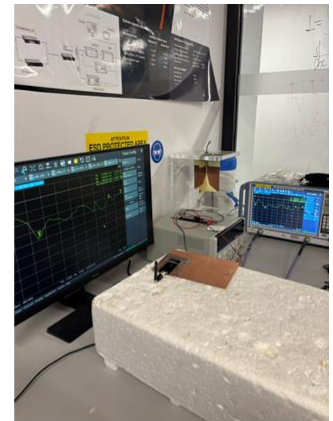

15x9cm Ground Plane  
Bent

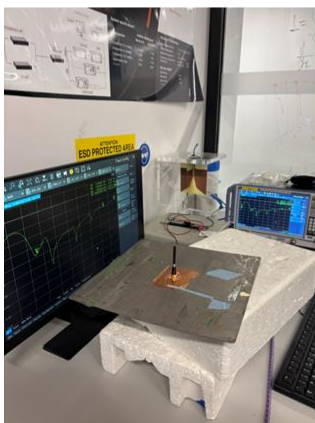

30x30cm Ground Plane  
(Centre) Straight

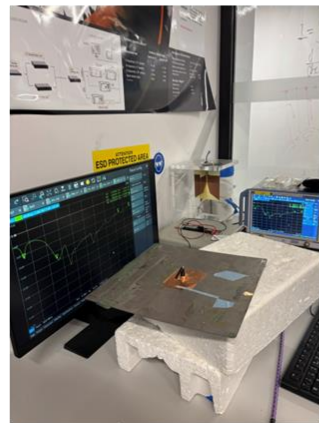

30x30cm Ground Plane  
(Centre) Bent

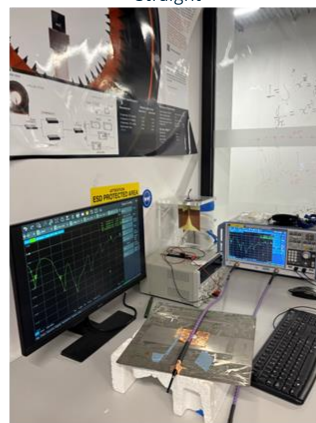

30x30cm Ground Plane  
(Edge) Straight

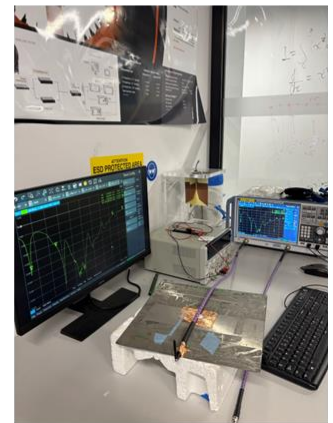

30x30cm Ground Plane  
(Edge) Bent

## 6.2 Return Loss

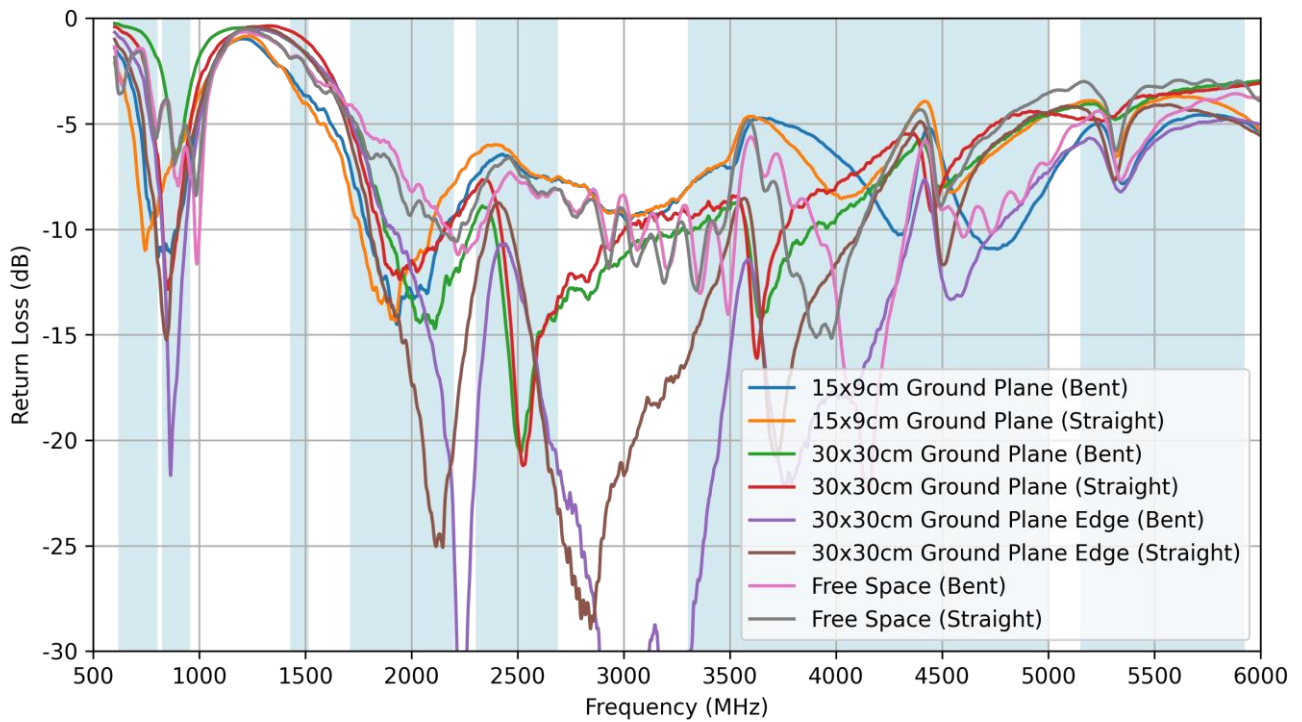

## 6.3 VSWR

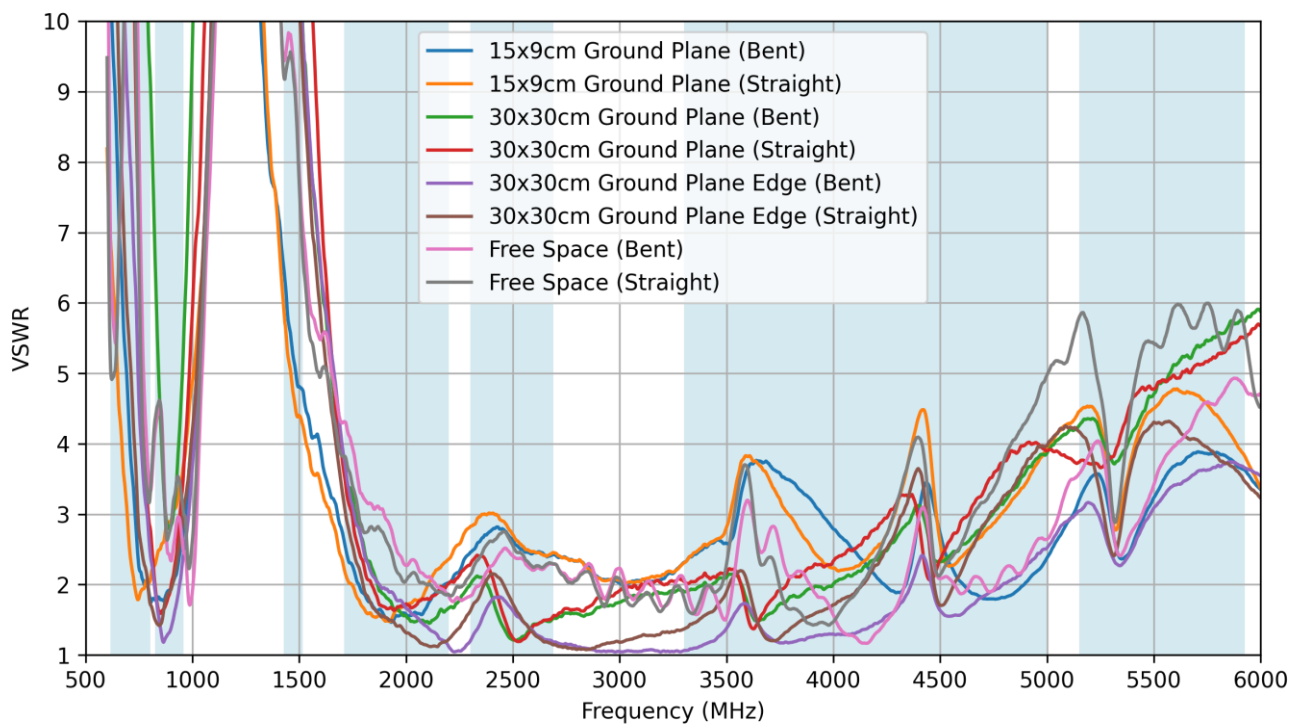

## 6.4 Efficiency

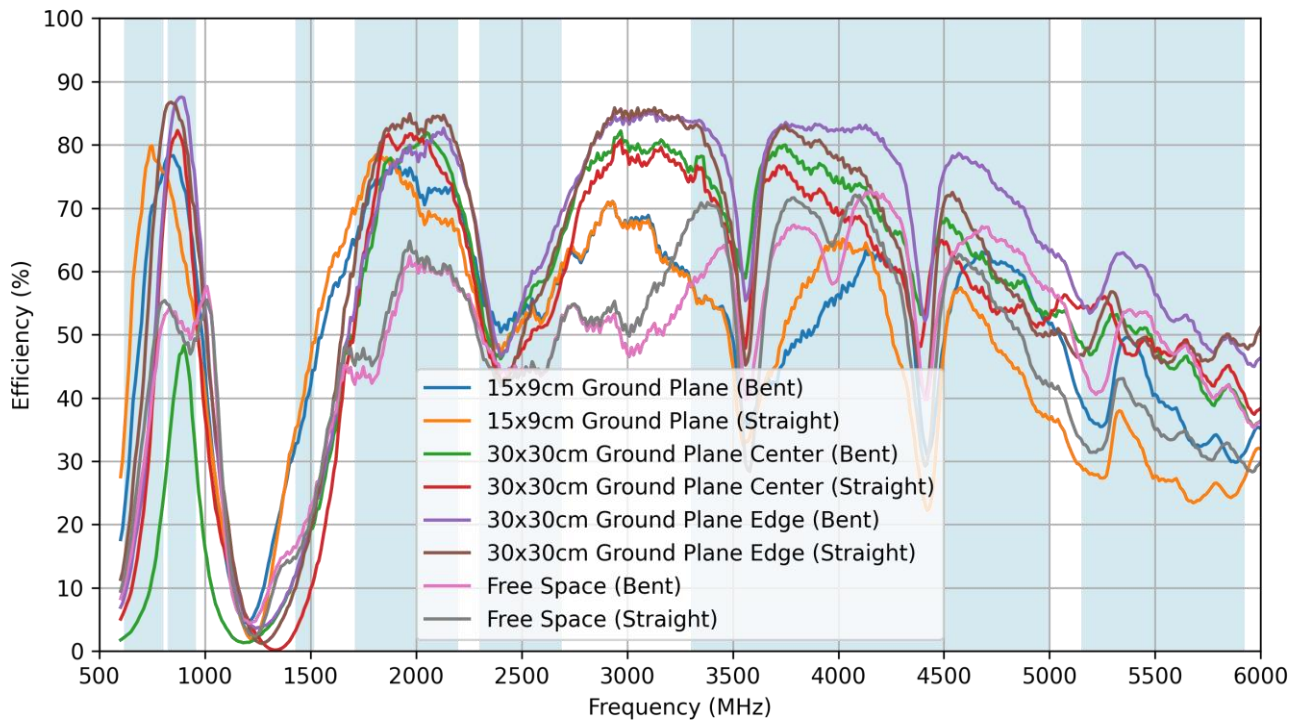

## 6.5 Average Gain

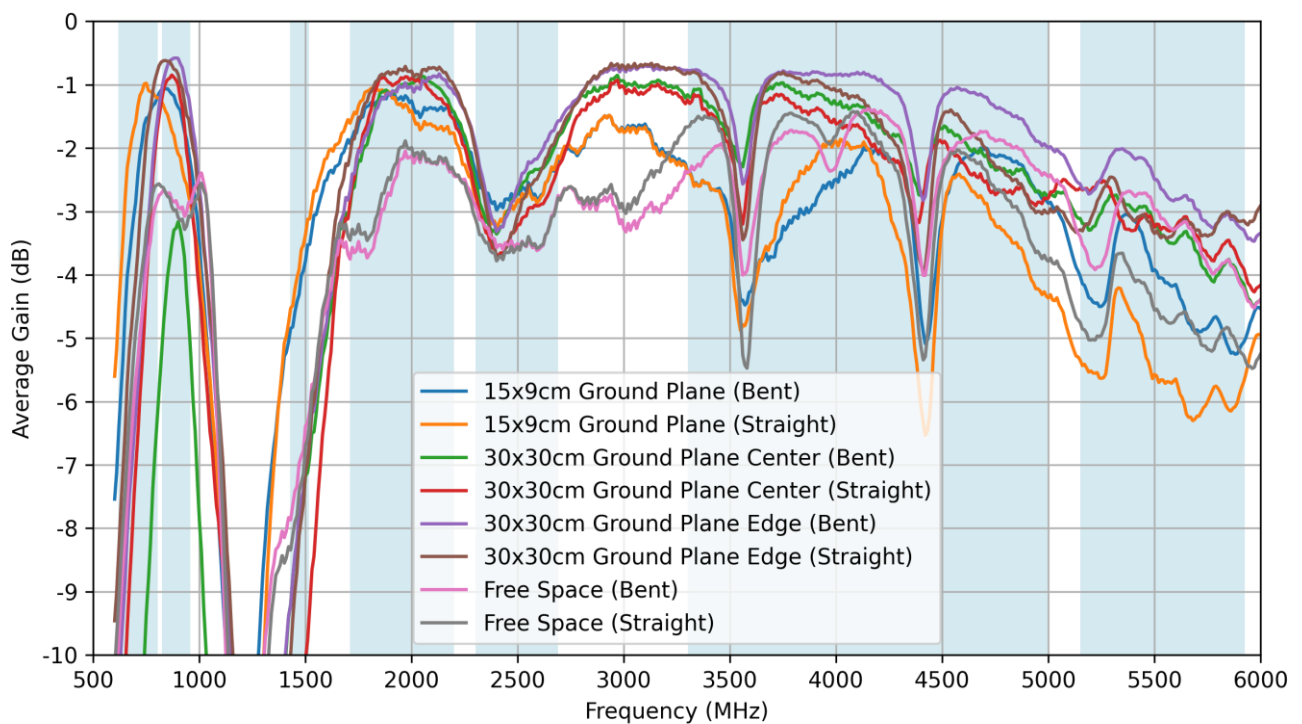

## 6.6 Peak Gain

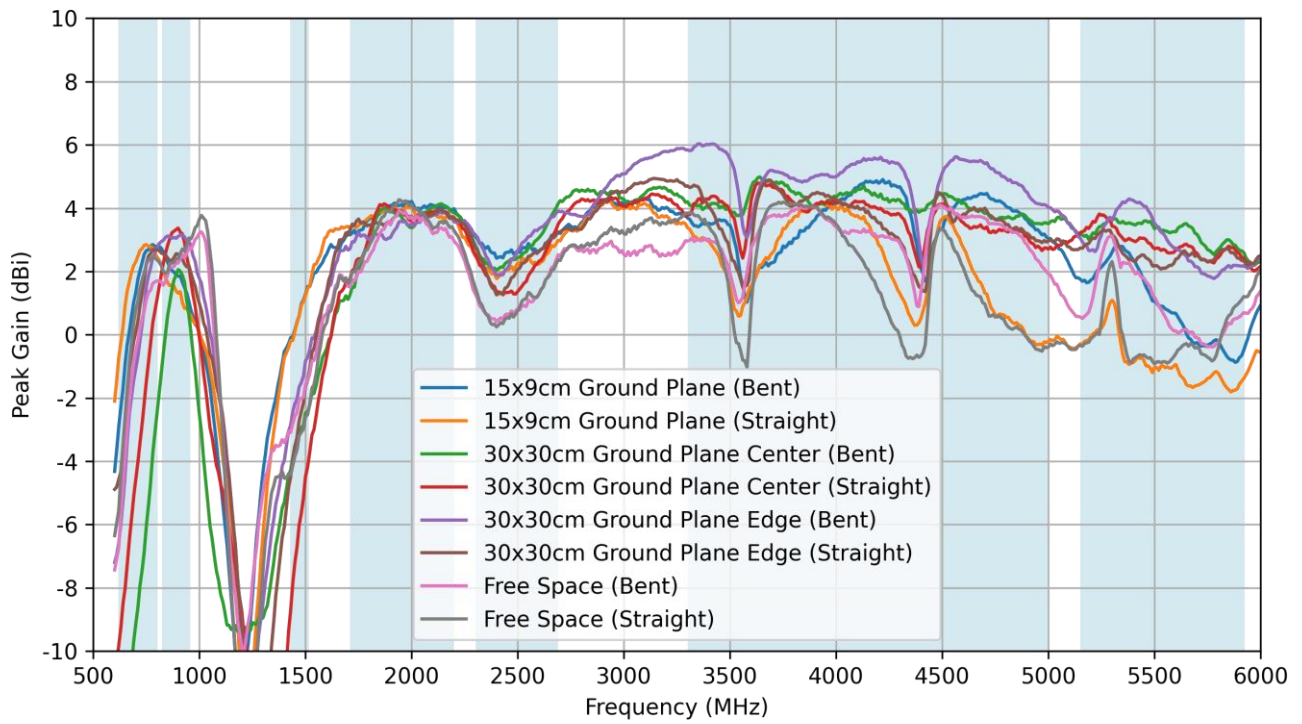

# 7. Radiation Patterns

## 7.1 Test Setup

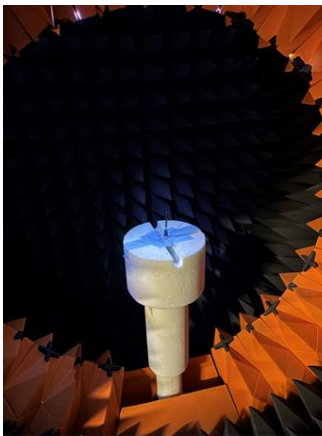
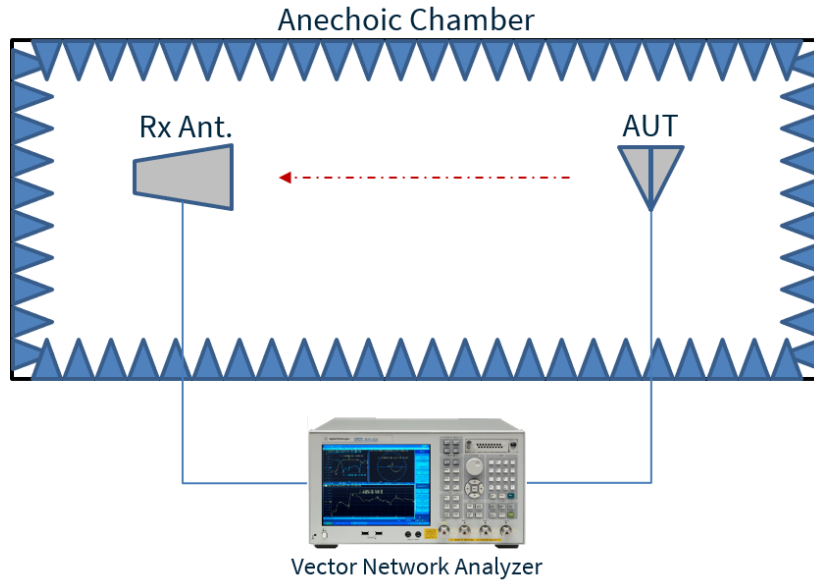

Free Space- Straight

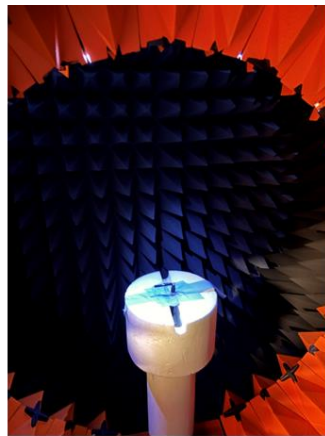

Free Space- Bent

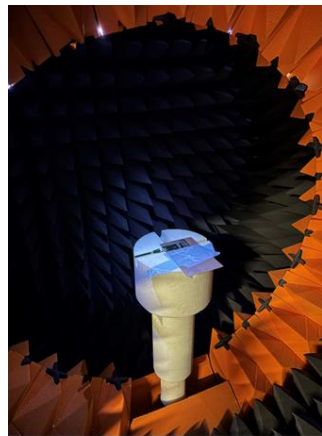

15x9cm Ground Plane  
Straight



15x9cm Ground Plane  
Bent

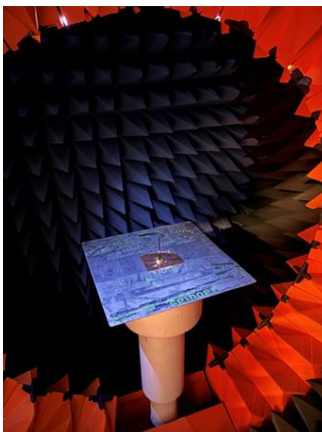

30x30cm Ground Plane  
(Centre) Straight

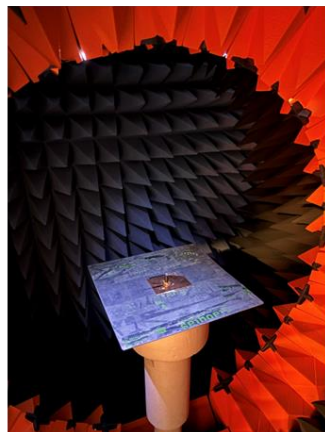

30x30cm Ground Plane  
(Centre) Bent

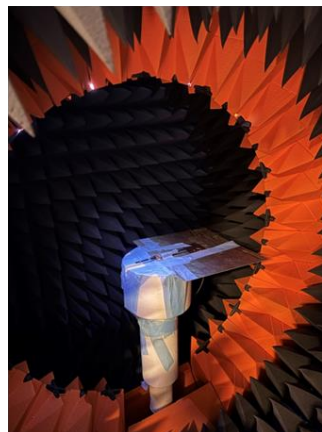

30x30cm Ground Plane  
(Edge) Straight

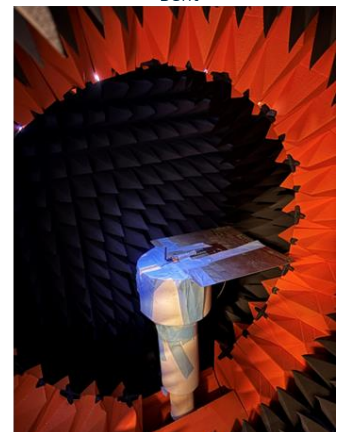

30x30cm Ground Plane  
(Edge) Bent

7.2 15x9cm Ground Plane (Bent) Patterns at 660 MHz

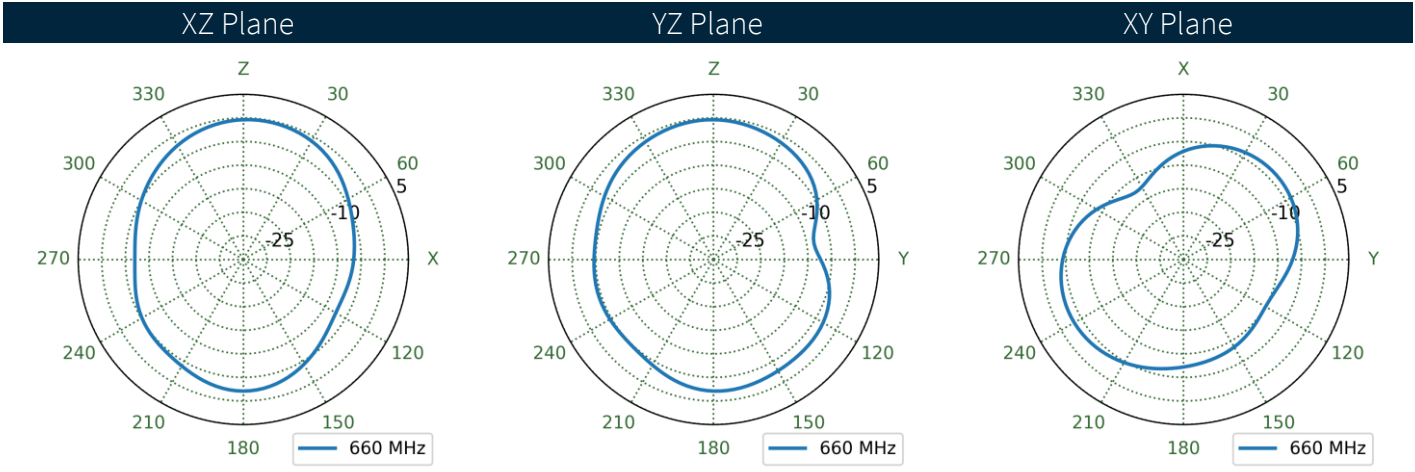
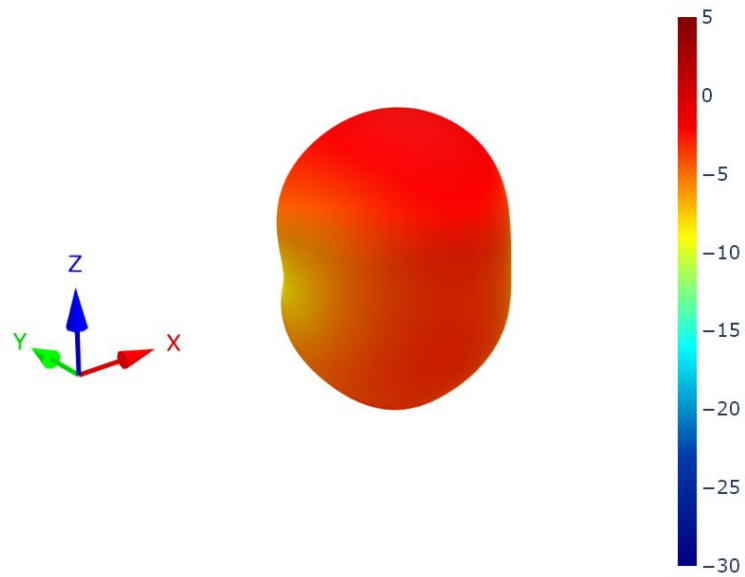

7.3 15x9cm Ground Plane (Straight) Patterns at 660 MHz

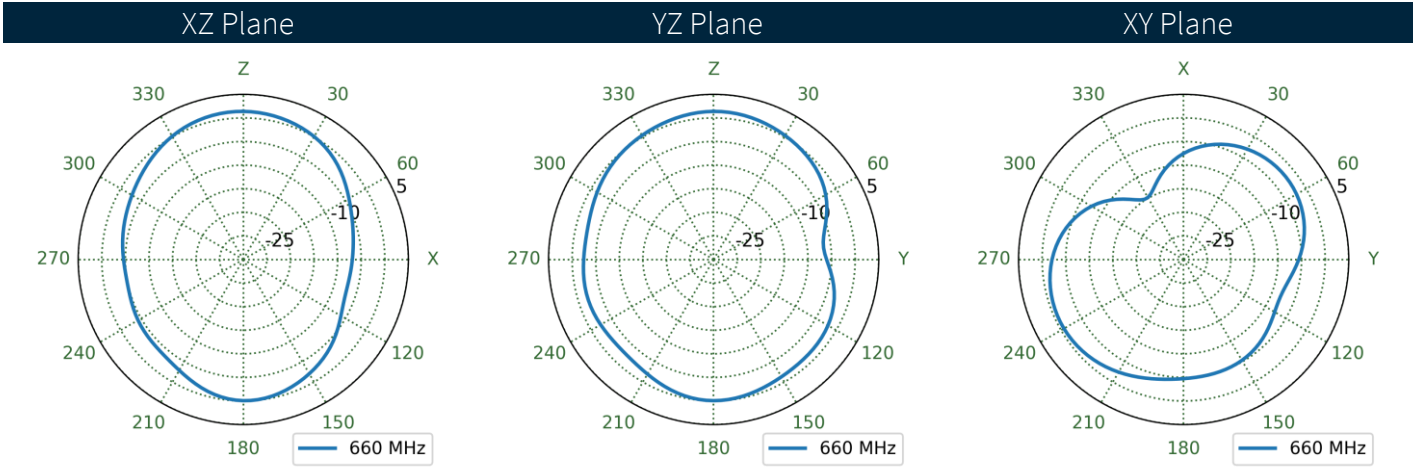
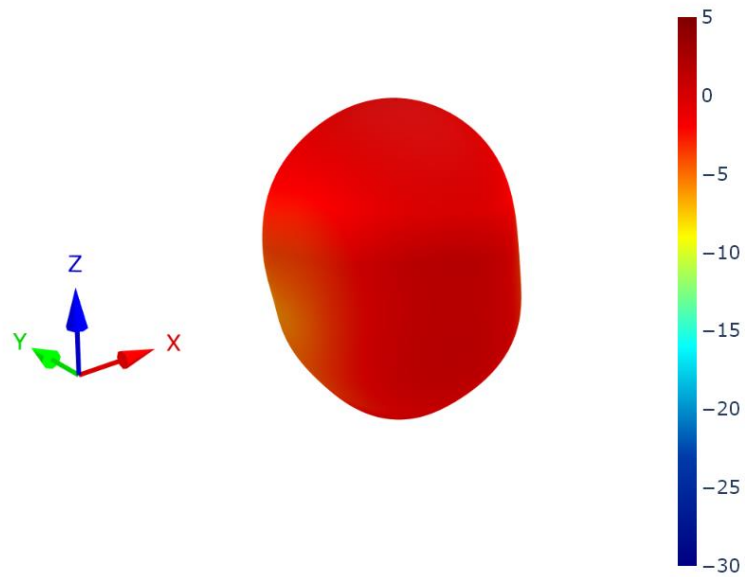

7.4 30x30cm Ground Plane Center (Bent) Patterns at 660 MHz

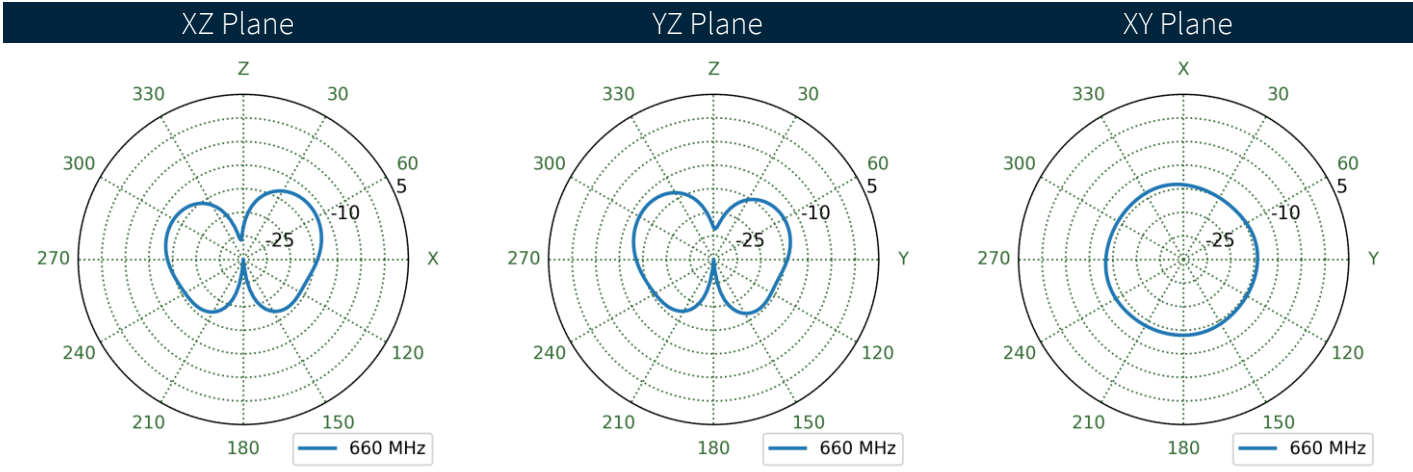
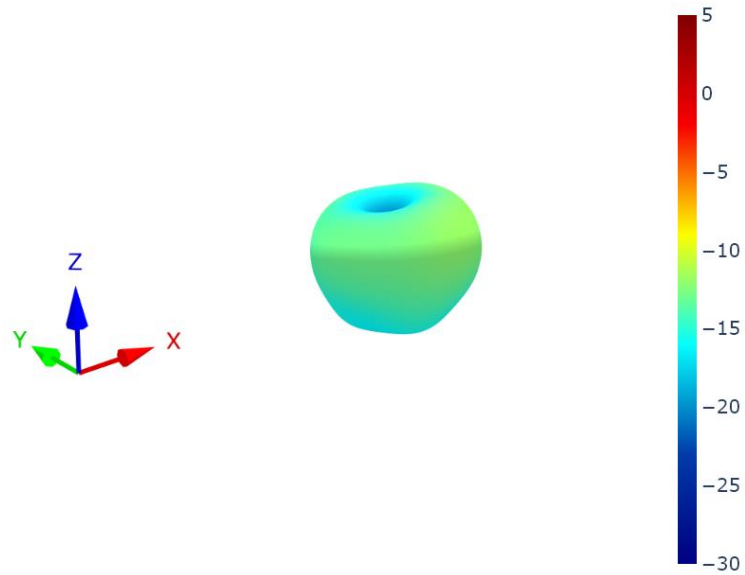



7.5 30x30cm Ground Plane Center (Straight) Patterns at 660 MHz

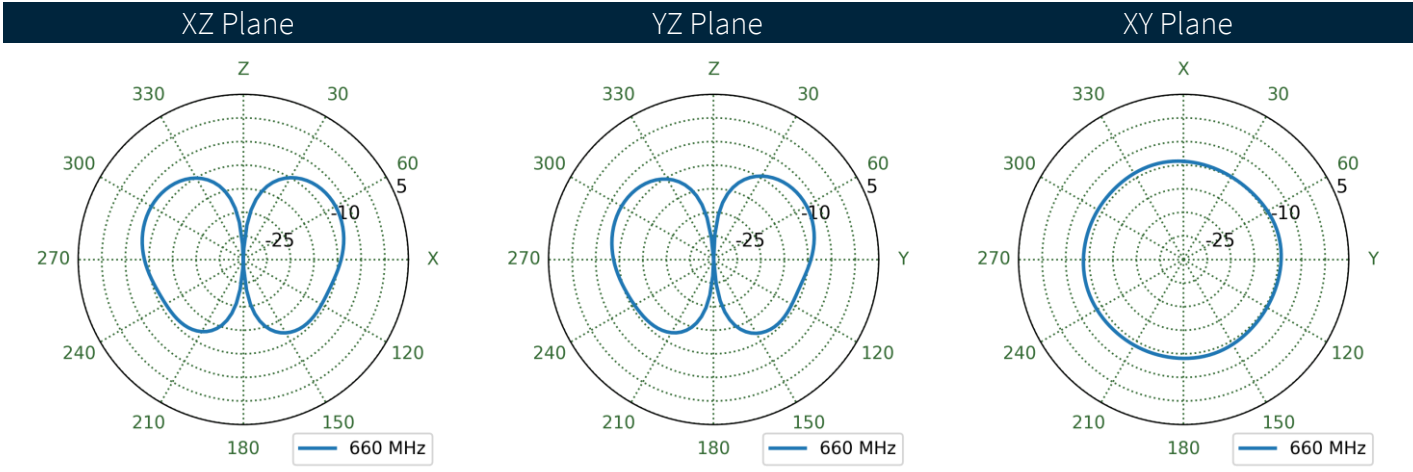
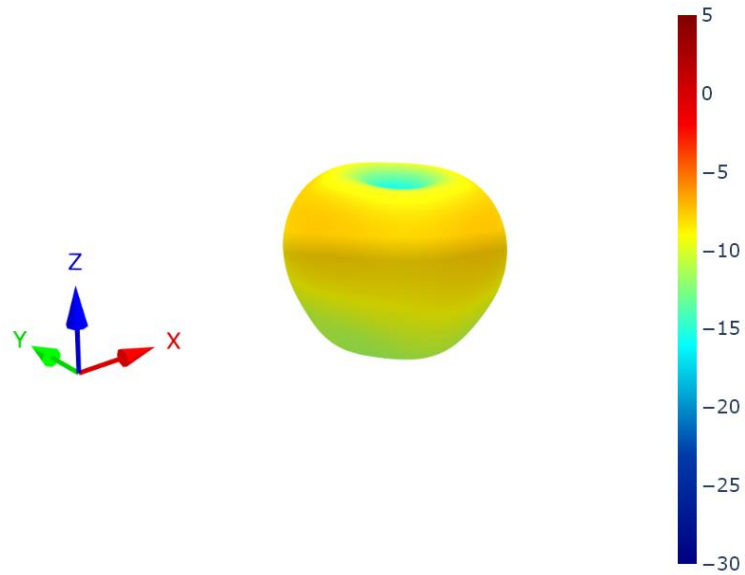

7.6 30x30cm Ground Plane Edge (Bent) Patterns at 660 MHz

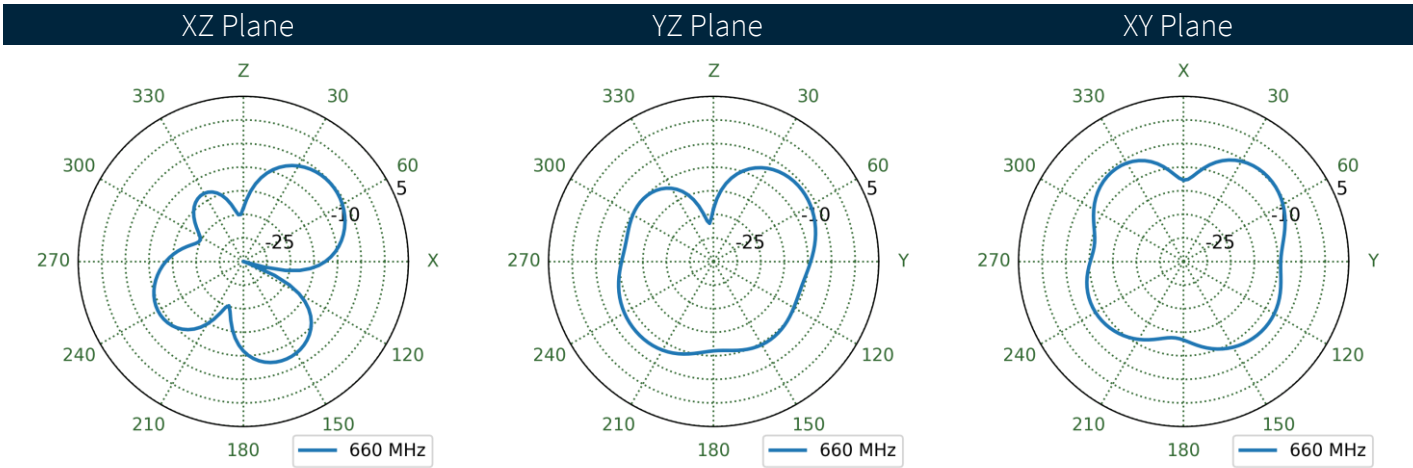
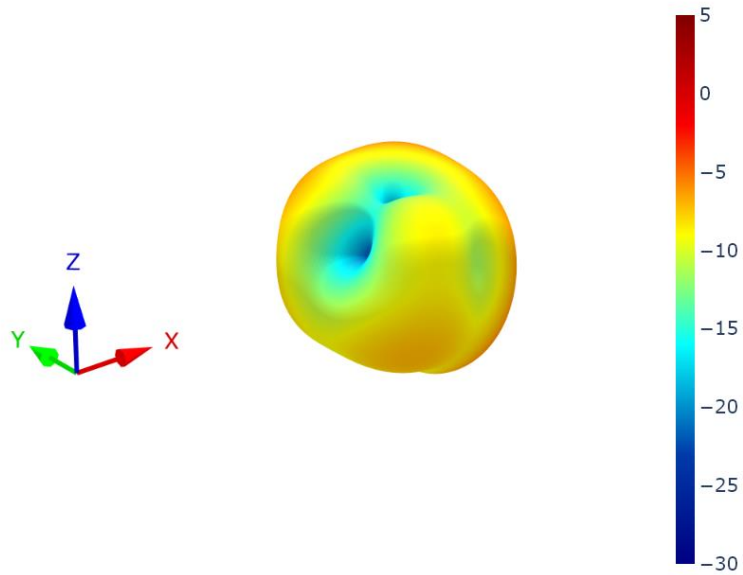

7.7 30x30cm Ground Plane Edge (Straight) Patterns at 660 MHz

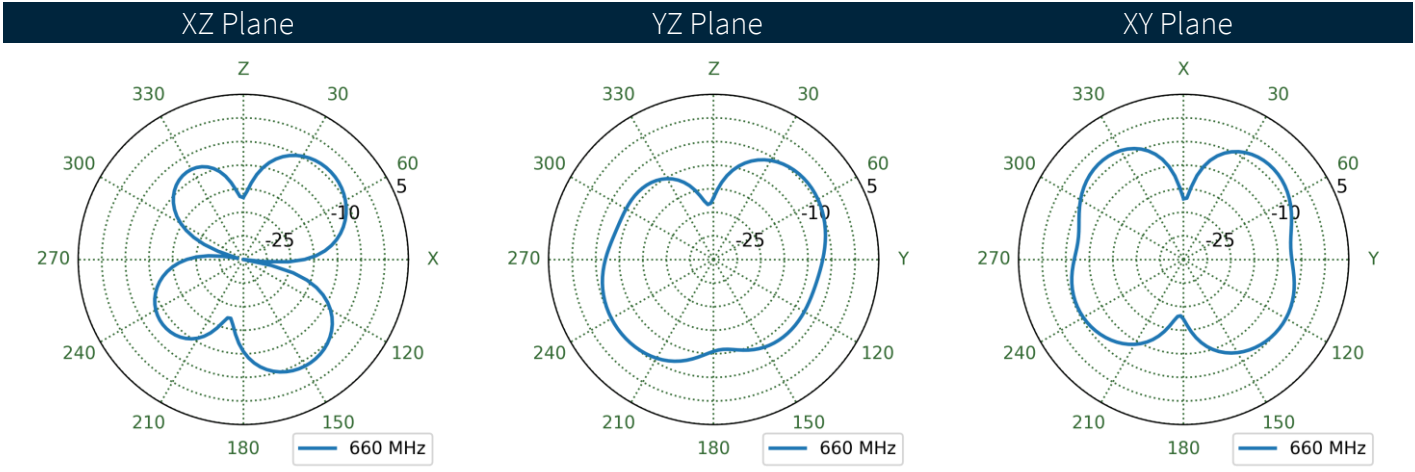
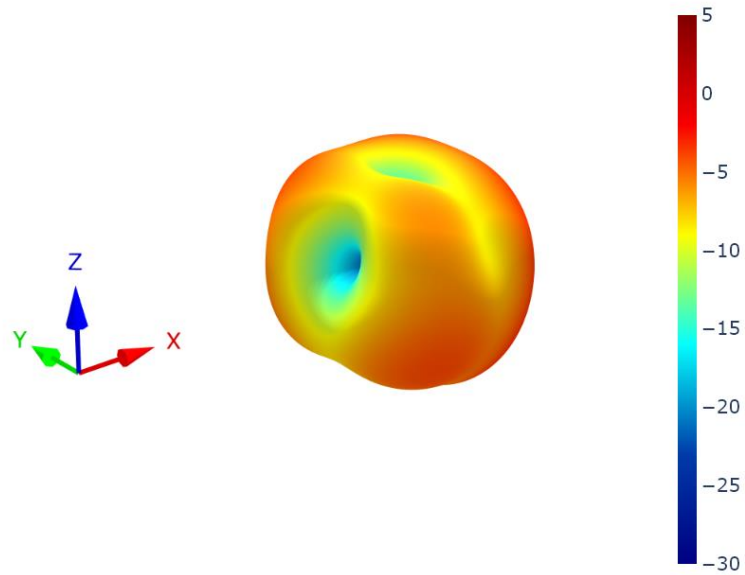

7.8 Free Space (Bent) Patterns at 660 MHz

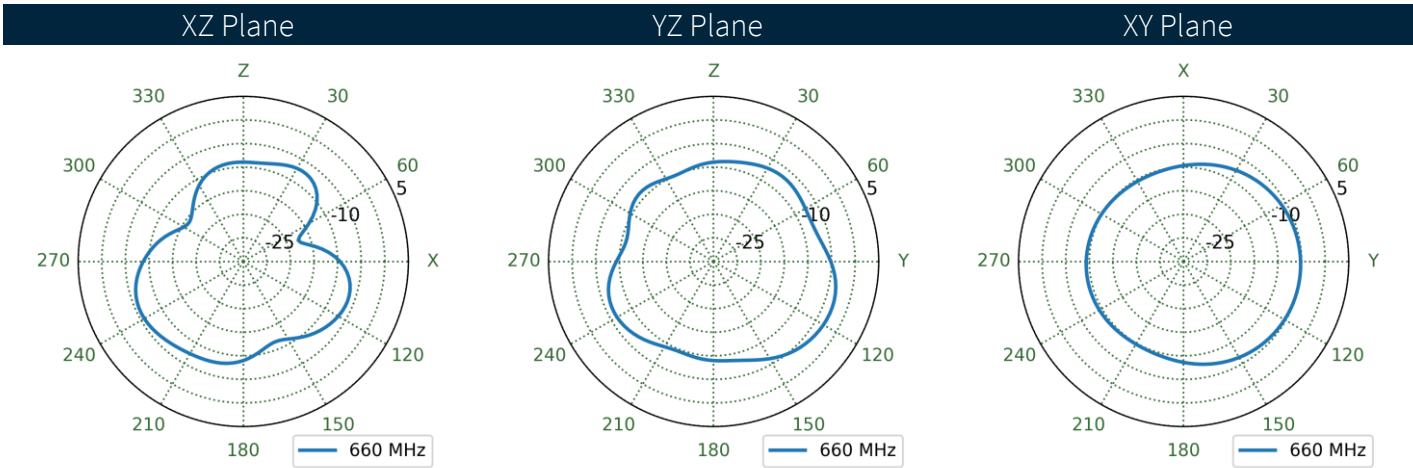
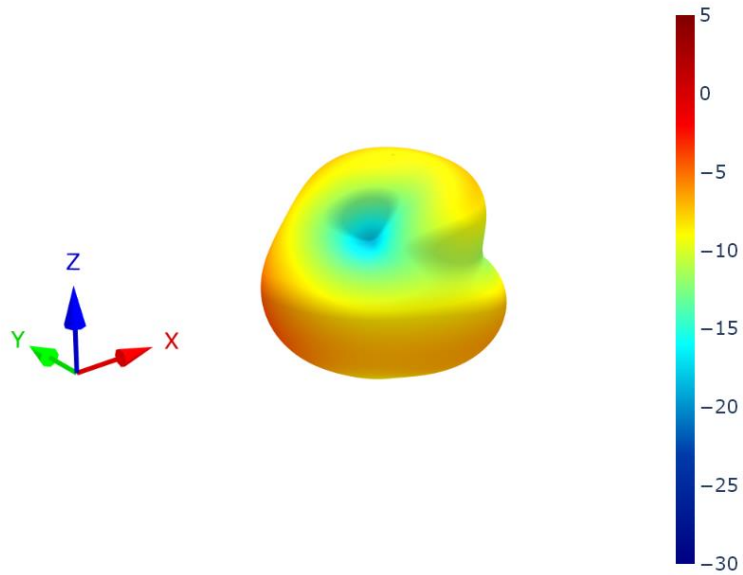

7.9 Free Space (Straight) Patterns at 660 MHz

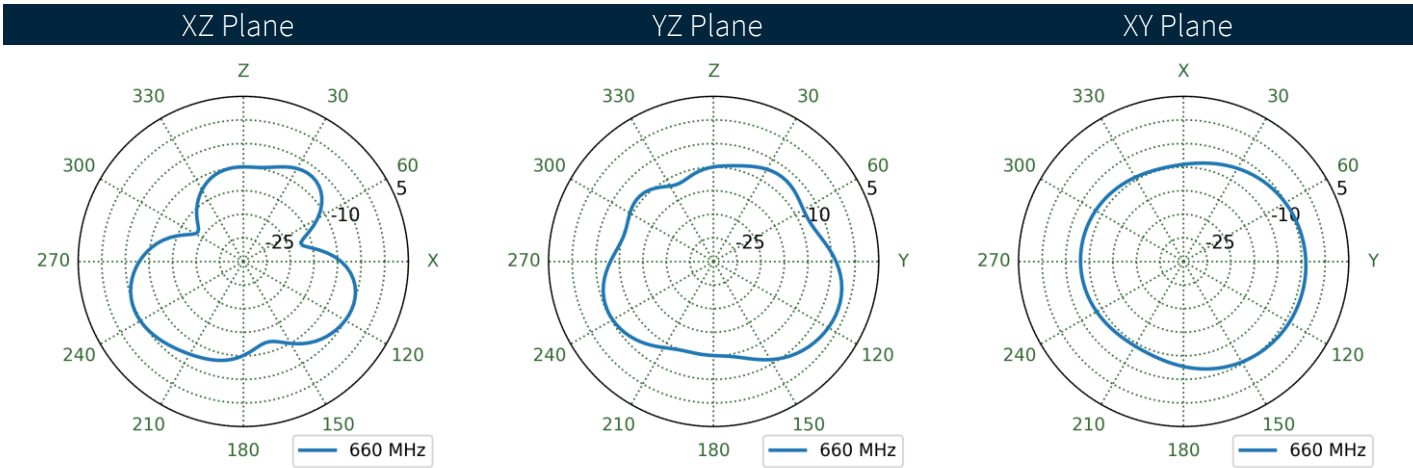
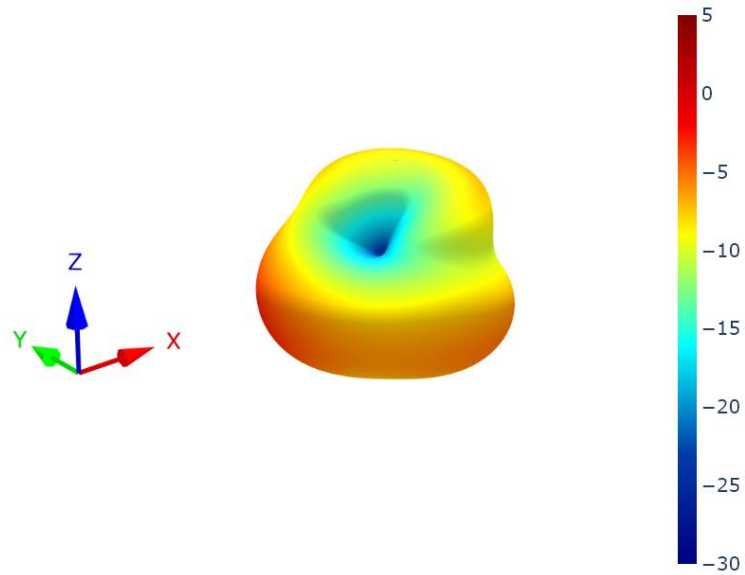

**7.10** 15x9cm Ground Plane (Bent) Patterns at 750 MHz

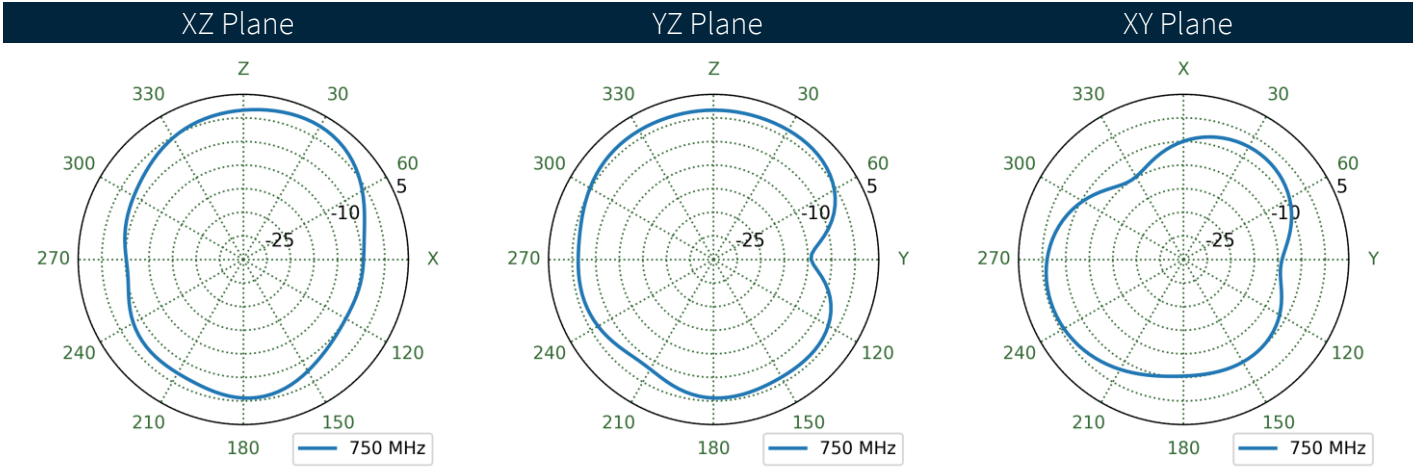
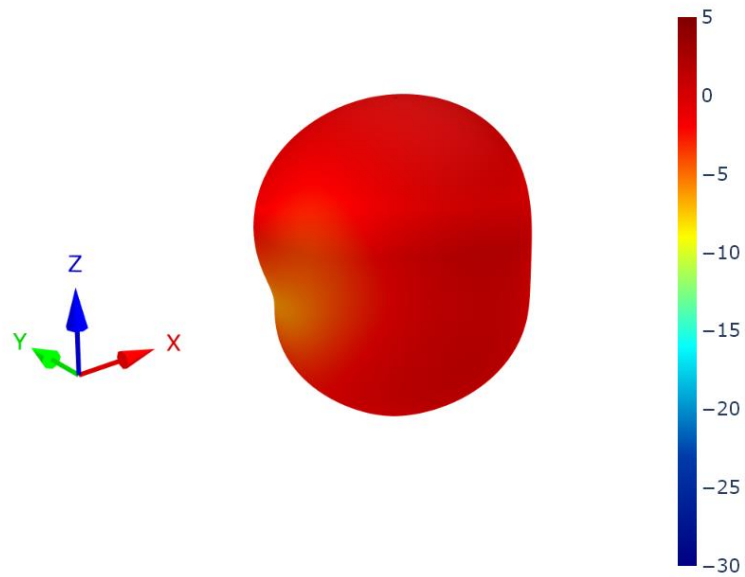

7.11 15x9cm Ground Plane (Straight) Patterns at 750 MHz

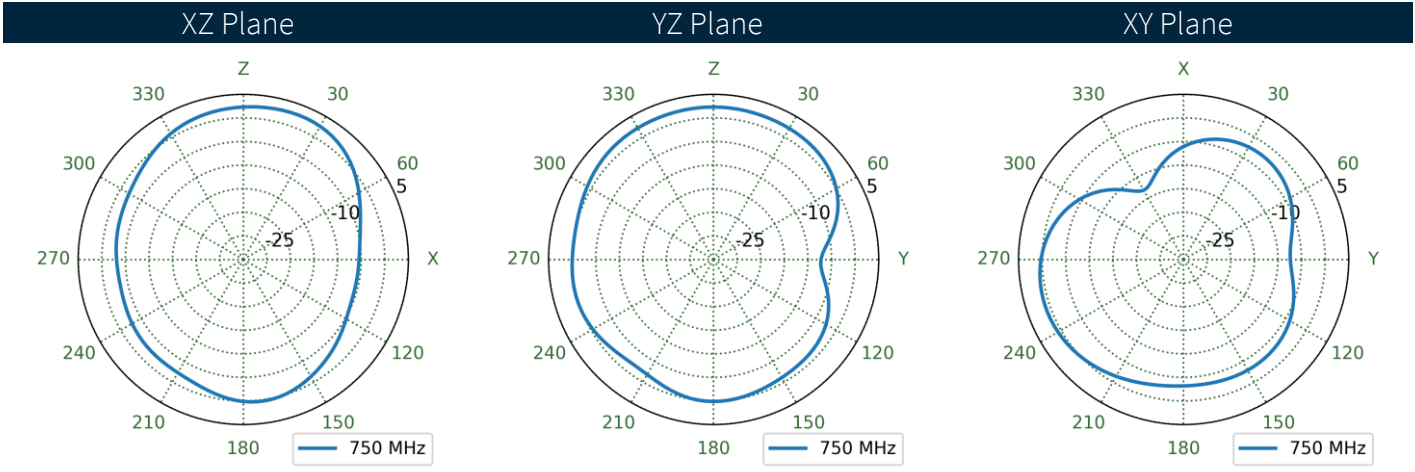
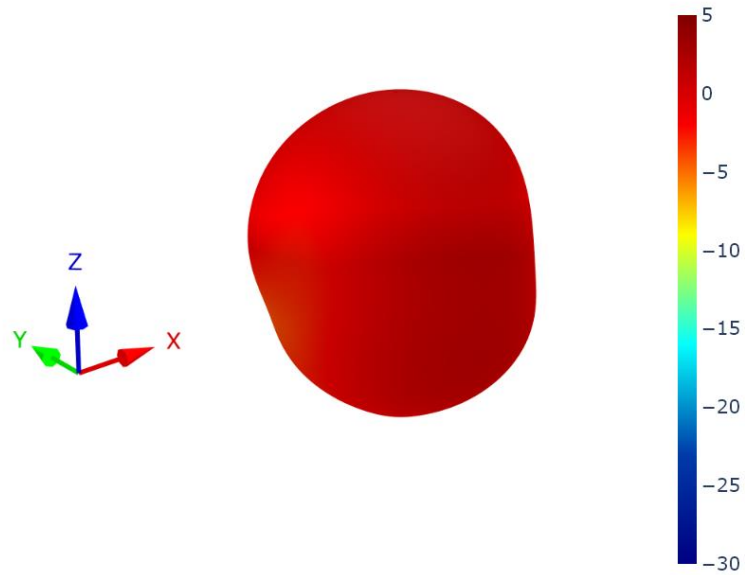

7.12 30x30cm Ground Plane Center (Bent) Patterns at 750 MHz

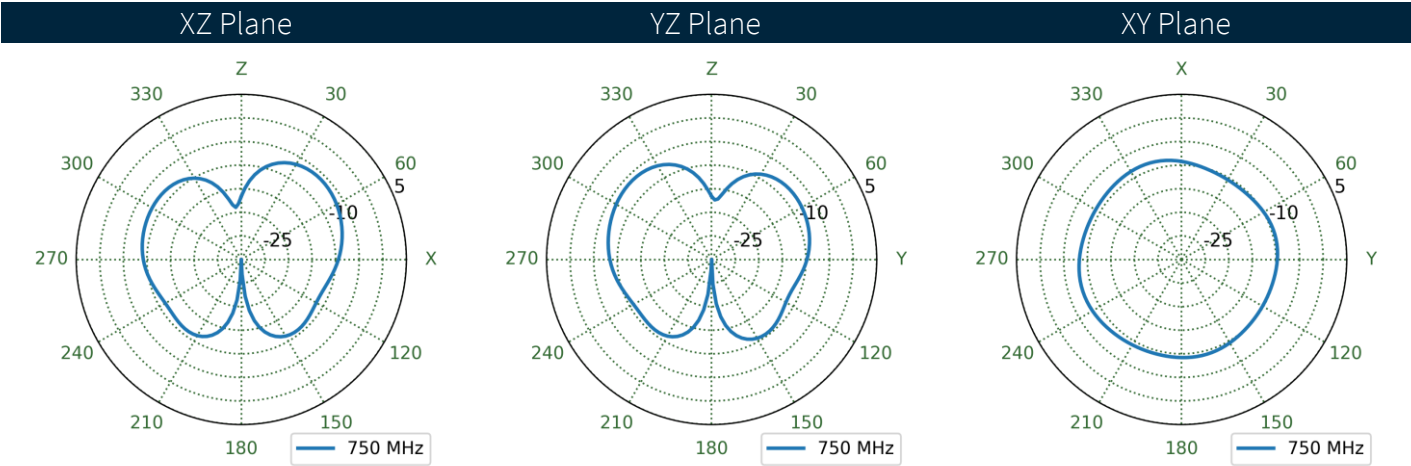
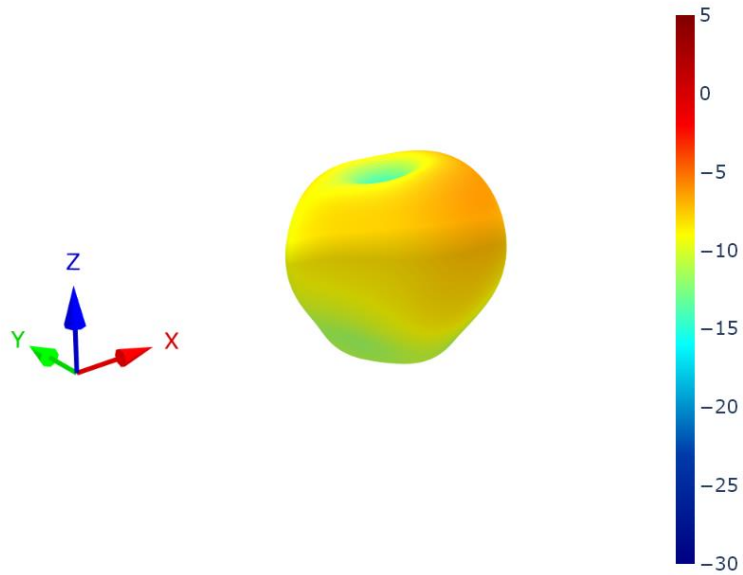



7.13 30x30cm Ground Plane Center (Straight) Patterns at 750 MHz

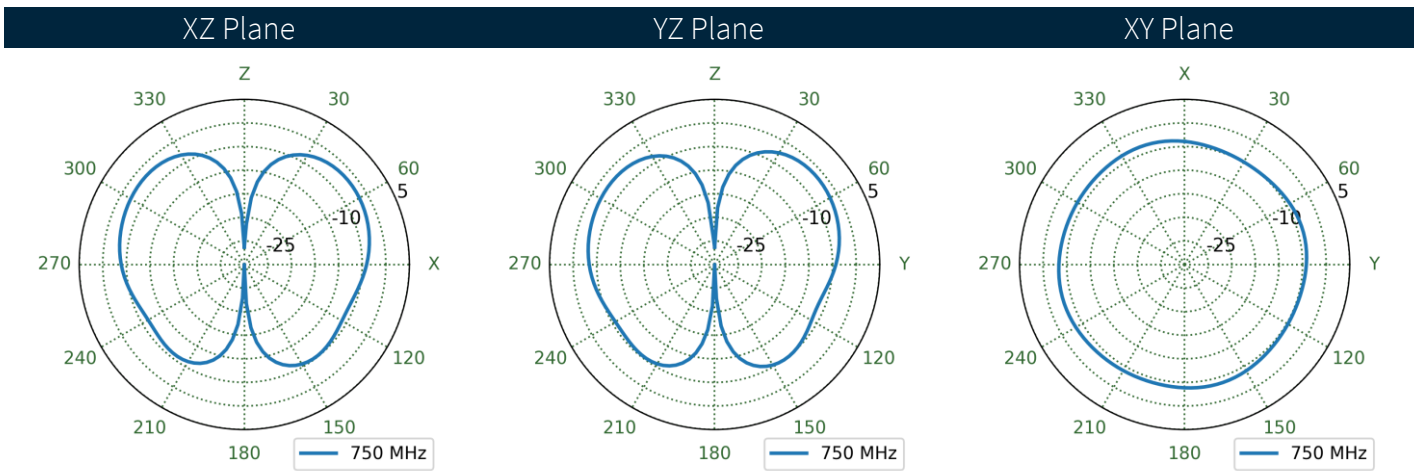
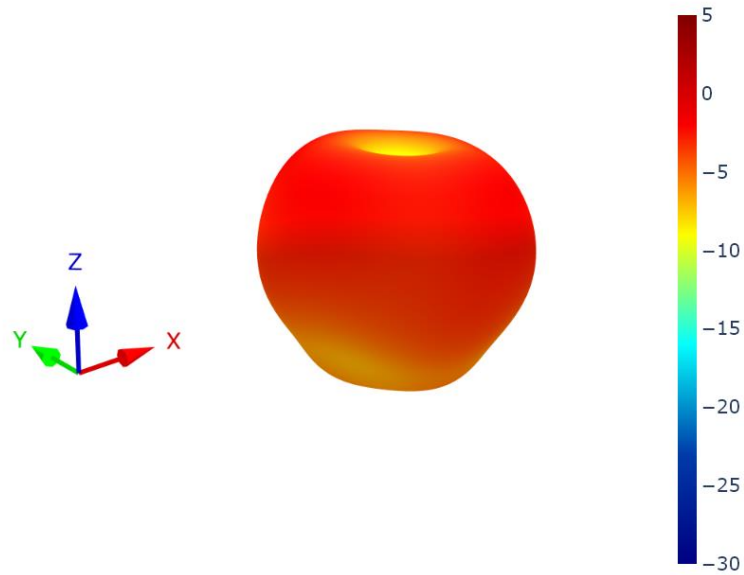

7.14 30x30cm Ground Plane Edge (Bent) Patterns at 750 MHz

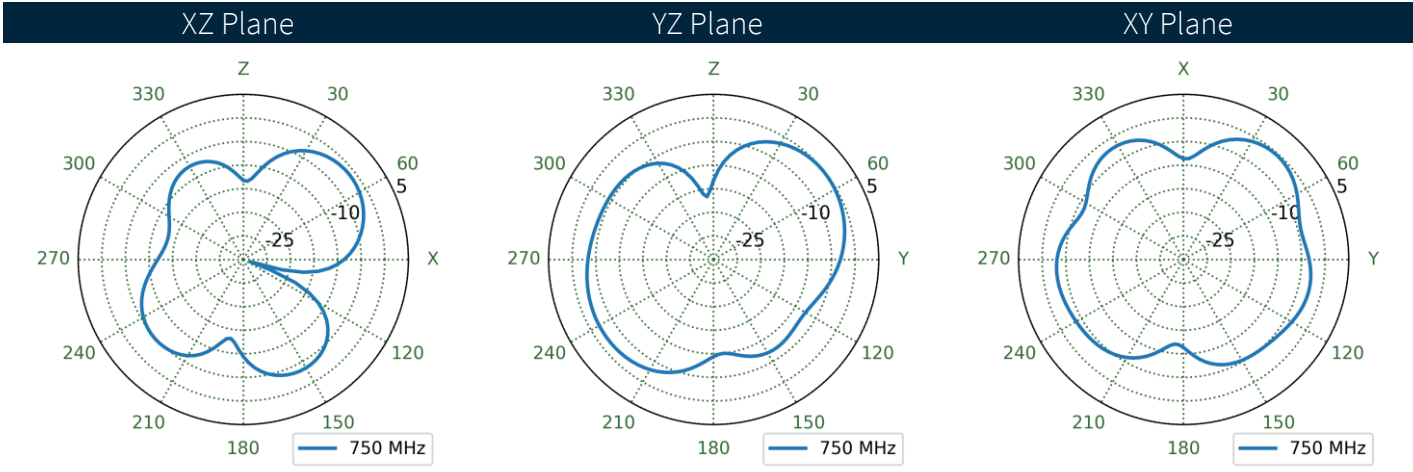
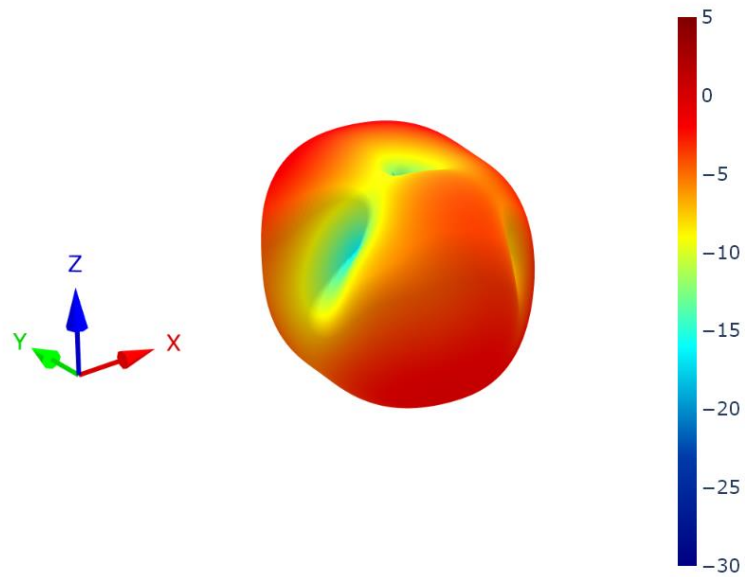

7.15 30x30cm Ground Plane Edge (Straight) Patterns at 750 MHz

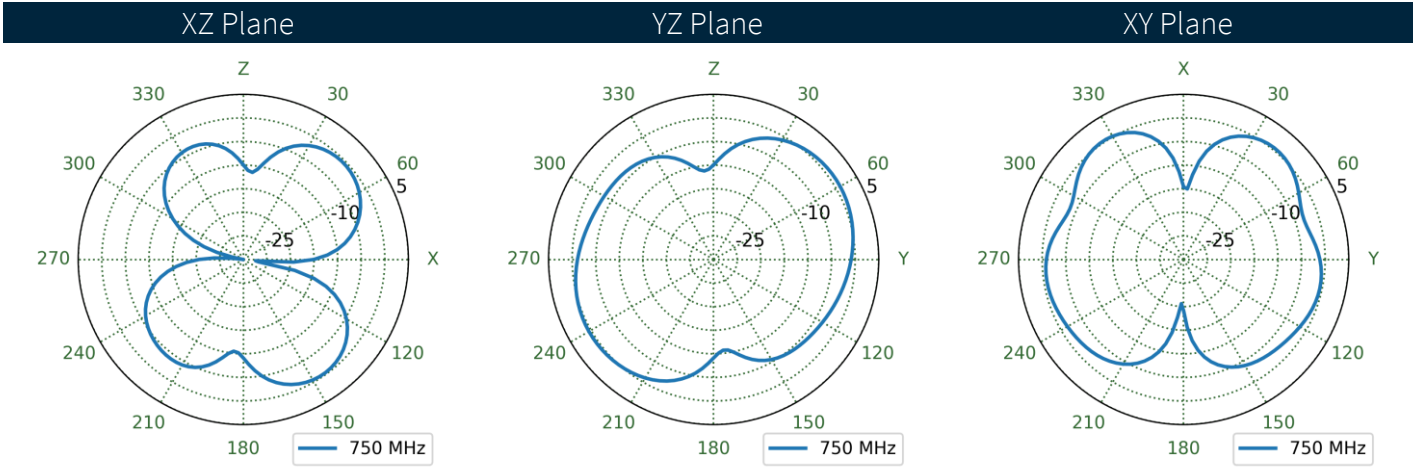
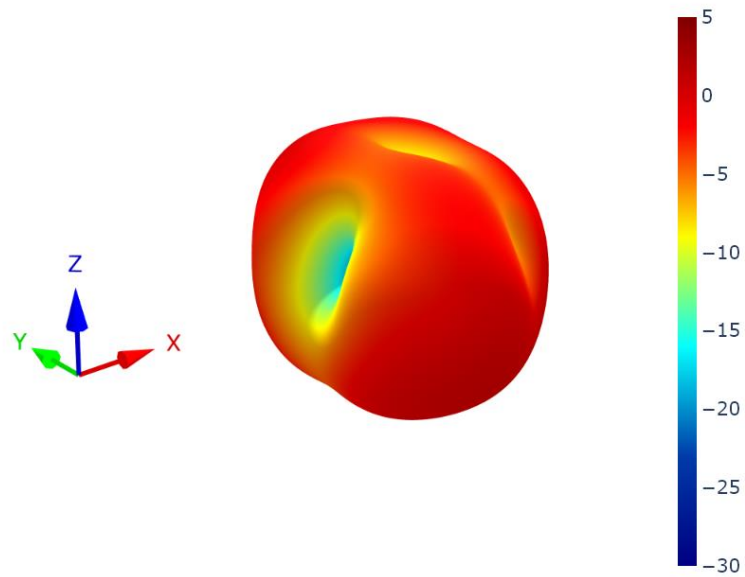

7.16 Free Space (Bent) Patterns at 750 MHz

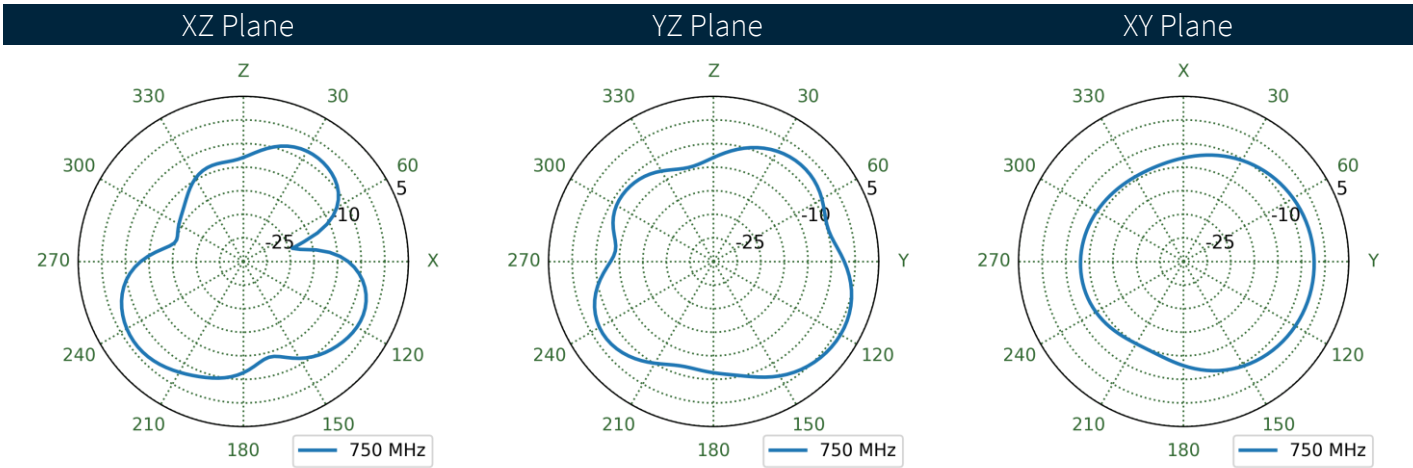
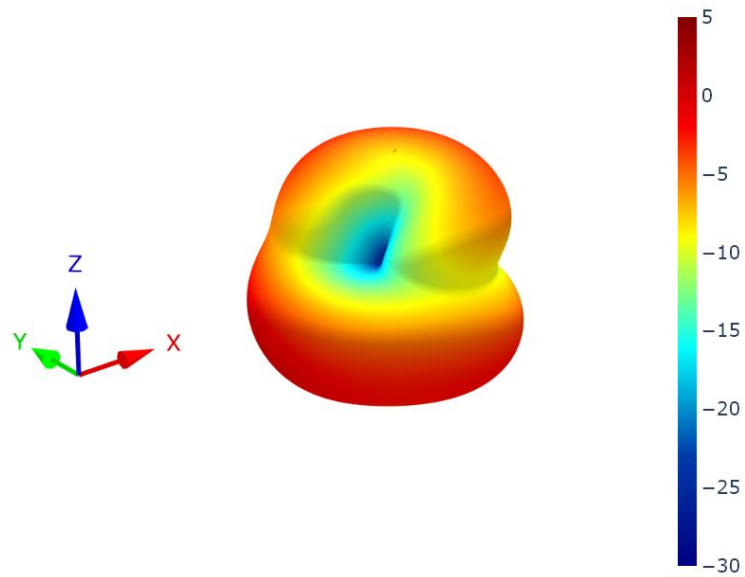

7.17 Free Space (Straight) Patterns at 750 MHz

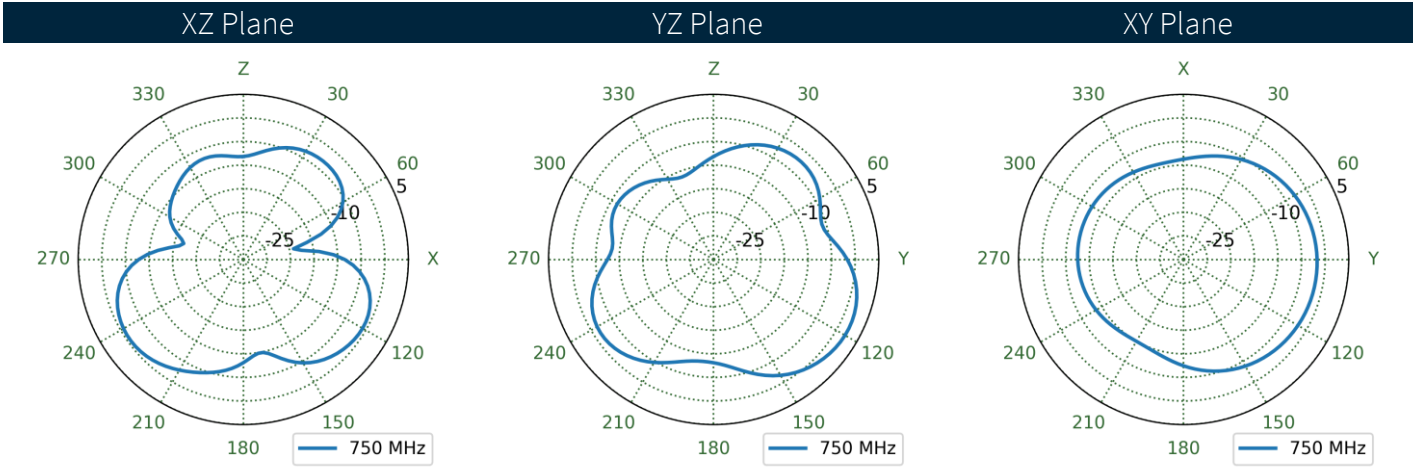
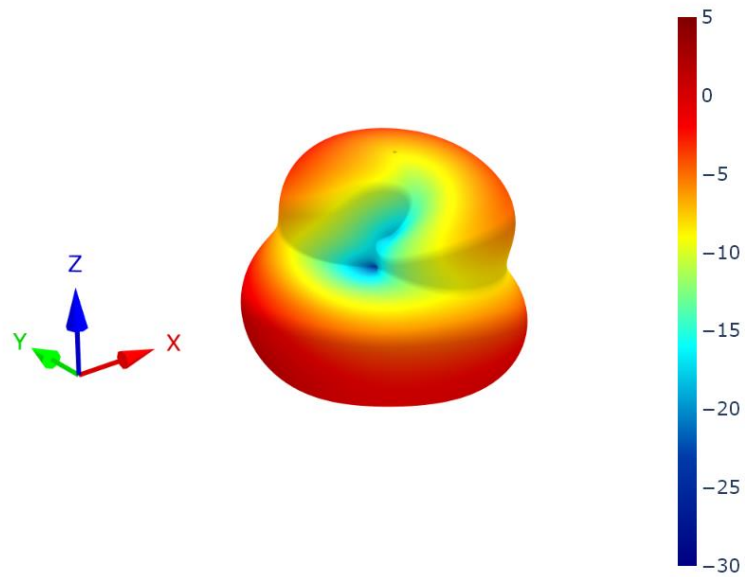

7.18 15x9cm Ground Plane (Bent) Patterns at 890 MHz

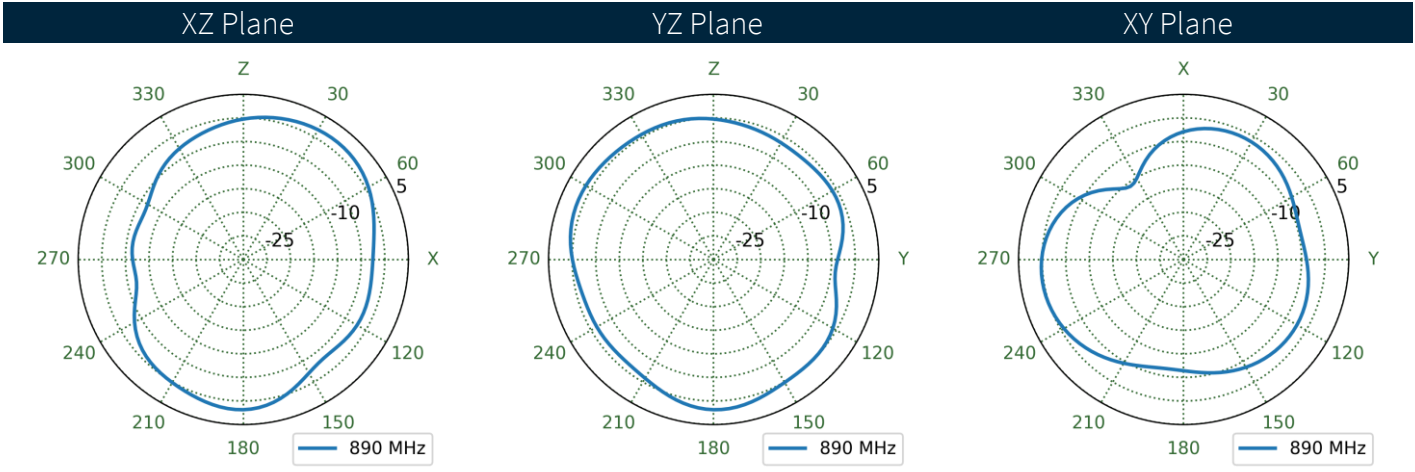
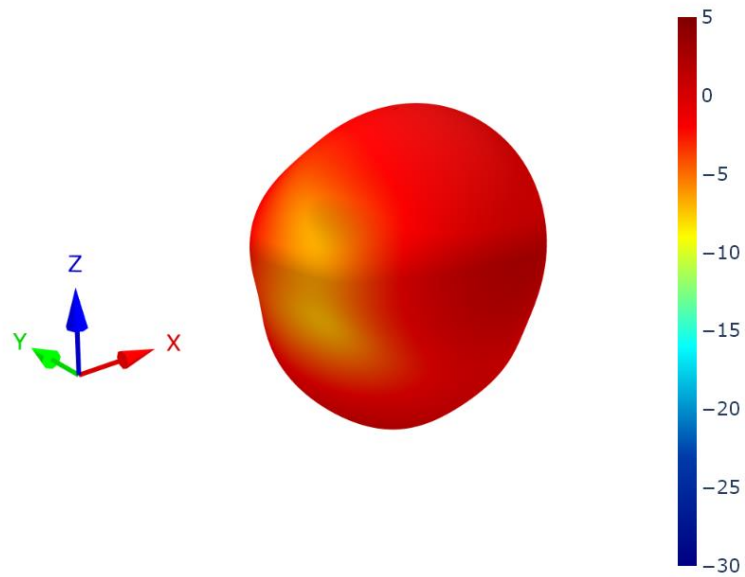

7.19 15x9cm Ground Plane (Straight) Patterns at 890 MHz

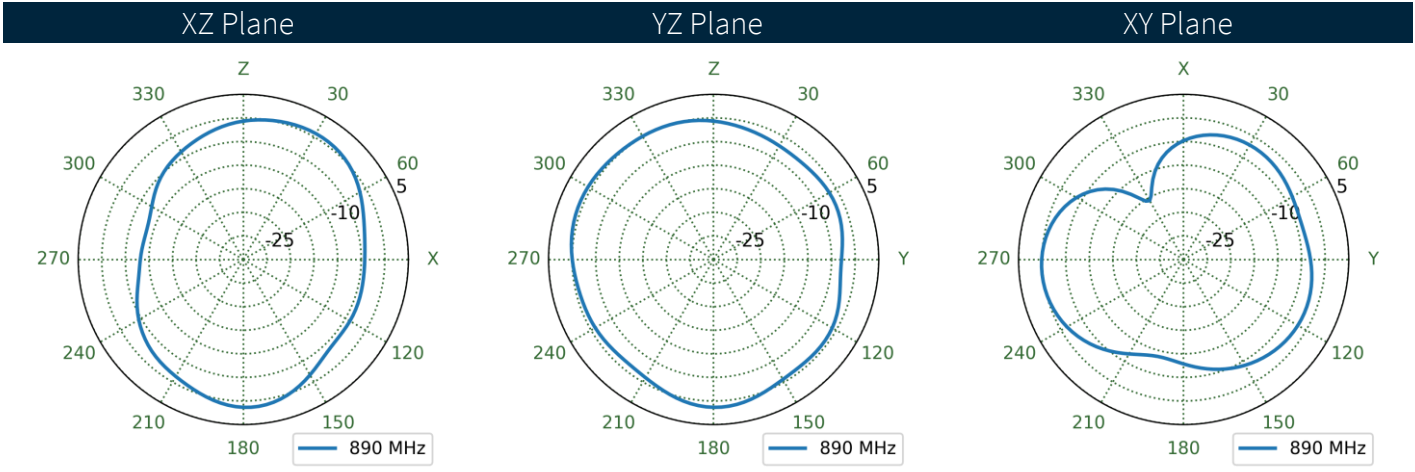
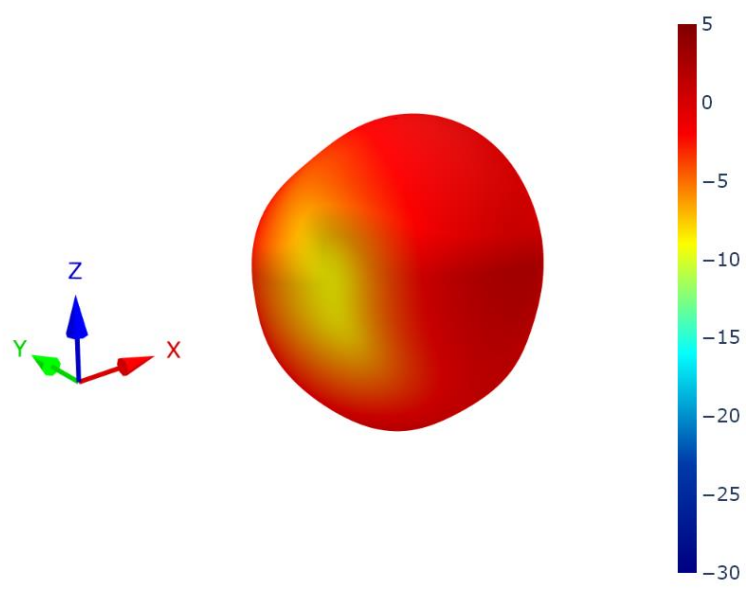

**7.20** 30x30cm Ground Plane Center (Bent) Patterns at 890 MHz

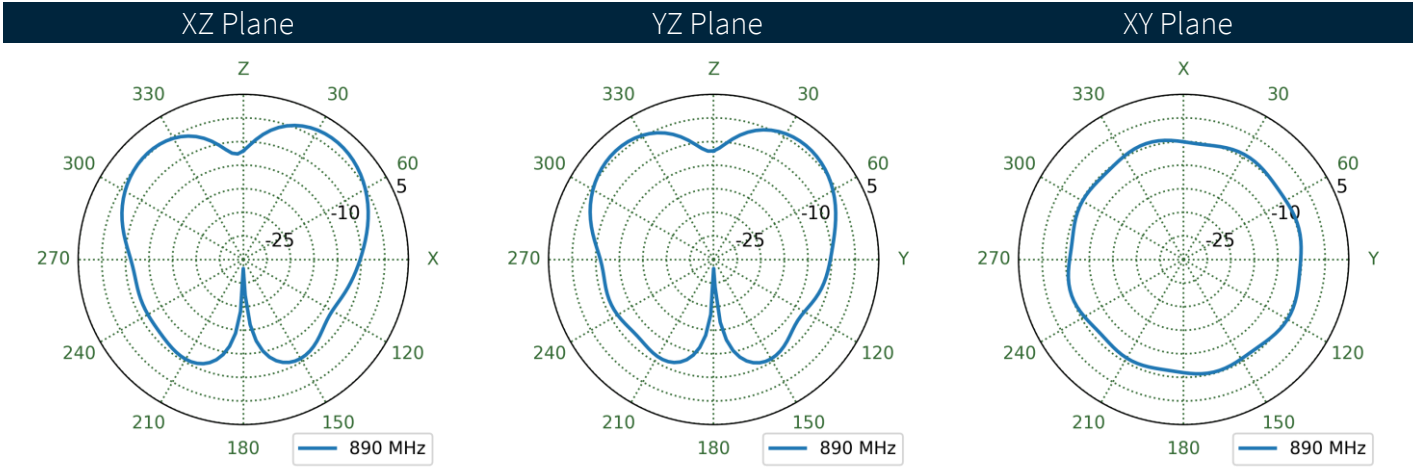
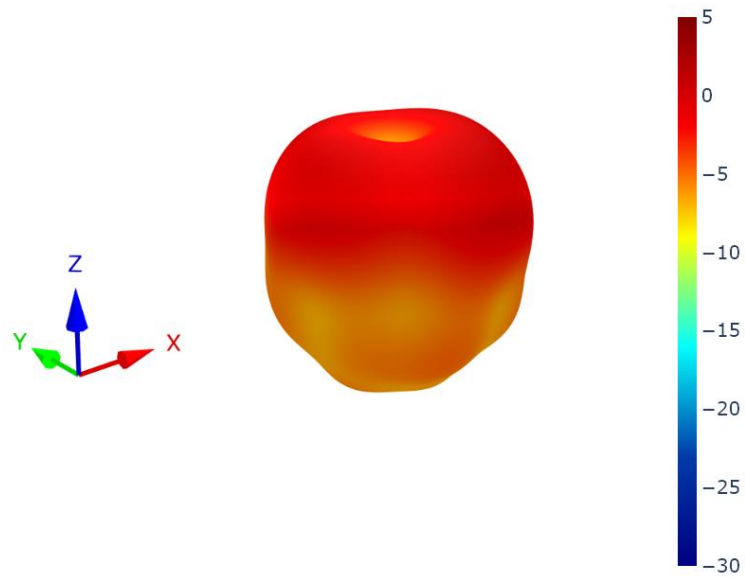



7.21 30x30cm Ground Plane Center (Straight) Patterns at 890 MHz

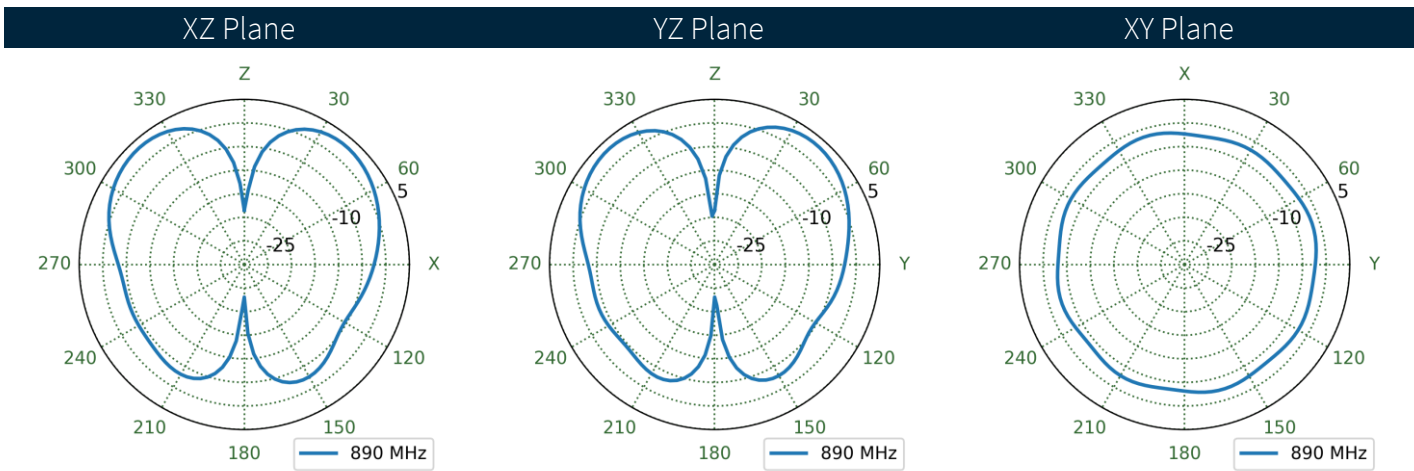
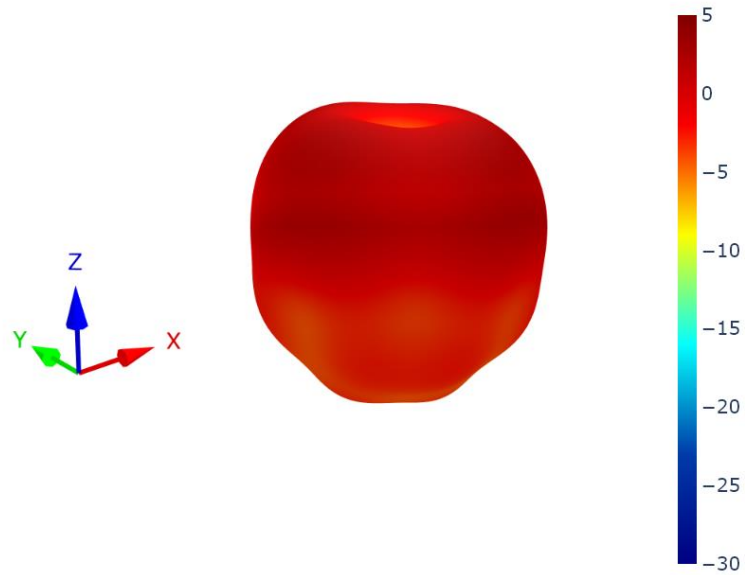

7.22 30x30cm Ground Plane Edge (Bent) Patterns at 890 MHz

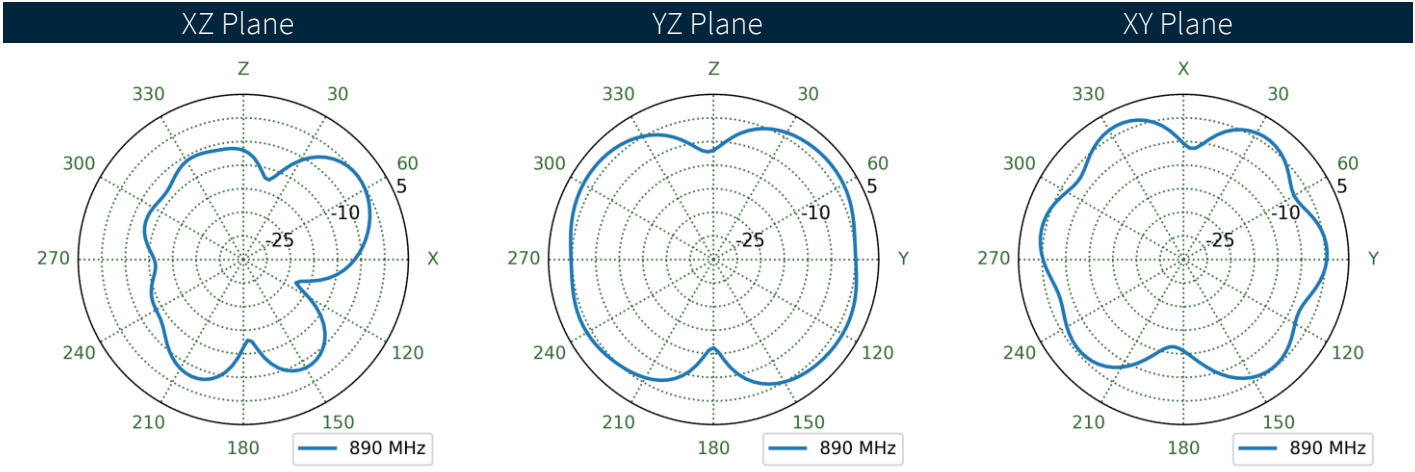
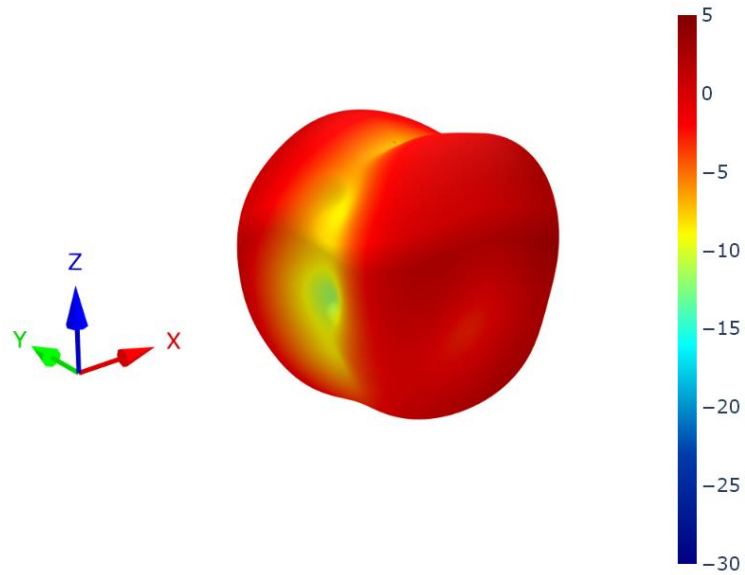

7.23 30x30cm Ground Plane Edge (Straight) Patterns at 890 MHz

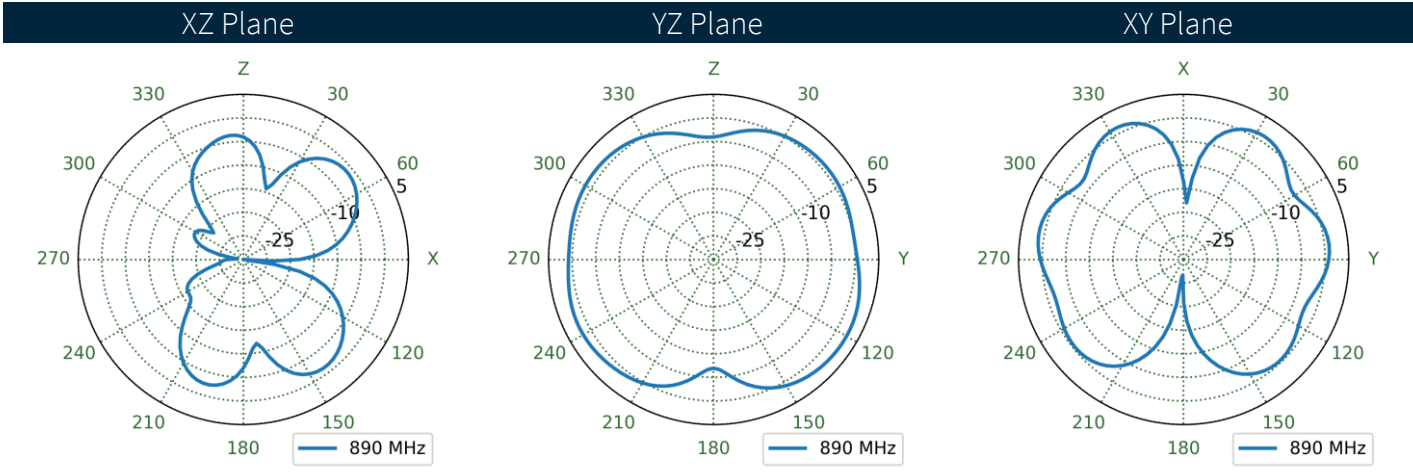
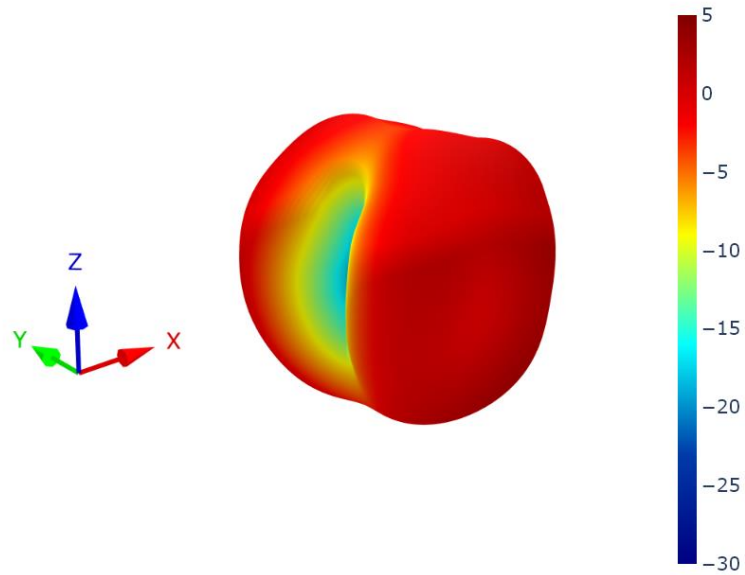

7.24 Free Space (Bent) Patterns at 890 MHz

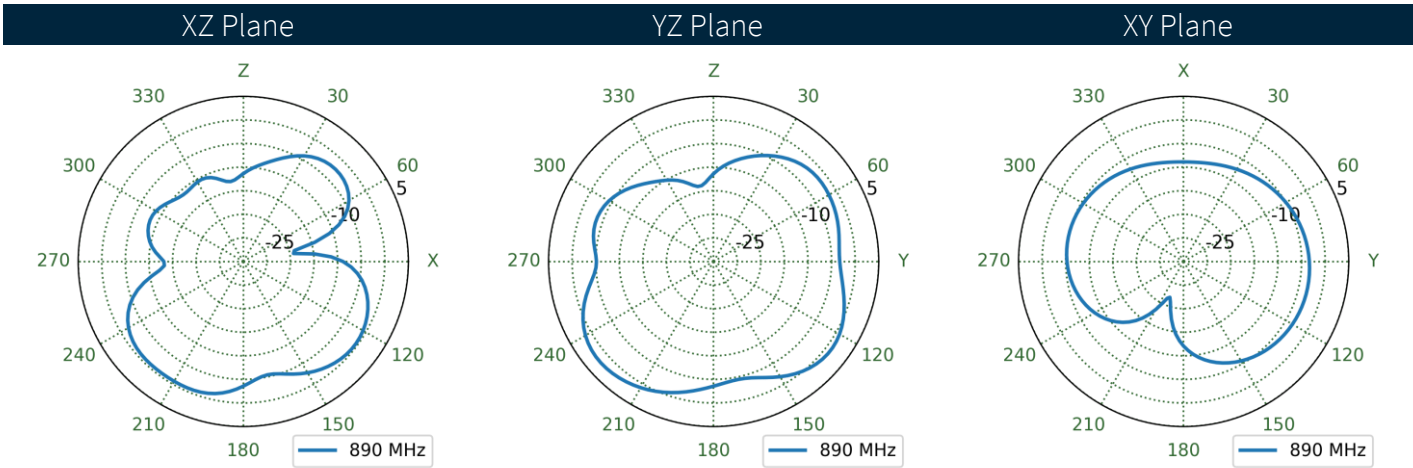
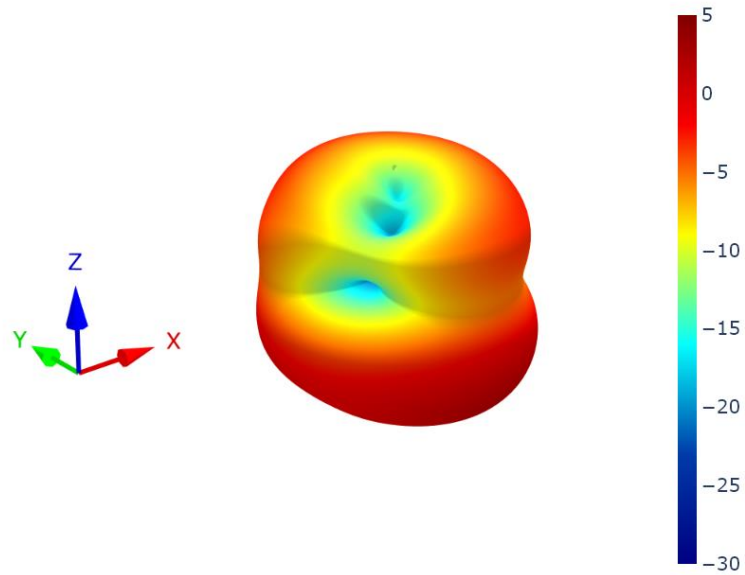

7.25 Free Space (Straight) Patterns at 890 MHz

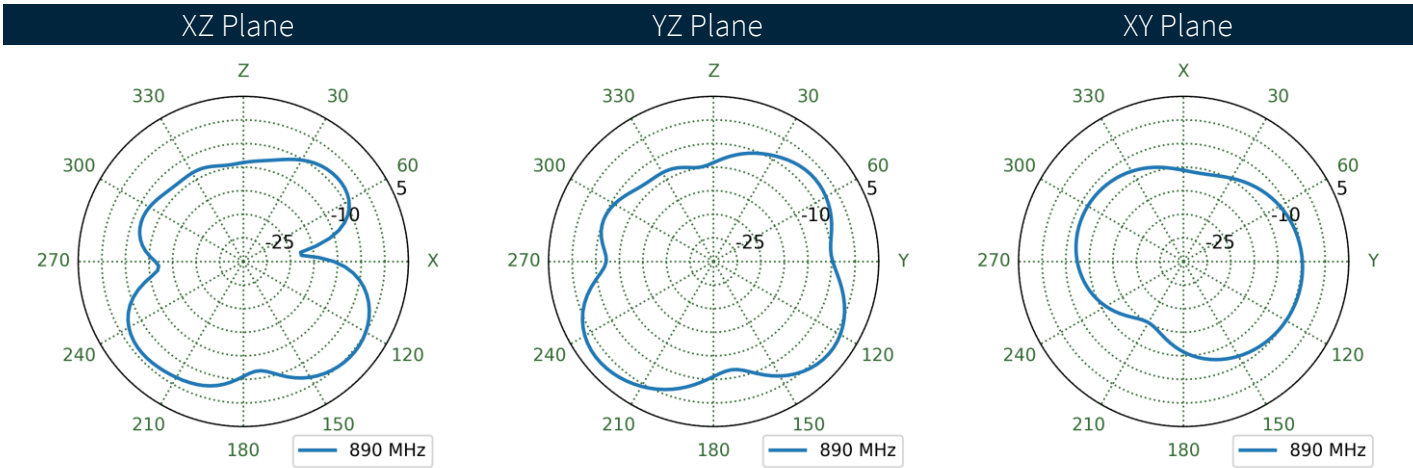
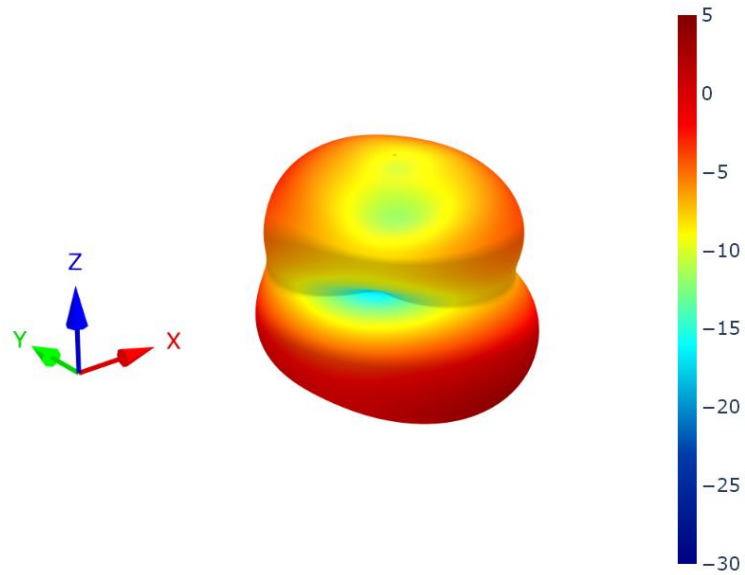

7.26 15x9cm Ground Plane (Bent) Patterns at 1470 MHz

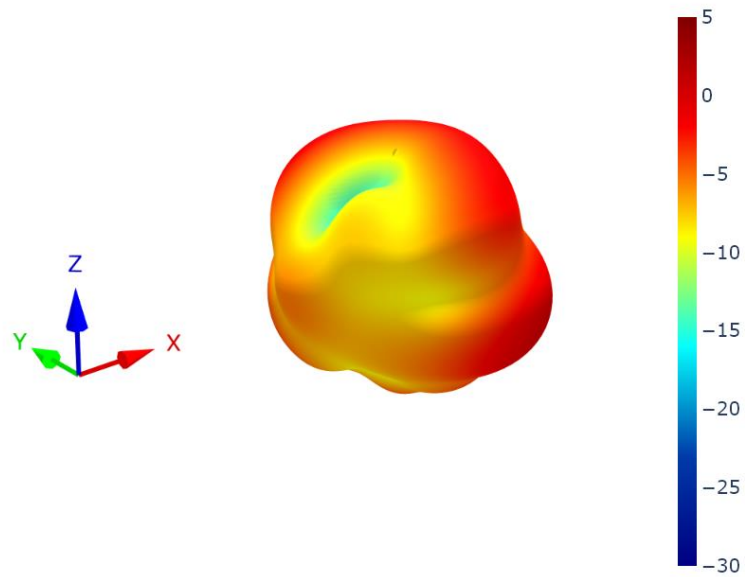

XZ Plane                      YZ Plane                      XY Plane

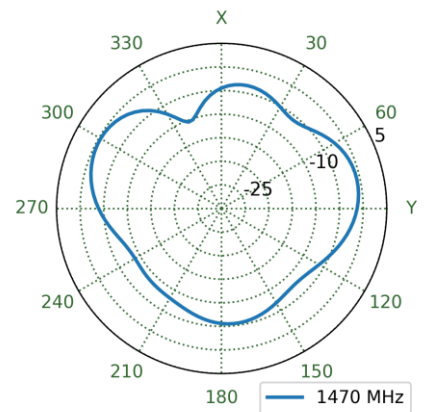
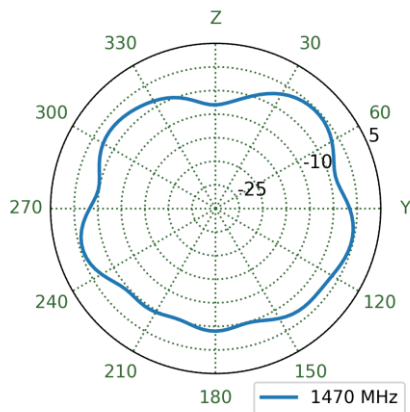
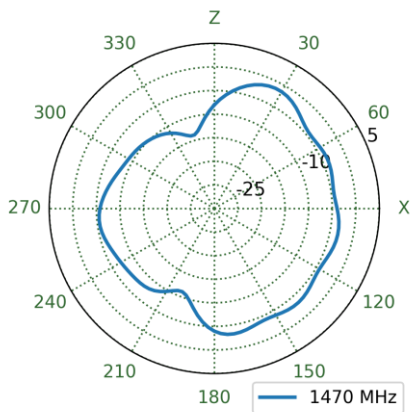

7.27 15x9cm Ground Plane (Straight) Patterns at 1470 MHz

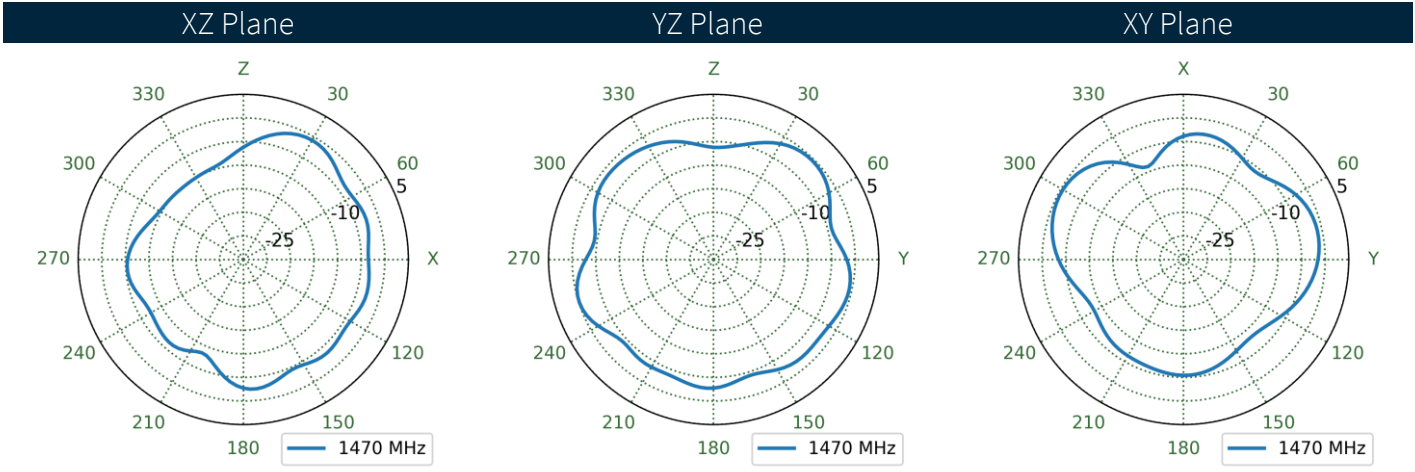
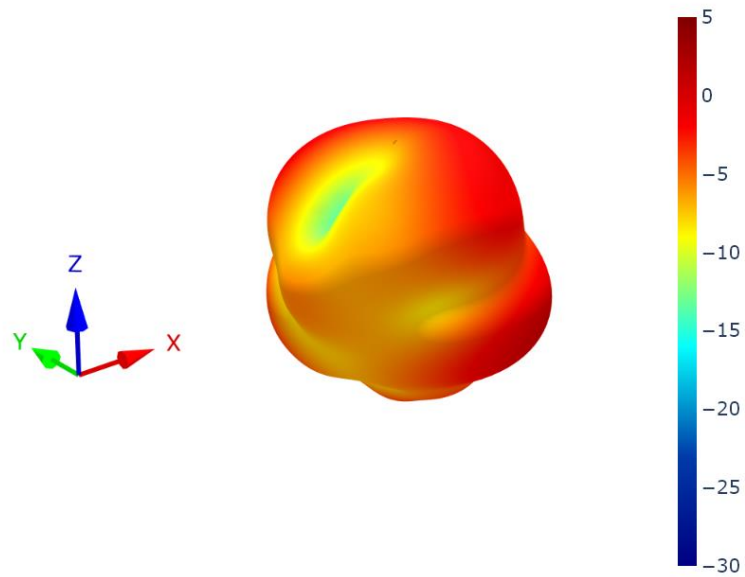

7.28 30x30cm Ground Plane Center (Bent) Patterns at 1470 MHz

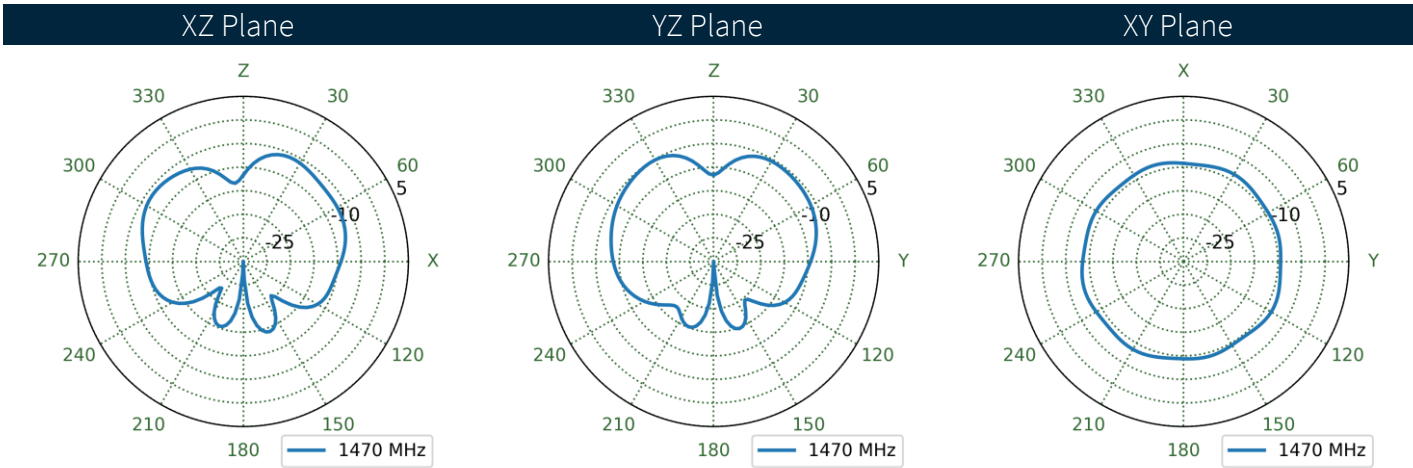
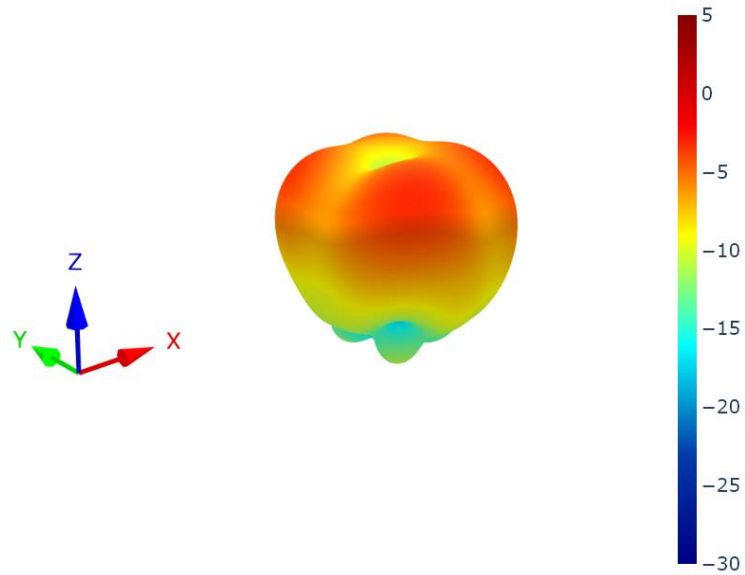



7.29 30x30cm Ground Plane Center (Straight) Patterns at 1470 MHz

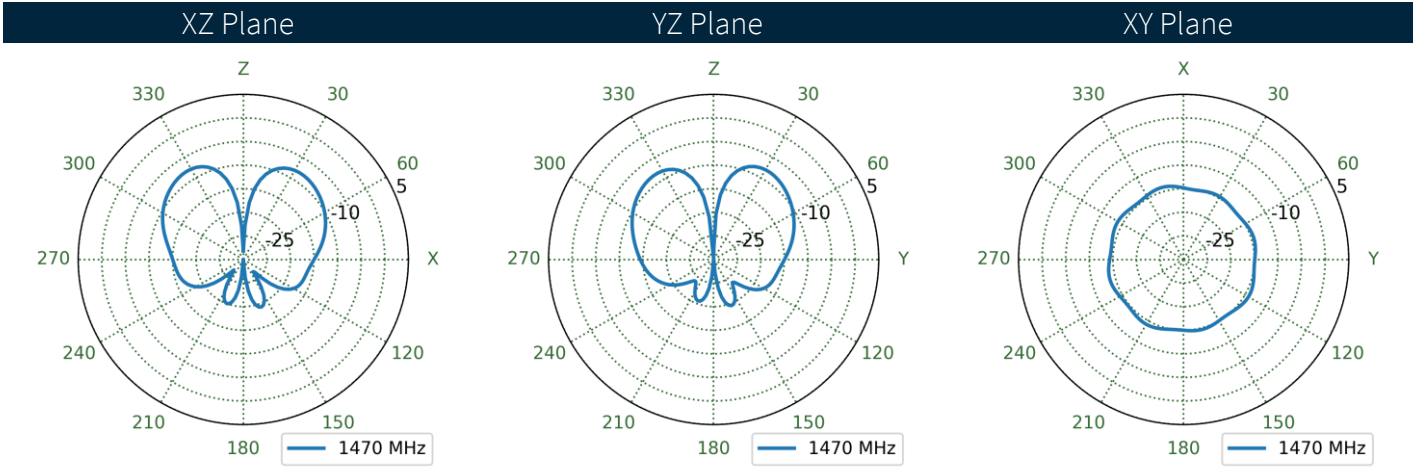
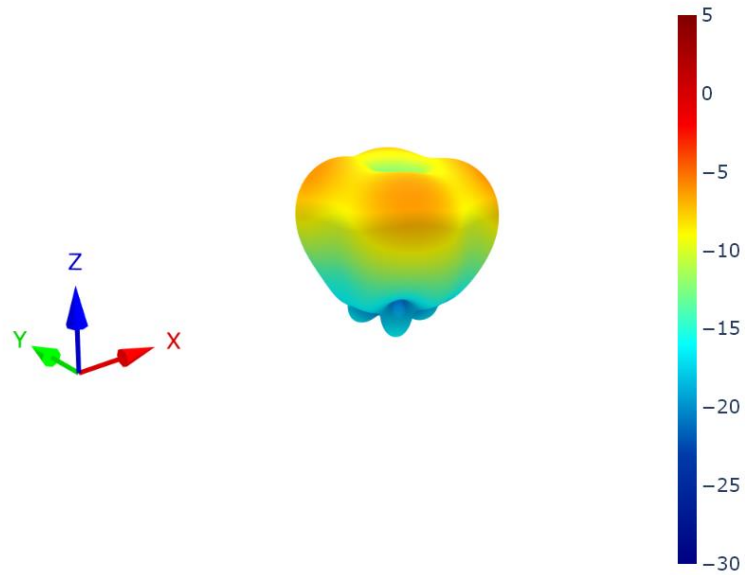

**7.30** 30x30cm Ground Plane Edge (Bent) Patterns at 1470 MHz

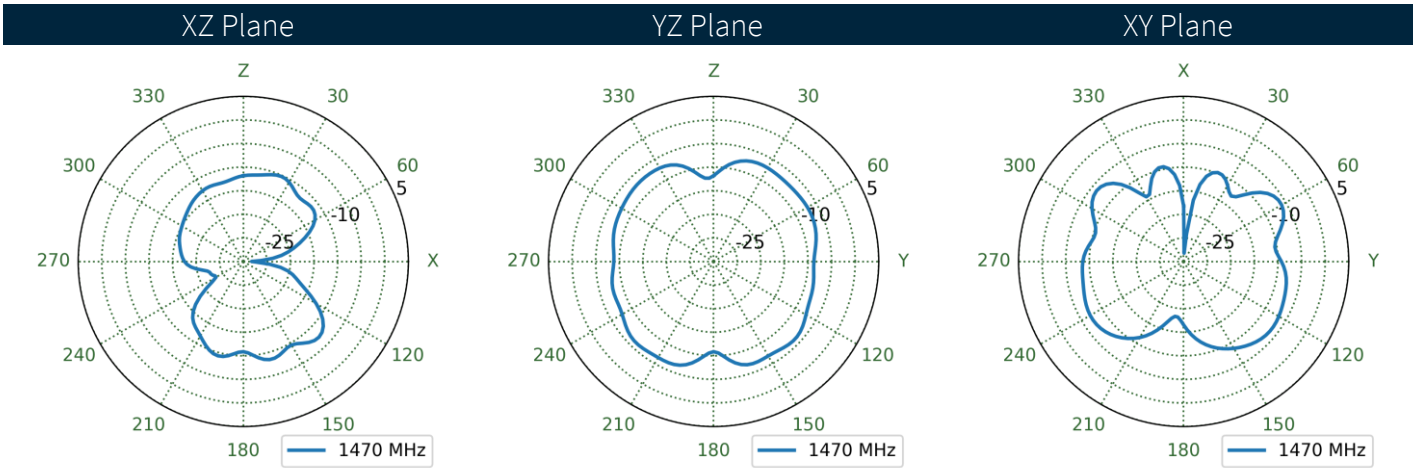
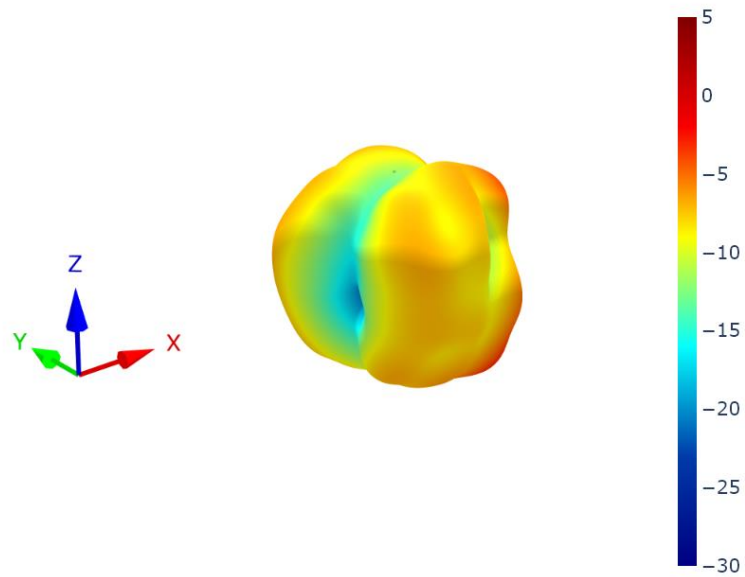

7.31 30x30cm Ground Plane Edge (Straight) Patterns at 1470 MHz

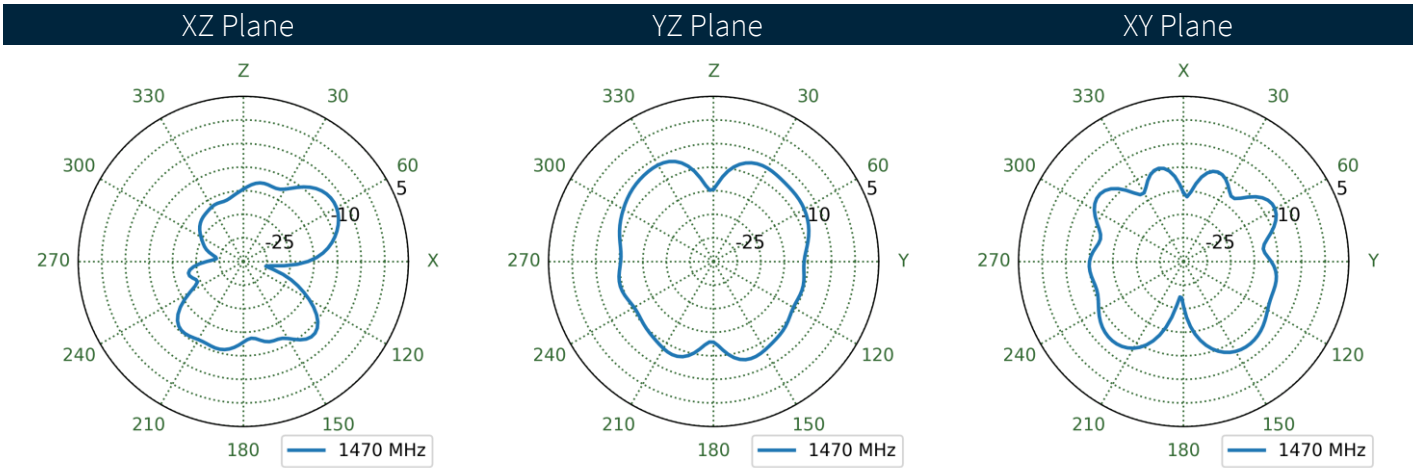
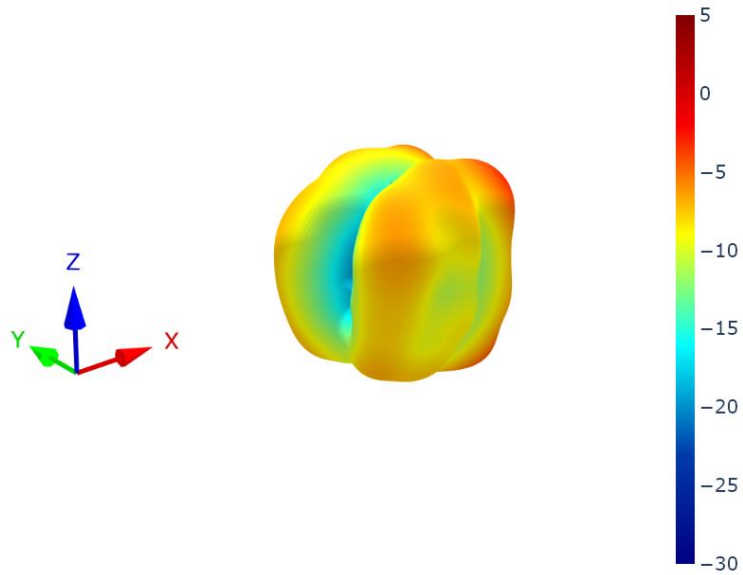

7.32 Free Space (Bent) Patterns at 1470 MHz

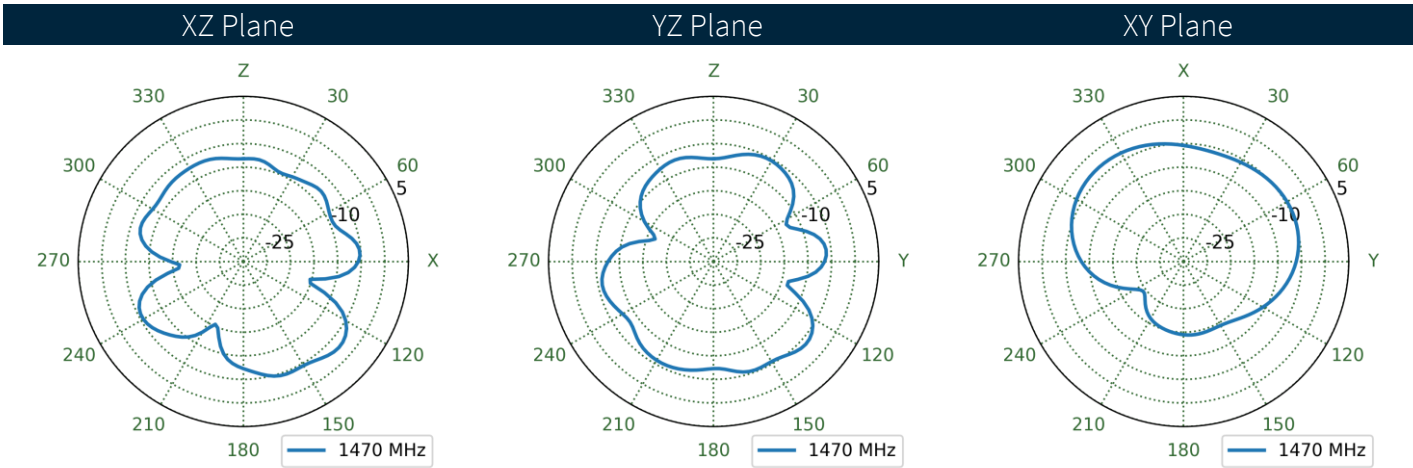
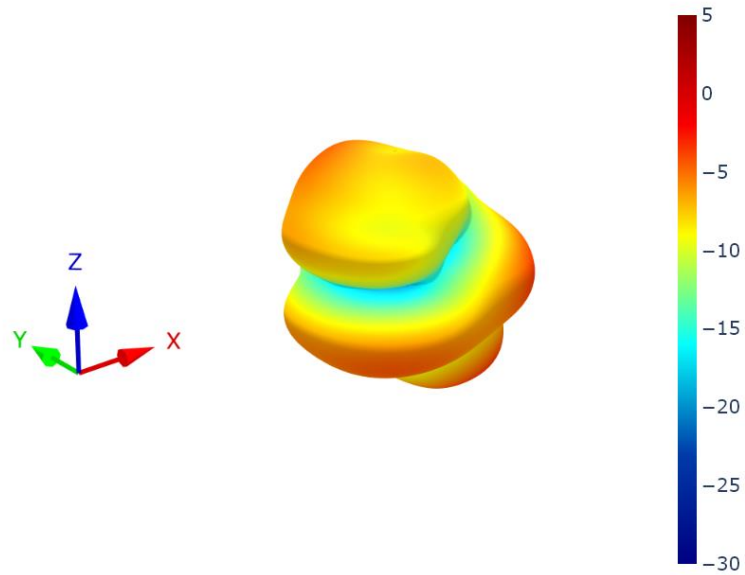

7.33 Free Space (Straight) Patterns at 1470 MHz

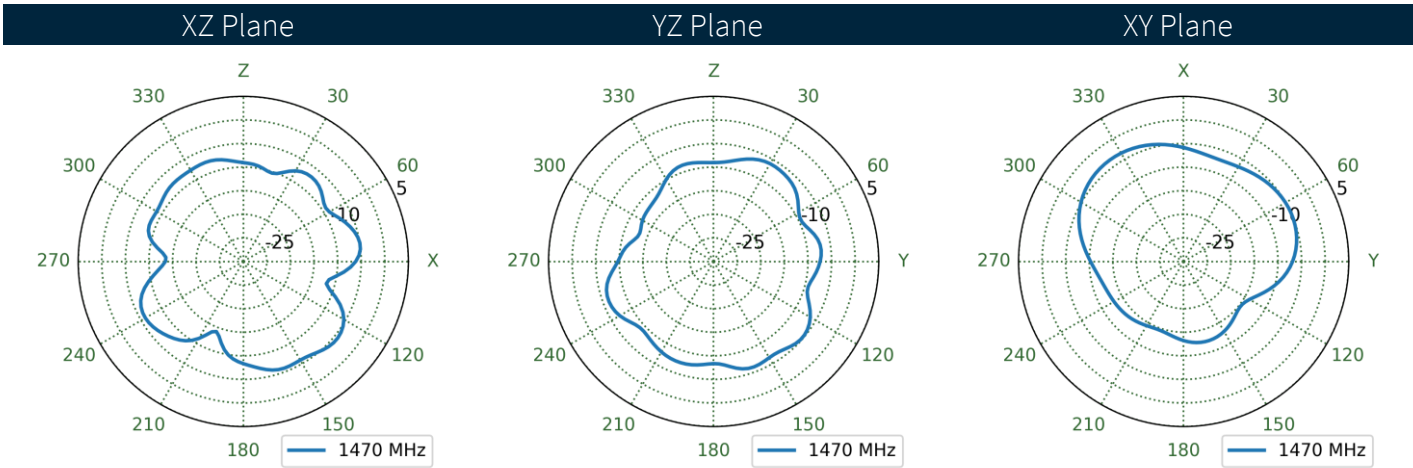
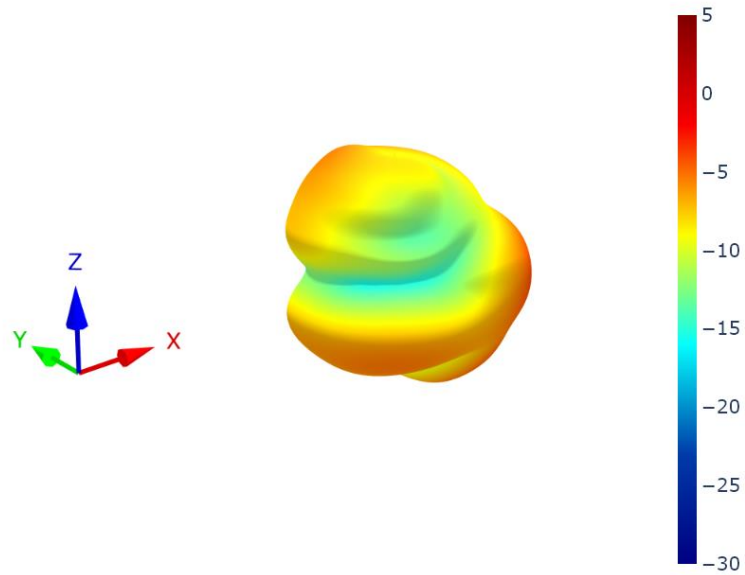

7.34 15x9cm Ground Plane (Bent) Patterns at 1950 MHz

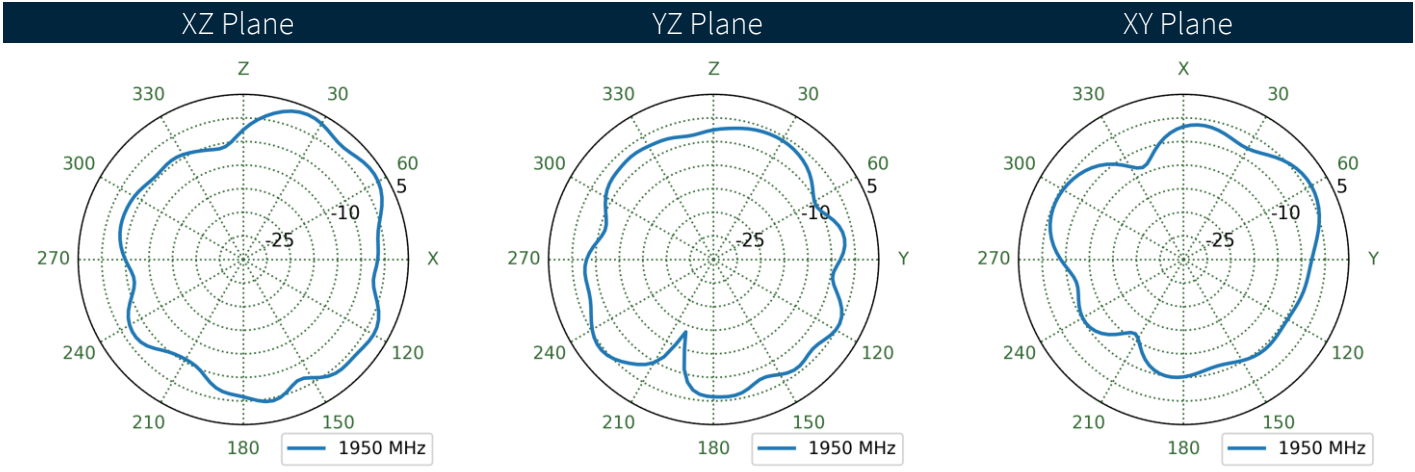
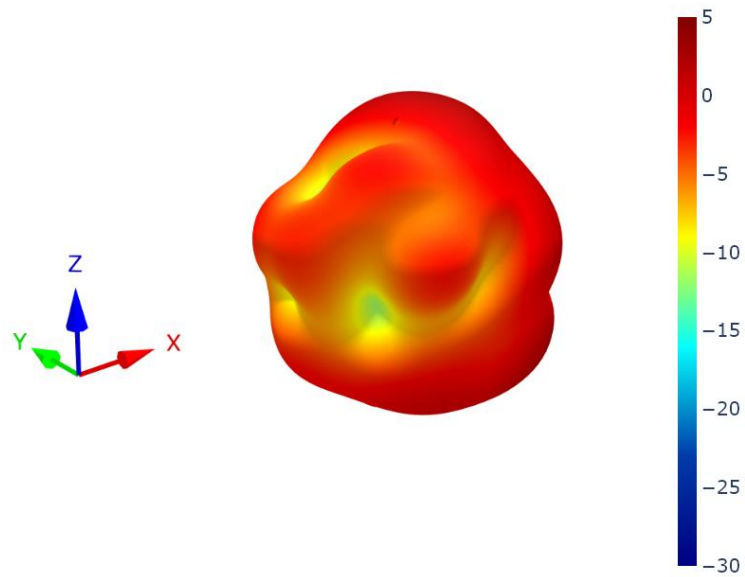

7.35 15x9cm Ground Plane (Straight) Patterns at 1950 MHz

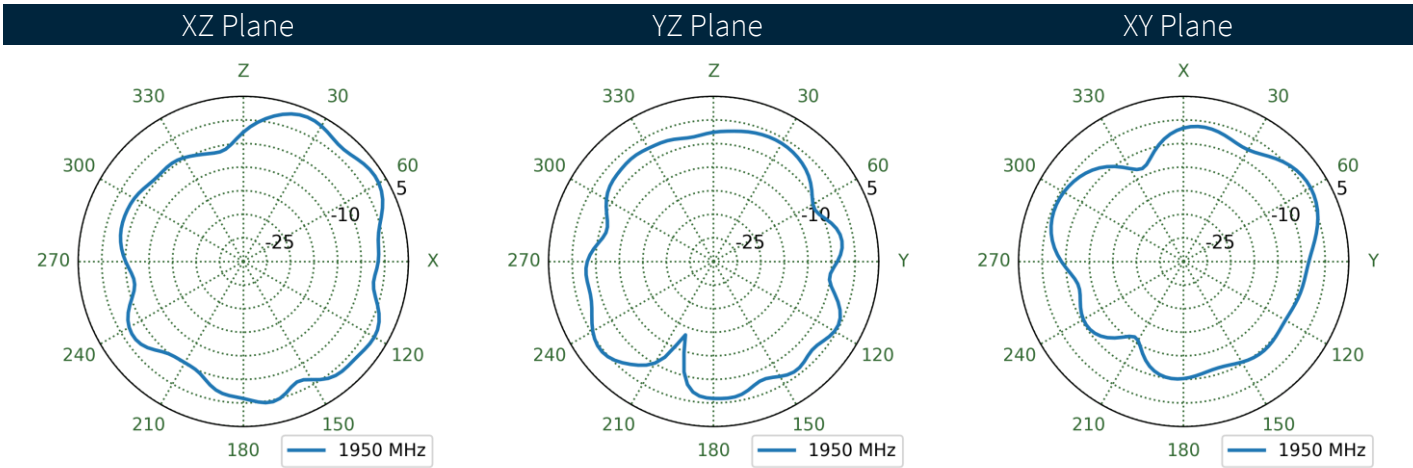
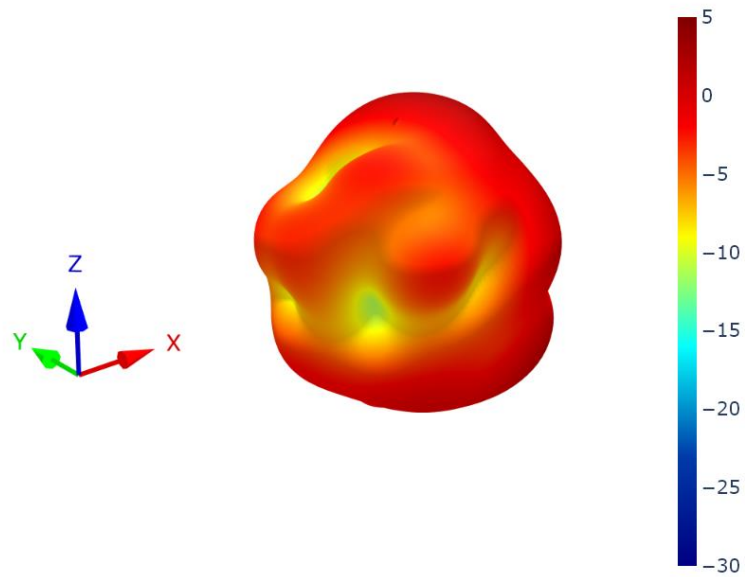

7.36 30x30cm Ground Plane Center (Bent) Patterns at 1950 MHz

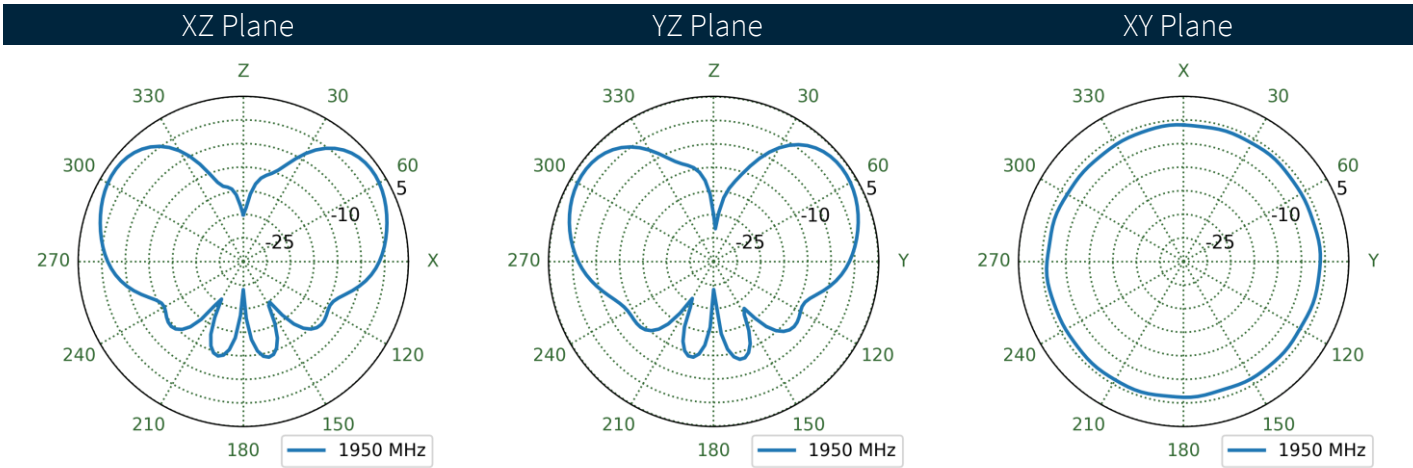
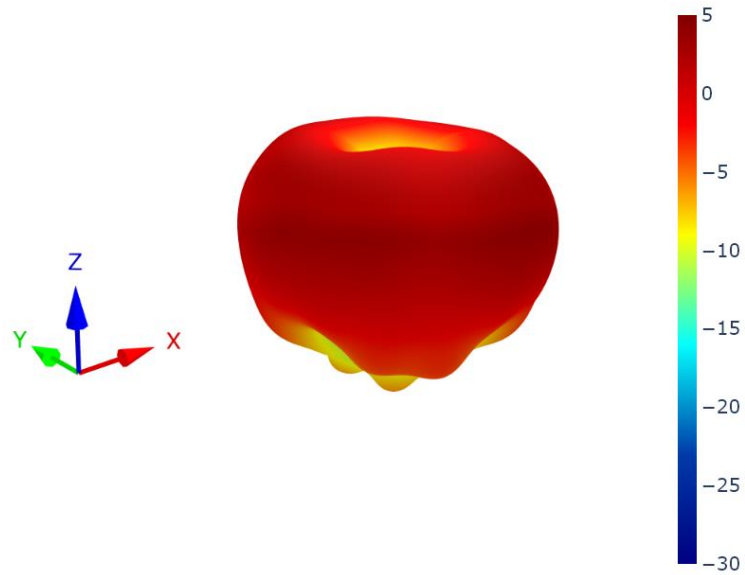



7.37 30x30cm Ground Plane Center (Straight) Patterns at 1950 MHz

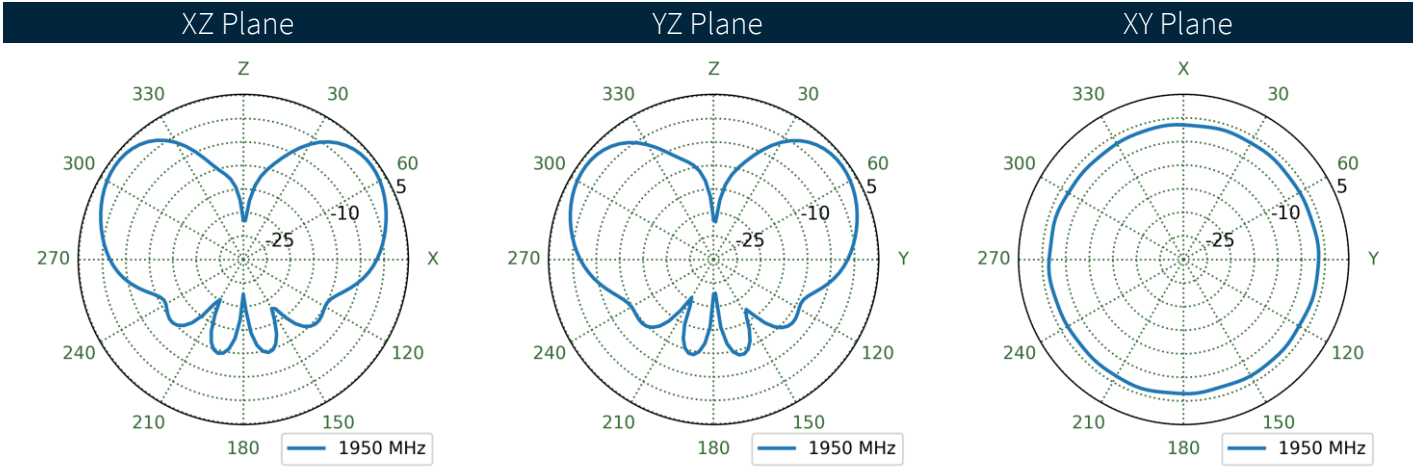
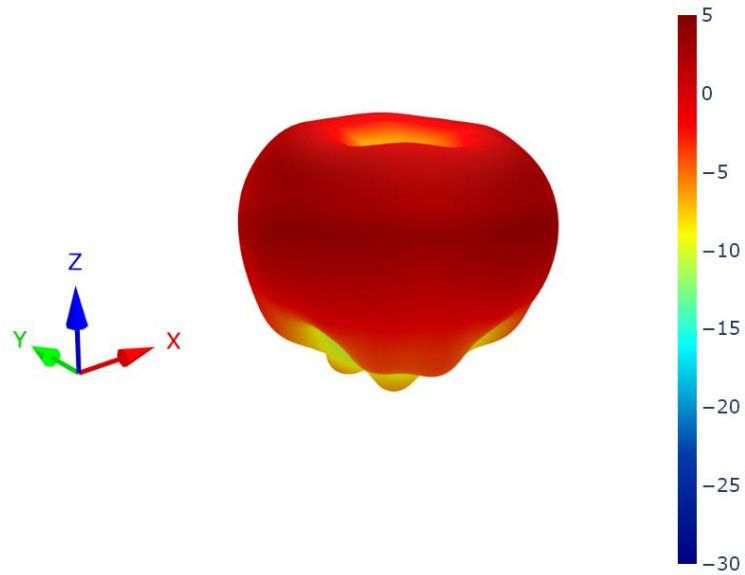

**7.38** 30x30cm Ground Plane Edge (Bent) Patterns at 1950 MHz

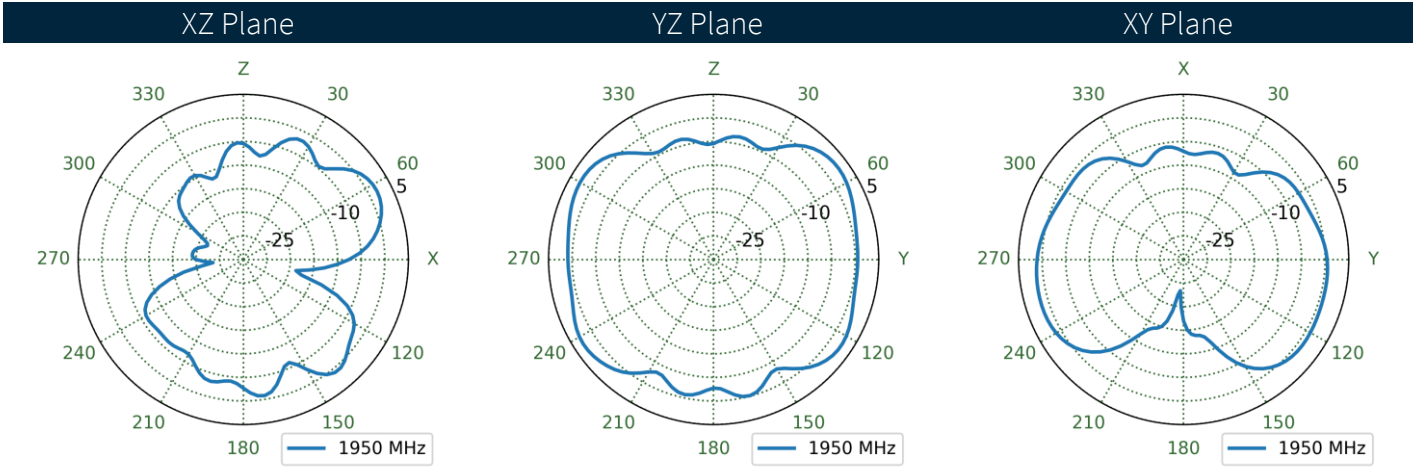
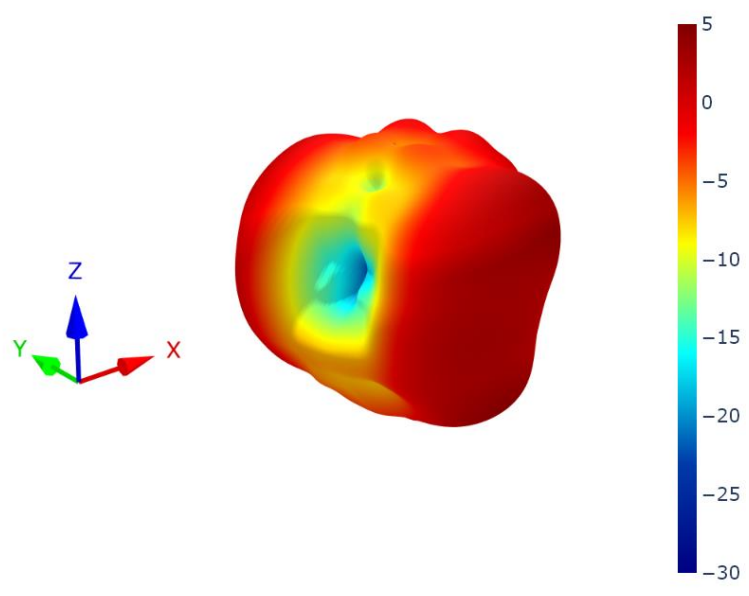

7.39 30x30cm Ground Plane Edge (Straight) Patterns at 1950 MHz

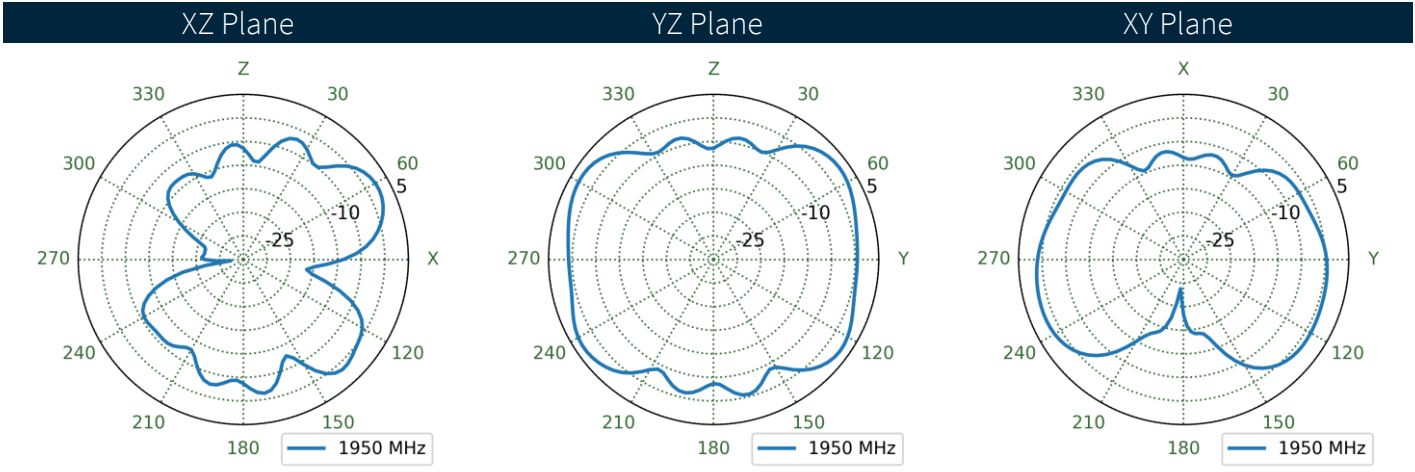
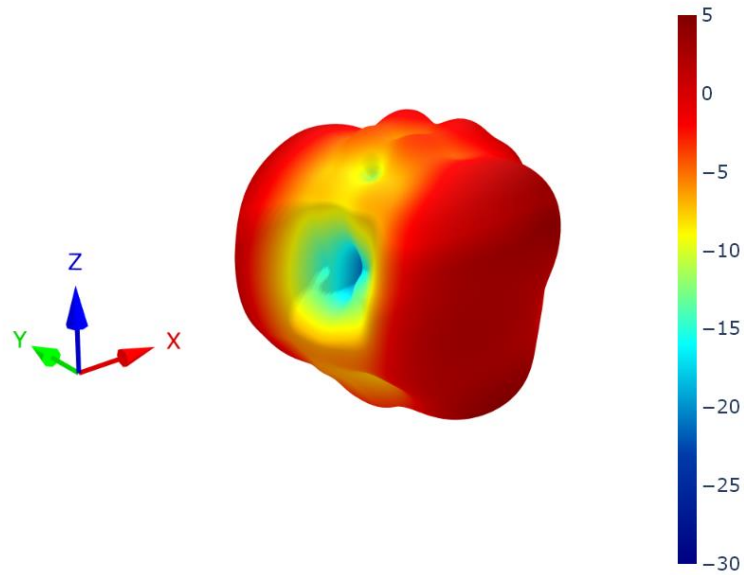

7.40 Free Space (Bent) Patterns at 1950 MHz

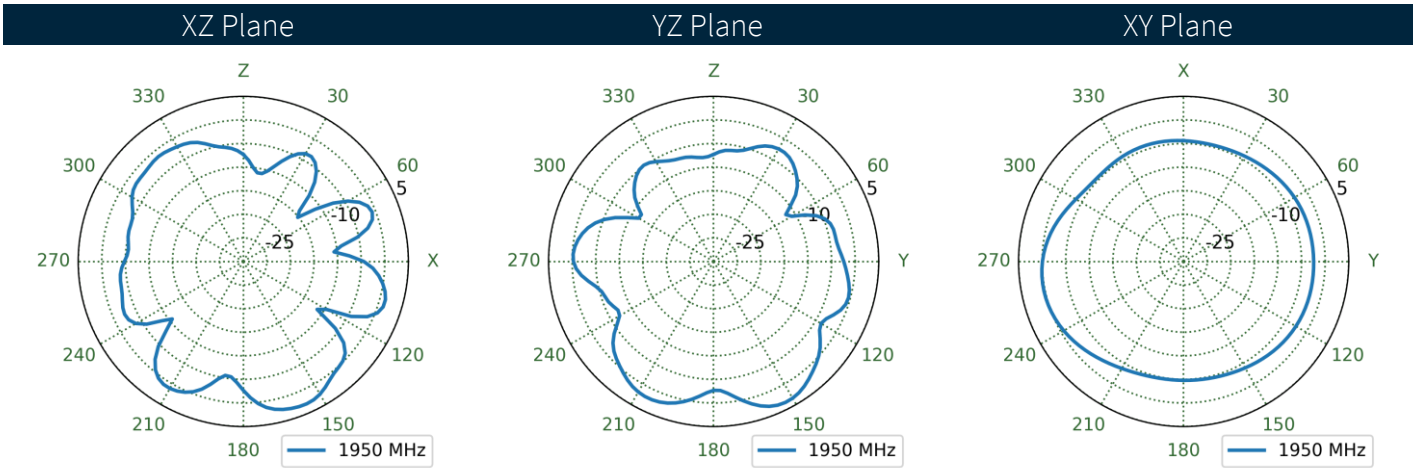
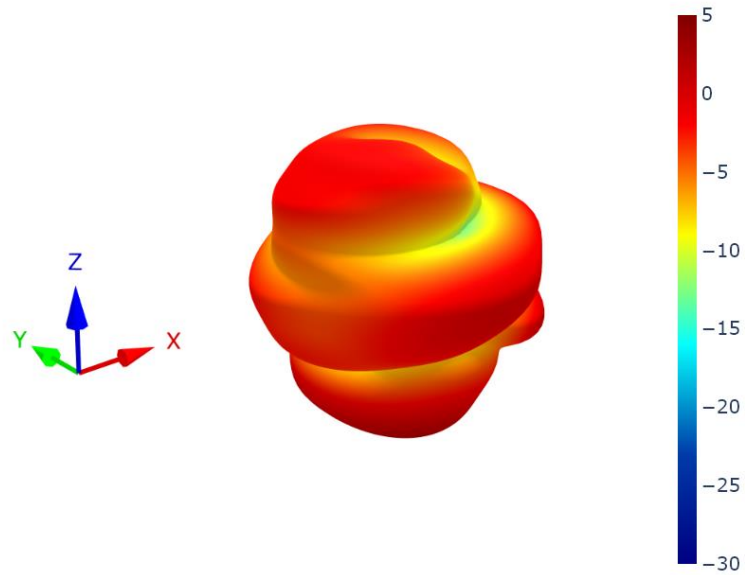

7.41 Free Space (Straight) Patterns at 1950 MHz

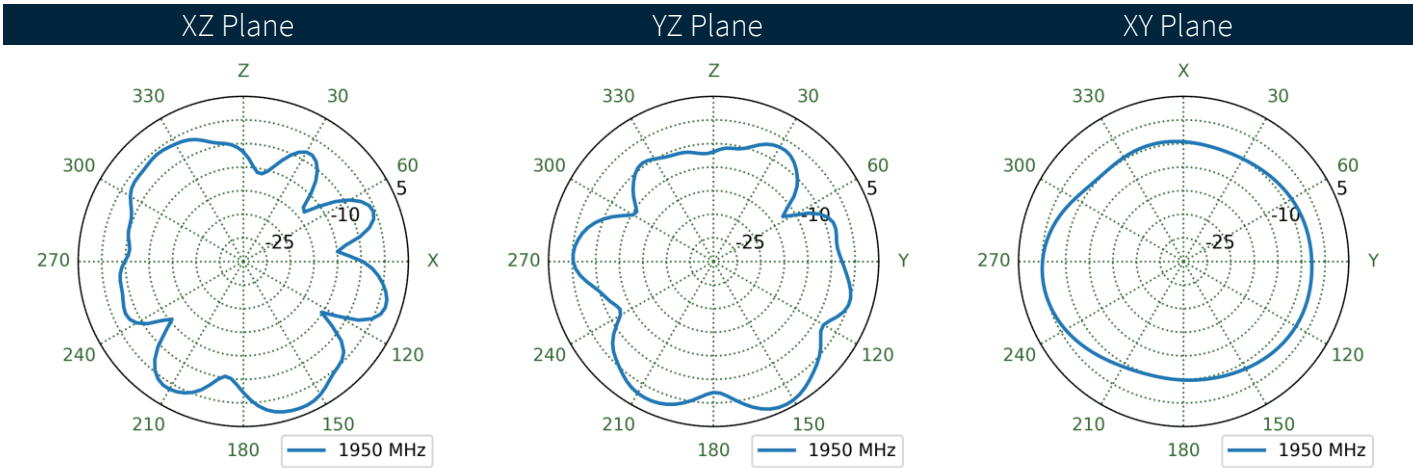
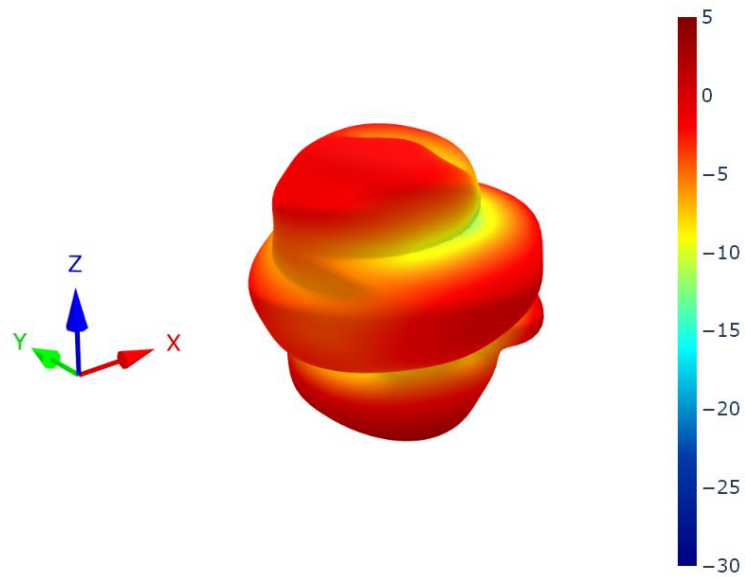

7.42 15x9cm Ground Plane (Bent) Patterns at 2490 MHz

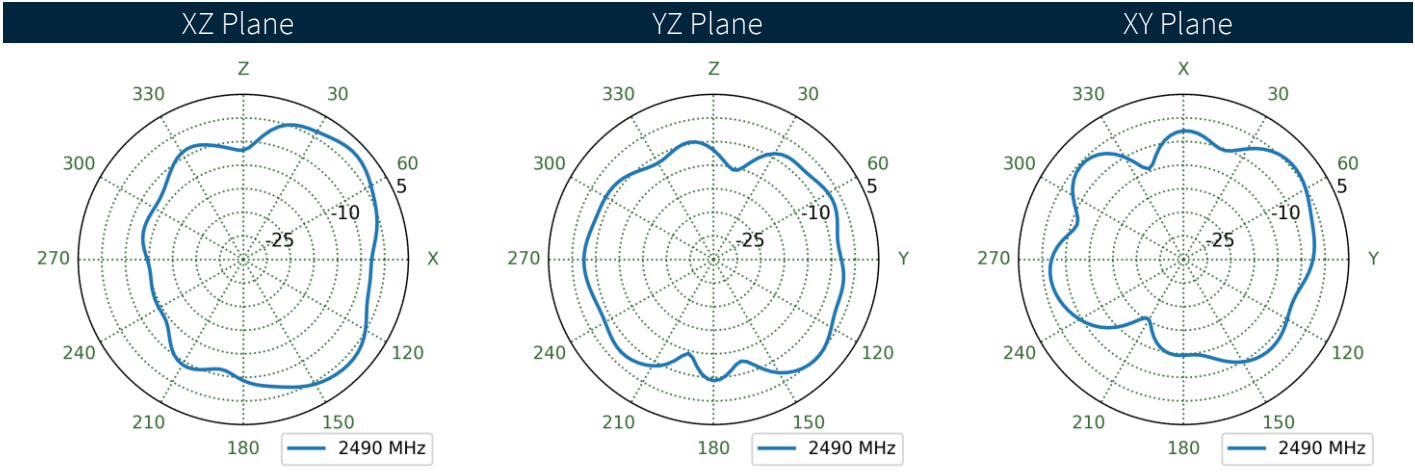
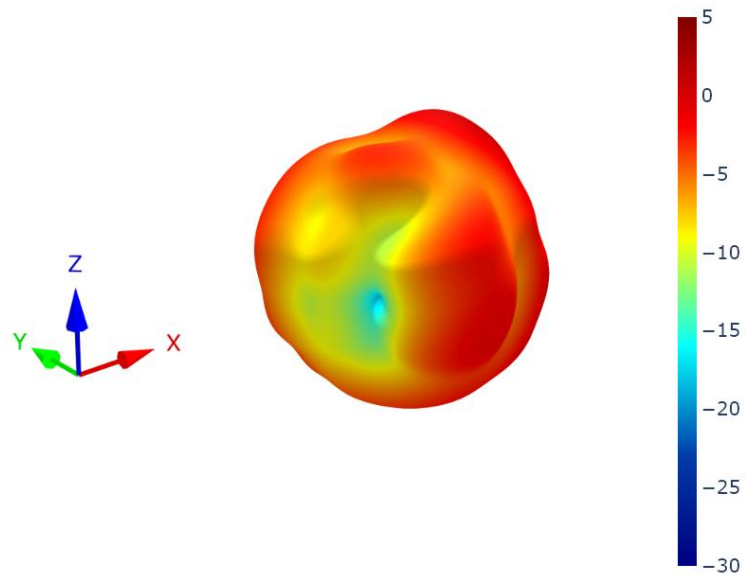

7.43 15x9cm Ground Plane (Straight) Patterns at 2490 MHz

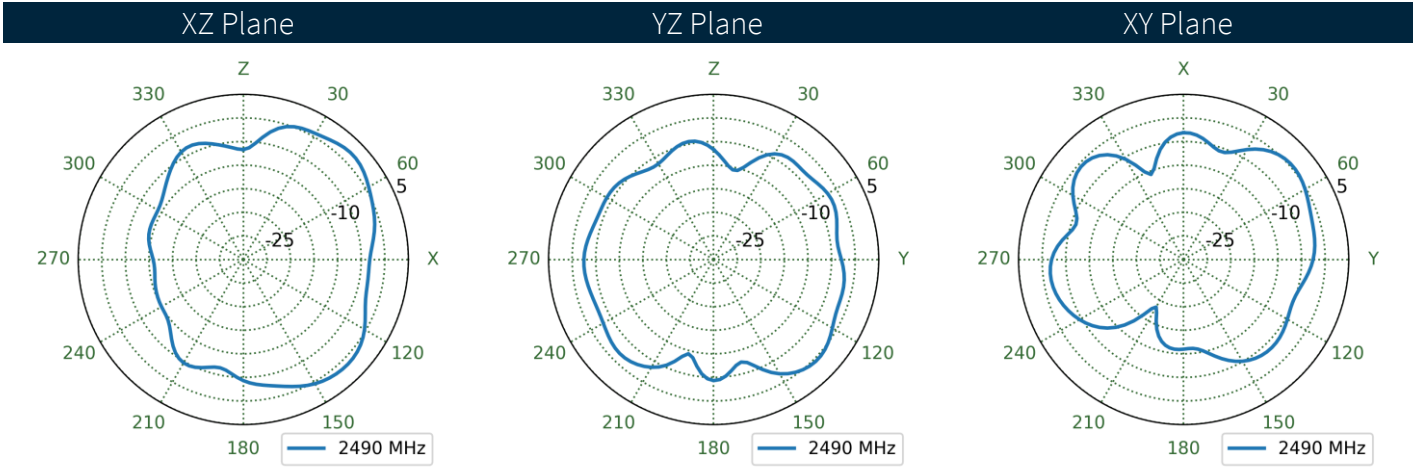
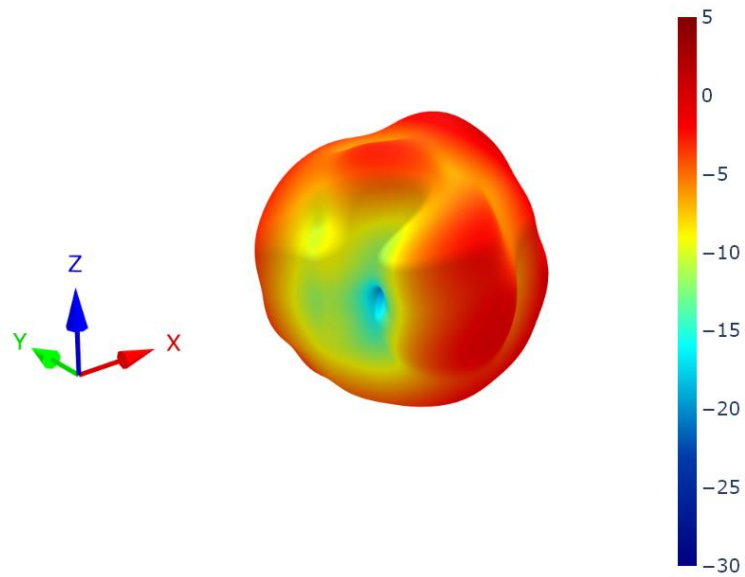

7.44 30x30cm Ground Plane Center (Bent) Patterns at 2490 MHz

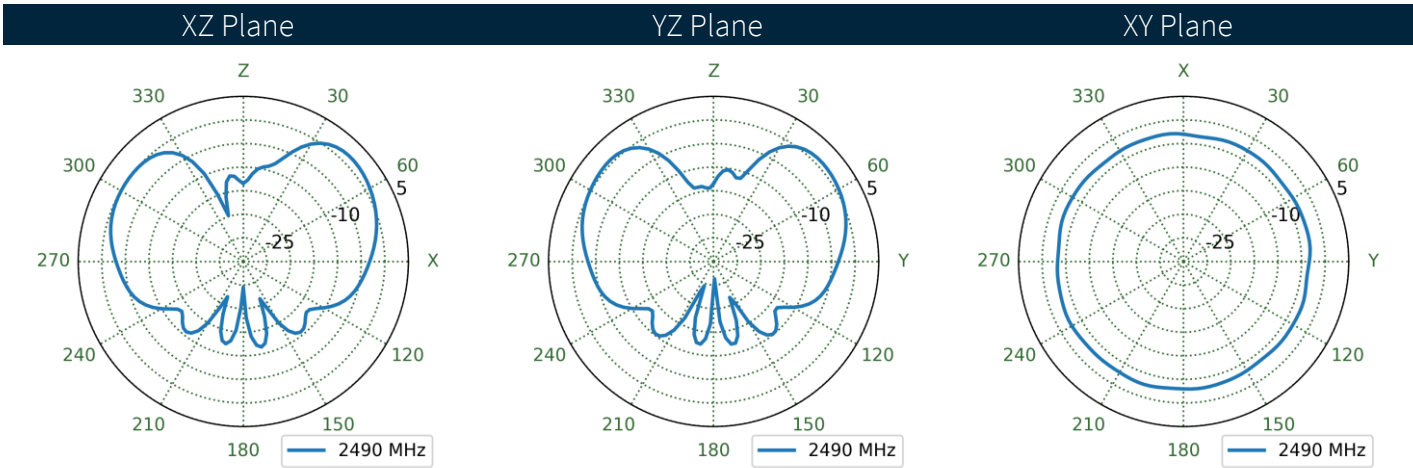
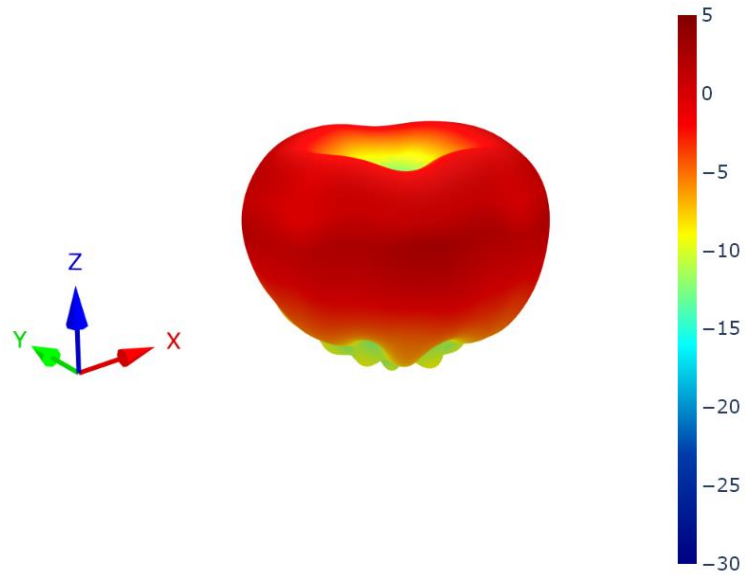



7.45 30x30cm Ground Plane Center (Straight) Patterns at 2490 MHz

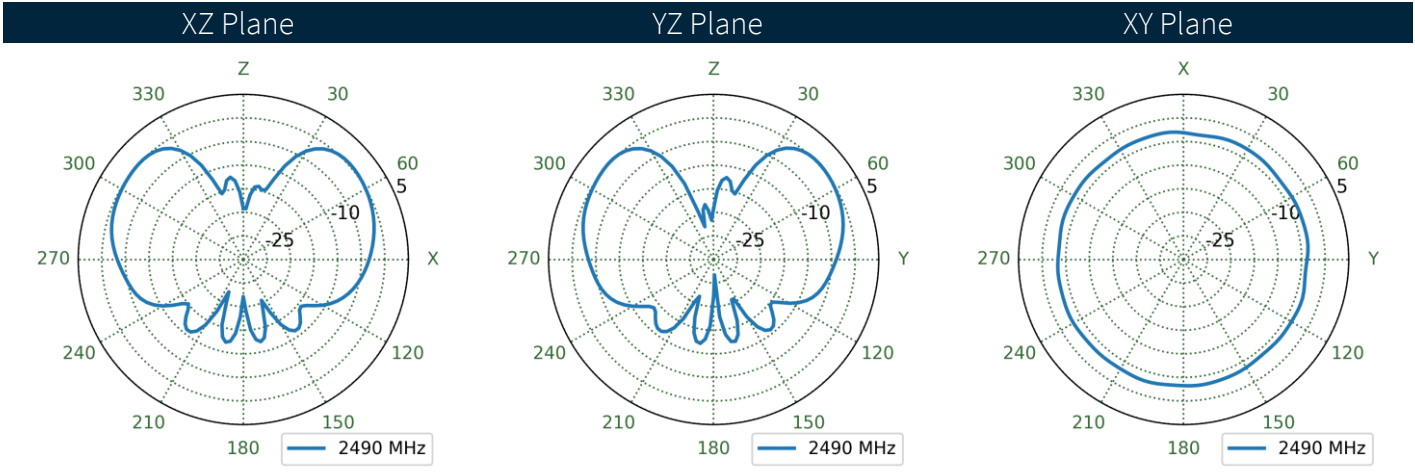
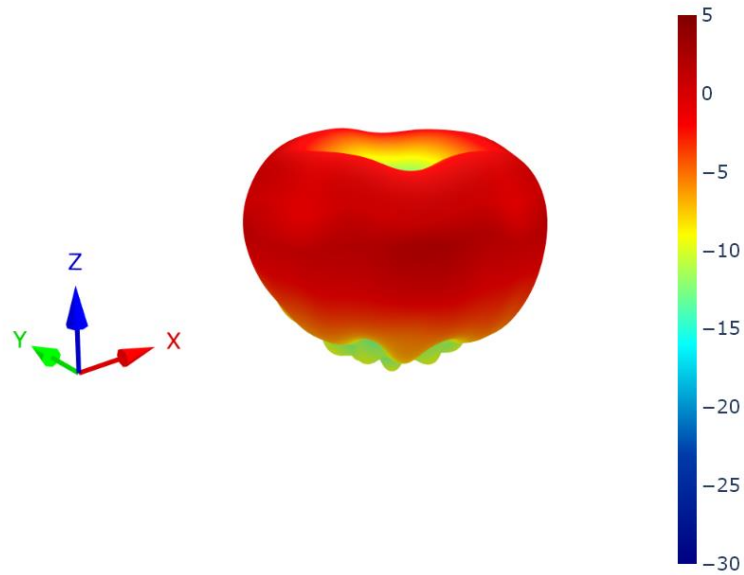

7.46 30x30cm Ground Plane Edge (Bent) Patterns at 2490 MHz

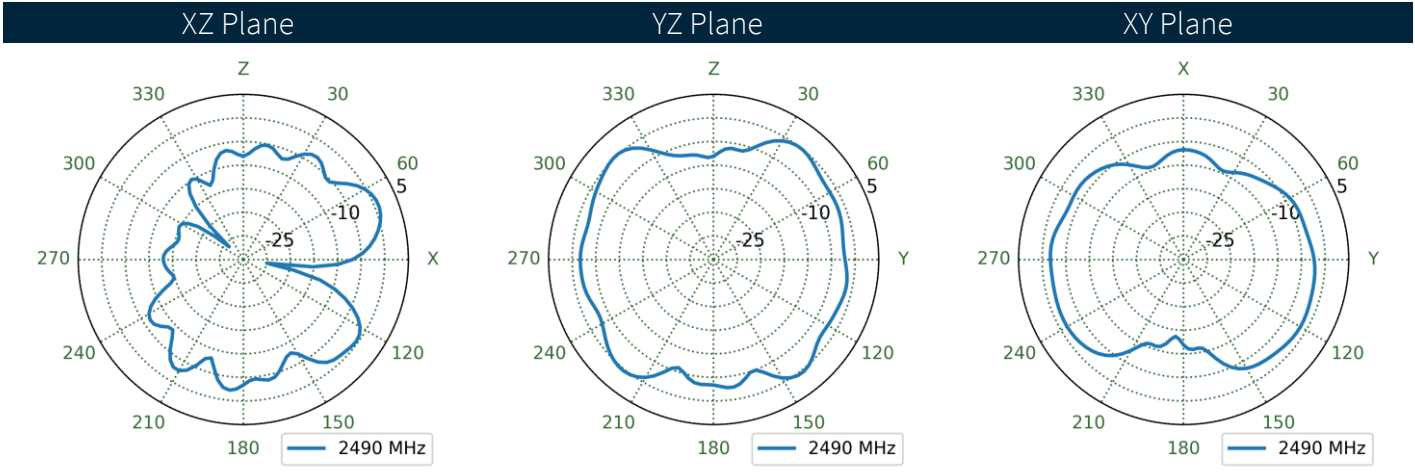
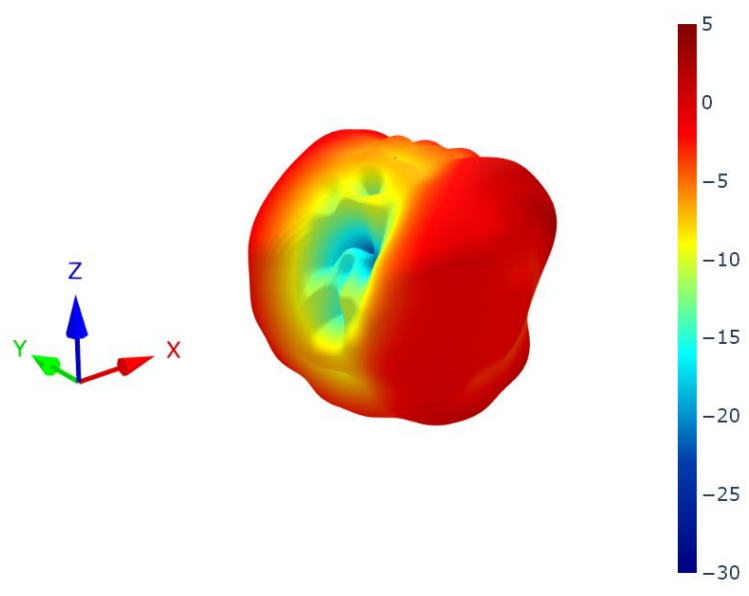

7.47 30x30cm Ground Plane Edge (Straight) Patterns at 2490 MHz

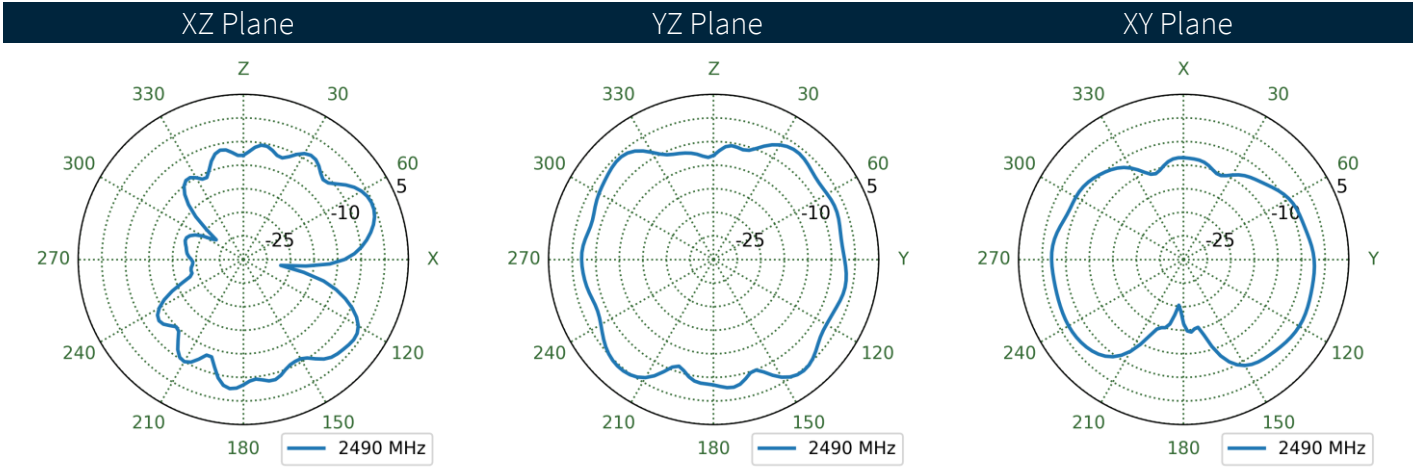
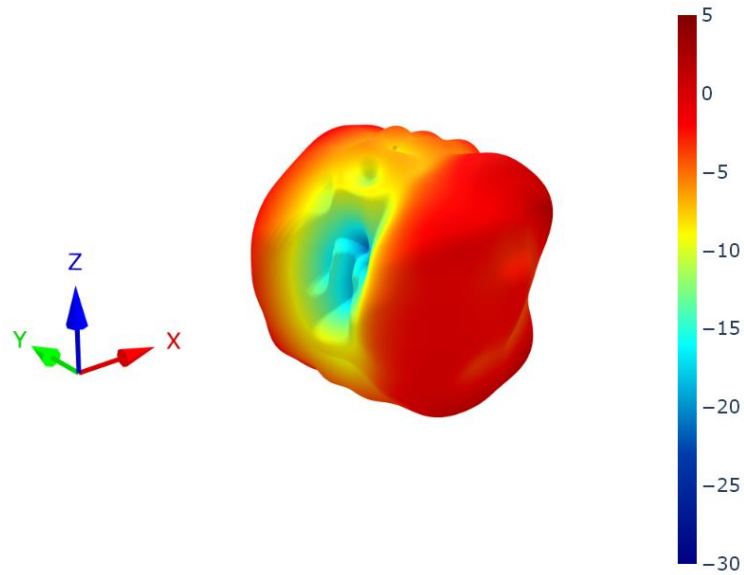

7.48 Free Space (Bent) Patterns at 2490 MHz

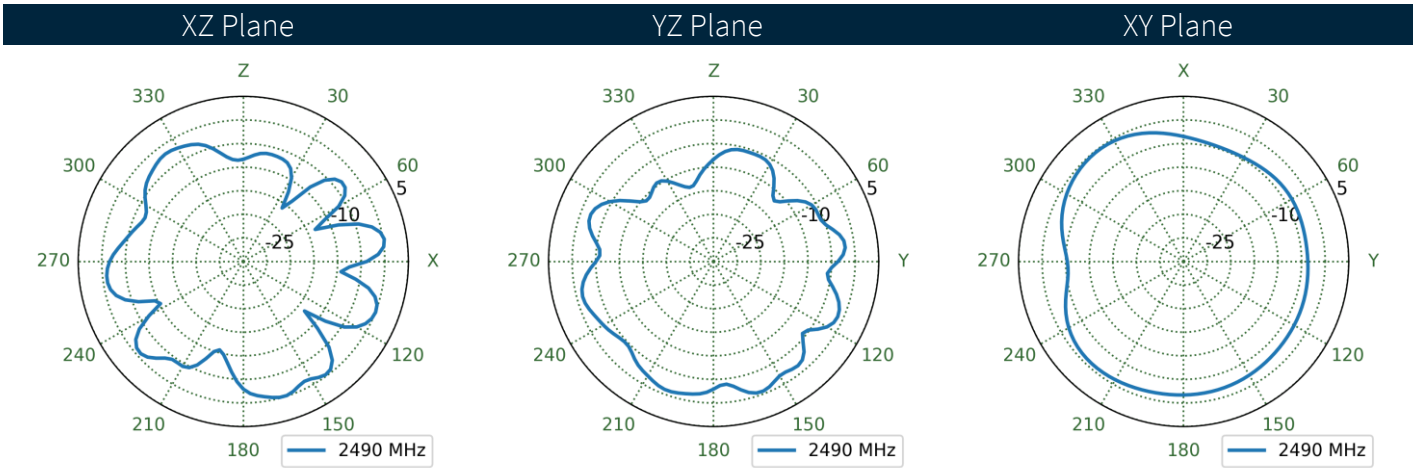
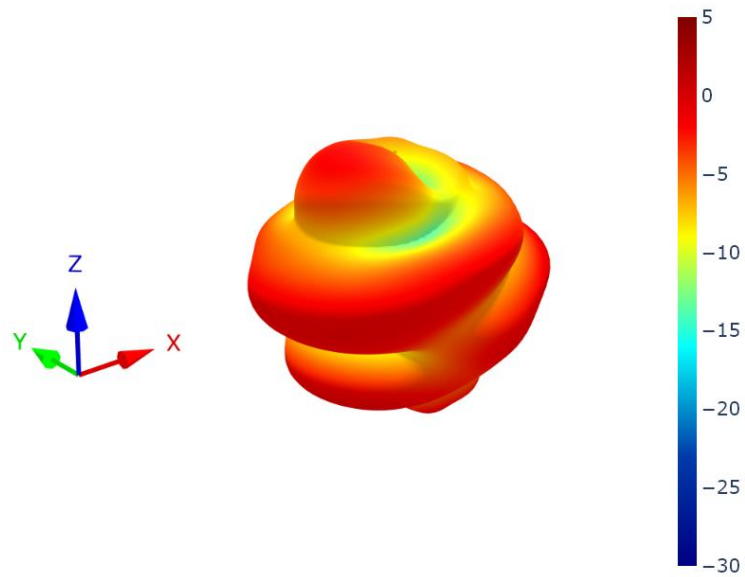

7.49 Free Space (Straight) Patterns at 2490 MHz

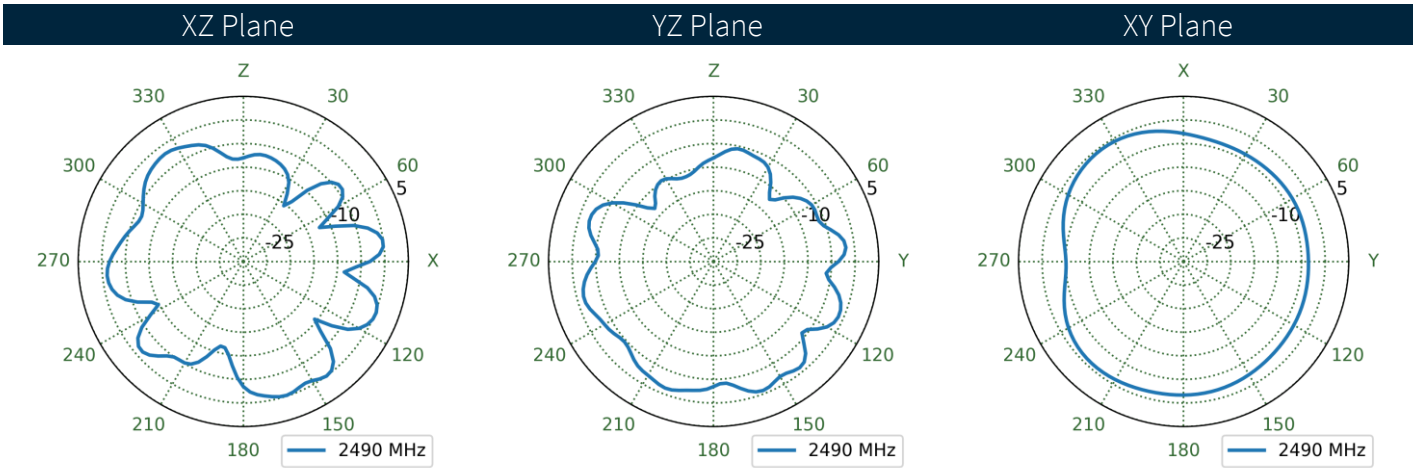
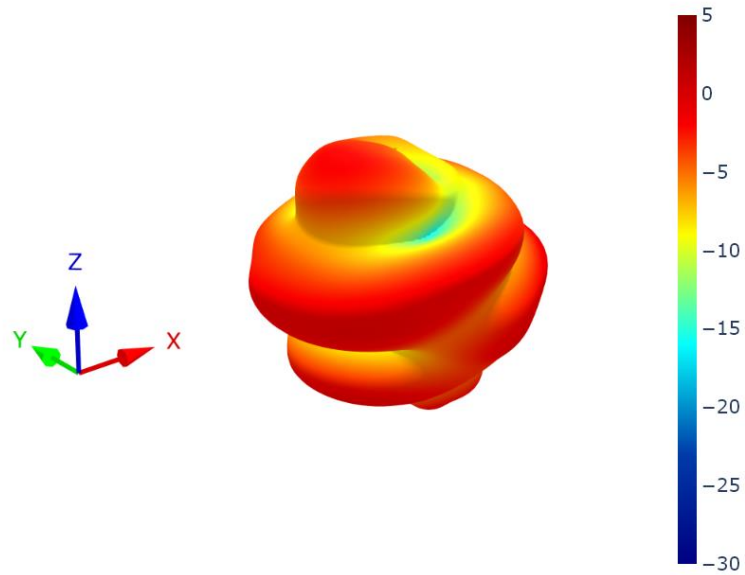

**7.50** 15x9cm Ground Plane (Bent) Patterns at 4150 MHz

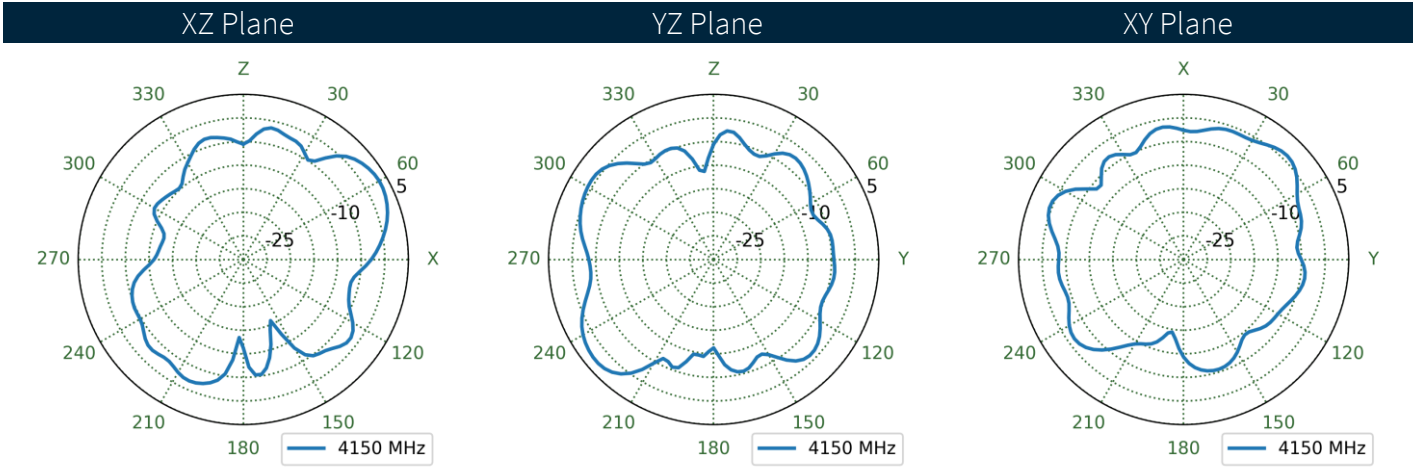
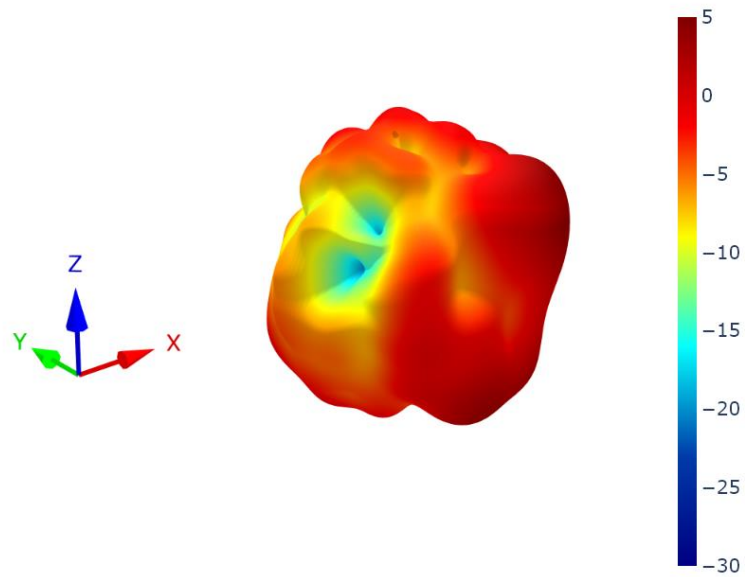

7.51 15x9cm Ground Plane (Straight) Patterns at 4150 MHz

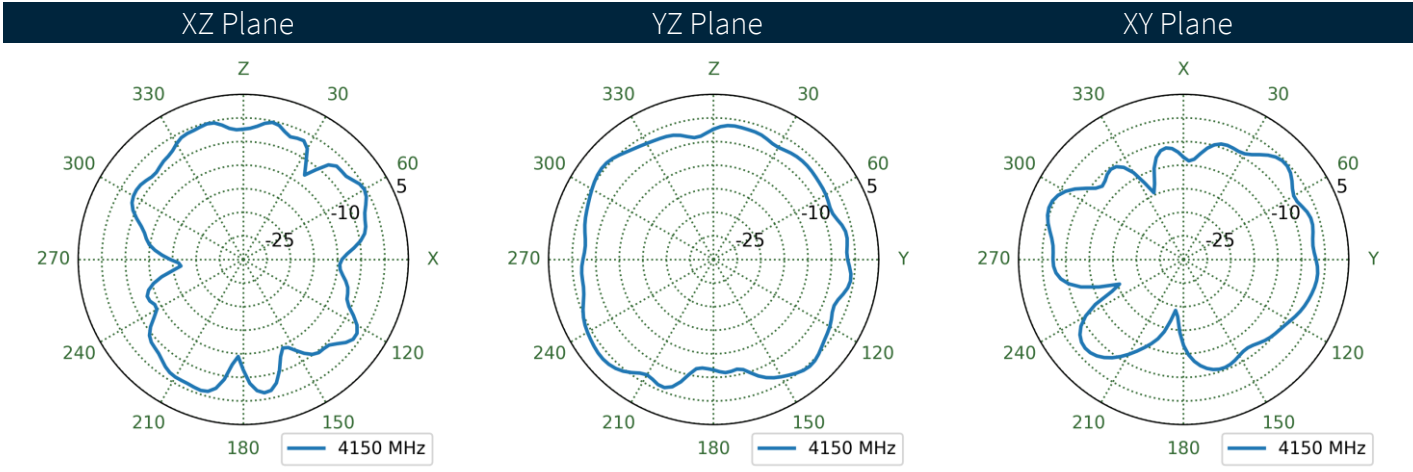
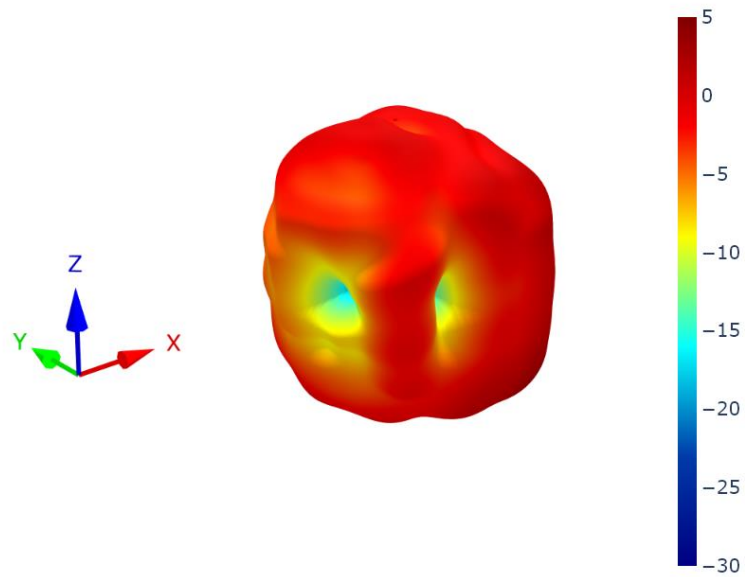

7.52 30x30cm Ground Plane Center (Bent) Patterns at 4150 MHz

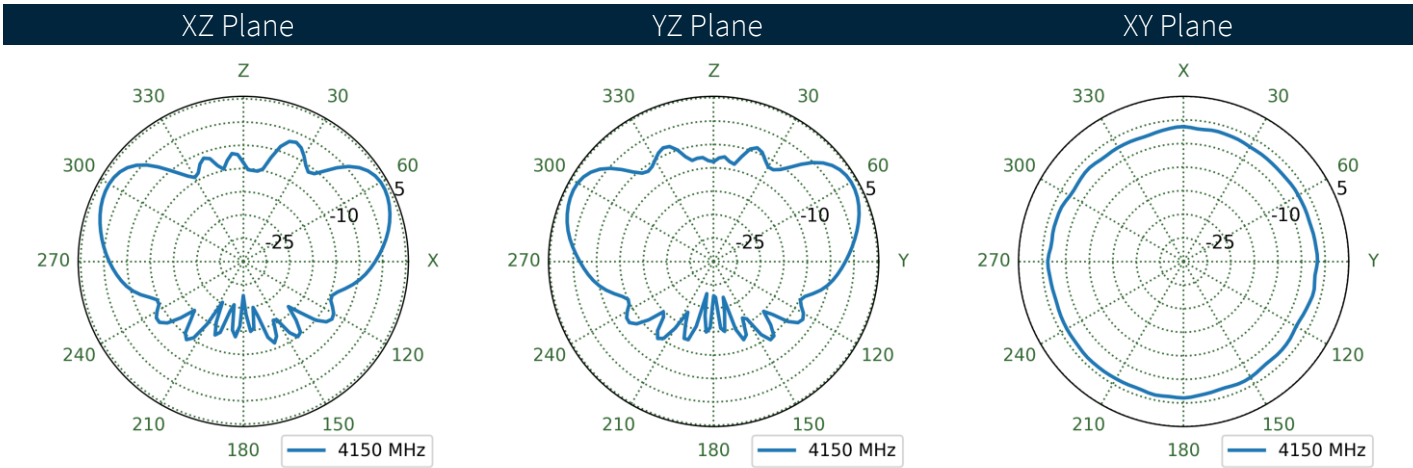
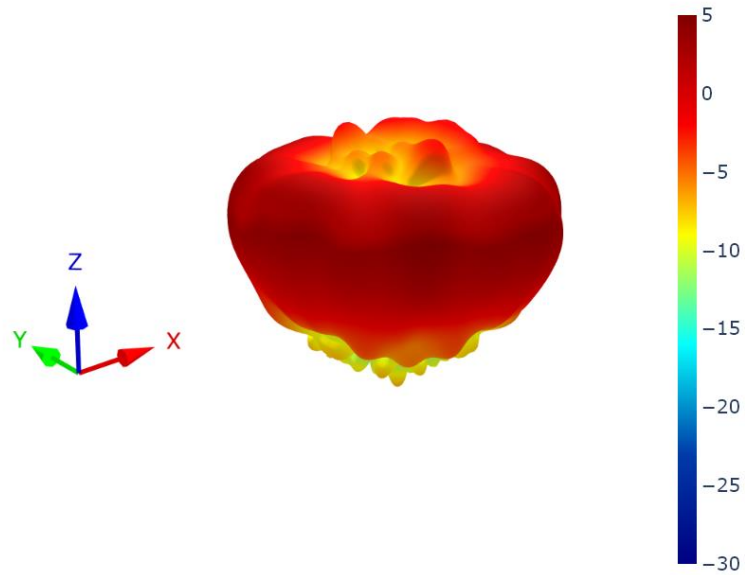



7.53 30x30cm Ground Plane Center (Straight) Patterns at 4150 MHz

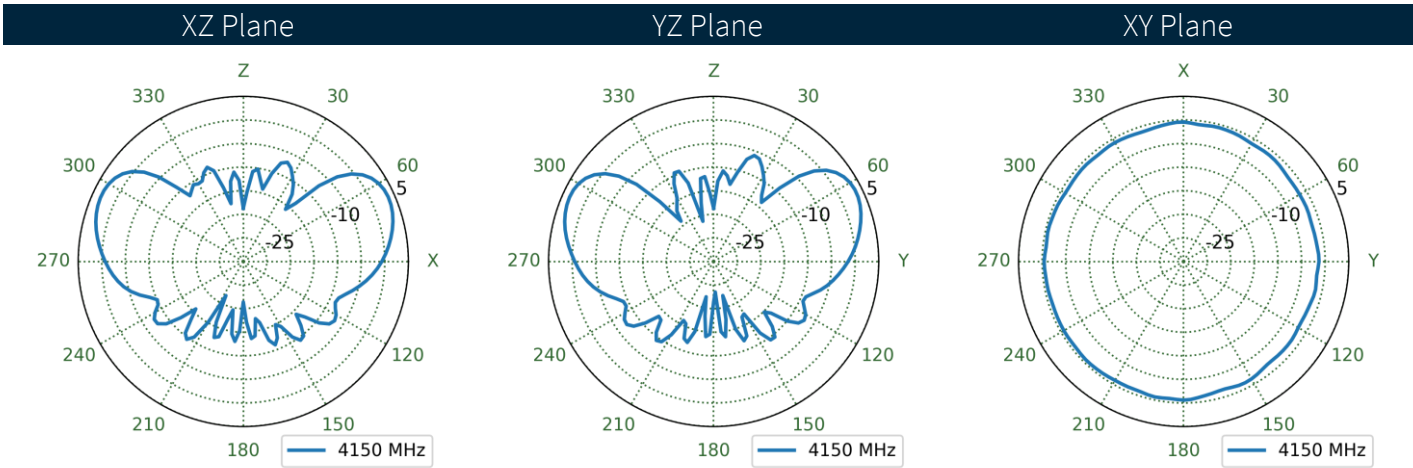
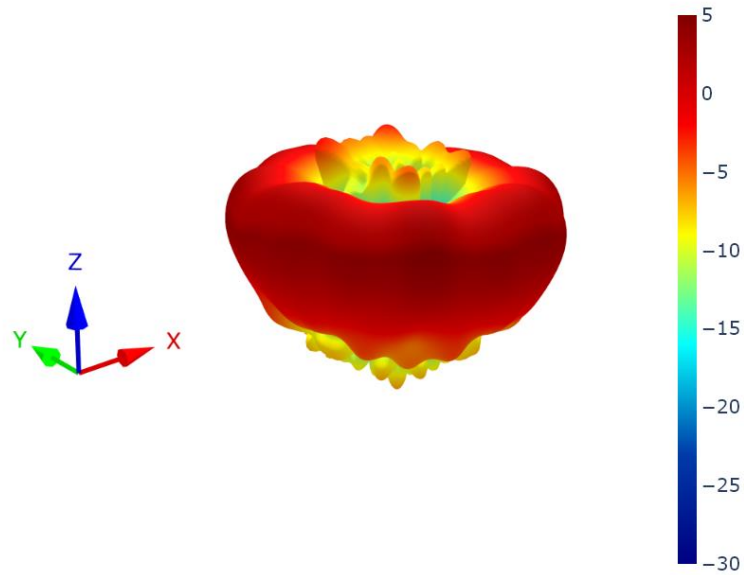

7.54 30x30cm Ground Plane Edge (Bent) Patterns at 4150 MHz

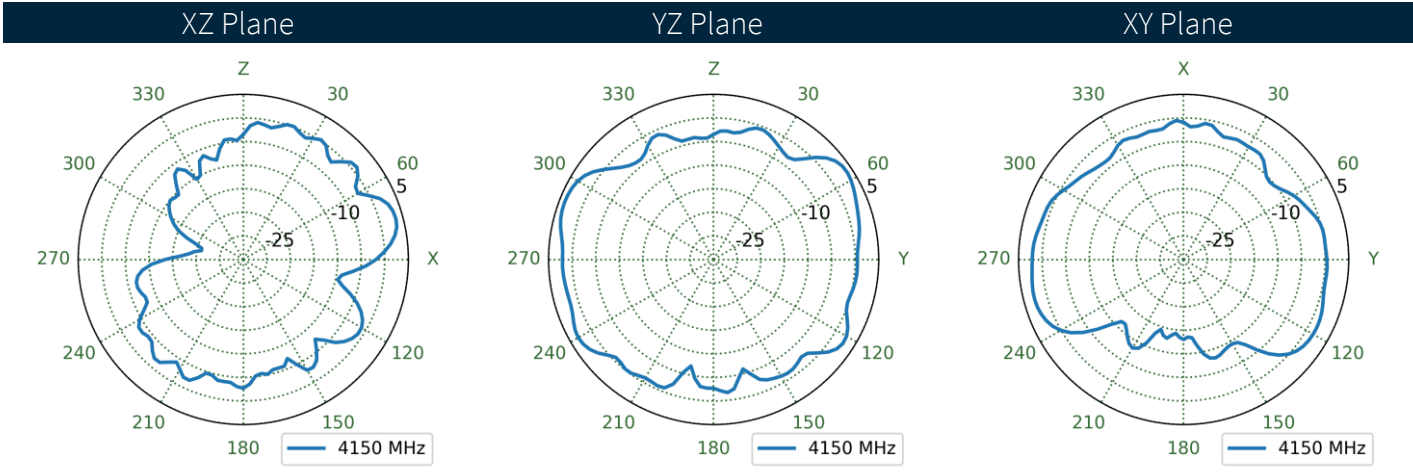
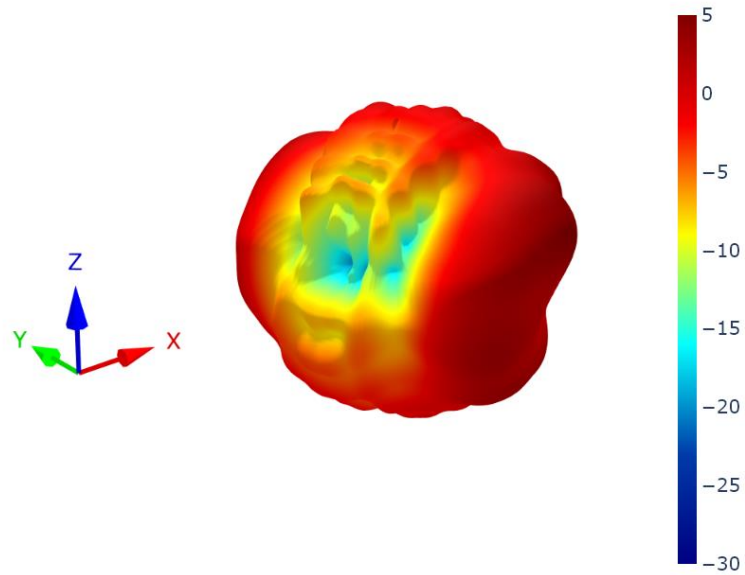

7.55 30x30cm Ground Plane Edge (Straight) Patterns at 4150 MHz

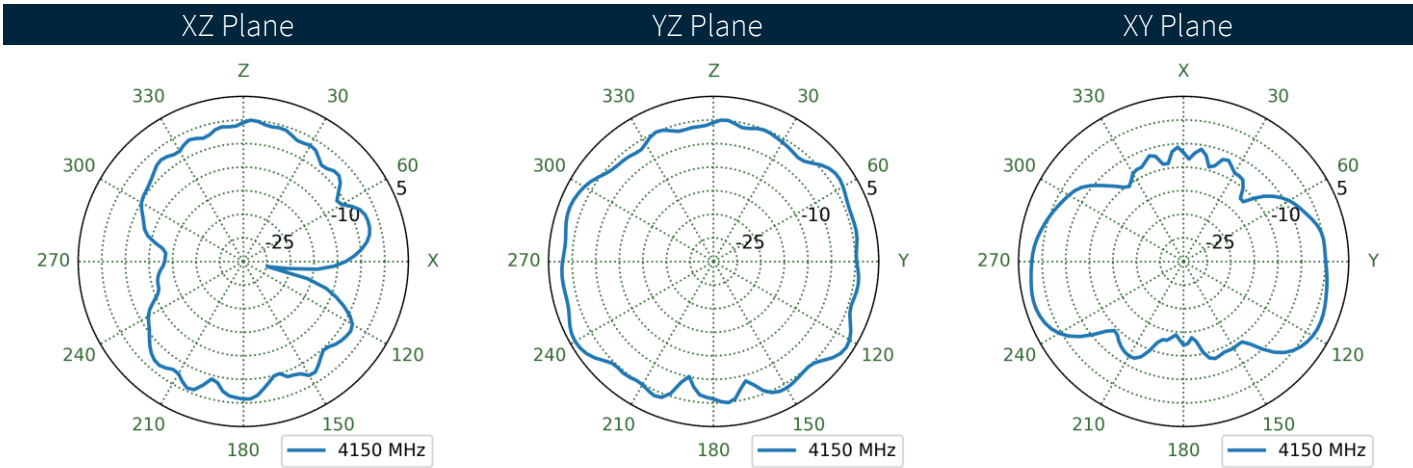
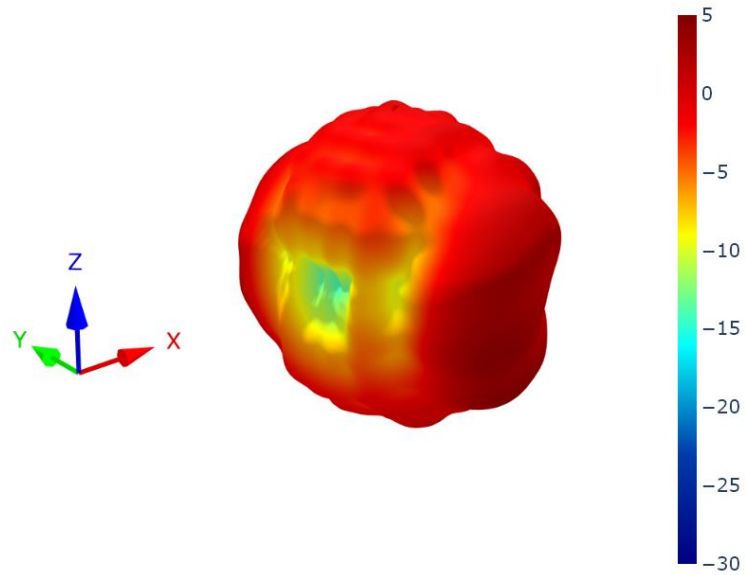

7.56 Free Space (Bent) Patterns at 4150 MHz

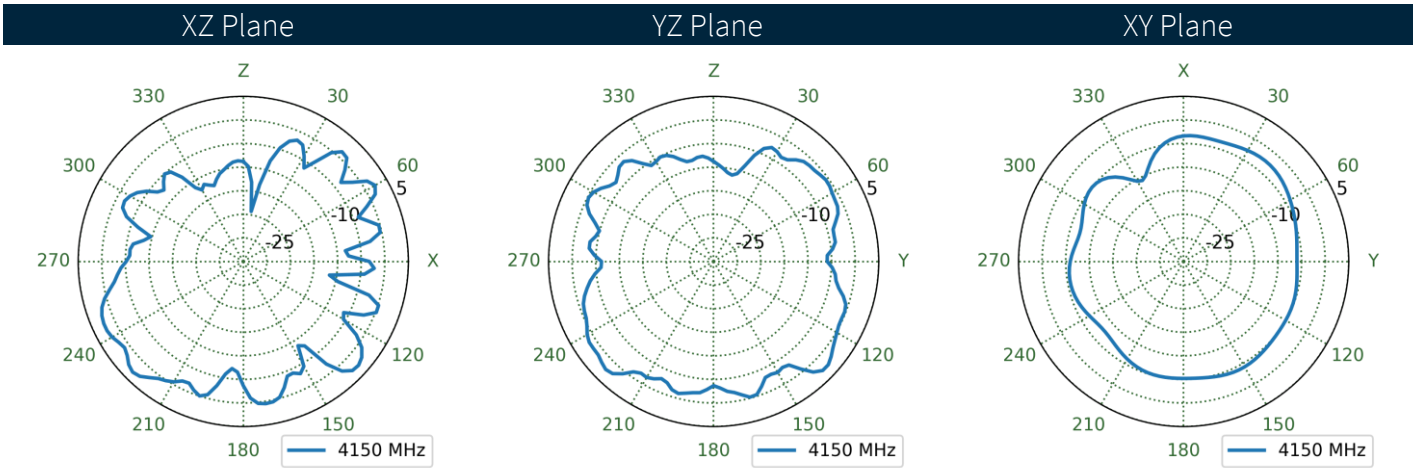
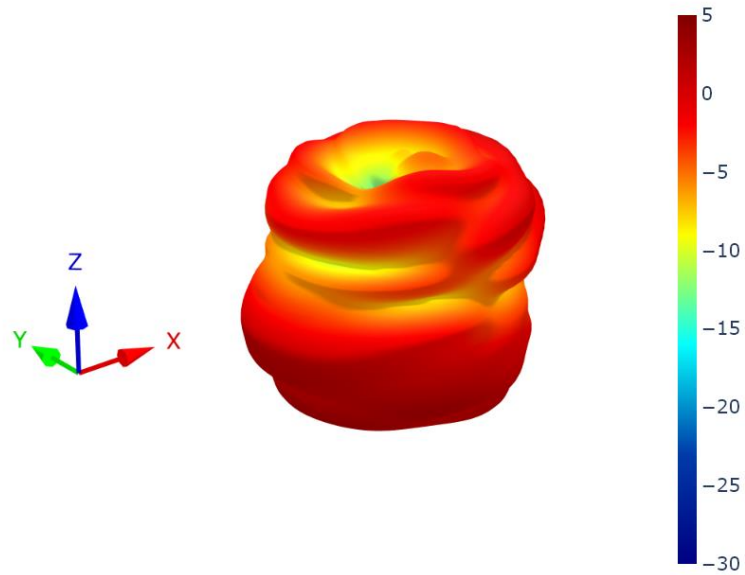

7.57 Free Space (Straight) Patterns at 4150 MHz

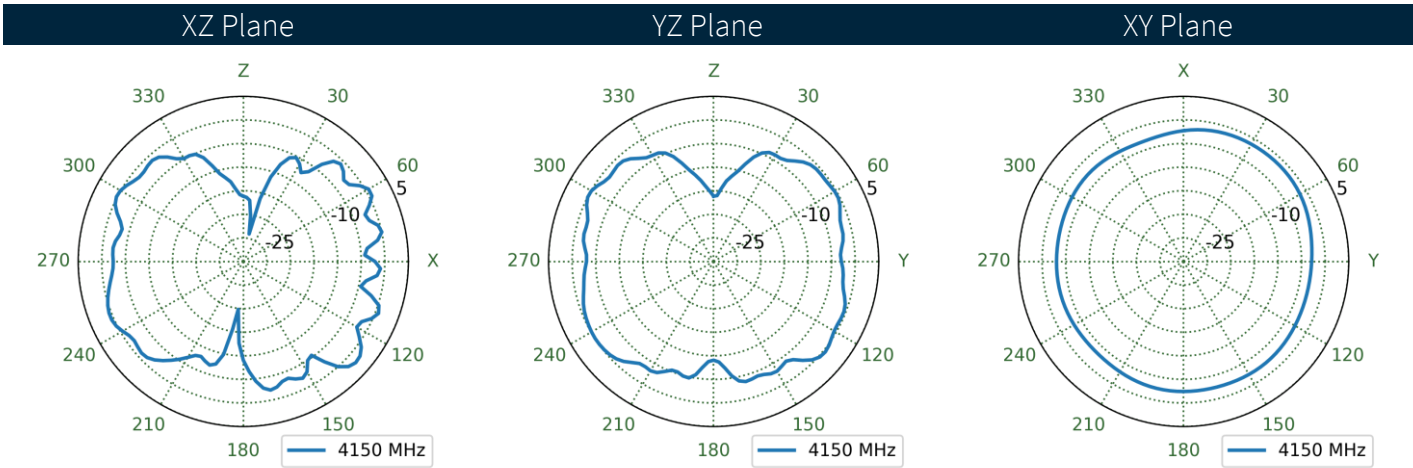
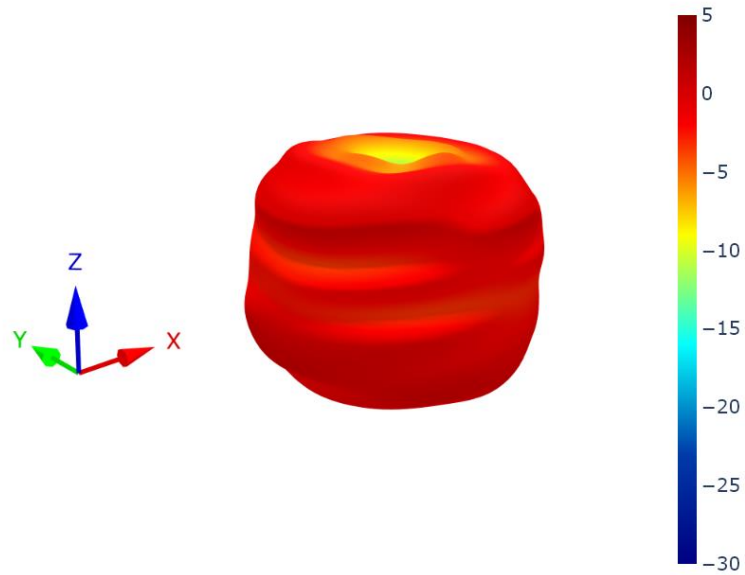

7.58 15x9cm Ground Plane (Bent) Patterns at 5540 MHz

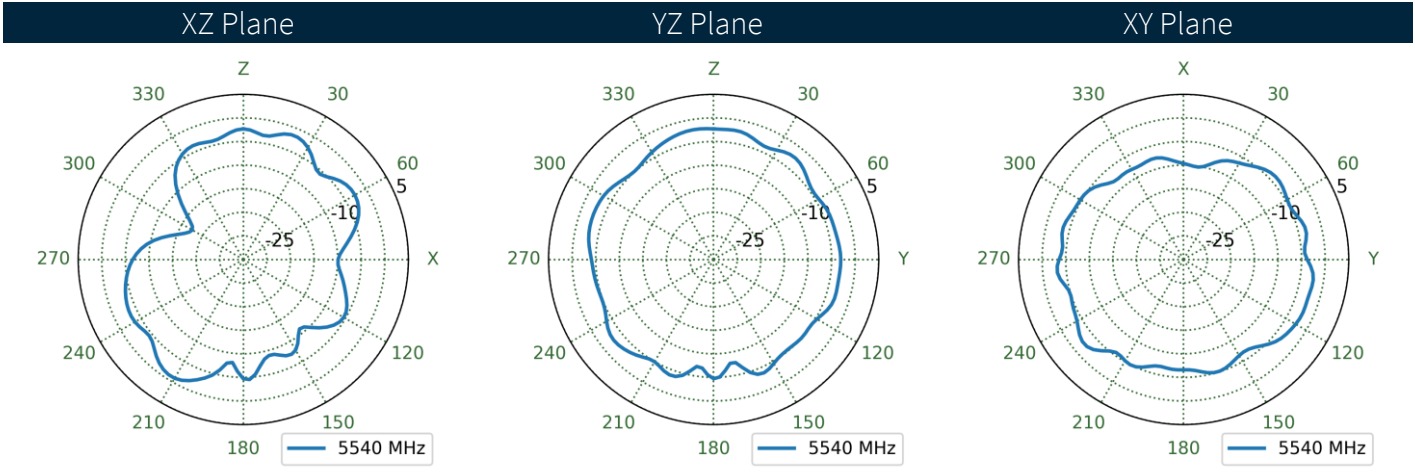
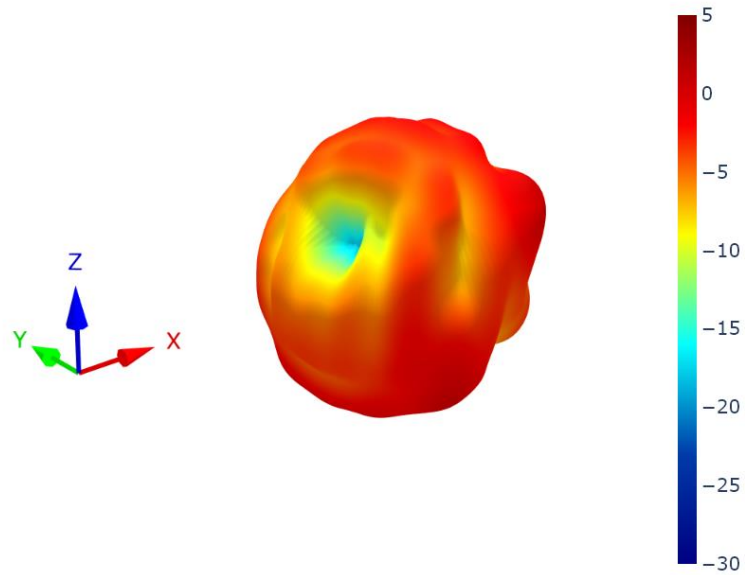

7.59 15x9cm Ground Plane (Straight) Patterns at 5540 MHz

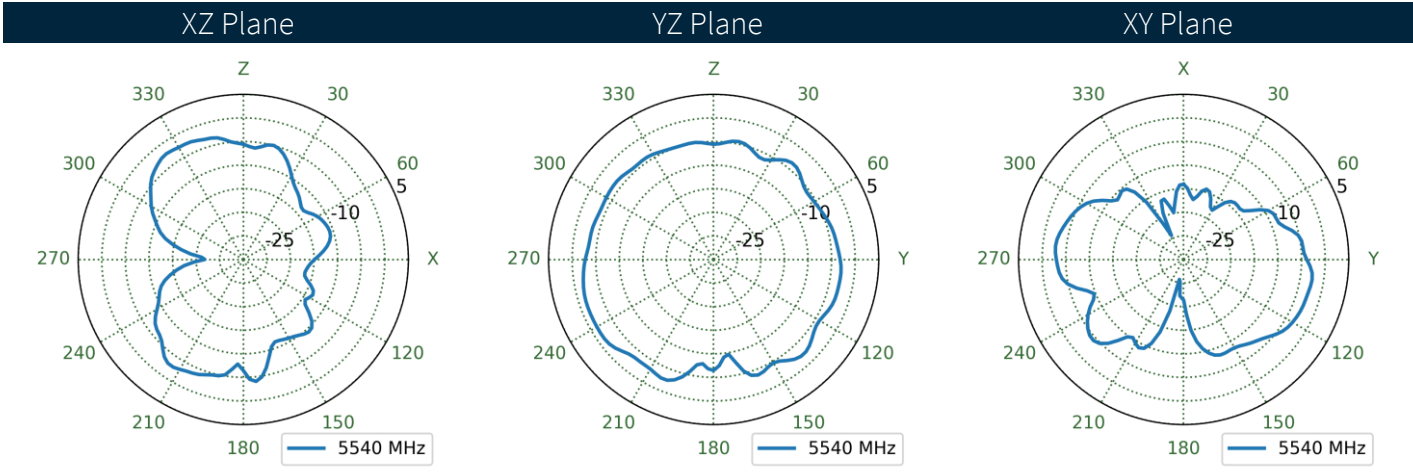
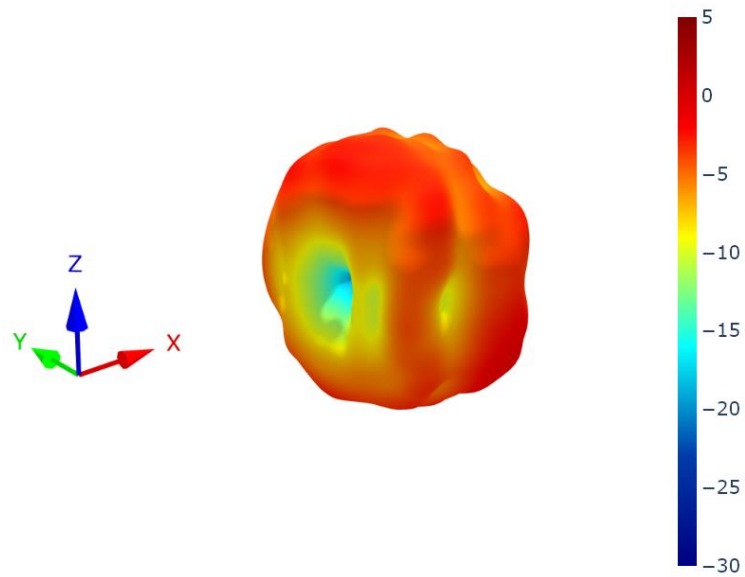

**7.60** 30x30cm Ground Plane Center (Bent) Patterns at 5540 MHz

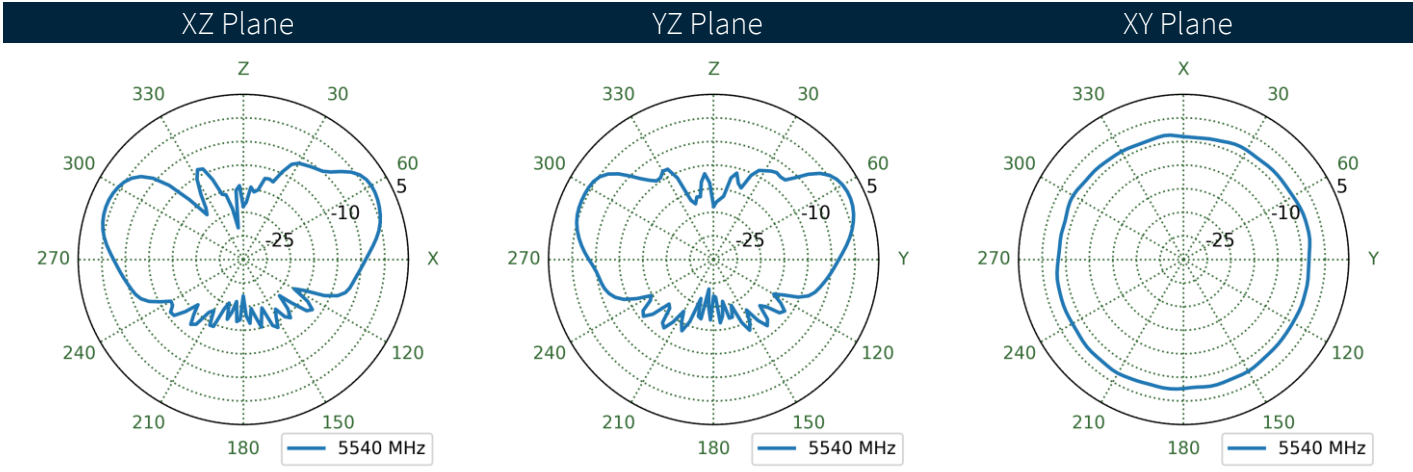
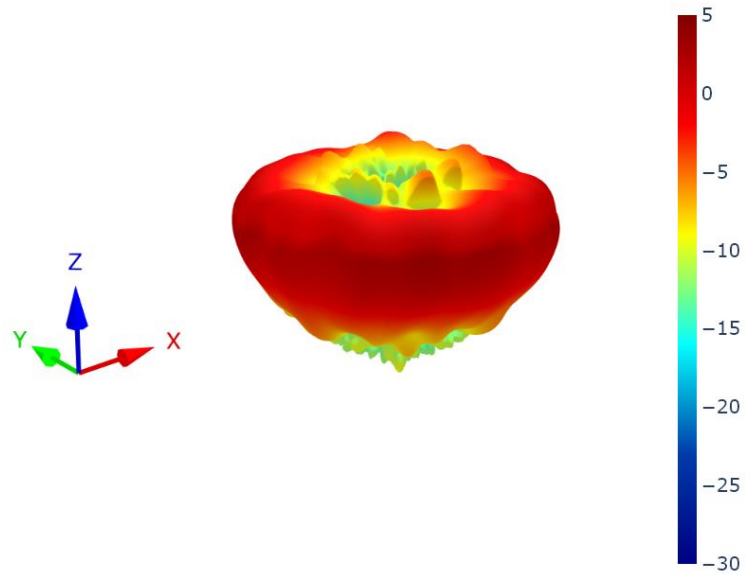



7.61 30x30cm Ground Plane Center (Straight) Patterns at 5540 MHz

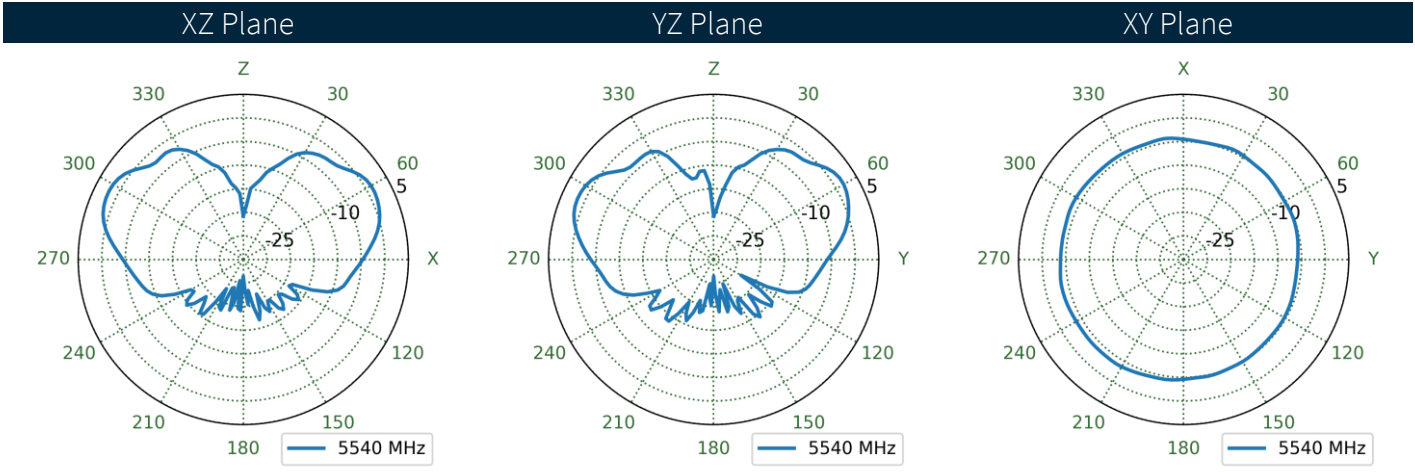
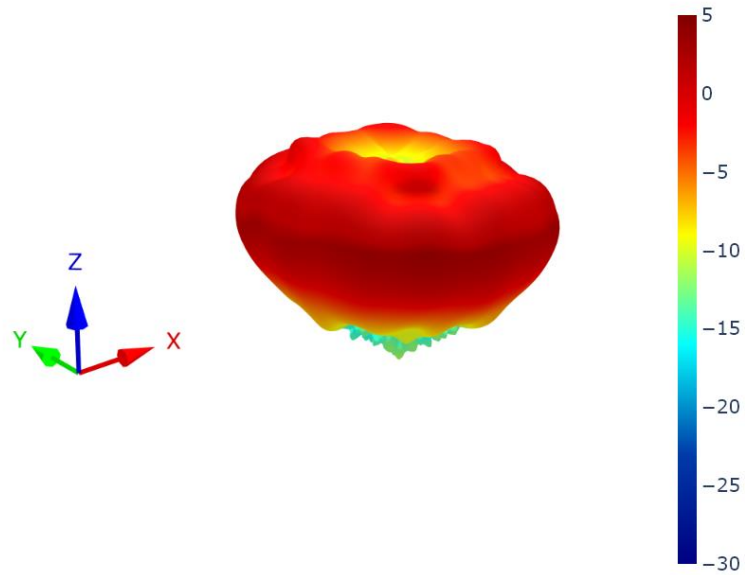

7.62 30x30cm Ground Plane Edge (Bent) Patterns at 5540 MHz

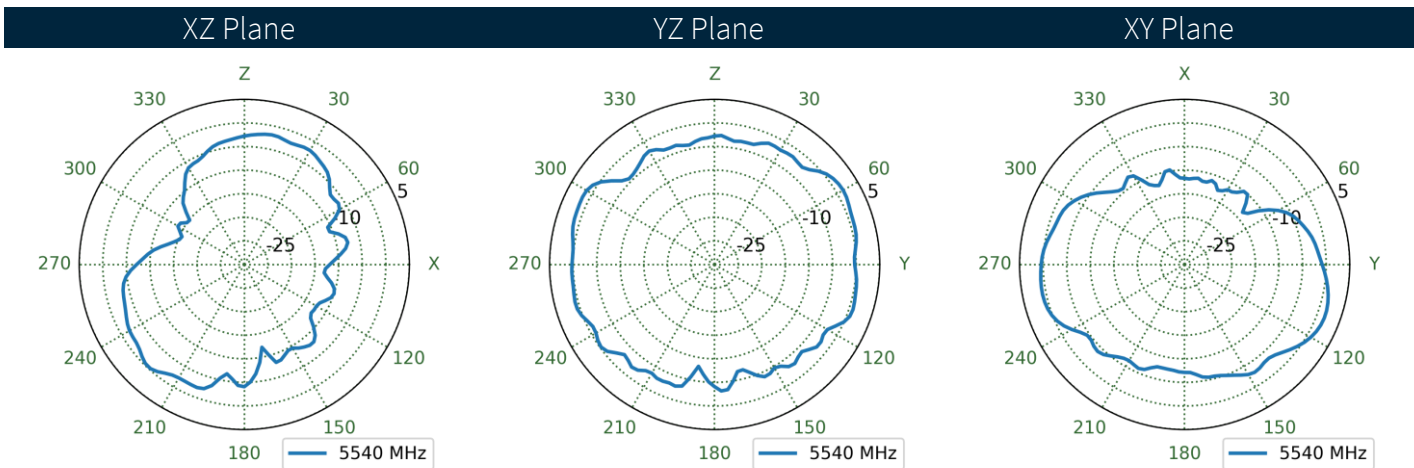
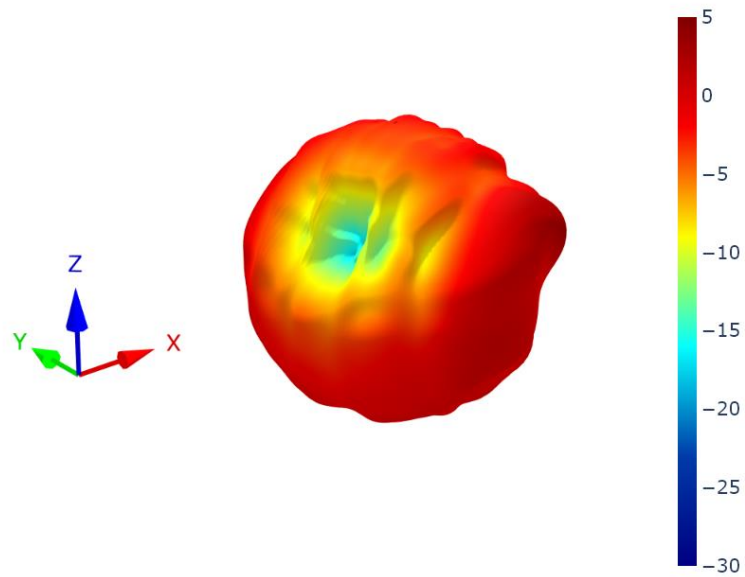

7.63 30x30cm Ground Plane Edge (Straight) Patterns at 5540 MHz

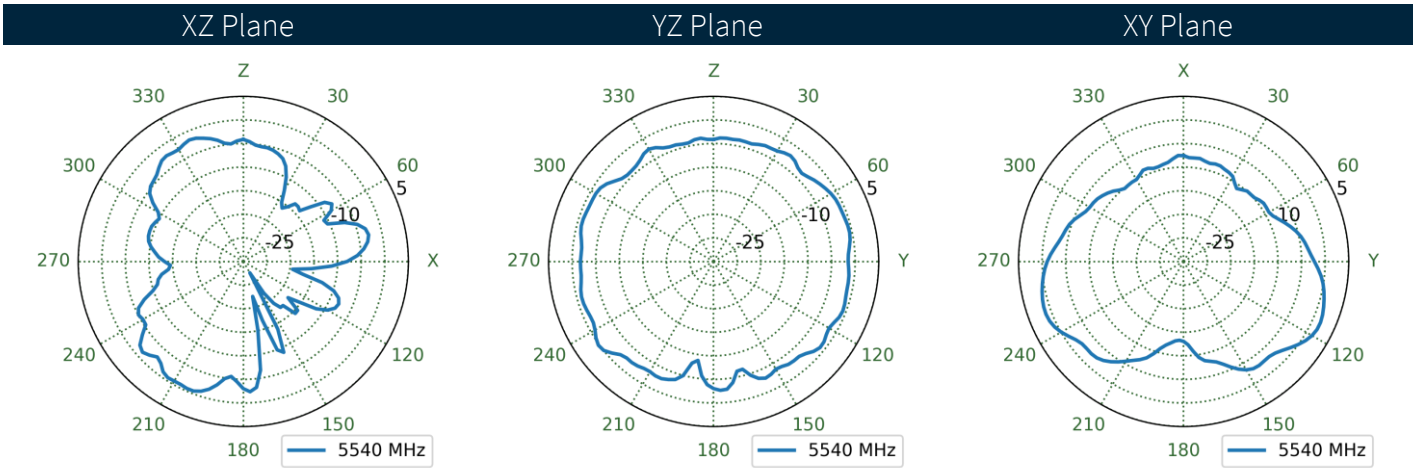
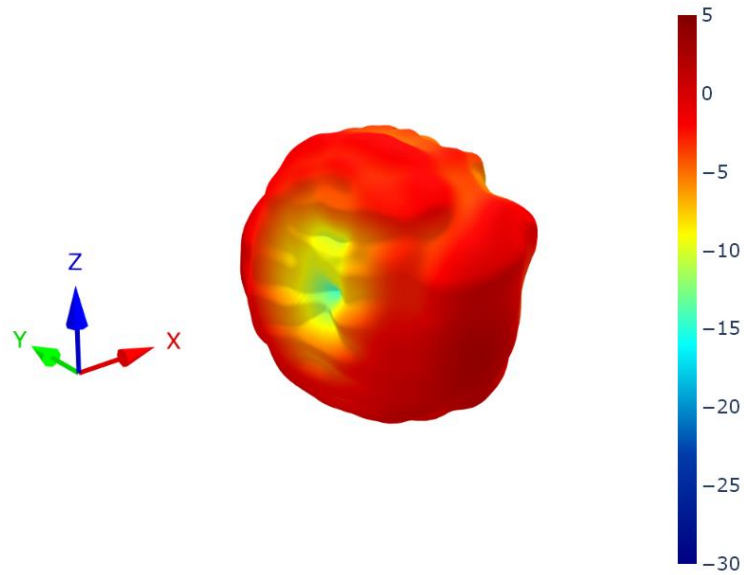

7.64 Free Space (Bent) Patterns at 5540 MHz

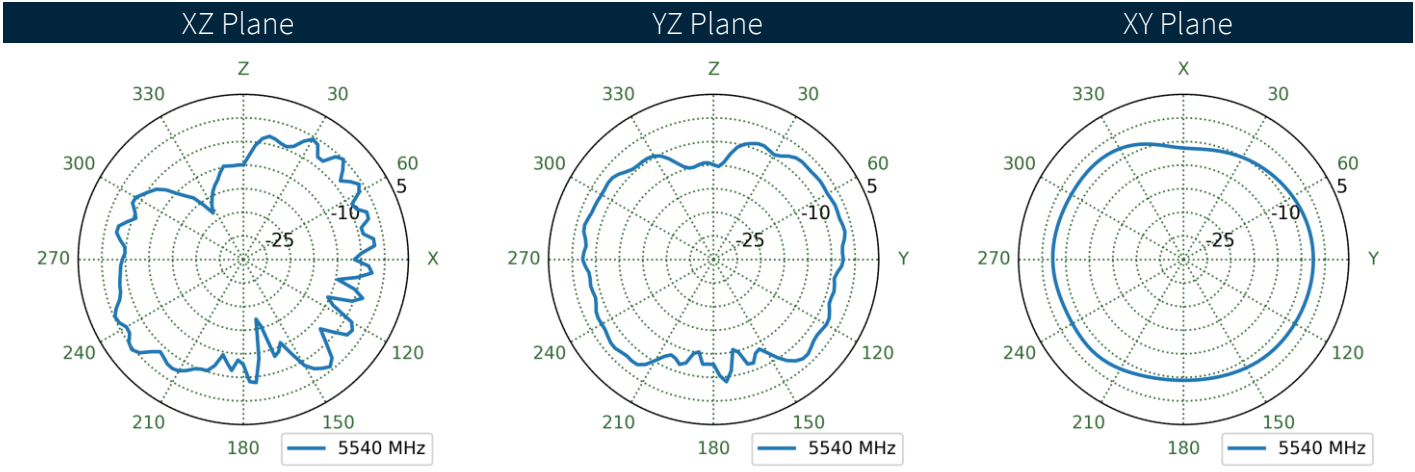
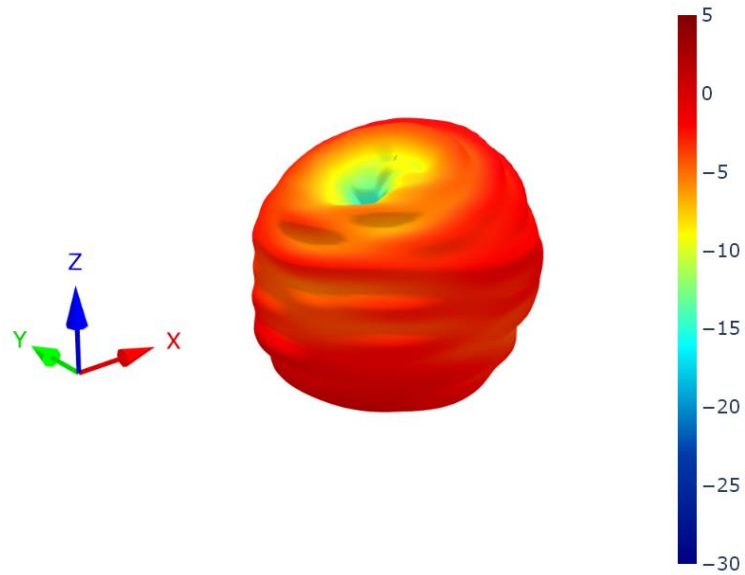

7.65 Free Space (Straight) Patterns at 5540 MHz

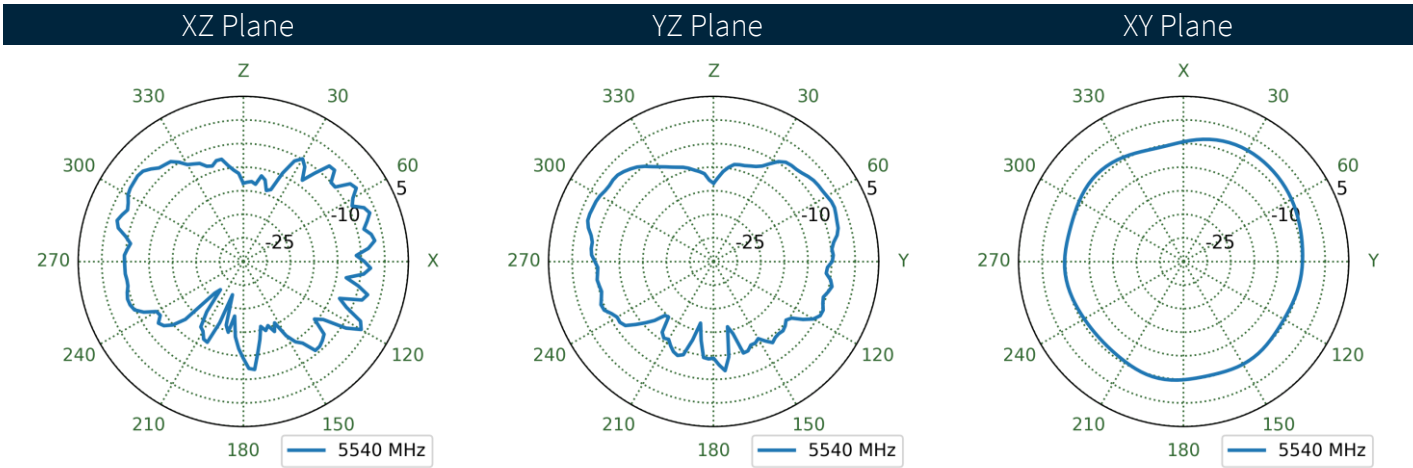
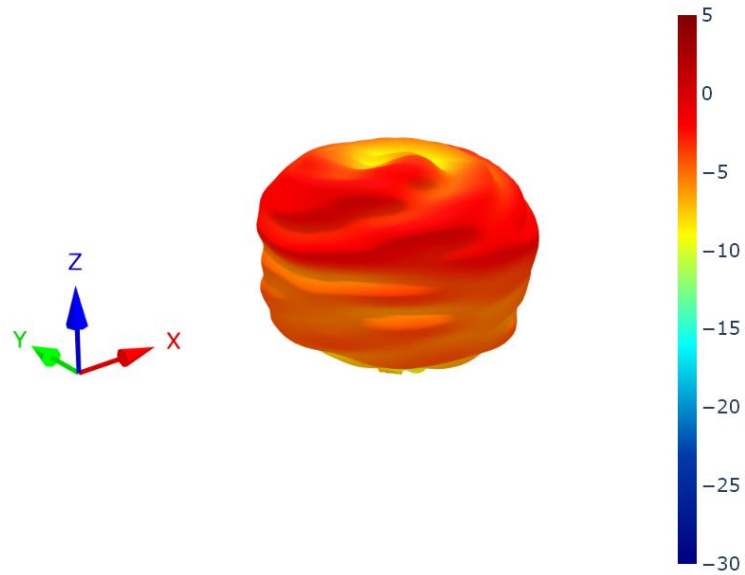

Changelog for the datasheet

**SPE-11-8-032 – TG.09.0113**

**Revision: O (Current Version)**

Date:	2025-03-10
Changes:	Full datasheet update.
Changes Made by:	Gary West

**Previous Revisions**

**Revision: N**

Date:	2020-04-08
Changes:	Updated Data, Packaging and Template
Changes Made by:	Jack Conroy

**Revision: I**

Date:	2014-03-08
Changes:	
Changes Made by:	Aine Doyle

**Revision: M**

Date:	2018-03-08
Changes:	Packaging Details Updated
Changes Made by:	Made by Andy Mahoney

**Revision: H**

Date:	2013-10-22
Changes:	Updated Intro
Changes Made by:	Aine Doyle

**Revision: L**

Date:	2017-02-23
Changes:	Intro Updated
Changes Made by:	Made by Andy Mahoney

**Revision: G**

Date:	2013-10-18
Changes:	LTE
Changes Made by:	Aine Doyle

**Revision: K**

Date:	2016-10-17
Changes:	Drawings Updated
Changes Made by:	Andy Mahoney

**Revision: F**

Date:	2012-06-19
Changes:	
Changes Made by:	Aine Doyle

**Revision: J**

Date:	2015-03-08
Changes:	
Changes Made by:	Aine Doyle

**Revision: E**

Date:	2011-08-05
Changes:	
Changes Made by:	Aine Doyle

**Previous Revisions (Continued)**

<table border="1"> <tr> <td colspan="2"><b>Revision: D</b></td> </tr> <tr> <td>Date:</td> <td>2011-07-11</td> </tr> <tr> <td>Changes:</td> <td></td> </tr> <tr> <td>Changes Made by:</td> <td>Aine Doyle</td> </tr> </table>	<b>Revision: D</b>		Date:	2011-07-11	Changes:		Changes Made by:	Aine Doyle	
<b>Revision: D</b>									
Date:	2011-07-11								
Changes:									
Changes Made by:	Aine Doyle								
<table border="1"> <tr> <td colspan="2"><b>Revision: C</b></td> </tr> <tr> <td>Date:</td> <td>2009-07-06</td> </tr> <tr> <td>Changes:</td> <td></td> </tr> <tr> <td>Changes Made by:</td> <td>Technical Writer</td> </tr> </table>	<b>Revision: C</b>		Date:	2009-07-06	Changes:		Changes Made by:	Technical Writer	
<b>Revision: C</b>									
Date:	2009-07-06								
Changes:									
Changes Made by:	Technical Writer								
<table border="1"> <tr> <td colspan="2"><b>Revision: B</b></td> </tr> <tr> <td>Date:</td> <td>2009-06-09</td> </tr> <tr> <td>Changes:</td> <td>Packaging Details Updated</td> </tr> <tr> <td>Changes Made by:</td> <td>Technical Writer</td> </tr> </table>	<b>Revision: B</b>		Date:	2009-06-09	Changes:	Packaging Details Updated	Changes Made by:	Technical Writer	
<b>Revision: B</b>									
Date:	2009-06-09								
Changes:	Packaging Details Updated								
Changes Made by:	Technical Writer								
<table border="1"> <tr> <td colspan="2"><b>Revision: A (Original First Release)</b></td> </tr> <tr> <td>Date:</td> <td>2009-01-09</td> </tr> <tr> <td>Notes:</td> <td></td> </tr> <tr> <td>Author:</td> <td>Technical Writer</td> </tr> </table>	<b>Revision: A (Original First Release)</b>		Date:	2009-01-09	Notes:		Author:	Technical Writer	
<b>Revision: A (Original First Release)</b>									
Date:	2009-01-09								
Notes:									
Author:	Technical Writer								



[www.taoglas.com](http://www.taoglas.com)

