

Installation Manual

NavNet TZtouchE

Model TZT9E/TZT13E

(Product Name: MULTI FUNCTION DISPLAY)

SAFETY INSTRUCTIONS	i
SYSTEM CONFIGURATION	iii
EQUIPMENT LISTS.....	v
1. MOUNTING.....	1-1
1.1 Installation of Multi Function Display.....	1-1
1.2 Flush Mounting	1-2
1.3 Desktop Mounting	1-5
1.4 Installation of Transducers.....	1-7
1.5 Sensors (Option).....	1-17
2. WIRING.....	2-1
2.1 Interface Connections	2-1
2.2 Power Cable	2-3
2.3 Grounding Wire.....	2-3
2.4 NMEA 0183 Connection (TX Only).....	2-4
2.5 DRS Radar Sensor Connections	2-5
2.6 Network Connection with Other TZT Series Units	2-5
2.7 NMEA 2000 Connection	2-5
2.8 Example of TZT9E/13E System Configuration	2-10
2.9 SUZUKI Outboard Motor Connection	2-11
3. HOW TO SET UP THE EQUIPMENT.....	3-1
3.1 How to Manage Device Communication.....	3-4
3.2 How to Set Time Zone, Time Format and Language.....	3-5
3.3 How to Set Units of Measurement	3-6
3.4 Initial Setup	3-7
3.5 How to Set Up the Radar (For the service technician only).....	3-13
3.6 How to Set Up the Fish Finder.....	3-16
3.7 Wireless LAN Setting.....	3-23
3.8 How to Manage Charts	3-24
3.9 How to Set Up the SUZUKI Engine	3-30
APPX. 1 TRANSDUCER INSTALLATION GUIDE	AP-1
APPX. 2 INSTALLATION OF TEMPERATURE SENSORS.....	AP-12
APPX. 3 TRANSDUCER LIST	AP-17
OUTLINE DRAWING(S).....	D-1





FURUNO ELECTRIC CO., LTD.

www.furuno.com



SAFETY INSTRUCTIONS

Follow the safety instructions listed below and throughout this manual to prevent damage to your equipment or vessel and to prevent harm to the operator or other personnel on-board. The results of failing to follow the instructions and guidelines outlined herein are listed below.

 WARNING	Indicates a potentially hazardous situation which, if not avoided, could result in death or serious injury.
 CAUTION	Indicates a potentially hazardous situation which, if not avoided, may result in minor or moderate injury.

(Examples of symbols)



Warning, Caution



Prohibitive Action



Mandatory Action

 WARNING	
	ELECTRICAL SHOCK HAZARD Do not open the equipment unless totally familiar with electrical circuits. Only qualified technician should work inside the equipment.
	Turn off the power at the switchboard before beginning the installation. Fire or electrical shock can result if the power is left on.
	Be sure that the power supply is compatible with the voltage rating of the equipment. Connection of an incorrect power supply can cause fire or damage the equipment.
	If your vessel is configured with an autopilot system, install an autopilot control unit (or emergency autopilot stop button) at each helm station, to allow you to disable the autopilot in an emergency. If the autopilot cannot be disabled, accidents may result.

	Ground the equipment to prevent electrical shock and mutual interference.
	Use the proper fuse. Use of an incorrect fuse may damage the equipment.
	The front panel is made of glass. Handle it with care. Injury can result if the glass breaks.
	A magnetic compass may receive interference if it is placed too close to the TZT9E/13E. Observe the compass safe distances to prevent interference to a magnetic compass.
	Be sure to attach caps to all unused connectors. The unit may be damaged. Electrical shock can result.
	Do not connect/disconnect the cables connected to the unit while the power is turned on. The unit may be damaged.

WARNING



The radar antenna sends electromagnetic radio frequency (RF) energy. This energy can be dangerous to you, especially your eyes. Do not look at the radiator or near the antenna when the antenna is rotating.

The distances at which RF radiation levels of 100 W/m² and 10 W/m² exist are shown in the table.

Antenna Model	Distance to 100 W/m ² point	Distance to 10 W/m ² point
DRS2D-NXT	N/A	0.7 m
DRS4D-NXT	N/A	0.7 m
DRS4DL+	N/A	0.9 m
DRS6A X-Class (XN12A)	N/A	2.2 m
DRS6A X-Class (XN13A)	N/A	1.9 m
DRS12A X-Class (XN12A)	0.3 m	3.1 m
DRS12A X-Class (XN13A)	0.2 m	2.9 m
DRS25A X-Class (XN12A)	0.8 m	7.7 m
DRS25A X-Class (XN13A)	0.7 m	6.8 m

Antenna Model	Distance to 100 W/m ² point	Distance to 10 W/m ² point
DRS6A-NXT (XN10A)	N/A	0.6 m
DRS6A-NXT (XN12A)	N/A	0.6 m
DRS6A-NXT (XN13A)	N/A	0.4 m
DRS12A-NXT (XN12A)	0.2 m	1.9 m
DRS12A-NXT (XN13A)	0.15 m	1.8 m
DRS25A-NXT (XN12A)	0.3 m	2.8 m
DRS25A-NXT (XN13A)	0.2 m	2.65 m
DRS4D X-Class	0.53 m	1.7 m
DRS4DL X-Class	N/A	0.73 m



Check that no person is near the open-type radar antenna before you turn on the radar.

Serious injury or death can occur if a person is hit by a rotating radar antenna.

About the TFT LCD

The TFT LCD is constructed using the latest LCD techniques, and displays 99.99% of its pixels. The remaining 0.01% of the pixels may drop out or are constantly lit. Additionally, the LCD has a limited viewing angle and may flicker. However, these are not indications of malfunction.

SYSTEM CONFIGURATION

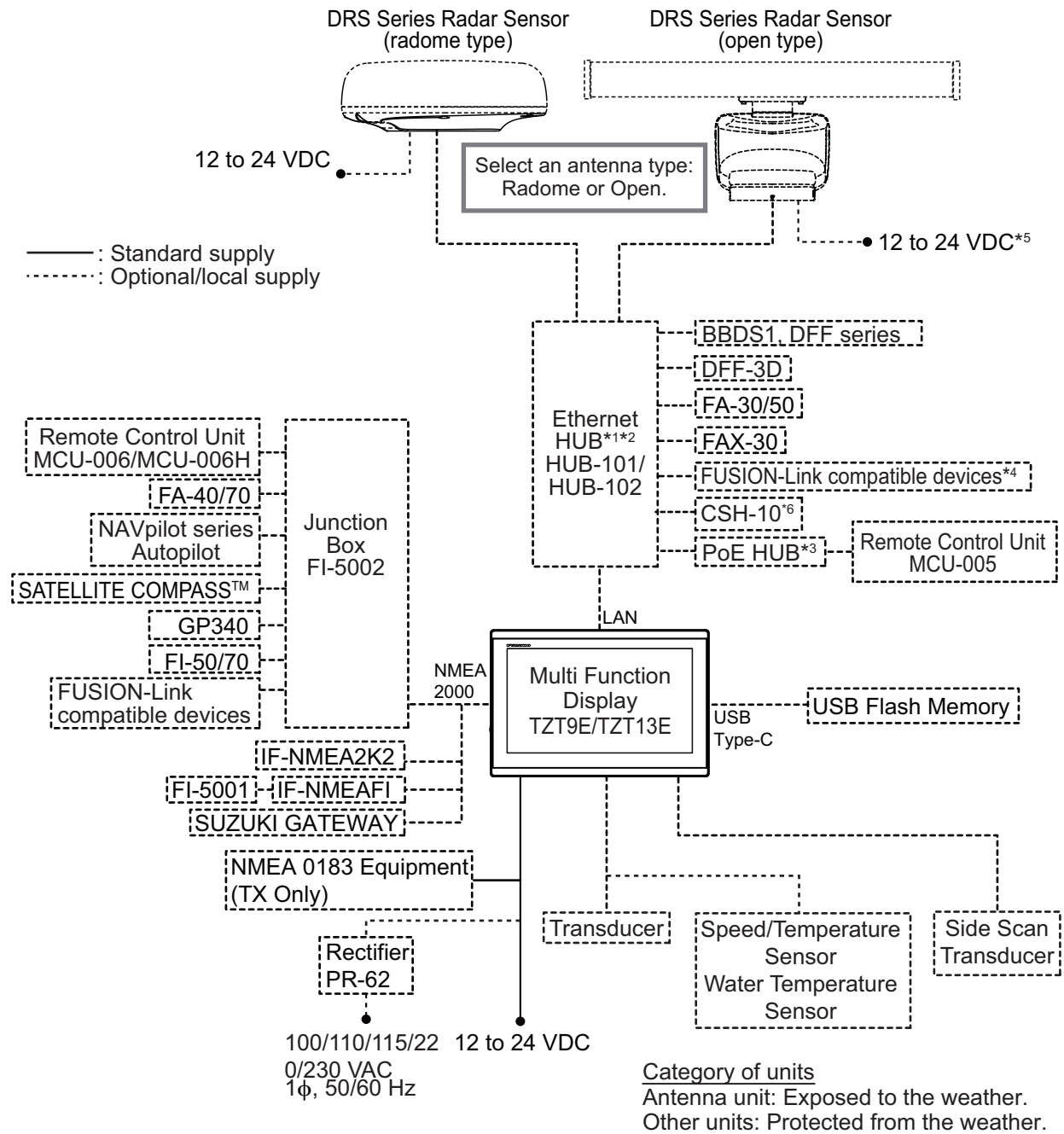

*1: For the multi-stage (cascade) connection, a maximum of four units of HUB-101/HUB-102 can be connected to the MFDs.

*2: With the Ethernet HUB, up to six NavNet TZtouch series units can be connected (up to four units when the TZT2BB is included). NavNet TZtouch (TZT9/14/BB) and TZTL12F/15F of NavNet TZtouch2 cannot be connected. For connection combinations, see "TZT series network connections" at the end of this chapter for details.

*3: Use a commercially available PoE HUB. The NETGEAR GS108PE has tested as compatible. The basic functions of the hub were verified, however the compatibility of all functions were not checked. FURUNO cannot guarantee proper operation.

*4: Available when FUSION-Link compatible equipment is connected via Ethernet.

*5: 12 VDC is only used with DRS6A-NXT. All other open array DRS sensors require 24 VDC.

*6: The software version of the CSH-10 must be "Ver. 01.02" or later.

TZT series network connections

The TZT series can be connected on the same network in the following combinations.

	TZtouch: TZT9/14/BB	TZtouch2: TZTL12F/15F	TZtouch2: TZT2BB^{*1}	TZtouch3: TZT9F/12F/ 16F/19F^{*2}	TZtouchXL TZT10X/13X/16X/ 22X/24X/BBX^{*3}
TZtouchE: TZT9E/13E	No	No	Yes	Yes	Yes

^{*1}: Available in the future (from version 9.9).

^{*2}: Available in the future (from version 3.9).

^{*3}: Available in the future (from version 26.11).

EQUIPMENT LISTS

Standard supply

Name	Type	Qty
TZT9E		
Multi Function Display	TZT9E	1
Chart SD Card	—	1
Protective Cover	HPC53AX	1
Knob	—	2
External Bracket	HBS53BX	1
Cleaning Cloth	MINUCLOTH-GREY	1
Power Cable	CBC0FS0900	1
Pin Label	—	1
Flush Mount Screws Kit	K12CS1007A	1
Flush Mount Gasket	HGB15AX	1
External Bracket Fixing Screws	VTATM4.8x22TCCAUTINX	4
Network (LAN) Cable	FRU-RZWPNWP-005G	1
Waterproof RJ45 (M) To RJ45 Adapter CBL .5M	FUSA-RPZG5E-A	1
TZT13E		
Multi Function Display	TZT13E	1
Screw Cover	—	2
Chart SD Card	—	1
Protective Cover	—	1
Knob	—	2
External Bracket	—	1
Cleaning Cloth	MINUCLOTH-GREY	1
Power Cable	CBC0FS0900	1
Pin Label	—	1
Flush Mount Screws	M4.2x25 (#8x1")	8
Flush Mount Gasket	—	1
External Bracket Fixing Screws	VTATM4.8x22TCCAUTINX	4
Network (LAN) Cable	FRU-RZWPNWP-005G	1
Waterproof RJ45 (M) To RJ45 Adapter CBL .5M	FUSA-RPZG5E-A	1

Optional supply

Name	Type	Remarks
NMEA Data Converter	IF-NMEA2K2	
Remote Control Unit	MCU-005	
	MCU-006	
	MCU-006H	
Junction Box	FI-5002	
Analog NMEA Data Converter	IF-NMEAFI	
Wind Transducer	FI-5001	
Ethernet HUB	HUB-101	
	HUB-102	
Matching Box	MB-1100	For 1kW transducers

EQUIPMENT LISTS

Name	Type	Remarks
Rectifier	PR-62	100/110/220/230 VAC
Network (LAN) Cable	FRU-RZWPNWP-002G	Single connector waterproofed
	FRU-RZWPNWP-005G	
	FRU-RZWPNWP-010G	
	FRU-RZWPWP-002G	Dual connector waterproofed
	FRU-RZWPWP-005G	
	FRU-RZWPWP-010G	
Joint Box	TL-CAT-012	For LAN network
Connector	RZCDP08G5E-KLG7001	Waterproofed RJ45 plug
Waterproof Extension Cable	FUSA-RPZG5E-A	Adapter for waterproofed RJ45 to non-waterproofed RJ45, 0.5 m
NMEA Cable Assy.	FRU-NMEA-PMMFF-010	1 m, two connectors
	FRU-NMEA-PMMFF-020	2 m, two connectors
	FRU-NMEA-PMMFF-060	6 m, two connectors
	FRU-NMEA-PFF-010	1 m, single connector
	FRU-NMEA-PFF-020	2 m, single connector
	FRU-NMEA-PFF-060	6 m, single connector
	FRU-MM1MF1MF1001	T connector
	FRU-MM1000000001	Male, terminator
	FRU-MF000000001	Female, terminator
Cable Assembly	FRU-CCB12-MJ-01-YL	For CW + Chirp transducers
Extension Cable* ¹	C332 10M	For transducer cable extension.
	FRU-CCB12-DA-10M	
Cable Assembly	02S4147-2	Converter cable (10pin×2 -6pin), for ST sensor/water temp. sensor, 0.2m.
	AIR-033-270	Converter cable (10pin×2 -6pin), for ST sensor/water temp. sensor.
Transducer Tank	T-711-FJ12	For welded-tank mount
Speed/Temperature Sensor (ST Sensor)	ST950-FJ46-1: ST-02PSB	Thru-hull type, plastic
	ST950-FJ46-2: ST-02MSB	Thru-hull type, metal
Water Temp. Sensor	T-04MSB	Thru-hull type
	T-04MTB	Transom type
User's Guide	E42-02210	For MCU-006

*1. Use of the extension cable may cause the following problems:

- Reduced detection ability
- Wrong ACCU-FISH™ information (fish length smaller than actual length, fewer fish detections, error in individual fish detection).
- Wrong speed data
- No TD-ID recognition

1. MOUNTING

1.1 Installation of Multi Function Display

The TZT9E/TZT13E is designed to be mounted in a console or mounted on a desktop.

The installer of this equipment must read and follow the descriptions in this manual. Wrong installation or maintenance can void the warranty.

Mounting considerations

When selecting a mounting location, keep the following in mind:

- The temperature at the mounting location shall be between -15°C and $+55^{\circ}\text{C}$.
- The humidity at the mounting location shall be 94% or less at 40°C .
- Locate the unit away from exhaust pipes and ventilators.
- The mounting location should be well ventilated.
- Mount the unit where shock and vibration are minimal (compliant with IEC 60945 Ed.4).
- Keep the unit away from electromagnetic field generating equipment such as motors and generators.
- For maintenance and checking purposes, leave sufficient space around the unit and leave slack in cables. Minimum recommended space is shown in the outline drawing at back of this manual for the display units.
- Do not mount the unit on an overhead beam/bulkhead.
- A magnetic compass will be affected if the equipment is placed too close to it. Observe the compass safe distances to prevent disturbance to the magnetic compass.
- This unit has a built-in GNSS antenna. Make sure there are no obstacles above the unit which may block radio waves. If there are unavoidable obstacles and signal reception is obstructed, connect an external GNSS antenna (GP340, etc.) to this unit via NMEA 2000.
- To protect the display from UV exposure and direct sunlight when not in use, wipe off any seawater from the surface and attach the supplied sun cover after use.

Security risk considerations

To reduce the risk of theft and ensure the security, it is recommended to take the following measures:

- Secure the unit to the mounting location using a cable lock to prevent unauthorized removal of the unit.
- Install the unit in a locked location on the ship so that it cannot be easily taken out.
- Use a port blocker to block the unused LAN ports on the HUB and physically prevent unauthorized access via the network. If not blocked, the data transmission on the LAN may be intercepted.
- To prevent accidental operation, unauthorized operation while away from your seat, unauthorized use of stolen product, and leakage of information saved in this unit, the NavNet TZtouchE and smart devices that can control this unit must be locked by PIN code.
- Do not answer a scam phone call that asks for the access code of the TeamViewer. FURUNO never calls you directly.
- Due to the specifications of the NMEA 2000, the transmission data can be intercepted and tampered. Check regularly to make sure that no suspicious devices are connected to the NMEA 2000 network.
- Incidents and accidents exploiting the AIS/DSC signals are reported. Never rely solely on the received signals and messages on the screen. Always maintain a vigilant watch while underway.

1.2 Flush Mounting

Referring to the figure below, select a flat mounting location. Read the installation instructions before starting. Pay particular attention to the notes; failure to follow these instructions may cause damage to the unit.

Note 1: Do not install the unit in a completely horizontal, upward-facing orientation. To maintain waterproof performance and ensure proper drainage, the unit must be mounted with a slight inclination.

Note 2: Ensure the mounting location is flat, with no indents or protrusions, to allow a secure fit.

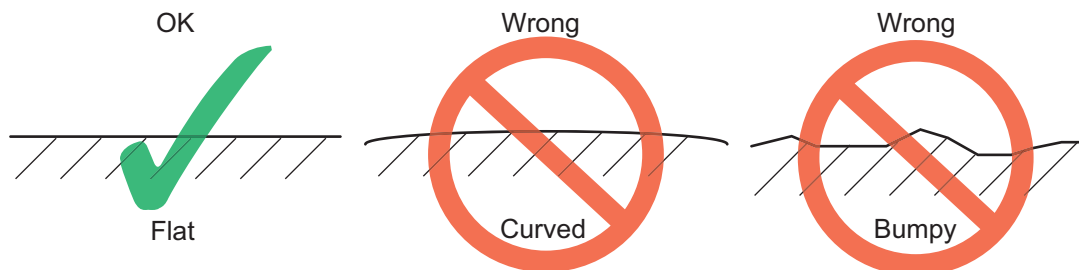

1.2.1 TZT9E

1. Prepare a cutout in the mounting location using the supplied mounting template.
2. Drill holes at each screw location (4 places) using the supplied mounting template.
3. Attach the flush mount gasket to the rear of the unit,
Note: Place the unit face-down on a soft, clean surface to prevent damage to the LCD.
4. Attach the supplied four stud bolts (M4×20) to the unit.
Note: Do not use tools, such as pliers, to attach the rods, as the unit may be damaged.

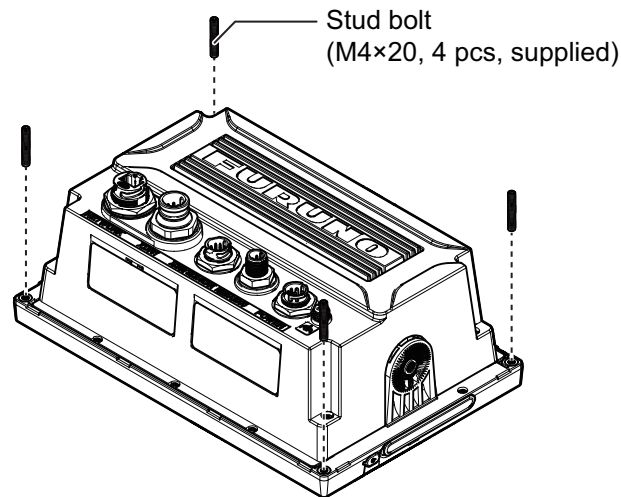

5. Connect all cables at the rear of the unit (see section 2.1 for details).
6. Set the unit to the cutout made at step 1, then secure the unit referring to the following figure.

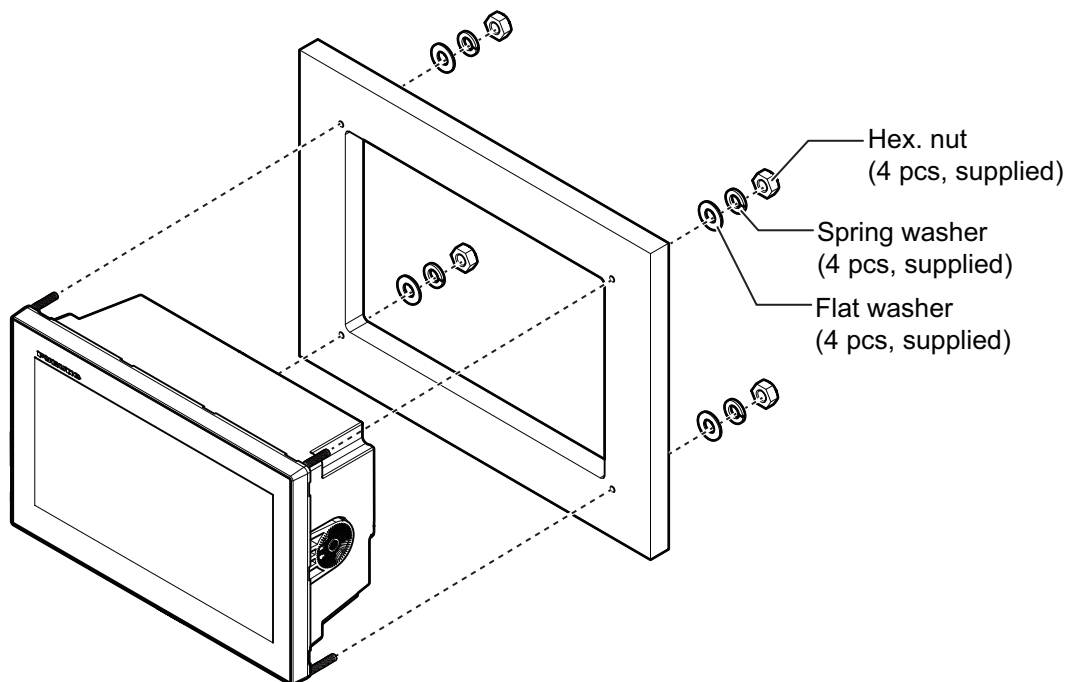

Note 1: Connection cables are not shown in the figure for simplification.

Note 2: Be sure not to pinch the cables when fitting the unit to the cutout.

1. MOUNTING

1.2.2 TZT13E

1. Prepare a cutout in the mounting location using the supplied mounting template.
2. Drill holes at each screw location (4 places) using the supplied mounting template.
3. Attach the flush mount gasket to the rear of the unit.
Note: Place the unit face-down on a soft, clean surface to prevent damage to the LCD.
4. Connect all cables at the rear of the unit (see section 2.1 for details).
5. Set the unit to the cutout made at step 1, then secure the unit referring to the following figure.

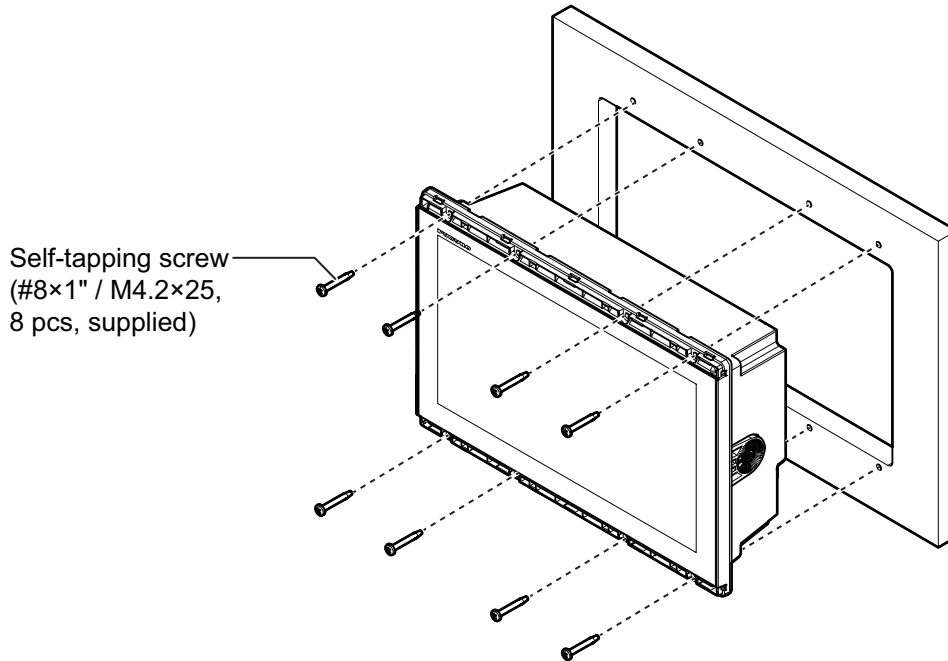

Note 1: Connection cables are not shown in the figure for simplification.

Note 2: Be sure not to pinch the cables when fitting the unit to the cutout.

6. Fit the screw covers (included as installation materials) to the top and bottom of the unit front.

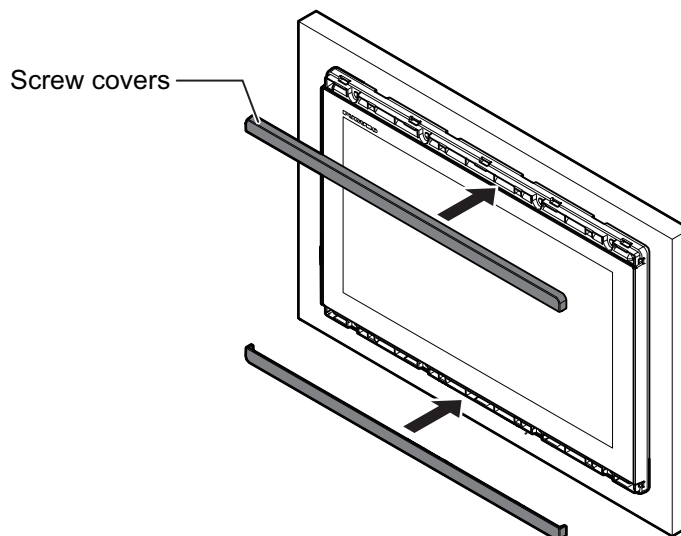

How to remove the screw covers

Use a flat-head screwdriver to remove screw covers from the unit. Start at one end of the screw cover, insert the blade of the screwdriver into each of the release points (indicated with circles in the figure below), then gently twist the screwdriver until a “pop” sound is heard.

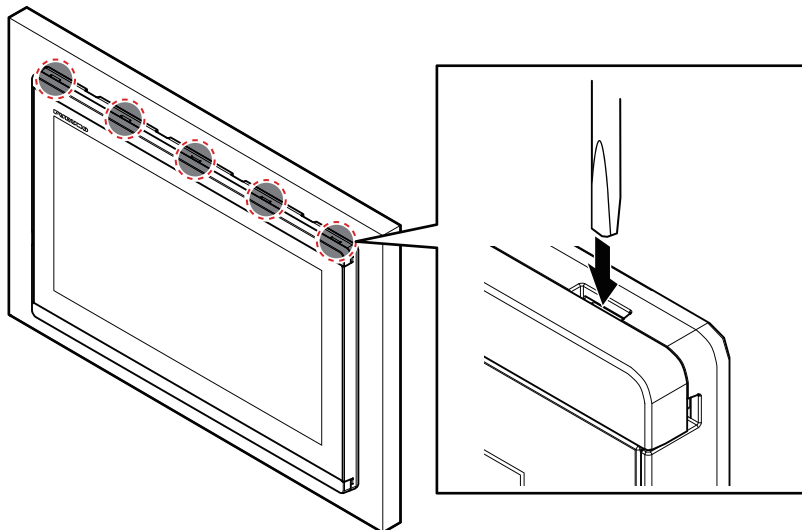

Note 1: To prevent damage to the screw cover, release the cover from one end, then work towards the opposite end. Releasing the cover in any other manner may cause damage to the cover and the unit.

Note 2: Do not use excessive force when removing the screw cover. Use of excessive force can damage the cover and the unit.

1.3 Desktop Mounting

Follow the appropriate procedure below to mount the unit.

1. Secure the bracket using the four self-tapping screws (M4.8×22, supplied).

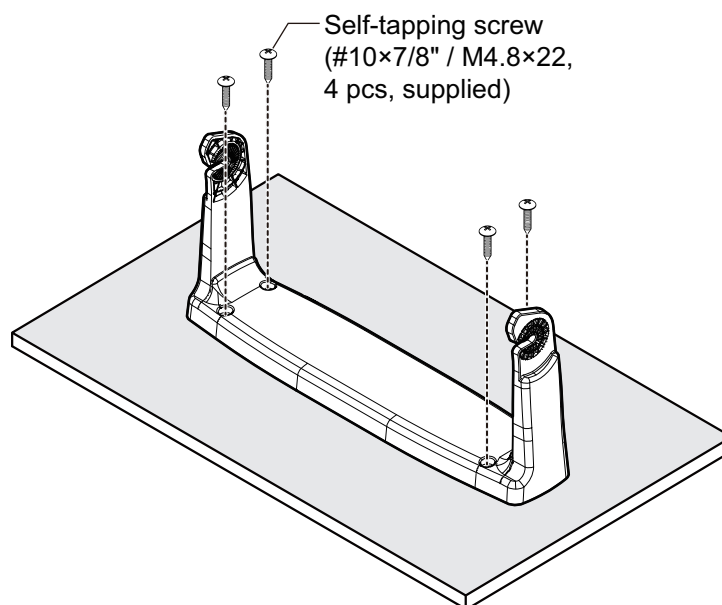

1. MOUNTING

2. Place the unit face-down on a soft, clean surface, then fit the supplied two knobs as shown in the figure below, leaving a gap of approximately 30 mm.

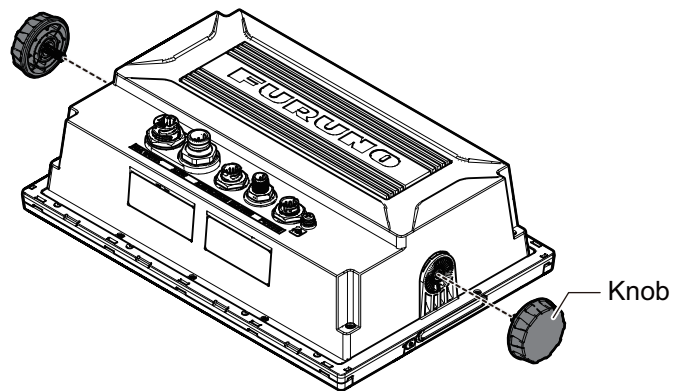

3. Connect all cables at the rear of the unit (see section 2.1 for details).
4. Set the unit to the bracket and tighten the knobs.

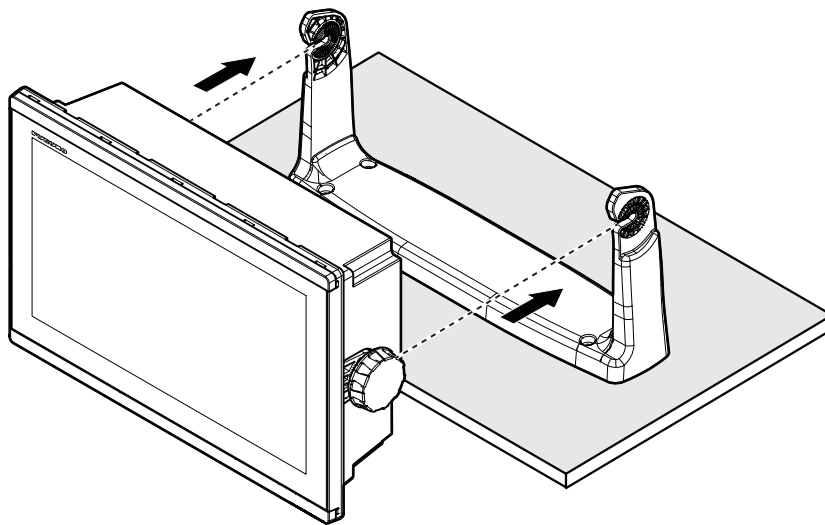

1.4 Installation of Transducers

⚠ CAUTION

⊘ Do not cover the transducer with FRP resin.
 The heat generated when the resin hardens may damage the transducer. CHIRP transducers are especially vulnerable to heat.

Note: For instructions regarding installation of network fish finder transducers, see the respective manual.

There are three methods for installing the transducer on the ship (thru-hull mount, inside the hull and transom mount) and one of those methods is to be selected according to the structure of the ship. The procedure which follows below shows how to install a small transducer (520-5PSD/5MSD) as the representative example of installation.

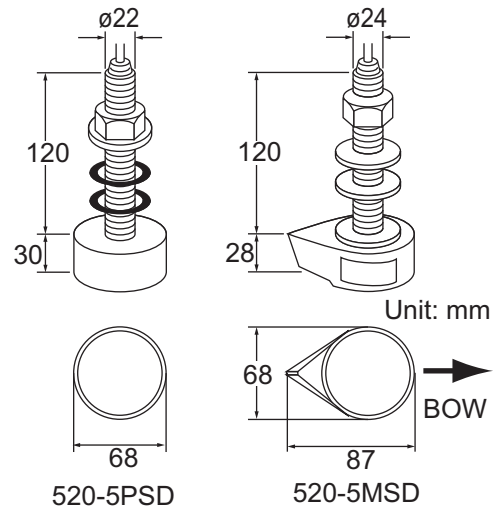

1.4.1 How to mount a transducer through the hull

Transducer mounting location

The thru-hull mount transducer provides the best performance of all, since the transducer protrudes from the hull and the effect of air bubbles and turbulence near the hull skin is reduced. If your boat has a keel, the transducer should be at least 30 cm away from it.

The performance of this fish finder is directly related to the mounting location of the transducer, especially for high-speed cruising. The installation should be planned in advance, keeping the length of the transducer cable and the following factors in mind:

- Air bubbles and turbulence caused by movement of the boat seriously degrade the sounding capability of the transducer. The transducer should, therefore, be located in a position where water flow is the smoothest. Noise from the propellers also adversely affects performance and the transducer should not be mounted nearby. The lifting strakes are notorious for creating acoustic noise, and these must be avoided by keeping the transducer in-board of them.

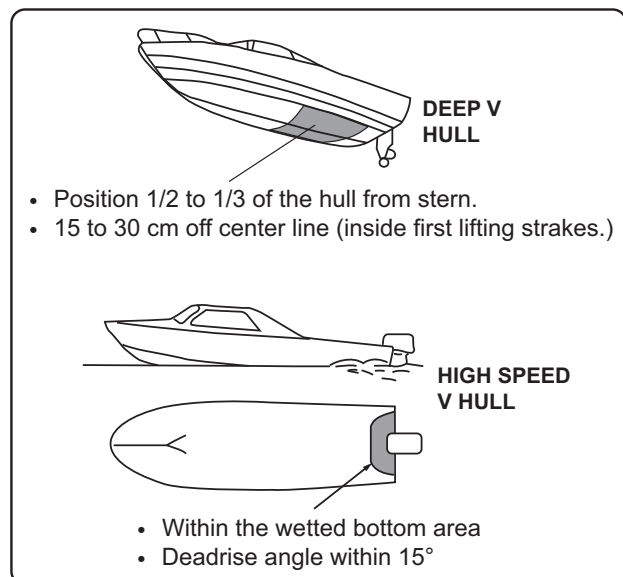

1. MOUNTING

- The transducer must always remain submerged, even when the boat is rolling, pitching or up on a plane at high speed.
- A practical choice would be somewhere between 1/3 and 1/2 of your boat's length from the stern. For planing hulls, a practical location is generally rather far astern, so that the transducer is always in water regardless of the planing attitude.

Installation procedure

1. With the boat hauled out of the water, mark the location chosen for mounting the transducer on the bottom of the hull.
2. If the hull is not level within 15° in any direction, fairing blocks made out of teak should be used between the transducer and hull, both inside and outside, to keep the transducer face parallel with the water line. Fabricate the fairing block as shown below and make the entire surface as smooth as possible to provide an undisturbed flow of water around the transducer. The fairing block should be smaller than the transducer itself to provide a channel to divert turbulent water around the sides of the transducer rather than over its face.

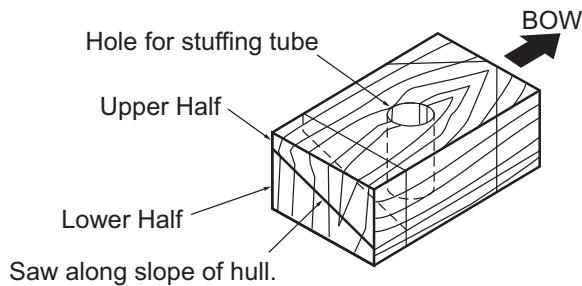

3. Drill a hole just large enough to pass the threaded stuffing tube of the transducer through the hull, making sure it is drilled vertically.
4. Apply a sufficient amount of high quality caulking compound to the top surface of the transducer, around the threads of the stuffing tube and inside the mounting hole (and fairing blocks if used) to ensure watertight mounting.
5. Mount the transducer and fairing blocks and tighten the locknut. Be sure that the transducer is properly oriented and its working face is parallel to the waterline.

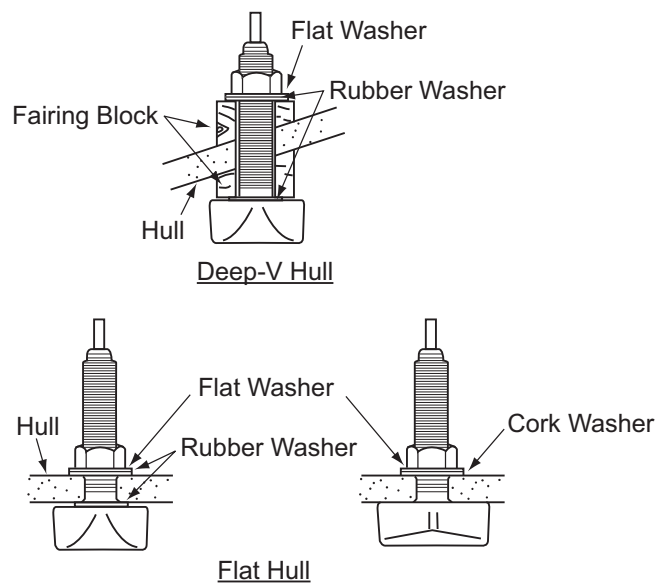

Note: Tightening torque should not exceed 39 N•m. Over-tightening will damage the plastic screws.

1.4.2 How to mount a transducer inside the hull

NOTICE

This installation method affects the ability to detect the bottom, fish and other objects because the ultrasound pulse is weakened when it passes through the hull.

Therefore, refrain from this mounting method for a transducer that supports the ACCU-FISH™ and/or bottom discrimination display feature.

Remarks on installation

This method is useful when mounting a transducer inside the hull of FRP ship, however, it affects the ability to detect the bottom, fish and other objects.

- Do the installation with the ship moored at a dock, etc. The water depth should be 6.5 to 32 feet (2 to 10 meters).
- Turn off the engine.
- Do not power the unit with the transducer in the air, to prevent damage to the transducer.
- Do not use this method on a double layer hull.
- Before attaching the transducer to the hull, check that the site is suitable, by following steps 1 to 3 in the installation procedure below.

Necessary tools

The following tools are required:

- Sandpaper (#100)
- Marine sealant
- Water-filled plastic bag

Selecting a location to install the transducer

Install the transducer on the hull plate inside of the engine room. The attenuation of the ultrasound pulse varies with the thickness of the hull. Select a location where attenuation is the lowest.

Select 2-3 locations considering the four points mentioned below.

- Mount the transducer at a location $1/2$ to $1/3$ of the length of your boat from the stern.
- The mounting location is between 15 to 50 cm from the centerline of the hull.
- Do not place the transducer over hull struts or ribs which run under the hull.
- Avoid a location where the rising angle of the hull exceeds 15° , to minimize the effect of the boat's rolling.

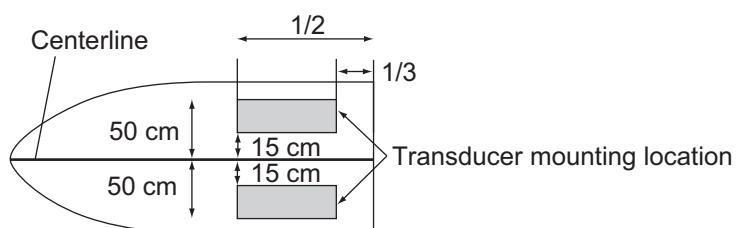

1. MOUNTING

Decide the most suitable site from the locations selected with the following procedures.

1. Connect the power cable and transducer cable to the this unit.
2. Put the transducer into a water-filled plastic bag. Press the transducer against the chosen site.
3. Turn the unit on.
4. Tap the [FURUNO] icon () to show the home screen and display mode settings. See section 3.4 for how to use the menu.
5. Tap [Settings], then tap [Fish Finder].
6. Tap [User Settings], then tap [Fish Finder Source].
7. Confirm the available fish finder from the list of available sounders, then tap the appropriate fish finder. For the purpose of this example, the default setting [TZTEFF] (internal sounder) is selected as the source.
8. Tap the [<] icon twice to return to the [Fish Finder] menu.
9. Tap [Fish Finder Initial Setup], then tap [Transducer Setup].
10. Tap [Transducer Setup Type].
11. Tap [Model].
12. Tap the [<] icon to return to [Transducer Setup] menu.
13. Tap [Model Number], scroll the menu to show your transducer model, then tap the transducer model number.
14. Tap the [<] icon twice to return to the [Fish Finder Initial Setup] menu.
15. Tap [Transmission Power], then set the transmission power to [Max].
16. Tap the [<] icon twice to return to the [Fish Finder] menu.
17. Tap [User Settings] and scroll the menu to show [Fish Finder Transmit], then tap [Fish Finder Transmit] flipswitch to on.
 - When the bottom echo is shown in reddish-brown color and depth value is displayed correctly, the installation location is suitable.
 - If the bottom echo is not shown in reddish-brown color, repeat the procedure until a suitable location is found.
18. Turn the unit power off and remove the transducer from the plastic bag and wipe the face of transducer with a cloth to remove water and any foreign material.

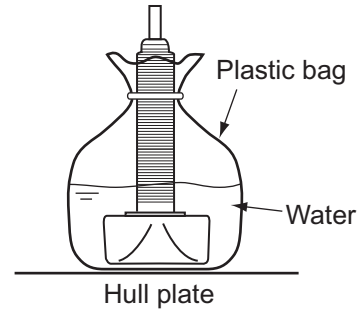

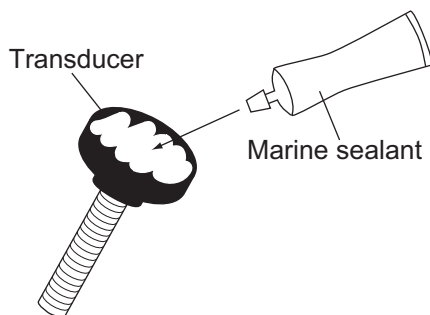

Installation procedure

1. Lightly roughen the transducer face with #100 sandpaper. Also, use the sandpaper to roughen the inside of the hull where the transducer is to be mounted. Wipe off any sandpaper dust from the face of the transducer.
2. Dry the face of the transducer and the hull. Coat the transducer face and mounting location with marine sealant. Hardening begins in approx. 15 to 20 minutes so do this step without delay.

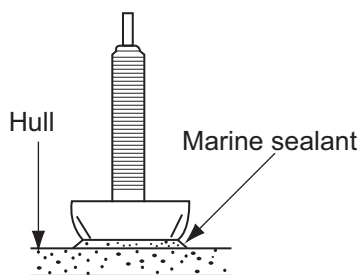

3. Attach the transducer to the hull. Press the transducer firmly down on the hull and gently twist it back and forth to remove any air which may be trapped in the marine sealant.



4. Support the transducer with a piece of wood to keep it in place while the sealant is drying. It takes 24 to 72 hours to harden completely.
5. Turn the unit on and change the menu setting as shown below. See section 3.4 for how to use the menu.
 - 1) Tap the Tap the [FURUNO] icon () to show the home screen and display mode settings.
 - 2) Tap [Settings], then tap [Fish Finder].
 - 3) Tap [Fish Finder Initial Setup].
 - 4) Tap [Transmission Power], then set the transmission power to [Max].
 - 5) Set the following menu items as shown in the table below.

Menu Item	Setting	Menu Item	Setting
Bottom Level HF	-40	Gain Offset HF	20
Bottom Level LF	-40	Gain Offset LF	20

1.4.3 How to install the transom mount transducer

The optional transom mount transducer is very commonly used, usually on relatively small I/O or outboard boats. Do not use this method on an inboard motor boat because turbulence is created by the propeller ahead of the transducer.

DO NOT over-tighten screws, to prevent damage to the transducer.

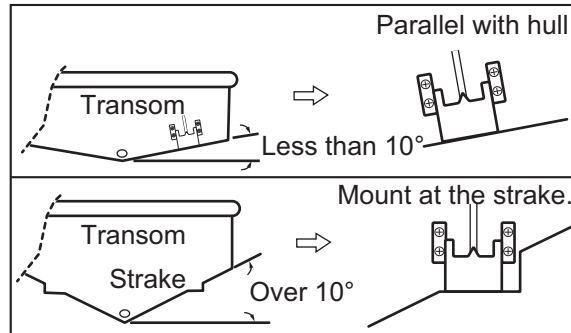

Installation procedure

A suitable mounting location is at least 50 cm away from the engine and where the water flow is smooth.

1. Drill four pilot holes for self-tapping screw ($\phi 5 \times 20$) in the mounting location.
2. Coat the threads of the self-tapping screws ($\phi 5 \times 20$) for the transducer with marine sealant for waterproofing. Attach the transducer to the mounting location with the self-tapping screws.
3. Adjust the transducer position so the transducer faces right to the bottom. If necessary, to improve water flow and minimize air bubbles staying on the transducer face, incline the transducer about 5° at the rear. This may require a certain amount of experimentation for fine tuning at high cruising speeds.
4. Tape the location shown in the right figure.
5. Fill the gap between the wedge front of the transducer and transom with epoxy material to eliminate any air spaces.
6. After the epoxy hardens, remove the tape.

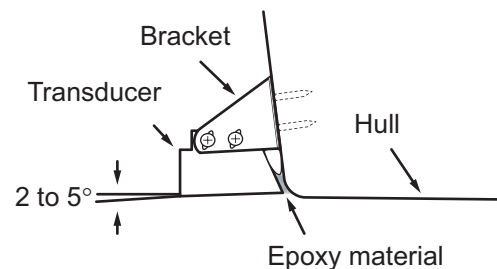
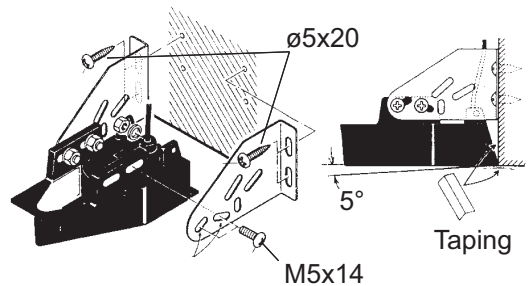

Transducer protrusion

If the hull is not level within 15° in any direction, install the transducer so that it protrudes from the hull, to keep the transducer face parallel with the water line, not with the hull.

This installation method has a merit for avoiding the bubbles by diverting turbulent water around the sides of the transducer rather than over its face. However, it may cause damage to the transducer during trailering, launching, hauling, and storage.

Transducer preparation

Before putting your boat in water, wipe the face of the transducer thoroughly with a liquid detergent. This will lessen the time necessary for the transducer to have good contact with the water. Otherwise the time required for complete "saturation" will be lengthened and performance will be reduced.

DO NOT paint the transducer. Performance will be affected.

1.4.4 How to install a triducer

DO NOT over-tighten screws, to prevent damage to the transducer.

Tools and materials required

- Scissors
- Safety goggles
- Electric drill
- Drill bit:
For bracket holes: 4 mm, #23, or 9/64"
For fiberglass hull: chamfer bit (preferred), 6 mm, or 1/4"
For transom hole: 9 mm or 3/4" (optional)
For cable clamp holes: 3 mm or 1/8"
- Straight edge
- Pencil
- Water-based anti-fouling paint (mandatory in salt water)
- Masking tape
- Dust mask
- Screwdrivers
- Marine sealant
- Cable ties

525STID-MSD

The optional triducer 525STID-MSD is designed for thru-hull mounting. Note the following points when installing.

- Select a location where turbulence or bubbles do not occur when cruising.
- Select a location where noises from propellers and stripe lines are lessened.
- The transducer must always remain submerged, even when the boat is rolling, pitching or up on a plane at high speed.

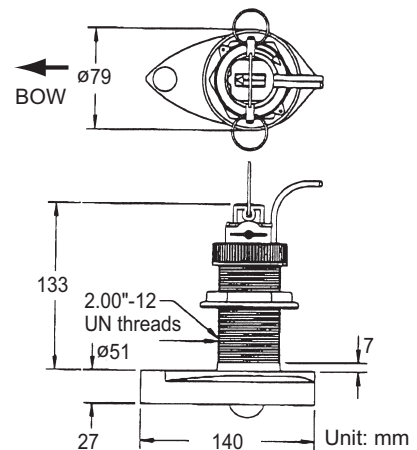
**525STID-PWD**

The optional triducer 525STID-PWD is designed for transom mounting.

However, select the location where influences from bubbles and turbulences to ensure the best performance. Allow adequate space above the bracket for it to release and rotate the sensor upward as shown in the right illustration.

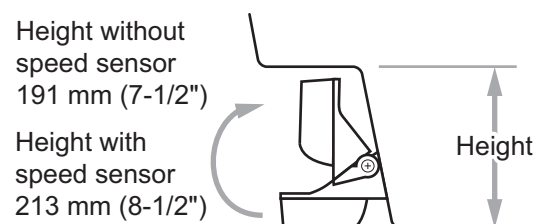

1. MOUNTING

Mount the sensor close to the centerline of your boat. On slower heavier displacement hulls, positioning it farther from the centerline is acceptable.

For single drive boat, mount on the star-board side at least 75 mm (3") beyond the swing radius of the propeller, as shown in the right figure.

For twin drive boat, mount between the drives.

Note 1: Do not mount the sensor in an area of turbulence or bubbles, near water in-take or discharge openings; behind strakes, struts, fittings, or hull irregularities; behind eroding paint (an indication of turbulence).

Note 2: Avoid mounting the sensor where the boat may be supported during trailering, launching, hauling, and storage.

Pretest for speed and temperature

Connect the sensor to the instrument and spin the paddlewheel. Check for a speed reading and the approximate air temperature. If there is no reading, return the sensor to your place of purchase.

How to install the bracket

1. Cut out the installation template (enclosed with transducer) along the dotted line.
2. At the selected location, position the template, so the arrow at the bottom is aligned with the bottom edge of the transom. Being sure the template is parallel to the waterline, tape it in place.

Warning: Always wear safety goggles and a dust mask.

3. Using a 4 mm, #23, or 9/64" bit, drill three holes 22 mm (7/8") deep at the locations indicated. To prevent drilling too deeply, wrap masking tape around the bit 22 mm (7/8") from the point.

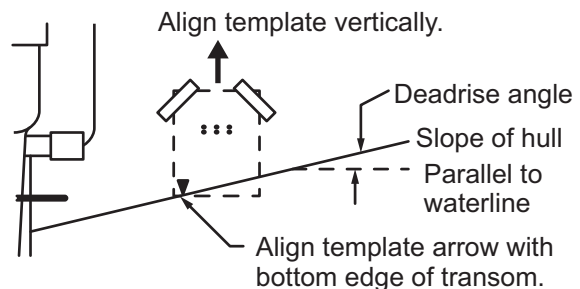

Fiberglass hull: Minimize surface cracking by chamfering the gelcoat. If a chamfer bit or countersink bit is not available, start drilling with a 6mm or 1/4" bit to a depth of 1 mm (1/16").

4. If you know your transom angle, the bracket is designed for a standard 13° transom angle.
11°-18°angle: No shim is required. Skip to step 3 in "Adjustments".
Other angles: The shim is required. Skip to step 2 of "Adjustments".
If you do not know the transom angle, temporarily attach the bracket and sensor to the transom to determine if the plastic shim is needed.
5. Using the three #10 x 1-1/4" self-tapping screws, temporarily screw the bracket to the hull. DO NOT tighten the screws completely at this time. Follow steps 1-4 in "How to attach the sensor to the bracket", before proceeding with "Adjustments".

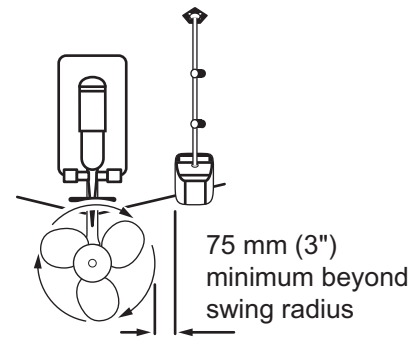

Adjustments

- Using a straight edge, sight the underside of the sensor relative to the underside of the hull. The stern of the sensor should be 1-3 mm (1/16-1/8") below the bow of the sensor or parallel to the bottom of the hull.

Note: Do not position the bow of the sensor lower than the stern because aeration will occur.

- To adjust the sensor's angle relative to the hull, use the tapered plastic shim provided. If the bracket has been temporarily fastened to the transom, remove it. Key the shim in place on the back of the bracket.

2°-10° transom angle (stepped transom and jet boats): Position the shim with the tapered end down.

19°-22° transom angle (small aluminum and fiberglass boats): Position the shim with the tapered end up.

- If the bracket has been temporarily fastened to the transom, remove it. Apply a marine sealant to the threads of the three #10 × 1-1/4" self-tapping screws to prevent water seeping into the transom. Screw the bracket to the hull. Do not tighten the screws completely at this time.

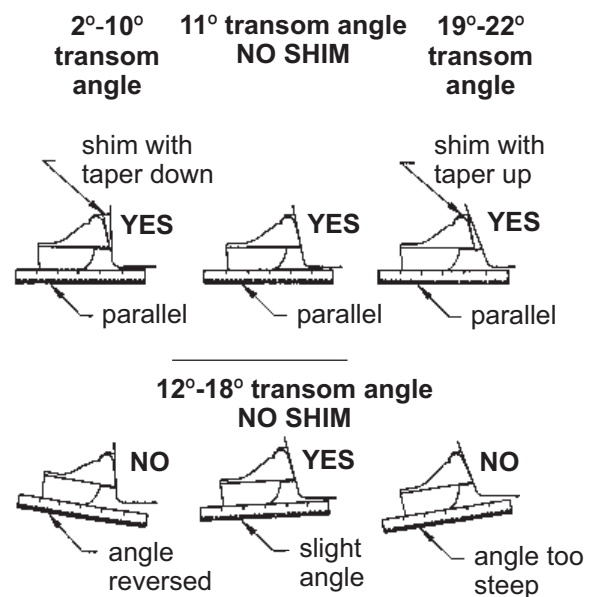

- Repeat step 1 to ensure that the angle of the sensor is correct.

⚠ CAUTION

Ensure that the angle of the sensor is correct.

Do not position the sensor farther into the water than necessary to avoid increasing drag, spray, and water noise and reducing boat speed.

- Using the vertical adjustment space on the bracket slots, slide the sensor up or down to provide a projection of 3 mm (1/8"). Tighten the screws.

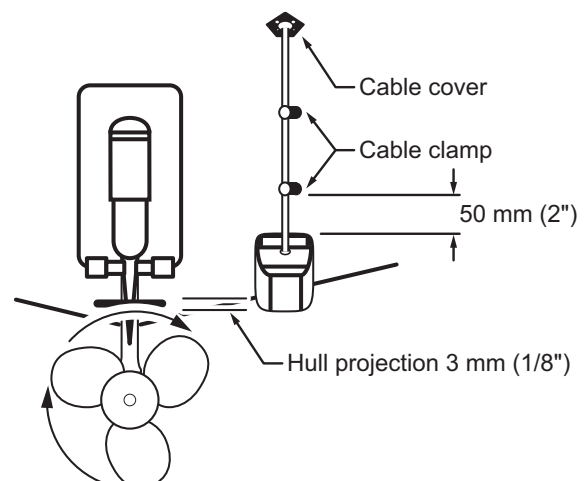

1. MOUNTING

How to attach the sensor to the bracket

1. If the retaining cover near the top of the bracket is closed, open it by depressing the latch and rotating the cover downward.
2. Insert the sensor's pivot arms into the slots near the top of the bracket.
3. Maintain pressure until the pivot arms click into place.
4. Rotate the sensor downward until the bottom snaps into the bracket.
5. Close the retaining cover to prevent the accidental release of the sensor when your boat is underway.

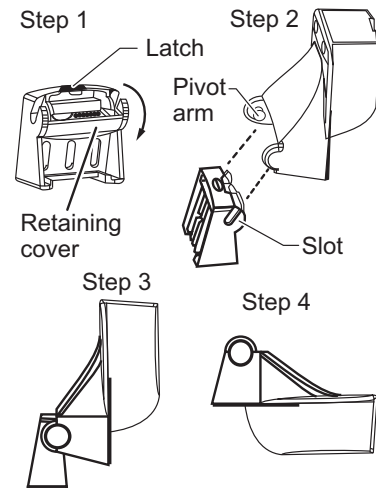

How to route the cable

Route the sensor cable over the transom, through a drain hole, or through a new hole drilled in the transom above the waterline. If a hole must be drilled, choose a location well above the waterline. Check for obstructions such as trim tabs, pumps, or wiring inside the hull. Mark the location with a pencil. Drill a hole through the transom using a 19 mm or 3/4" bit (to accommodate the connector). Always wear safety goggles and a dust mask.



1. Route the cable over or through the transom. On the outside of the hull secure the cable against the transom using the cable clamps. Position a cable clamp 50 mm (2") above the bracket and mark the mounting hole with a pencil.
2. Position the second cable clamp halfway between the first clamp and the cable hole. Mark this mounting hole.
3. If a hole has been drilled in the transom, open the appropriate slot in the transom cable cover. Position the cover over the cable where it enters the hull. Mark the two mounting holes.
4. At each of the marked locations, use a 3 mm or 1/8" bit to drill a hole 10 mm (3/8") deep. The prevent drilling too deeply, wrap masking tape around the bit 10 mm (3/8") from the point.
5. Apply marine sealant to the threads of the #6 × 1/2" self-tapping screw to prevent water from seeping into the transom. If you have drilled a hole through the transom, apply marine sealant to the space around the cable where it passes through the transom.
6. Position the two cable clamps and fasten them in place. If used, push the cable cover over the cable and screw it in place.
7. Route the cable to the display unit being careful not to tear the cable jacket when passing it through the bulkhead(s) and other parts of the boat. To reduce electrical interference, separate the sensor cable from other electrical wiring and "noise" sources. Coil any excess cable and secure it in place with zip-ties to prevent damage.

1.5 Sensors (Option)

1.5.1 Speed/temperature (ST) sensors (ST950-FJ46-1, ST950-FJ46-2) installation

Mounting considerations

Select a suitable mounting location, considering the following:

- Select a mid-boat flat position. The sensor does not have to be installed perfectly perpendicular.
- Select a location in the forward direction viewing from the drain hole, to allow for circulation of cooling water.
- Locate the sensor away from heat sources.
- Select a location where the shock and vibration are minimal.
- Select a location away from water flow from keel, water discharge pipe, etc.
- Do not install fore of the transducer, to prevent disturbance (and loss of performance).

Mounting procedure

1. Dry-dock the boat.
2. Make a hole of approx. 51 mm diameter.
3. Unfasten locknut and remove the flange of the sensor.
4. Apply high-grade sealant to the flange of the sensor.
5. Pass the sensor casing through the hole.
6. Face the notch on the sensor toward boat's bow and tighten the flange.
7. Set the sensor section to the sensor casing and tighten the locknut.
8. Launch the boat and check for water leakage around the sensor.

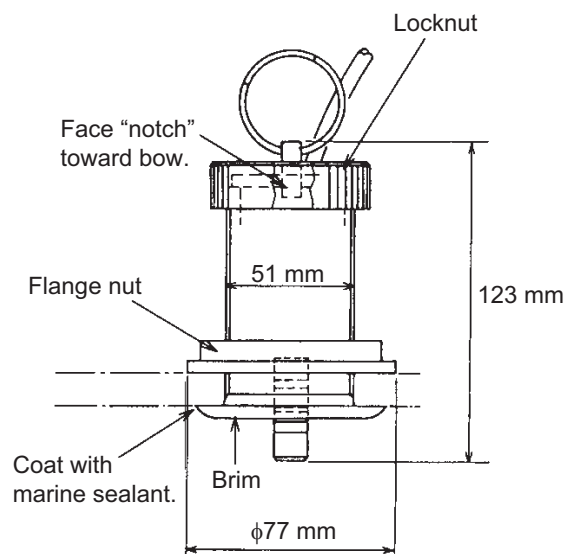

1.5.2 Temperature sensors (T-04MSB, T-04MTB) installation

See "INSTALLATION OF TEMPERATURE SENSORS" on page AP-12 for how to install the temperature sensors.

1. MOUNTING

This page is intentionally left blank.

2. WIRING

2.1 Interface Connections

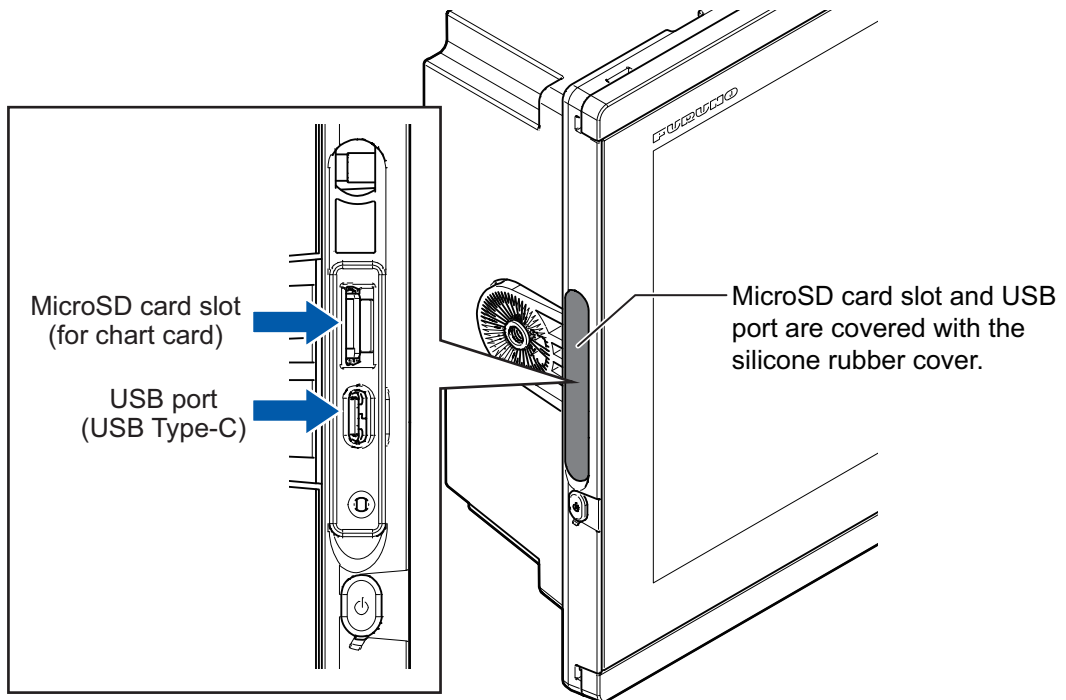
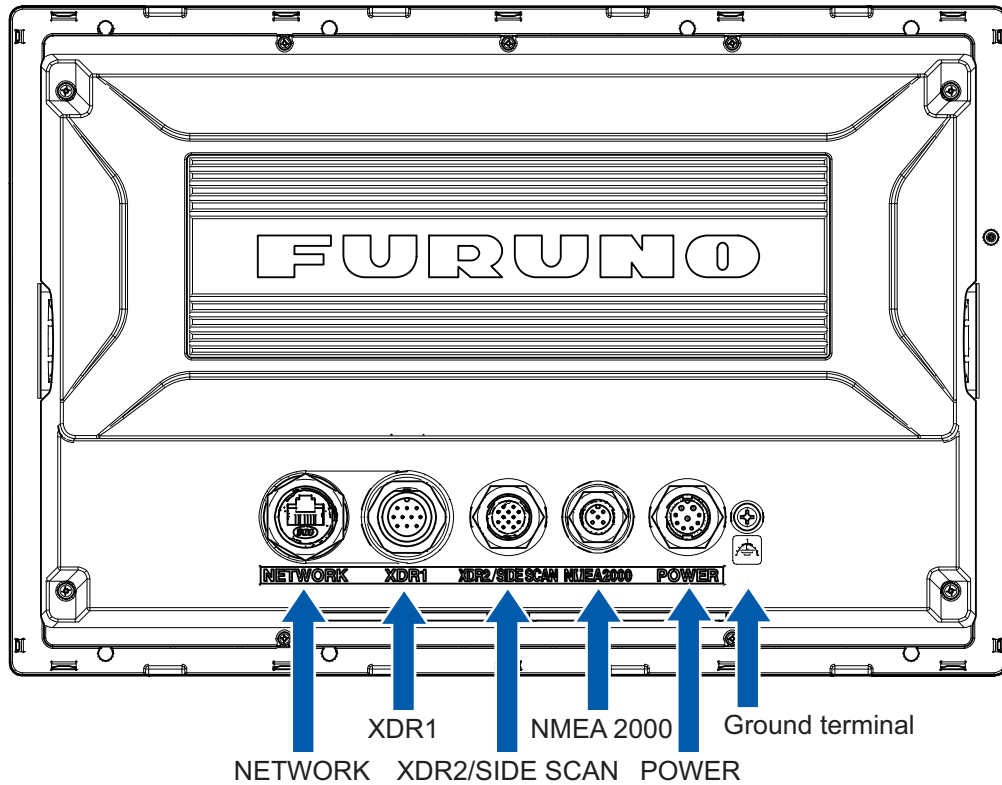

Note 1: The MicroSD card slot and USB port are positioned at a slight angle.

Note 2: To ensure the waterproofing performance, make sure to close the cover for the MicroSD card slot and USB port.

NETWORK port

You can connect an external network device using a LAN cable. Use HUB-101 or HUB-102 (option) when connecting multiple devices. The MCU-005 can also be connected via a PoE hub.

Note: If you cut off the waterproofed plug on the LAN cable to pass the cable through a pipe, etc., attach the optional waterproofed RJ plug (FUSA-RPZG5E-A) after routing the cable.

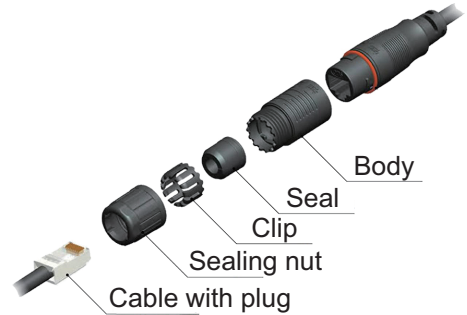

XDR1 port, XDR2/SIDE SCAN port

The type of transducer determines the port to which the transducer cable is connected (Refer to "TRANSDUCER LIST" on page AP-17 for details).

Note 1: Supply voltages are different depending on XDR ports. Be sure to connect each transducer to the correct port.

Note 2: When using the optional extension cable (for 10-pin: C332 10M, for 12-pin: FRU-CCB12-DA-10M), keep the following points in mind.

- Detection performance may be degraded.
- False positives (under-display of fish length, reduced number of detections, false detection of single fish) may occur when using the ACCU-FISH™ function.
- Values measured by the ship speed sensor may differ from the actual values.
- TD-ID may not work.

Note 3: To install the optional ST sensor or water temperature sensor, use the optional cable assembly (type: 02S4147-2 or AIR-033-270) and connect the sensor to the [XDR1] port with the transducer. Cannot be used simultaneously with the dual frequency transducer which has a 12-pin connector.

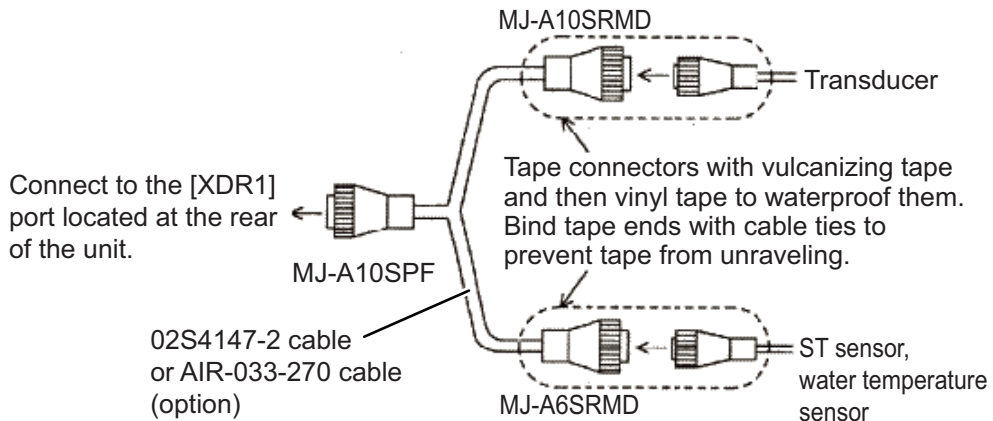

Note 4: When you use the CW and CHIRP transducers simultaneously, connect the CW transducer to the XDR1 port and connect the CHIRP transducer to the XDR2/SIDE SCAN port. Requires the optional FRU-CCB12-MJ-01-YL cable to connect the CHIRP transducer to the XDR2/SIDE SCAN port,

NMEA2000 port

The TZT9E/13E can be connected to the NMEA 2000 sensors and multiple compatible NavNet TZT units using a micro type NMEA 2000 connector. Connect them all to the same network backbone cable (Refer to section 2.7 for details).

POWER port

Connect the power supply and NMEA 0183 equipment (TX only). See section 2.2 and section 2.4.

Ground terminal

See section 2.3.

USB port (USB Type-C)

The TZT9E/13E has one USB Type-C port which can be used to connect the USB device (ex. USB flash memory).

2.2 Power Cable

Connect the power cable (CBC0FS0900, 1.5 m, supplied) to the POWER port. When connecting the power supply, connect the positive and negative terminals correctly. To protect electrical circuits, install a fuse box and 5A fuse (supplied locally) to the power line.

Note 1: Turn off the power at the switchboard before beginning the connection.

Note 2: Do not connect the ground/shield wire of the power cable to the ship's ground.

2.3 Grounding Wire

For the built-in Fish Finder and CHIRP Side Scan, connect a ground wire (IV-8sq., local supply) to the ship's ground terminal on the rear panel with a crimp-on lug (φ5, local supply). Connect the other end to ship's ground.

2.4 NMEA 0183 Connection (TX Only)

Connect the NMEA 0183 equipment to the POWER port using the supplied power cable. Use the table below for reference when connecting the NMEA 0183 equipment.

Pin No.	Signal	Wire Color
1	PWR_IN+	Red
2	PWR_IN-	Black
3	SHIELD	—
4	N/C	—
5	N/C	—
6	NMEA_TD-B	Blue
7	NMEA_TD-A	White
8	N/C	—
9	N/C	—

How to set up NMEA 0183 data output

Note: To input NMEA 0183 data, see section 2.7.2

1. Tap the [FURUNO] icon () to show the home screen.
2. Tap [Settings] → [Initial Setup] → [Data Sensors].
3. Tap [NMEA0183 Output].

Note: When the PIN code lock is activated, enter the PIN code to change the [NMEA0183 Output] settings.
4. Tap [Baud Rate] to set the output baud rate. Available options are [4,800], [9,600] and [38,400].
5. Tap the appropriate setting then tap the [<] icon.
6. Tap [NMEA-0183 Version] to set the version. Available options are [1.5], [2.0] and [3.0].
7. Tap the appropriate setting then tap the [<] icon.
8. Select the sentences to output. Tap a sentence, then tap its flipswitch on to output the sentence.
9. Tap the [Close] icon at the top right of the screen to close the menus.

2.5 DRS Radar Sensor Connections

The figures below show connection examples with radar sensors which are compatible with the TZT9E/13E.

For details regarding connection and cables required for connection with the radar sensor, see the radar sensor's Installation Manual.

Connection examples for radome sensors

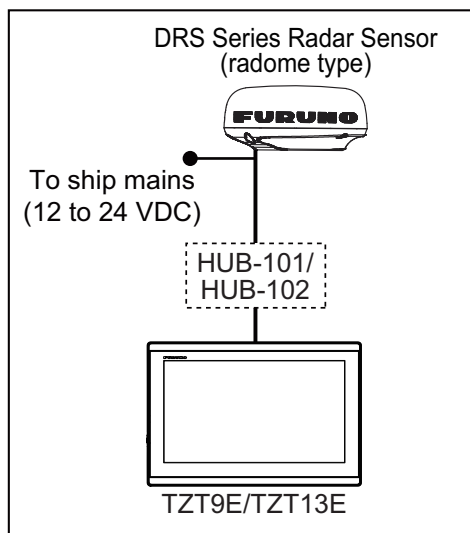

Connection examples for open-array sensors

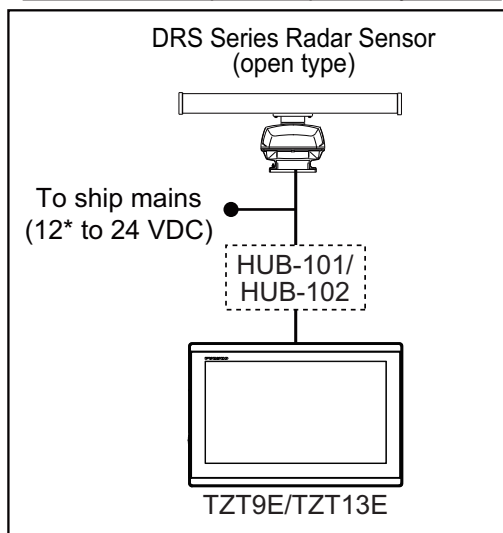

*: 12 VDC is only used with DRS6A-NXT. All other open array DRS sensors require 24 VDC.

2.6 Network Connection with Other TZT Series Units

Your TZT9E/13E is equipped with a network connector (RJ45). Like previous NavNet series equipment, the TZT9E/13E is able to share Radar images and other information, across an Ethernet connection. Up to six NavNet TZtouch units may be connected to the same network at one time (see page iv for the details). However, for configurations with one or more TZT2BB included, the maximum number of networked NavNet TZtouch units is four. For example, a configuration with one TZT9E/13E and one TZT12F can have two TZT2BB units connected.

2.7 NMEA 2000 Connection

The TZT9E/13E has one NMEA 2000 connector (micro type connector). All NavNet TZtouch series must be connected to the same NMEA 2000 backbone.

What is NMEA 2000?

NMEA 2000 (also known as CAN bus) is a communication protocol that shares multiple data and signals through a single backbone cable. You can simply connect any NMEA 2000 devices onto the backbone cable to expand your network on-board. With NMEA 2000, IDs are assigned to all the devices in the network, and the status of each sensor in the network can be detected. All the NMEA 2000 devices can be incorporated into the NMEA 2000 network. For detailed information about NMEA 2000 wiring, see "FURUNO CAN bus Network Design Guide" (Type: TIE-00170).

2. WIRING

2.7.1 How to connect the NavNet TZtouchE to NMEA 2000 equipment

Below is an example for NMEA 2000 equipment connections.

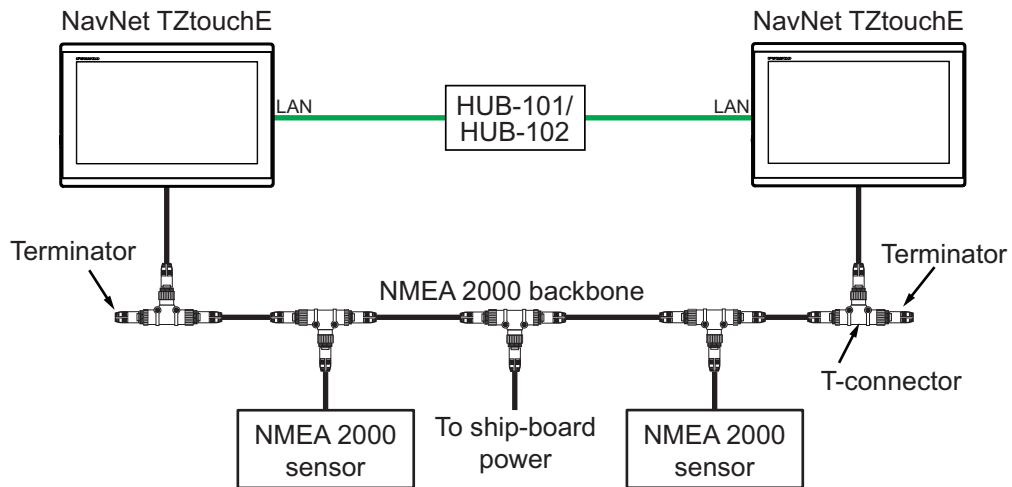

Note 1: The NMEA 2000 network requires a dedicated NMEA 2000 power supply. Turn the NMEA 2000 network power on before turning your connected equipment on.

Note 2: Terminators must be installed at both ends of the NMEA 2000 backbone cable. See the "EQUIPMENT LISTS" on page v for available terminators.

2.7.2 NMEA 0183 equipment data input

To connect NMEA 0183 equipment to TZT9E/13E, use the NMEA 2000 network via the optional NMEA data converter IF-NMEA2K2. This NMEA connection can accept a baud rate of 4800 or 38400.

Heading input to TZT9E/13E allows functions such as radar overlay and course stabilization (North up, etc.) in the radar operating modes. The NMEA 0183 heading refresh rate needs to be 100 ms in order for any radar function to work properly. NMEA 0183 heading can be accepted on any NMEA 2000 port at a baud rate up to 38400 bps.

Note 1: To output NMEA 0183 data from this unit, see section 2.4.

Note 2: When using the ARPA function, set the heading refresh rate to 100 ms.

Note 3: For more information on connecting and wiring NMEA data converter, refer to their respective installation manuals.

2.7.3 NMEA 2000 input/output

Input PGN

PGN	Description
059392	ISO Acknowledgment
059904	ISO Request
060160	ISO Transport Protocol, Data Transfer
060416	ISO Transport Protocol, Connection Management - BAM group function
060928	ISO Address Claim
061184	Self Test Group Function (Proprietary PGN)
065240	ISO Commanded Address

PGN	Description
065280	Heave (Proprietary PGN)
126208	NMEA-Request Group Function
	NMEA-Command Group Function
	NMEA-Acknowledge Group Function
126464	PGN List - Transmit PGN's group function
126720	Memory Clear Group Function (Proprietary PGN)
126983	Alert
126985	Alert Text
126992	System Time
126996	Product Information
126998	Configuration Information
127237	Heading/Track Control
127245	Rudder
127250	Vessel Heading
127251	Rate of Turn
127252	Heave
127257	Attitude
127258	Magnetic Variation
127488	Engine Parameters, Rapid Update
127489	Engine Parameters, Dynamic
127493	Transmission Parameters, Dynamic
127498	Engine Parameters, Static
127503	AC Input Status
127505	Fluid Level
127506	DC Detailed Status
127508	Battery Status
128259	Speed
128267	Water Depth
129025	Position, Rapid Update
129026	COG & SOG, Rapid Update
129029	GNSS Position Data
129033	Local Time Offset
129038	AIS Class A Position Report
129039	AIS Class B Position Report
129040	AIS Class B Extended Position Report
129041	AIS Aids to Navigation (AtoN) Report
129291	Set & Drift, Rapid Update
129538	GNSS Control Status
129540	GNSS Satellites in View
129793	AIS UTC and Date Report
129794	AIS Class A Static and Voyage Related Data
129795	AIS Addressed Binary Message
129797	AIS Binary Broadcast Message
129798	AIS SAR Aircraft Position Report
129801	AIS Addressed Safety Related Message
129802	AIS Safety Related Broadcast Message
129808	DSC Call Information
129809	AIS Class B "CS" Static Data Report, Part A
129810	AIS Class B "CS" Static Data Report, Part B

2. WIRING

PGN	Description
130306	Wind Data
130310	Environmental Parameters
130311	Environmental Parameters
130312	Temperature
130313	Humidity
130314	Actual Pressure
130316	Temperature, Extended Range
130576	Trim Tab Status
130577	Direction Data
130578	Vessel Speed Component
130817	Furuno GNSS Control Status (Proprietary PGN)
130818	Heading & Attitude Sensor Control Status (Proprietary PGN)
130820	Motion Sensor Status(Proprietary PGN)
130822	Unit Division Code(Proprietary PGN)
130823	Browser Control Status(Proprietary PGN)
130826	Multi Sats In View (Proprietary PGN)
130827	NAVpilot General Message (Proprietary PGN)
130828	Mark Position Information(Proprietary PGN)
130845	Multi Sats in View Extended (Proprietary PGN)
130846	Motion Sensor Status Extended (Proprietary PGN)
130880	Additional Weather Data(Proprietary PGN)

Output PGN

The NMEA 2000 output PGN setting (found under the [Initial Setup] menu) is global to the network. Note that only one NavNet TZtouch series unit will output NMEA 2000 data on the network at a time: the NavNet TZtouch series unit which is powered ON first. If that display is turned OFF, another will take its place to output the data.

PGN	Description	Output cycle (msec)
059392	ISO Acknowledgement	
059904	ISO Request	
060928	ISO Address Claim	
061184	Self Test Group Function (Proprietary PGN)	
065287	HID Target Status (Proprietary PGN)	
126208	NMEA-Request group function	
	NMEA-Command group function	
	NMEA-Acknowledge group function	
126464	PGN List-Transmit PGN's group function	
	PGN List-Received PGN's group Function	
126720	Memory Clear Group Function (Proprietary PGN)	
126984	Alert Response	
126992	System Time	1000
126993	Heartbeat	60000
126996	Product Information	
126998	Configuration Information	
127250	Vessel Heading	100
127251	Rate of Turn	100
127257	Attitude	1000

PGN	Description	Output cycle (msec)
127258	Magnetic Variation	1000
128259	Speed	1000
128267	Water Depth	1000
128275	Distance Log	1000
129025	Position, Rapid Update	100
129026	COG & SOG, Rapid Update	250
129029	GNSS Position Data	1000
129033	Local Time Offset	1000
129283	Cross Track Error	1000
129284	Navigation Data	1000
129285	Navigation-Route/WP information	
130306	Wind data	100
130310	Environmental Parameters	500
130312	Temperature	2000
130313	Humidity	2000
130314	Actual Pressure	2000
130316	Temp., Extended Range	2000
130821	NAV Source Select (Proprietary PGN)	
130822	Unit Division Code (Proprietary PGN)	
130823	Browser Control Status (Proprietary PGN)	
130827	NAVpilot General Message (Proprietary PGN)	
130841	N2K System Setup Information (Proprietary PGN)	

2.8 Example of TZT9E/13E System Configuration

Mid-size vessels (External GPS, Radar)

This is a sample of the chart plotter/radar installation. Refer to "SYSTEM CONFIGURATION" on page iii for more details.

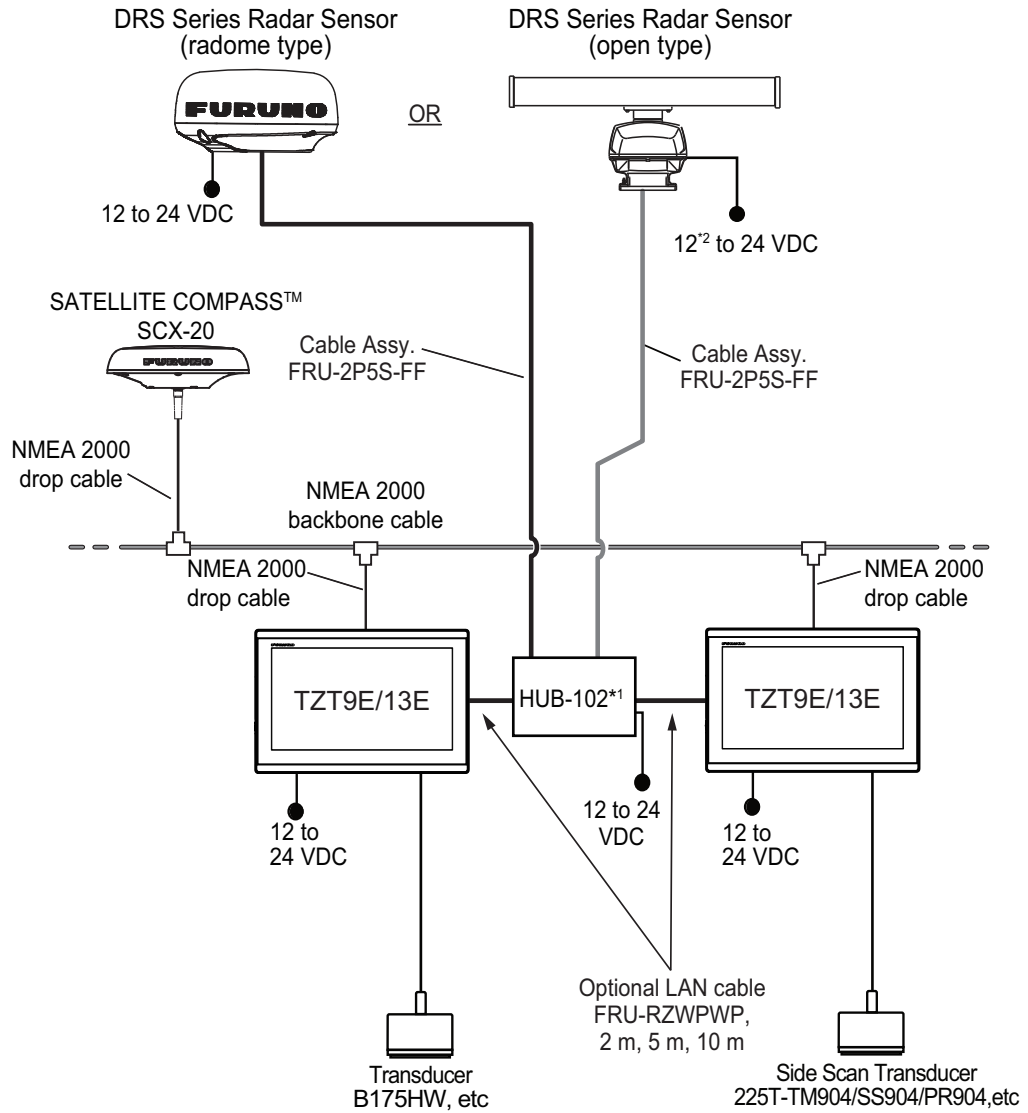

*1: Required when two or more network units are connected to the TZT9E/13E.

*2: 12 VDC is only used with DRS6A-NXT. All other open array DRS sensors require 24 VDC.

2.9 SUZUKI Outboard Motor Connection

The NavNet TZtouchE can display the SUZUKI engine information by connecting a SUZUKI outboard motor compatible with the CAN2 network system. For details regarding the SUZUKI engine display, see your Operator's Manual or eGuide.

To connect the SUZUKI outboard engine, following equipment is required. For how to purchase and connect the equipment, contact a SUZUKI Motor Corporation dealer.

- SUZUKI gateway (34923-96L1*)
- Dual gauge adapter (36667-96L4*)
- SUZUKI multi-function gauge (SMG4)

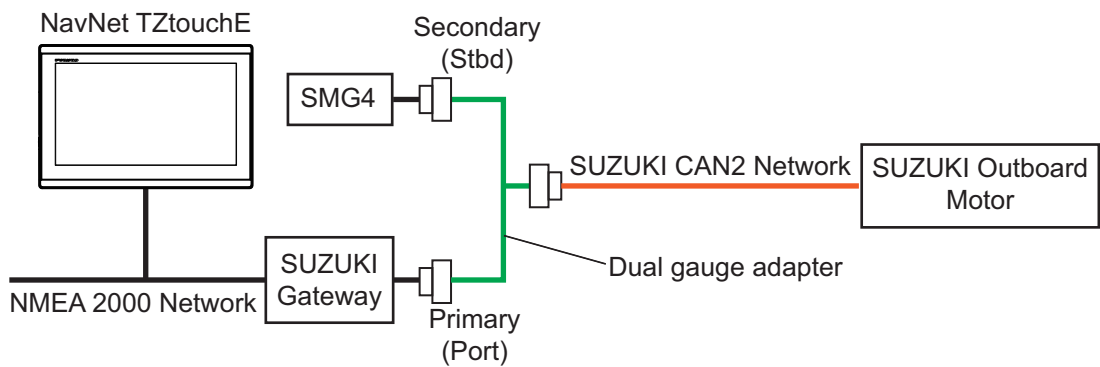

Note: The NavNet TZtouchE is compatible with DBW-type outboard motors manufactured in 2022 or later, and mechanical-type outboard motors manufactured in 2023 or later. For details of compatible modes, contact a SUZUKI Motor Corporation dealer.

2. WIRING





This page is intentionally left blank.

3. HOW TO SET UP THE EQUIPMENT

This chapter shows you how to set up your system according to the equipment you have connected.

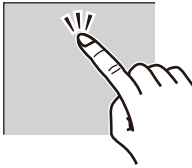
Touch control description

The touch control depends on the screen type. The basic operations to use during the installation setup are in the following table.

	Operating by a finger	Function
Tap		<ul style="list-style-type: none"> • Select a menu item. • Select a setting option where there are multiple options. • Select an object. • Display the pop-up menu when available.
Drag		<ul style="list-style-type: none"> • Scroll the menu.
Pinch	  Zoom in Zoom out	Change the fish finder, chart plotter and radar range.

3. HOW TO SET UP THE EQUIPMENT

Control description

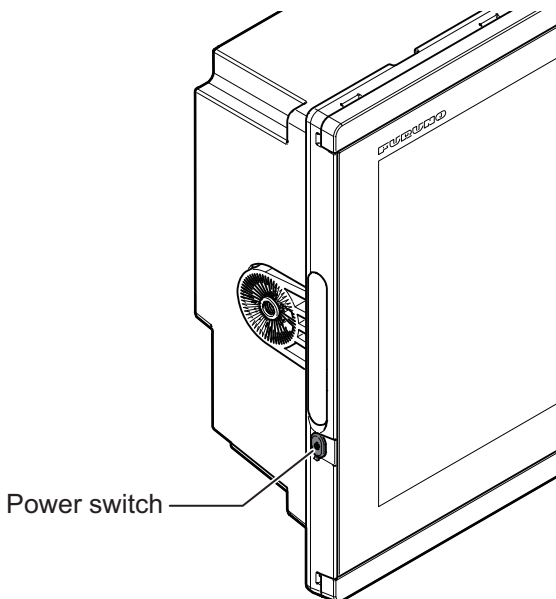

Item	Function
 Power switch	<ul style="list-style-type: none"> • Push: Turns the power on. Pushing the switch with the unit powered displays the [Quick Access] window. • <u>[Quick Access] window</u> • Toggles radar, fish finder, multibeam sonar and Navpilot between transmit and stand-by. • Adjusts the display brilliance and hue, and selects the day or night mode. • Turns the power off (device or network). • Locks, unlocks the touch screen.

How to operate the menus

The following procedure shows how to use the menu system.

1. Press the power switch (🔌) to turn the power on.
2. After the startup process completes, the last-used display appears and a warning message is displayed. After reading the message, tap [OK].
3. Tap the [FURUNO] icon (🏠 **FURUNO**) to show the home screen and available display modes.



4. Tap [Settings] to open the [Settings] menu.

- Tap [Initial Setup] and scroll the main menu, then tap an appropriate menu item.

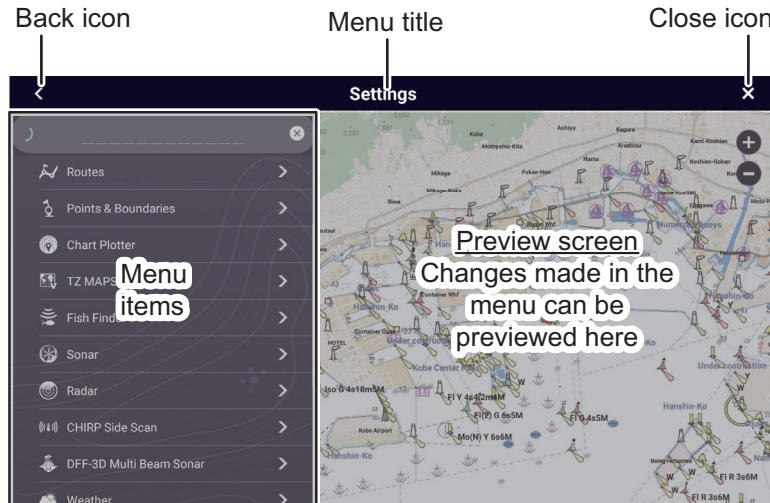

- Depending on the menu item selected, the following operations are available:

- ON/OFF flipswitch.
 ON 
 OFF 

Tap to switch between ON and OFF to activate or deactivate the function.

- Sliderbar and keyboard icon. 

Drag the slider bar to adjust the setting. Settings may also be adjusted using the software keyboard for direct input.

- Keyboard icon. 

Referring to the figure below, use the software keyboard to input alphabet or numeric characters.

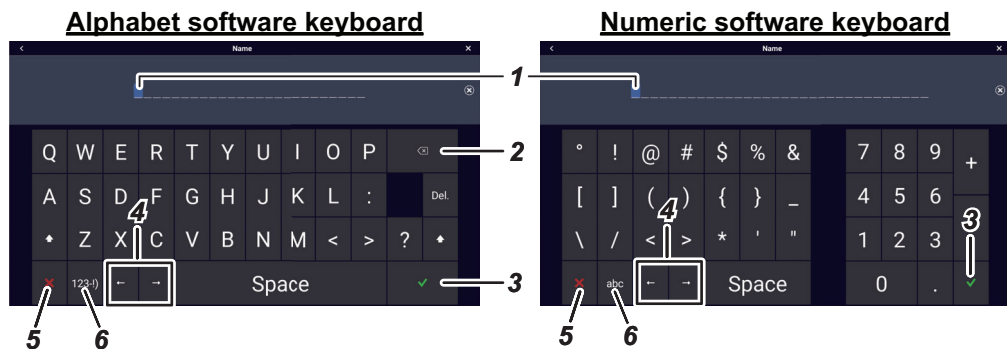

No.	Description
1	Cursor position is highlighted.
2	Backspace/Delete. Tap to erase one character at a time.
3	Enter button. Tap to complete character input and apply changes.
4	Cursor keys. Tap to move the cursor left/right.
5	Cancel button. Aborts character entry. No changes are applied.
6	Tap to switch between alphabet and numeric keyboards (where available).

- Tap the close button (X) at the top right-hand side of the screen to exit.

3.1 How to Manage Device Communication

When a new device is detected, the following pop-up message appears. Select [ALLOW] to allow the communication with the device. If an unauthorized device is detected, select [DENY] to prohibit the communication.

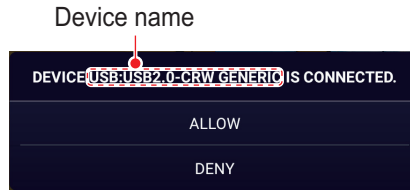

For the device to be prohibited the communication, the prohibition icon (🚫) appears to the left of the sensor name on the sensor list. To show the sensor list, open the home page → [Settings] → [Initial Setup] → [Data Sensors] → [Sensor List].

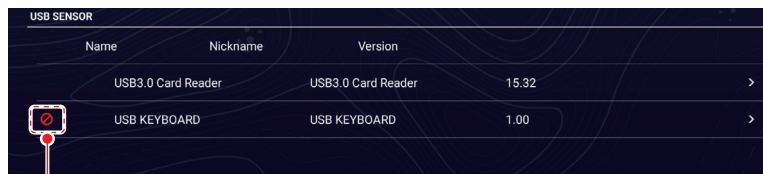

Indicates that the communication of this device is prohibited.

To allow the communication, tap the device on the sensor list then turn on [Permission to use]*.

*: When the PIN code lock is activated, enter the PIN code to change the setting.

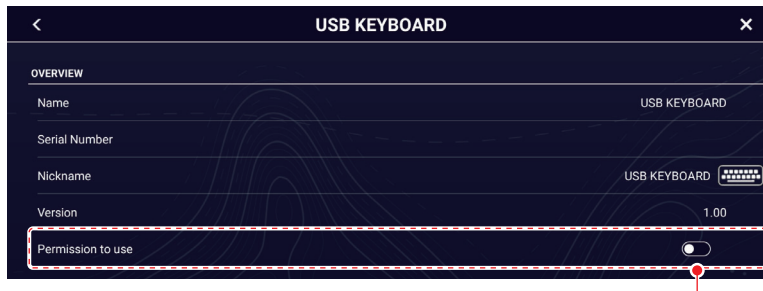

Turn on this setting to allow the communication with the device.

3.2 How to Set Time Zone, Time Format and Language

Before setting up your equipment, select the time zone, language and units to use on your equipment as shown below.

1. Tap the [FURUNO] icon () to show the home screen and display mode settings.
2. Tap [Settings] to show the [Settings] menu.
3. Tap [General] to show the [General] menu.
4. Tap [Local Time Offset], and a numerical keyboard appears.
5. Input the time difference (using 15-minute intervals) between local and UTC, then tap [✓].
6. Tap [Time Format] to show its option window.
7. Select how to display time, in 12- or 24-hour format. [Auto] automatically inserts AM, PM indication in 24-hour clock, when the language is English.
8. Tap [<] at the top left of the screen to return to the [General] menu.
9. Tap [Language] to show the [Language] menu.

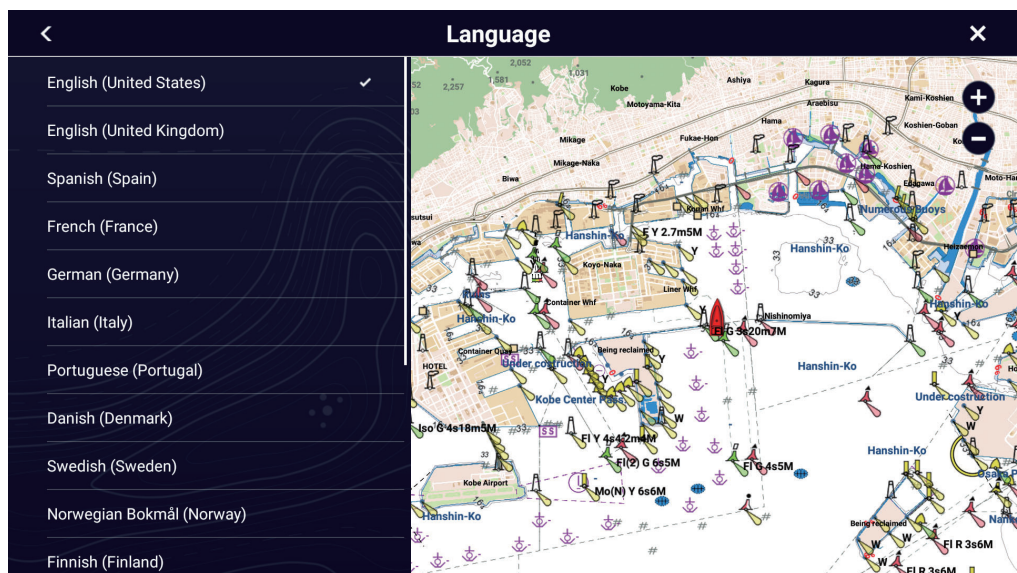

10. Tap the appropriate language to use. The unit will display a confirmation message. Tap [OK] to restart the unit and apply the new language settings. This process takes approximately five minutes to optimize the system for the new language setting. When the process is completed (five minutes later), the system restarts automatically.

3.3 How to Set Units of Measurement

1. Tap the [FURUNO] icon () to show the home screen and display mode settings.
2. Tap [Settings] to show the [Settings] menu.
3. Scroll the main menu to display [Units], then tap [Units].
4. Referring to the table below, set the units to show on the display.

Menu item	Description	Options (setting range)
[Bearing Display]	Adjust the bearing display format.	[Magnetic], [True]
[True Wind Calculation Reference]	Set the reference for calculating true wind speed/angle.	[Ground], [Surface]
[Position Format]	Set the display format for position (Latitude/Longitude).	[DDD°MM.mmmm'], [DDD°MM.mmm'], [DDD°MM.mm'], [DDD°MM'SS.ss"], [DDD.dddddd°], [Loran-C], [MGRS]
[Loran C Station & GRI]	Available when [Position Format] is selected to [Loran-C].	Set Loran C station and GRI combination.
[Short/Long Change Over]	Set the distance at which to change between short and long range.	0.0 to 2.0 (NM)
[Range (Long)]	Set the unit of measurement for long distances.	[Nautical Mile], [Kilometer], [Mile]
[Range (Short)]	Set the unit of measurement for short distances.	[Foot], [Meter], [Yard]
[Depth]	Set the unit of measurement for depth.	[Foot], [Meter], [Fathom], [Passi Braza]
[Height/Length]	Set the unit of measurement for height and length.	[Foot], [Meter]
[Fish Size]	Set the unit of measurement for fish sizes.	[Inch], [Centimeter]
[Temperature]	Set the unit of measurement for temperature.	[Fahrenheit Degree], [Celsius Degree]
[Boat Speed]	Set the unit of measurement for boat speed.	[Knot], [Kilometer per Hour], [Mile per Hour], [Meter per Second]
[Wind Speed]	Set the unit of measurement for wind speed.	[Knot], [Kilometer per Hour], [Mile per Hour], [Meter per Second]
[Atmospheric Pressure]	Set the unit of measurement for atmospheric pressure.	[HectoPascal], [Millibar], [Millimeter of Mercury], [Inch of Mercury]
[Oil Pressure]	Set the unit of measurement for oil pressure.	[KiloPascal], [Bar], [Pound per Square Inch]
[Volume]	Set the unit of measurement for tank volume.	[Gallon] (Gallon & Gallon/hour), [Litre] (Litre & Litre/hour)
[Reset Default Page Settings]	Restore default unit settings.	[OK], [Cancel]

3.4 Initial Setup

This section shows you how to set your system according to the sensors you have connected.

Note: Some units are set to metric in this section, actual setting ranges vary depending on the unit of measurement set in the [Units] menu.

1. Tap the [FURUNO] icon () to show the home screen and display mode settings.
2. Tap [Settings] to show the [Settings] menu.
3. Scroll the main menu to display [Initial Setup], then tap [Initial Setup] to show the [Initial Setup] menu.
4. Referring to the following sections, set your equipment.



3.4.1 [Boat Information] menu

Menu item	Description	Options (setting range)
[Boat Height]	Set the height of your boat.	0 (m) to 999 (m)
[Boat Width]	Set the width of your boat.	0 (m) to 999 (m)
[Boat Length]	Set the length of your boat.	0 (m) to 999 (m)
[Boat MMSI]	Set the MMSI for your boat (used for fleet tracking function only).	
[Boat Name]	Set the name for your boat (used for fleet tracking function only).	
[Size of Own Ship Icon]	Set the size of own ship icon.	50 to 150
[Depth Display]	Select the start point for depth measurement.	[Under Keel], [Under Sea Level]
[External Transducer Draft]	Set the draft for external transducers other than internal fish finder, networked or multi-beam sonar. For internal/network transducers , set the draft from Home screen → [Settings] → [Fish Finder] → [Fish Finder Initial Setup] → [Transducer Draft]. For multi-beam sonars , set the draft from Home screen → [Settings] → [DFF-3D Multi-beam Sonar] → [Initial Setup] → [Transducer Draft].	0.0 (m) to 99.9 (m)
[Keel Draft]	Set the keel draft.	0.0 (m) to 99.9 (m)
[Engine Count]	Set the number of engines.	0 to 6
[Reset Default Page Settings]	Resets [Boat Information] menu settings to default.	[OK], [Cancel]

3. HOW TO SET UP THE EQUIPMENT

3.4.2 [Instruments Setup] menu



Menu item	Description	Options (setting range)
[Engine & Tank Automatic Setup]		
The system automatically detects active engines and tanks connected to the same network.		
[Engine & Tank Manual Setup]		
The manual set up method should only be used if the automatic setup did not correctly detect your engines or tanks.		
		
[Nickname]	Change the nickname for the engine or tank.	
[Used For Propulsion]	Select which engine/tank is used to calculate the distance which may be traveled using the remaining fuel. [On] uses the engine/tank for calculations, [Off] ignores the engine/tank.	Off, On
[Reset]	Resets the engine/tank details to default.	
[Graphic Instruments Setup]		
[Maximum Boat Speed]	Set the transducer's maximum detectable speed.	1 (kn) to 99 (kn)
[Maximum Wind Speed]	Set the transducer's maximum detectable speed.	1 (kn) to 99 (kn)
[Minimum Depth]	Set the transducer's minimum detectable depth.	1 (m) to 1999 (m)
[Maximum Depth]	Set the transducer's maximum detectable depth.	1 (m) to 2000 (m)
[Minimum Sea Surface Temperature]	Set the transducer's minimum detectable temperature.	0.00°C to 98.99°C
[Maximum Sea Surface Temperature]	Set the transducer's maximum detectable temperature.	0.01°C to 99.99°C
[Max. RPM]	Set the maximum rpm of your engine to show on the RPM display.	1 (rpm) to 20,000 (rpm)
[Red Zone Oil Pressure]	Set the starting value for the red zone area of the oil pressure meter.	0 (psi) to 143 (psi)
[Max. Oil Pressure]	Set the maximum oil pressure of your engine.	1 (psi) to 144 (psi)
[Min. Temperature]	Set the minimum temperature for your engine.	0.00°C to 99.00°C
[Red Zone Temperature]	Set the starting value for the red zone area of the engine temperature indicator.	0.01°C to 999.00°C

Menu item	Description	Options (setting range)
[Add Default CZone Pages]	Create, edit C-Zone pages.	
[CZone DIP Switch Settings]	Set this unit's DIP switches. For the service technician. Do not change the settings.	
[Instruments Theme]	Select the graphic theme for the instrument page. Display examples: [Instruments Theme] = [Modern]  Display examples: [Instruments Theme] = [Legacy] 	
[Reset Instrument Pages]	Resets all instrument pages to default.	[OK], [Cancel]
[Reset Default Page Settings]	Resets [Instruments Setup] menu settings to default.	[OK], [Cancel]

3.4.3 [Manual Fuel Management] menu

Menu item	Description	Options (setting range)
[Total Fuel Capacity]	Enter the total fuel capacity of your tank(s).	0 to 9,999 (L).
[Manual Fuel Management]	Set to On for manual fuel management. See the Operator's Manual.	Off, On
[Reset Default Page Settings]	Resets [Manual Fuel Management] menu settings to default.	[OK], [Cancel]

3.4.4 [Data Sensors] menu

Menu Item	Description	Options (setting range)
[Data Sources]	Select the source for each data to input to the system. If two or more sources are connected for a data, select one using the pull-down dialog box. The FURUNO products are shown at the upper part of the list.	
[Sensor List]	Show the information for sensors connected to your equipment. Tap the sensor to show the detailed information. You can edit the items with  icons on the right of the screen. Note 1: If you change an instance value, you need to restart its sensor. Note 2: If an unknown sensor appears on the sensor list, tap the sensor and check the detailed information. If it is an unauthorized sensor, turn off [Permission to Use]* to prohibit the communication. The prohibition icon () appears to the left of the sensor name on the sensor list.	

3. HOW TO SET UP THE EQUIPMENT

Menu Item	Description	Options (setting range)
[NMEA0183 Output]*	<ul style="list-style-type: none"> [Baud Rate]: Select the baud rate. [NMEA-0183 Version]: Select the version for NMEA 0183. 	<ul style="list-style-type: none"> [4,800], [9,600], [38,400] [1.5], [2.0], [3.0]
	[Sentences]: Select the sentences to output. Note: If the TTM sentence is received at the same time as another sentence, the constraints to communication bandwidth may cause a decrease in the number of TTM targets.	Off, On
[NMEA2000 PGN Output]*	Turn On for the PGN's (Parameter Group Number, NMEA 2000 message) to output from the NMEA 2000 port. Note: The default setting of some PGNs is "ON".	Off, On
[Sky View...]	Show the condition of GPS and GEO (WAAS) satellites on the [GPSSkyView] display. The bearing and elevation angle of all GPS and GEO-satellites (if applicable) in view of your receiver appear. For the serviceman. Note: The [GPS SkyView] display can also be shown by tapping the GPS icon (shown right) on the Home page.	
[GP330B WAAS Mode]	Turn On to use the WAAS mode for the corresponding GPS antenna.	Off, On
[WS200 WAAS Mode]		
[Reset Default Page Settings]	Resets [Data Sensors] menu settings to default.	[OK], [Cancel]

*: When the PIN code lock is activated, enter the PIN code to change the setting.

3.4.5 [Network Sensor Setup] menu

The [Network Sensor Setup] menu allows you to set up compatible FURUNO NMEA 2000 sensors. Calibrations and offsets applied in this menu are also applied to the sensor itself.

Tap the sensor to access its menus and settings. For details regarding the menu structure and set up of each sensor, see the appropriate operator's manual, supplied with the sensor.

Menu item	Description	Option (setting range)
[NAVpilot-300 (Processor...)]	When the NAVpilot-300 is connected in the NavNet TZtouchE network, you can setup the NAVpilot from this equipment. For details regarding each menu item, see the NAVpilot Operator's Manual.	
[FAX-30 Browser]	Show the Facsimile Receiver FAX-30 display.	
[FA-30 Browser]	Show the AIS Receiver FA-30 display.	
[FA-50 Browser]	Show the AIS Receiver FA-50 display.	
[SC-30] (only when the SC-30 is connected)		
[WAAS Mode]	Turn On to use the WAAS mode.	Off, On
[Heading Offset]	Enter the offset value for heading.	-180° to +180°
[Pitch Offset]	Enter the offset value for pitching.	-90° to +90°

3.4.6 [Data Offset] menu

Menu item	Description	Options (setting range)
[Heading]	Offset heading data.	-180.0° to +180.0°
[Speed Through Water]	Calibrate speed data. Enter amount in percentage.	-50% to +50%
[Wind Speed]	Offset wind speed data. Enter amount in percentage.	-50% to +50%
[Wind Angle]	Offset wind angle data.	-180° to +180°
[Sea Surface Temperature]	Offset sea surface temperature data.	-10°C to +10°C
[Reset Default Page Settings]	Resets [Data Offset] menu settings to default.	[OK], [Cancel]

3.4.7 [GPS Position] menu

Menu item	Description	Options (setting range)
[Longitudinal (from bow)]	Referring to the figure on the right, enter the GPS antenna positioning bow-stern (Longitudinal) and port-starboard (Lateral) position from the origin.	0 (m) to 999 (m)
[Lateral (-Port)]		-99 (m) to +99 (m) Port-side is negative, Starboard-side is positive.
[Reset Default Page Settings]	Resets [GPS Position] menu settings to default.	[OK], [Cancel]



3.4.8 [Data Damping] menu

Menu item	Description	Options (setting range)
[COG & SOG]	Set data damping time. The lower the setting the faster the response to change.	0 to 59 seconds
[Heading]		
[Speed Through Water]		
[Wind Speed & Angle]		
[Rate of Turn]		
[Reset Default Page Settings]	Resets [Data Damping] menu settings to default.	[OK], [Cancel]

3.4.9 [IF-NMEAFl Setup] menu

Menu item	Description	Options (setting range)
[Select IF]*	Select [IF-NMEAFl] to set the analog data that is input from the IF-NMEAFl. The setting is made after restarting the IF-NMEAFl.	
[Category]	Select the use (category) for this sensor.	[Wind], [ST800_850], [Fuel], [FreshWater], [WasteWater], [LiveWell], [Oil], [BlackWater]
[Resistance Full]	The resistance, in Ohms, when the tank is full.	0 (ohm) to 500 (ohm)
[Resistance Mid]	The resistance, in Ohms, when the tank is half full.	0 (ohm) to 500 (ohm)
[Resistance Empty]	The resistance, in Ohms, when the tank is empty.	0 (ohm) to 500 (ohm)
[Capacity]	The capacity of the tank.	0 (G) to 2650 (G)
[Fluid Instance]	Select the NMEA instance for the tank.	000 to 254
[Self test]	Test results are displayed.	

3. HOW TO SET UP THE EQUIPMENT

Menu item	Description	Options (setting range)
[Set Hardware to Factory Default]	Resets the converter selected at [Select IF] to factory default.	[OK], [Cancel]
[Reset Default Page Settings]	Resets [IF-NMEA-FI Setup] menu settings to default.	[OK], [Cancel]

*: When the PIN code lock is activated, enter the PIN code to change the setting.

3.4.10 [Fusion] menu

Menu item	Description	Options (setting range)
[Connect to Fusion]	Connects to your Fusion equipment.	
[Fusion Auto Volume]	Turn On to allow the TZT9E/13E to control the FUSION volume automatically.	Off, On
[Minimum Speed]	Set the minimum speed threshold. Exceeding this speed activates volume auto control.	0.0 (kn) to 98.9 (kn)
[Maximum Speed]	Set the maximum speed threshold.	0.1 (kn) to 99.0 (kn)
[Volume Increase]	Set the amount of extra volume to output.	10% to 50%
[Reset Default Page Settings]	Resets [Fusion] menu settings to default.	[OK], [Cancel]

3.4.11 [Service/Self Test/Log] menu

Menu item	Description	Option (setting range)
[Synchronization Log]	Shows synchronization with devices connected to the network.	
[Enable NMEA2000 Log]	Turn On when using NMEA 2000 log.	Off, On
[NMEA2000 Log Storage Location]	Show the location where to store the log.	
[Quick Self Test]	Displays various details regarding the TZT9E/13E unit, radar and fish finder.	
[Certification Mark]	Displays relevant certification for this equipment.	
[Service]	For the service technician.	
[Reset Default Page Settings]	Resets [Service/Self Test/Log] menu settings to default.	[OK], [Cancel]

3.4.12 [Home Page] menu

Menu item	Description	Options (setting range)
[Factory Reset]	Click [OK] to restore the [HOME] screen's default settings.	[OK], [Cancel]

3.4.13 Other [Initial Setup] menu items

Menu item	Description	Option (setting range)
[Chart Master Device]	Turn On to use this unit as the master, Off to use this unit as a slave. Note 1: If two or more TZT units are connected in the same network, set the chart master on only one TZT unit. Note 2: When two or more TZT units are connected in the same network, do not change this setting after completing the setup. If changed, it is necessary to obtain a new unlock code. For how to obtain a new unlock code, see the Operator's Manual.	
[System ID]	The system ID for this device within the network.	

Menu item	Description	Option (setting range)
[Update Network Equipments]	For the service technician.	
[Reset Default Settings]	Resets [Initial Setup] menu settings to default.	[OK], [Cancel]

3.5 How to Set Up the Radar (For the service technician only)

3.5.1 Radar source setting

1. Tap the [FURUNO] icon () to show the home screen and display mode settings.
2. Tap [Settings], then tap [Radar].
3. Tap [User Settings] → [Radar Source], then select the appropriate radar sensor.
Note: If a DRS sensor is connected but does not appear in the [Radar Source] list, close the list and open it again. The name of the DRS sensor should appear with a check mark, as in the example below.



3.5.2 [Radar Initial Setup] menu

1. Tap the [FURUNO] icon () to show the home screen and display mode settings.
2. Tap [Settings], then tap [Radar].
3. Tap [Radar Initial Setup].
4. Referring to the table which follows, set up the radar.

Menu item	Description	Options (setting range)
[Own Ship Icon]	Show or hide the own ship icon on the radar display.	Off, On
[Bearing Scale Mode]	Select the bearing scale mode. There are two types of mode: true and relative. The behavior changes depending on the orientation mode. <u>Head up mode</u> <ul style="list-style-type: none"> • [Relative]: Bearing scale is fixed and “0°” is at the top of the screen. • [True]: The own ship icon remains fixed and the bearing scale rotates according to the movement of your ship. <u>North up mode</u> <ul style="list-style-type: none"> • [Relative]: Bearing scale rotates according to the movement of your ship. • [True]: Bearing scale is fixed and “0°” is at the top of the screen. 	[True], [Relative]

3. HOW TO SET UP THE EQUIPMENT

Menu item	Description	Options (setting range)
[EBL Reference]	You can select the EBL reference from [True] or [Relative]. [True] means the bearing is in reference to the north. [Relative] means the bearing is relative to the heading of your ship. True bearing requires a heading sensor.	[True], [Relative]
[Antenna Rotation]	Select the speed of antenna rotation. Not available (greyed out) with the radar sensor DRS4DL+.	[Auto], [24 RPM]
[Antenna Heading Align]	See section 3.5.3.	-179.9° to +180.0°
[Main Bang Suppression]	If main bang appears at the screen center, slide the circle icon so that the main bang disappears, while watching the radar echo at the left-hand side of the display.	0 to 100
[Enable Sector Blanking]	Up to two sectors may be selected for blanking (no transmission). Select [ON] to enable this feature. Set the start and end angles (0° to 359°).	Off, On
[Enable Sector 2 Blanking]		
[Position from Bow]	Referring to the figure on the right, enter the radar antenna positioning bow-stern (Longitudinal) and port-starboard (Lateral) position from the origin.	0 m to 999 m
[Position from Port]		-99 m to +99 m Port-side is negative, Starboard-side is positive.
[Height from Surface]	Select the height of the antenna above the waterline. Not available (greyed out) with the radar sensor DRS4DL+.	[Under 3m], [3m-10m], [Over 10m]
[Antenna Length]	Set the antenna radiator length. Not available (greyed out) with the radar sensor DRS4DL+, DRS2D-NXT, DRS4D-NXT, DRS4D X-Class, DRS4DL X-Class.	[1.0 m], [1.2 m], [1.8 m]
[Auto Tuning]	Enable/disable auto tuning for the connected radar. Not available (greyed out) with the radar sensor DRS2D-NXT, DRS4D-NXT, DRS6A-NXT, DRS12A-NXT, DRS25A-NXT.	Off, On
[Tuning Source]	Select a display in the dual range display to manually tune. Not available (greyed out) with the radar sensor DRS4DL+, DRS2D-NXT, DRS4D-NXT, DRS6A-NXT, DRS12A-NXT, DRS25A-NXT.	[Range1], [Range2]
[Manual Tuning]	Manually tune the radar.	-50 to 50
[Radar Monitoring]	Display various information regarding the connected radar.	
[Radar Optimization]	Automatically adjust magnetron output and tuning for the connected radar. Available when the [TX/STBY] setting is [ON]. Do not change these settings. Not available (greyed out) with the radar sensor DRS2D-NXT, DRS4D-NXT, DRS6A-NXT, DRS12A-NXT and DRS25A-NXT. Note 1: For the service technician only. Note 2: The service technician performs this whenever the magnetron is replaced.	



Menu item	Description	Options (setting range)
[ARPA Advanced Settings]	For service technician only. Do not change these settings. This item is available when [TX/STBY] is [ON]. Not available (greyed out) with FAR-2xx8 series, FAR-2xx7 series and FAR-15x8 series radar antennas.	
[TX Channel]	Select [1], [2] or [3], the channel where the interference is smallest. See the operator's manual for details. Available with the radar sensor DRS2D-NXT, DRS4D-NXT, DRS6A-NXT, DRS12A-NXT and DRS25A-NXT.	[Auto], [1], [2], [3]
[Auto acquire by Doppler]	When turning On, approaching targets (ships, rain clutter, etc.) within 3 NM from own ship are automatically acquired by the Doppler calculated from the radar echo. See the operator's manual for details. Available with the radar sensor DRS2D-NXT, DRS4D-NXT, DRS6A-NXT, DRS12A-NXT and DRS25A-NXT.	Off, On
[Reset Default Page Settings]	Resets [Radar Initial Setup] menu settings to default.	[OK], [Cancel]

3.5.3 How to align the antenna heading

You have mounted the antenna unit facing straight ahead in the direction of the bow. Therefore, a small but conspicuous target dead ahead visually should appear on the heading line (zero degrees).

In practice, you will probably observe some small bearing error on the display because of the difficulty in achieving accurate initial positioning of the antenna unit. The following adjustment will compensate for the error.

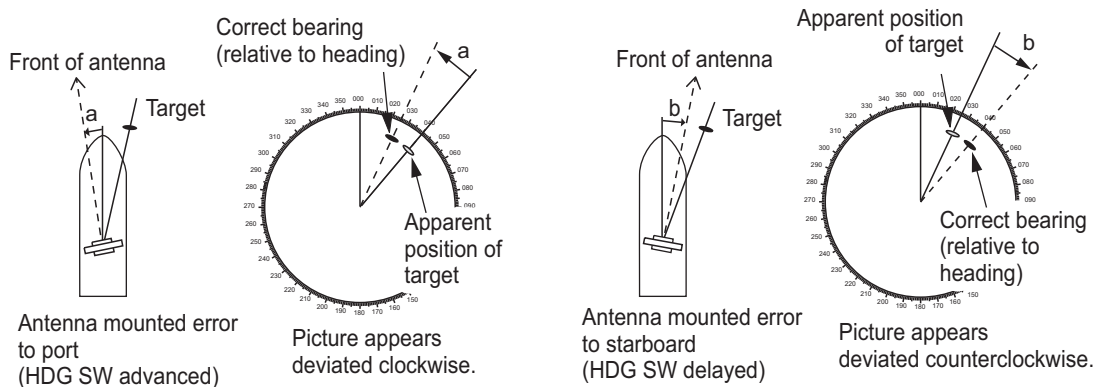

- Set your radar with 0.125 and 0.25 NM range and the head up mode. You can select a range by using the pinch action. The range appears at the bottom right of the screen. Range may also be selected using the slide bar displayed on the right-hand side of the radar display area. Drag the bar up to zoom in, or down to zoom out.

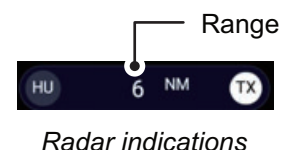
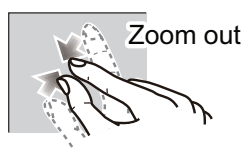
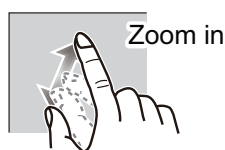

Radar indications

- Turn the vessel's bow toward a target.

3. HOW TO SET UP THE EQUIPMENT

3. Tap the [FURUNO] icon () to show the home screen and display mode settings.
4. Tap [Radar] to show the [Radar] menu.
5. Tap [Radar Initial Setup] → [Antenna Heading Align].
6. Key in an offset value (setting range: -179.9° to $+180^{\circ}$) that puts the target at the very top of the screen, then tap the ✓ icon.
 - + : rotate echo in clockwise direction
 - : rotate echo in counterclockwise direction
7. Confirm that the target echo is displayed at correct bearing on the screen.

3.6 How to Set Up the Fish Finder

When using the built-in fish finder of this unit or the NavNet TZtouch series unit in the same network, or connecting a network sounder (BBDS1 or DFF series), set up the fish finder/sounder as shown in this section.

3.6.1 Fish finder source setting

1. Tap the [FURUNO] icon () to show the home screen and display mode settings.
2. Tap [Settings], then tap [Fish Finder].
3. Tap [User Settings] → [Fish Finder Source], then select the fish finder to use. Select from the network fish finder (BBDS1, DFF1, DFF3, DFF1-UHD, DFF1UHD+, DFF3-UHD), the built-in fish finder of this unit, or NavNet TZtouch series unit on the same network. Setting options for this menu item depends on the equipment connected to this unit.

3.6.2 [Fish Finder Initial Setup] menu

1. Tap the [FURUNO] icon () to show the home screen and display mode settings.
2. Tap [Settings] → [Fish Finder] → [Fish Finder Initial Setup].
3. Refer to the table below to set up the fish finder.

Note 1: Some menu items are restricted to certain external depth sounders and some menu items may not be available when using the internal depth sounder.

Note 2: For DFF-3D setup instructions, see the DFF-3D operator's manual.

Menu item	Description	Options (setting range)
[Transducer Setup]	Setup Transducer and Motion Sensor. See section 3.6.3 and section 3.6.4.	

3. HOW TO SET UP THE EQUIPMENT

Menu item	Description	Options (setting range)
[Preset Frequency Setup]	<p>Set to change the TX center frequency and CHIRP width. Please refer to the instruction manual for details.</p> <p>Note: This menu is available when the fish finder source is as follows:</p> <ul style="list-style-type: none"> • Network fish finder DFF3-UHD/DFF1UHD+ (DFF3-UHD program version: 0252480-02.04 or later, DFF1UHD+ program version: 0252495-25.21 or later). • Network-installed NavNet TZtouch3 with DI-FFAMP (TZT9F not included) • DI-FFAMP (TZT12F/19F/19F) • TZTXFF (built-in fish finder of TZT10X/13X/16X) • TZTEFF (built-in fish finder of TZT9E/13E) 	[Preset Frequency 1 Setup], [Preset Frequency 2 Setup], [Preset Frequency 3 Setup]
[Zero Line Rejection]	<p>When you turn the zero line (transmission line) rejection on, the line is not shown, which allows you to see fish echoes near the surface. The width of the line changes with the transducer used and installation characteristics. If the width of the line is 1.4 m or more, set the [Zero Line Range] to higher than 1.4.</p> <p>Note: When any of the models listed below are set as the [Fish Finder Source], and this menu item is set to On, set the [Zero Line Range] as shown below.</p> <ul style="list-style-type: none"> • DFF3 • DFF3-UHD • DFF1UHD+ • DI-FFAMP (TZT12F/19F/19F) • TZTXFF (built-in fish finder of TZT10X/13X/16X) • TZTEFF (built-in fish finder of TZT9E/13E) 	Off, On
[Zero Line Range]	<p>When [Zero Line Rejection] is On, you can set the removal range for the zero line. Available when DFF3, DFF3-UHD, DFF1UHD+, TZTEFF (built-in fish finder of TZT9E/13E), TZTXFF (built-in fish finder of TZT10X/13X/16X), or DI-FFAMP (TZT12F/16F/19F) is selected as the fish finder source. If the zero line trail is long, set the value to a larger number. If the line still does not disappear, reduce the transmission power. The default setting is 2.0.</p>	DFF3: 1.4 to 2.5 Other than DFF3: 1.4 to 3.8
[Transducer Draft]	<p>Set the distance between the transducer and the draft line to show the distance from the sea surface.</p>	0.0m to 99.9m
[Salt Water]	<p>Turn On if you use this equipment in salt water.</p>	Off, On
[Transmission Format]	<p>Select whether to transmit high and low frequencies simultaneously, or separately with a time delay. Normally, use [Parallel], which transmits the frequencies simultaneously. If you encounter interference near the bottom, select [Sequential A] or [Sequential B] in order to suppress the interference.</p> <p>Note: Shown with connection of DFF3-UHD.</p>	[Parallel], [Sequential A], [Sequential B]

3. HOW TO SET UP THE EQUIPMENT

Menu item	Description	Options (setting range)
[Transmission Power]	<p>If a fish finder of the same frequency is being used nearby, interference noise may appear on the screen. By communicating with other users and adjusting the transmit power, interference noise can be reduced. The setting range depends on the unit as follows:</p> <ul style="list-style-type: none"> • TZTEFF (with built-in fish finder TZT9E/13E), TZTXFF (with built-in fish finder TXT10X13X/16X), DFF1UHD+, or TZT9F/12F/16F/19F without DI-FFAMP. For TZT9F/12F/16F/19F, the settings are [Min], [Max]. • DFF3-UHD: [Auto], [Man] (0 (TX off) to 10 (max)). • When a DI-FFAMP (TZT12F/16F/19F) is connected and a CHIRP transducer is selected: [Auto], [Man] (1(TX off) to 10 (max)). • DFF1-UHD: [Off], [Min], [Auto] • DFF1, BBDS1, DFF3: 0 (off) to 10 (max) 	
[External KP]	Turn On to synchronize with external sounder's keying pulse.	Off, On
[Bottom Level HF] [Bottom Level MF] [Bottom Level LF]	<p>The default bottom level setting (0) determines that two strong echoes received in sequence are bottom echoes. If the depth indication is not stable in the default setting, adjust the bottom level here. If vertical lines appear from the bottom echo in the bottom lock display, lower the bottom level to erase the vertical lines.</p> <p>If you can not identify the fish near the bottom from the bottom echo, increase the bottom level.</p>	-40 to +40
[Gain Offset HF] [Gain Offset MF] [Gain Offset LF]	If the auto gain offset is wrong, or there is a difference in the gain between the low and high frequencies, set an offset here to balance auto gain for the two frequencies.	-50 to +50
[Auto Gain Offset HF] [Auto Gain Offset MF] [Auto Gain Offset LF]	If the auto gain offset is wrong, or there is a difference in the gain between the low and high frequencies, set an offset here to balance auto gain for the two frequencies.	-5 to +5
[STC HF] [STC MF] [STC LF]	<p>Adjust the low (LF), middle (MF) or high (HF) STC frequency. See the operator's manual for details.</p> <p>Note: Available with DFF3, DFF1-UHD, DFF1UHD+, DFF3-UHD, DI-FFAMP (TZT12F/16F/19F).</p>	0 to +10
[TX Pulse HF] [TX Pulse MF] [TX Pulse LF]	<p>The pulse length is automatically set according to range and shift, however it can also be set manually. Use a short pulse for better resolution and a long pulse when detection range is important. To improve resolution on zoom displays, use [Short 1] or [Short 2].</p> <ul style="list-style-type: none"> • [Short 1] improves the detection resolution, but the detection range is shorter than with [Std] (pulse length is 1/4 of [Std]). • [Short 2] raises the detection resolution, however detection range is shorter (pulse length is about 1/2 of [Std]) than [Std]. • [Std] is the standard pulse length, and is suitable for general use. • [Long] increases the detection range but lowers the resolution (about 1/2 compared to the [Std] pulse length) <p>Note: Available with DFF3, DFF3-UHD, or when a narrow-band transducer is used with DI-FFAMP (TZT12F/16F/19F).</p>	[Short1], [Short2], [Standard], [Long]

Menu item	Description	Options (setting range)
[RX Band HF] [RX Band MF] [RX Band LF]	Set the bandwidth for low (LF) or high (HF) frequency. The RX bandwidth is automatically set according to pulse length. To decrease noise, select [Narrow]. For better resolution, select [Wide]. Note: Shown with connection of DFF3, DFF3-UHD.	[Narrow], [Standard], [Wide]
[Temperature Port]	Set the data source for water temperature. <ul style="list-style-type: none"> • [MJ]: Use the temperature/speed sensor for data. • [Low Frequency]: Use the LF sensor for data. • [High Frequency]: Use the HF sensor for data. Note: Shown with connection of DFF3, DFF1-UHD, DFF1UHD+.	[MJ], [Low Frequency], [High Frequency]
[Reset Default Page Settings]	Restore the [Fish Finder Initial Setup] menu settings to default.	[OK], [Cancel]

3.6.3 [Transducer Setup] menu

For motion sensor related settings, see section 3.6.4.

Note: Make sure that the unit is set to stand-by when setting up the transducer.

Menu item	Description	Options (setting range)
[Transducer Setup Type]	Select the type of transducer connected. When the connected sounder is a DFF1-UHD/ DFF1UHD+ and the transducer has a compatible TDID, [TDID] is automatically selected. Note: When the transducer model is changed or TDID is detected, the frequency and bandwidth set on [Manual] is to be reset. <ul style="list-style-type: none"> • [Manual]: Manually set up the transducer. • [Model]: Select the appropriate transducer model (for FURUNO or AIRMAR transducers). 	[Manual] ^{*2} , [Model]
[Model Number]	Select the appropriate model number from the list. Note: Only available when [Transducer Setup Type] is set to [Model].	
[High Frequency Min] ^{*1}	Display the high frequency minimum.	
[High Frequency Max] ^{*1}	Display the high frequency maximum.	
[Low Frequency Min] ^{*1}	Display the low frequency minimum.	
[Low Frequency Max] ^{*1}	Display the low frequency maximum.	
[Reset Default Page Settings]	Reset the [Transducer Setup] menu settings to default.	[OK], [Cancel]

*1 Shown with connection of DFF3.

:

*2 Available when DFF1, BBDS1, DFF3, DFF1-UHD, DFF3-UHD, or DI-FFAMP is connected.

When [Transducer Setup Type] is set to [Model] and connected to DFF3

Menu item	Description
[High Frequency]	Set the frequency (kHz) of the connected high frequency transducer.
[Frequency Adjust HF]	Fine-tune the high-frequency TX frequency to eliminate interference (setting range: -50 to +50). Set to [0] where there is no interference.
[Low Frequency]	Set the frequency (kHz) of the connected low frequency transducer.

3. HOW TO SET UP THE EQUIPMENT

Menu item	Description
[Frequency Adjust LF]	Fine-tune the low frequency TX frequency to eliminate interference (setting range: -50 to +50). Set to [0] where there is no interference.

When [Transducer Setup Type] is set to [Model] and connected to DFF3-UHD

Menu item	Description	Options (setting range)
[TX Mode HF]	Band adjustment mode for center frequency and CHIRP frequency of the transducer connected to the high frequency side.	[Auto CHIRP], [FM (Manual CHIRP)], [CW (Fixed Frequency)]
[High Frequency]	Set the high frequency (kHz) of the transducer connected to the high frequency side.	
[Frequency Adjust HF]	If [FM (Manual CHIRP)] or [CW (Fixed Frequency)] is selected at [TX Mode HF], fine-tune the high-frequency TX frequency to eliminate interference (setting range: -50 to +50). Set to [0] where there is no interference.	
[CHIRP Width HF]	If [FM (Manual CHIRP)] is selected in [TX Mode HF], set the CHIRP frequency band of the transducer connected to the high frequency side.	
[TX Mode LF]	Band adjustment mode for center frequency and CHIRP frequency of the transducer connected to the low frequency side.	[Auto CHIRP], [FM (Manual CHIRP)], [CW (Fixed Frequency)]
[Low Frequency]	Set the low frequency (kHz) of the transducer connected to the low frequency side.	
[Frequency Adjust LF]	If [FM (Manual CHIRP)] or [CW (Fixed Frequency)] is selected at [TX Mode LF], fine-tune the low-frequency TX frequency to eliminate interference (setting range: -50 to +50). Set to [0] where there is no interference.	
[CHIRP Width LF]	If [FM (Manual CHIRP)] is selected in [TX Mode LF], set the CHIRP frequency band of the transducer connected to the low frequency side.	

When [Transducer Setup Type] is set to [Manual]

Menu item	Description	Options (setting range)
[High Frequency]	Set the kHz frequency for high frequency. Setting ranges vary depending on the transducer connected. Note: Shown with connection of DFF1, BBDS1, DFF3, DFF1-UHD, DFF1UHD+.	
[Transducer Power HF]	Set the transmission power for high frequency. Note 1: Shown with connection of DFF1, BBDS1, DI-FFAMP (TZT12F/16F/19F) or DFF3-UHD. Note 2: For DFF1-UHD or DFF1UHD+ users, when the connected transducer TDID is not supported by the DFF1-UHD/DFF1UHD+, the setting is fixed as [1000].	[600], [1000]
[Band Width (HF)]	Set the bandwidth for high frequency. Note: Shown with connection of DFF3.	
[Low Frequency]	Set the kHz frequency for low frequency. Setting ranges vary depending on the transducer connected. Note: Shown with connection of DFF1, BBDS1, DFF3, DFF1-UHD, DFF1UHD+.	

Menu item	Description	Options (setting range)
[Transducer Power LF]	Set the transmission power for low frequency. Note 1: Shown with connection of internal fish finder, DFF1, BBDS1, DI-FFAMP (TZT12F/16F/19F) and DFF3-UHD. Note 2: For DFF1-UHD or DFF1UHD+ users, when the connected transducer TDID is not supported by the DFF1-UHD/DFF1UHD+, the setting is fixed as [1000].	[600], [1000]
[Band Width (LF)]	Set the bandwidth for low frequency. Note: Shown with connection of DFF3.	

When [Transducer Setup Type] is set to [Manual] and connected to DFF3-UHD

Menu item	Description
[TX Volt HF]	Set the TX voltage (V) of the transducer connected to the high frequency side.
[TX Volt LF]	Set the TX voltage (V) of the transducer connected to the low frequency side.
[High Frequency]	Set the frequency (kHz) of the transducer connected to the high frequency side.
[Low Frequency]	Set the frequency (kHz) of the transducer connected to the low frequency side.
[TX Power HF]	Set the Power of the transducer connected to the high frequency side.
[TX Power LF]	Set the Power of the transducer connected to the low frequency side.

3. HOW TO SET UP THE EQUIPMENT

3.6.4 [MOTION SENSOR] menu

The [MOTION SENSOR] menu sets up the motion sensor, which provides for stable display of the seabed, schools of fish, etc. in moderate-to-rough seas.

Note 1: For connection of NMEA 0183 equipment to the TZT9E/13E, ask your FURUNO dealer to set up the equipment.

Note 2: To use the heaving function, the following settings are required at the satellite compass. For the setting procedure, see the Operator's Manual for your satellite compass. Settings for SC-30 are done from the [IF-NMEASC] menu, settings for SCX-20 is done from the [DATA OUT] menu.

	NMEA 0183	NMEA 2000
Sentence	ATT, HVE	–
Baud rate	38400 bps	–
Cycle	25 ms	–
PGN	–	Heave: 65280 Attitude: 127257

The [MOTION SENSOR] menu appears in the [Transducer Setup] menu when the [Heaving Correction] is activated in the [Fish Finder] - [User Settings] menu. If the satellite compass SC-30/33/50/70/110/130/SCX-20 is connected, set the distance between the antenna unit (or sensor) of the satellite compass and transducer (high and low if connected) here.

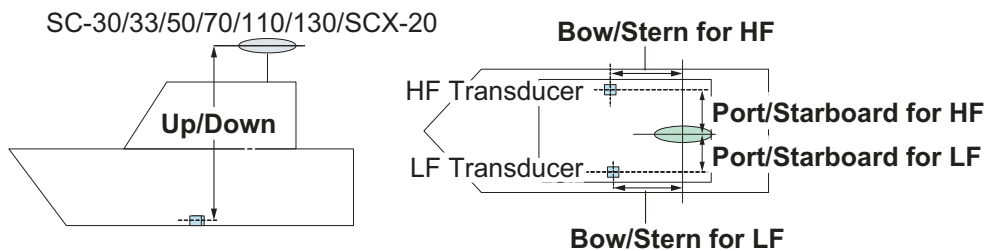

Menu item	Description	Options (setting range)
[Motion Sensor Type]	When the motion sensor is connected through the IF-NMEA2K2, select [NMEA0183]. Otherwise, select [NMEA2000].	[NMEA2000], [NMEA0183]
[Antenna Position Bow/Stern HF (LF)]	Set the distance from the antenna unit to the transducer in the bow-stern direction. If the transducer is located on the fore side, set a positive value.	-99 to +99
[Antenna Position Up/Down HF (LF)]	Set the distance from the transducer to the antenna unit in the vertical direction. If the transducer is located on the bow side, set a positive value.	-0.00 to +99.9
[Antenna Port/Starboard HF (LF)]	Set the distance from the antenna unit to the transducer in the port-starboard direction. If the transducer is located on the starboard side, set a positive value.	-99.9 to +99.9

3.6.5 Transducer mis-mount correction

If the DFF-3D or a CHIRP side scan compatible transducer is installed 180° in reverse (facing stern), turn on the following item:

- DFF-3D: [Settings] → [Multi Beam Sonar] → [Initial Setup] → [Transducer Setup] → [Transducer Mis-mount Correction] → [ON]
- CHIRP Side Scan: [Settings] → [CHIRP Side Scan] → [Transducer Mis-mount Correction] → [ON]

3.7 Wireless LAN Setting

3.7.1 How to connect to an existing wireless network

By connecting to an existing network, you may download software updates and weather information from the Internet.

1. Tap the [FURUNO] icon () to show the home screen and display mode settings.
2. Tap [Settings], then [General].
3. Tap [Connectivity], then [Wireless LAN Settings].
4. Tap [Wireless Mode].
5. Tap [Connect to existing LAN], then tap the [<] icon at the top left of the display.
6. Turn on [Wireless] in the [ENABLE WIRELESS] menu.
7. Tap [Scan] to scan the vicinity for accessible WLAN networks. Available networks are listed. To delete all WLAN networks, select [Forget All Available Networks].
8. Tap the appropriate WLAN network to show the following display.

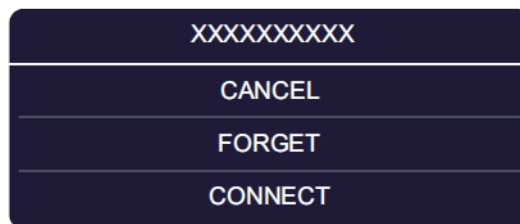

9. Tap [Connect], and the display shown in the right figure appears.
10. Use the software keyboard to enter the network key, then tap the [OK] button. To see what you have input, check [Show characters].

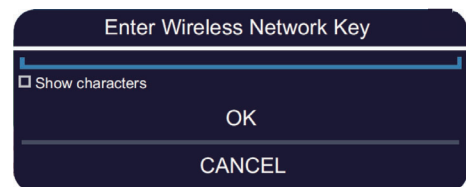



Note: If the network key is incorrect, an error message appears. Enter the correct key and tap [OK] again.

11. Tap [x] on the title bar to close the menu.

3.7.2 How to create a wireless LAN network

Smart devices connected to this wireless network may also connect directly to the unit, allowing use of the TZT9E/13E applications.

1. Tap the [FURUNO] icon () to show the home screen and display mode settings.
2. Tap [Settings] then [General], in that order.
3. Tap [Connectivity], then [Wireless LAN Settings].
4. Tap [Wireless Mode] in the [WIRELESS MODE] menu.
5. Tap [Create Local Network], then tap the [<] icon at the top left of the display.
6. Tap [Name] in the [LOCAL NETWORK SETTINGS] menu.
7. Using the software keyboard, name the unit, then tap the .
8. Tap [Password] in the [LOCAL NETWORK SETTINGS] menu.
9. Using the software keyboard, set the password, then tap the .
10. Tap [Local Network] in the [ENABLE LOCAL NETWORK] menu to activate the wireless network.
11. Your smart device may now be connected to the unit, through the network.
 - 1) From the smart device, select the network set at step 7.
 - 2) Input the password set at step 9.
12. Tap [×] on the title bar to close the menu.

3.8 How to Manage Charts

A TZ MAPS world chart is provided standard. For all other TZ MAPS charts you will need to purchase and load a chart license (for MM3D paid charts an unlock code is necessary). To share the system ID and unlock code between NavNet TZtouch series units connected within the same network, go the Home page on any unit → [Settings] → [Initial Setup] → turn on [Chart Master].

Note: If two or more NavNet TZtouch series devices share an unlock code or license, it is necessary to obtain a new unlock code when changing the Chart Master settings. For example, one unit is set as "main" (Chart master setting: On) and the other unit as "secondary" (Chart master setting: Off), you need to reacquire an unlock code. For information on how to re-obtain the unlock code, see the Operator's Manual.

3.8.1 How to update or add TZ MAPS charts

By connecting this device to the Internet and logging into My TimeZero™, you can purchase and renew a TZ MAPS chart license (valid for one year) and download chart data online. Downloaded chart data can be used even when offline by putting it on a microSD card and inserting it into the card slot on the left side of the device.

Note: Chart licenses are valid for one year, and during this period charts can be downloaded and updated. After the license period expires, you can continue to display the already downloaded charts. However, charts cannot be downloaded or updated. Also, functions that require license cannot be used. After the one-year period you can purchase a new chart license, which will be automatically renewed on a yearly basis. To

3. HOW TO SET UP THE EQUIPMENT

cancel the automatic renewal, go to your My TimeZero™ account, using the link below. The automatic renewal cannot be canceled from the device side.
<https://extranet.mytimezero.com/>

1. Home page → [Charts] → [TZ MAPS Store].

Tap here to highlight the selected area, on the right side of the screen (White background: Not purchased, Blue background: Purchased).

[Buy]: Not purchased, [✓]*: Purchased

*: When the license expires (one year), the indication changes to [Subscribe], and when you select and purchase a subscription, the indication changes to [Subscribed].

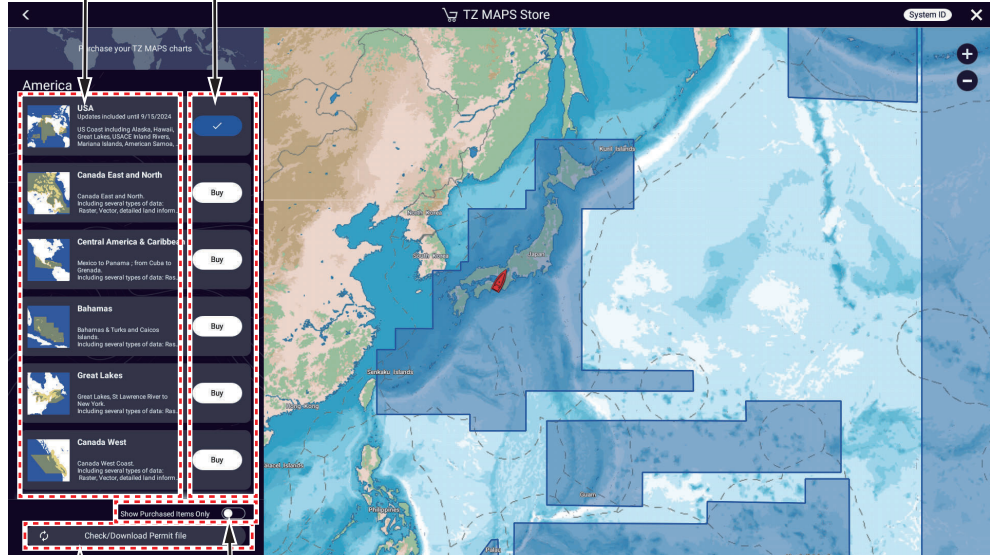

Turn ON to display only purchased charts.

Tap to check whether there is a license for the purchased chart. If there is, the file will be downloaded. After downloading, the [Buy] button of the purchased chart changes to a blue button, and you can then download the chart data for the purchased area ✓.

2. Tap the [Buy] button corresponding to the area to purchase. The message "Please wait, preparing your purchase" appears then the "buy screen" appears.

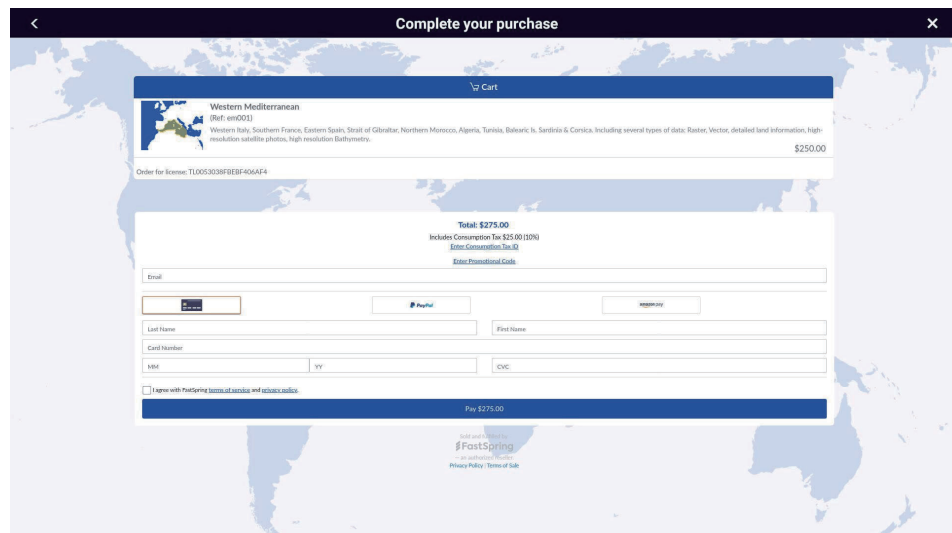

3. HOW TO SET UP THE EQUIPMENT

If you are not connected to the Internet, a quick-response code appears. Use your smartphone/tablet to read it and display the “buy screen”.

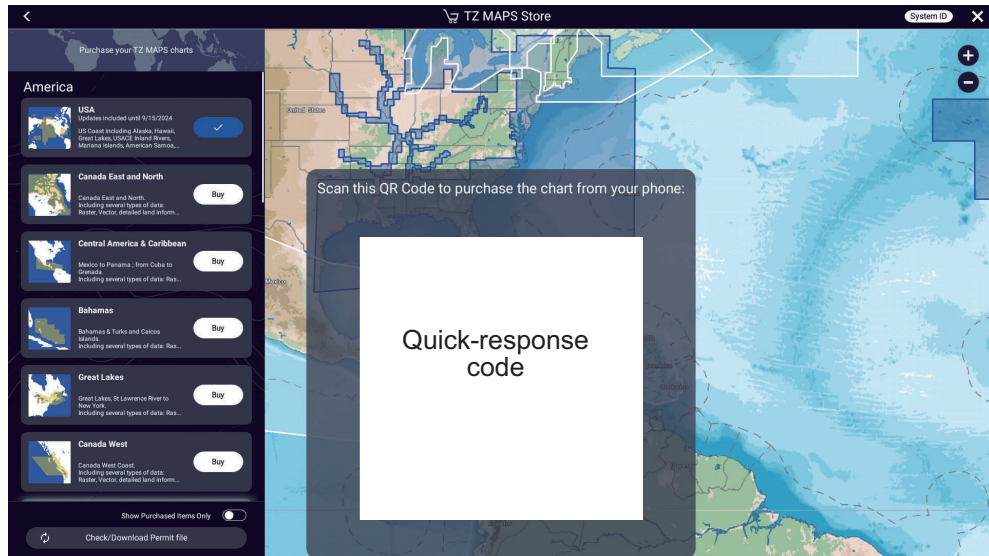

3. Select how to buy the chart.
4. Enter the required information.
5. Read the conditions of purchase, check ✓ to agree, then tap [Payment].
6. If you purchase a license using a quick-response code, a ZUC file is sent to your registered email address. Save the file to a USB flash memory, insert the memory into the USB port of this equipment, and read the file.

3.8.2 How to update TZ MAPS charts

If there is a new version of a downloaded chart data, there are two ways to update the chart, individually or all at once.

1. Home page → [Charts] → [TZ MAPS Update].

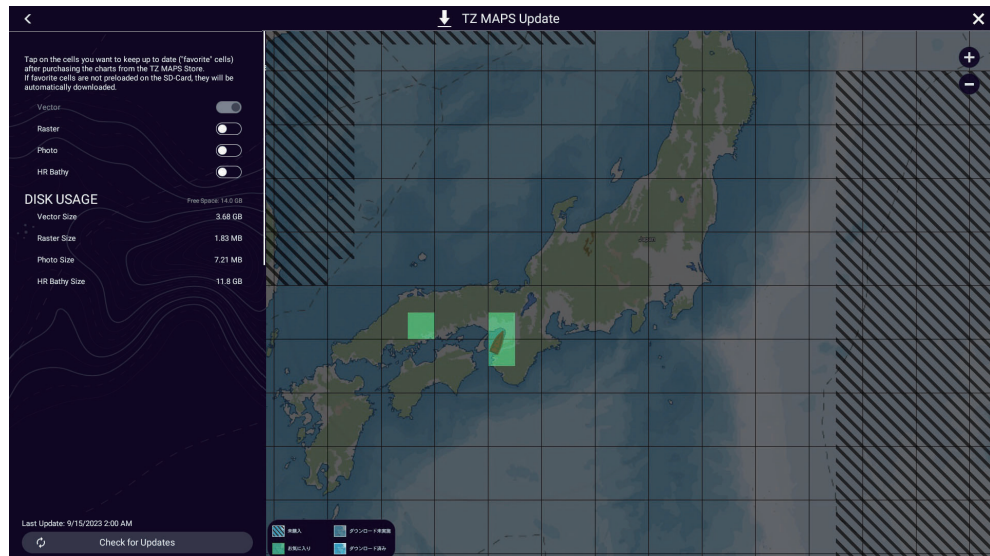

2. **Update chart data individually:** Tap the area you want to update.
Update chart data collectively: Tap [Check for Updates], at the bottom left corner of the screen. A “↓” icon appears in those areas that have [Favorites] status and can be updated. You can update multiple areas. Tap [Download Updates] at the bottom left corner of the screen. The download begins and progress is indicated at the bottom left corner of the screen. The [Download Updates] button changes to [Cancel] and then to [Downloaded] once the download is complete.
For individual download, the selected area is given [Favorites]* status. Tap [X] on the title bar to close the [TZ MAPS Update] screen and complete the process.



- *: Depending on the status of chart data, each area is classified and displayed into the following four types. [Favorites] switches between [Favorites] and [Downloaded] each time you tap an area.

3. HOW TO SET UP THE EQUIPMENT

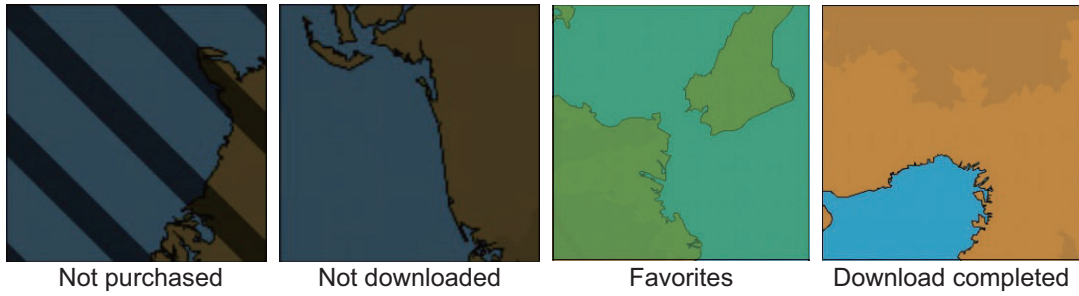

3.8.3 How to display the MM3D charts catalog

The chart catalog shows the MM3D charts, satellite photos, tidal information, etc. incorporated in this equipment. To display the MM3D charts catalog, Home page → [Charts] → [MM3D Charts Catalog].

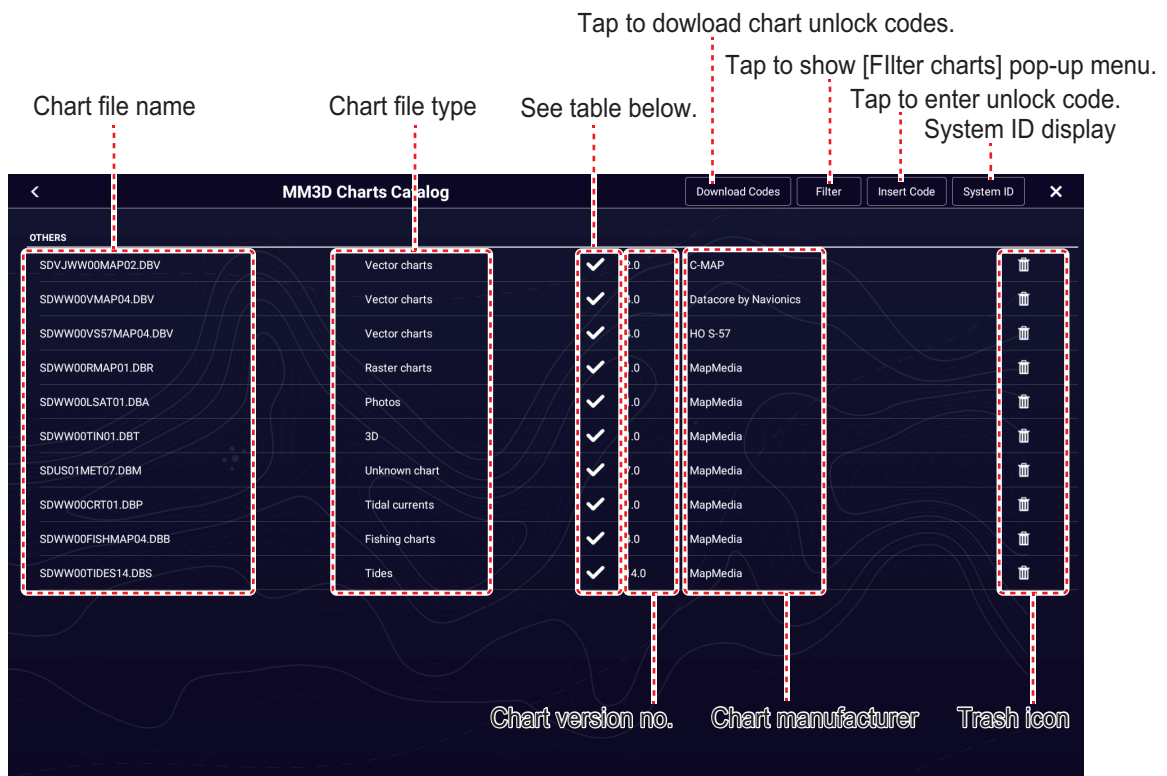



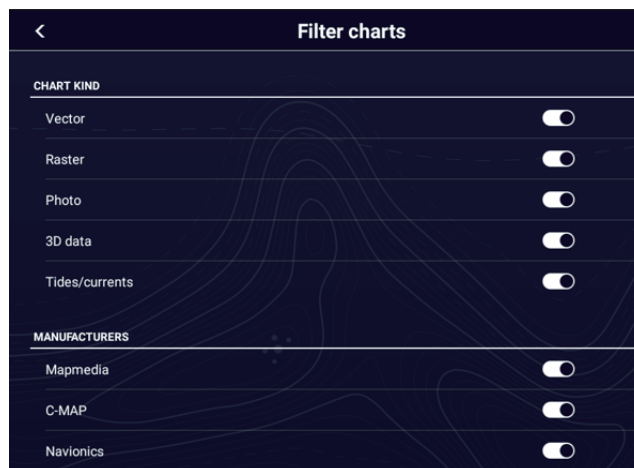

Chart status icon	Meaning	Chart status icon	Meaning
	Free chart. An unlock code is not necessary.		Paid chart. Unlock code entered.
	Paid chart. Unlock code is necessary to use the chart. Tap [Insert Code] at the top of the [Charts Catalog] screen. Enter the unlock code then tap [✓] to finish.		Chart cannot be used because it is corrupted.

How to hide unnecessary charts on the chart catalog list

1. Tap [Filter] on the chart catalog list title bar to show the [Filter charts] window.
2. Select [OFF] for the items that you want to hide. The factory setting shows all charts. To restore all charts, tap [Reset Filters].
Note: To restore all items to default (all ON), tap [Reset Filters].
3. Tap [<] on the title bar to return to the chart catalog list. [Filter] on the title bar changes to [Change Filter].
4. Tap [x] to finish and close the chart catalog list.



3.8.4 How to add MM3D charts

For information on how to obtain a chart and its unlock code, contact place of purchase or the nearest FURUNO branch or sales office. Put the chart you obtained into a microSD card and insert it into the card slot on the left side of the device. If you have added a paid chart, enter the unlock code (see the section 3.8.3).

3.8.5 How to MM3D charts

To delete charts, Home page → [Charts] → [MM3D Chart Catalog]. Tap the trash can icon (right edge of screen) corresponding to the chart to delete. You are asked if you are sure to delete the chart. Tap [OK] to delete the chart.

3.9 How to Set Up the SUZUKI Engine

This section covers the installation settings for your SUZUKI Gateway and SUZUKI engines. For details regarding the SUZUKI engine display, see your Operator’s Manual or eGuide.

To open the setting menu for the SUZUKI engine, do as follows:

1. Tap the [FURUNO] icon () to show the home screen.
2. Tap [Settings].
3. Drag the menu to display the [Suzuki Engine Setup] menu, then tap [Suzuki Engine Setup].
Note: The [Suzuki Engine Setup] menu appears when [Suzuki Mode] is set to [ON] on the service menu.
4. Tap [Installation...].
 A confirmation message appears.
5. Tap the [OK] button to open the [ENGINE INITIAL SETUP] menu, then do the procedures that follow.

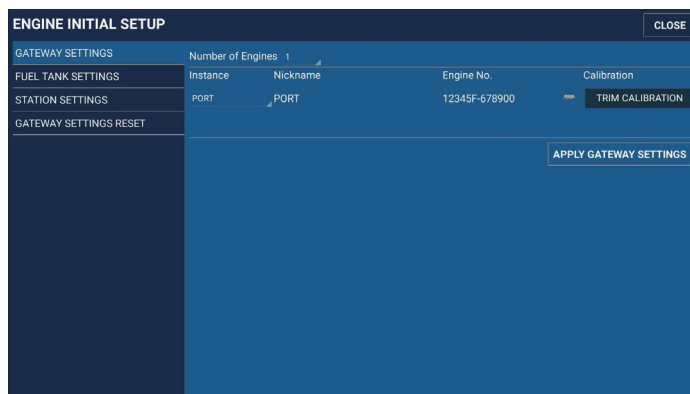

3.9.1 Engine installation

Before using the gateway, register the engine position and the engine serial number with gateway as shown below.

Number of engines

1. Tap [GATEWAY SETTINGS].
2. Tap [Number of Engines].

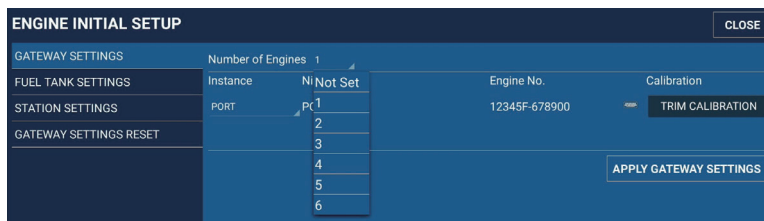

3. Select the number of engines.

Gateway Setting

1. Tap the [Instance] field of [Instance] for the gateway to be set.

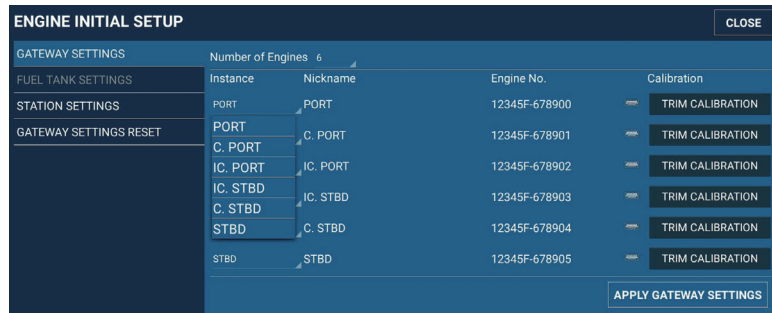

2. Select the engine position.

Note: The setting options shown on the drop-down list change depending on the [Number of Engines] setting.

Engine No.

1. Tap the keyboard icon to the right of the [Engine No.] field for the gateway to be set.



Confirm and apply the value or setting.
 Cancel input and close the keyboard.
 Move the cursor left or right.

2. Input the engine number, then tap the [OK] button to apply the setting.

Trim Calibration (Only Trim Sender Model)

1. Tap the [TRIM CALIBRATION] button to show the following message.

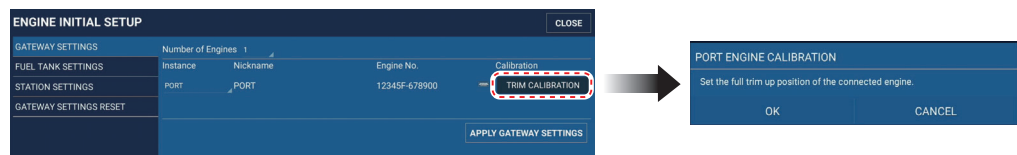

2. Set the full trim up position of the connected engine, then tap the [OK] button. The following message appears.

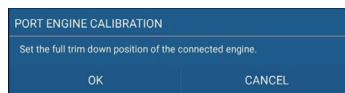

3. Set the full trim down position of the connected engine, then tap the [OK] button.
4. Tap the [APPLY GATEWAY SETTING] button to apply the settings on the [GATEWAY SETTINGS] menu. The following confirmation message appears.

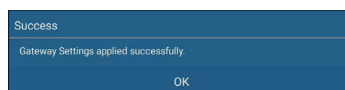

5. Tap the [OK] button to close the confirmation message.

3. HOW TO SET UP THE EQUIPMENT

Station Settings

1. Tap [STATION SETTINGS].
2. Tap [Station Setting].

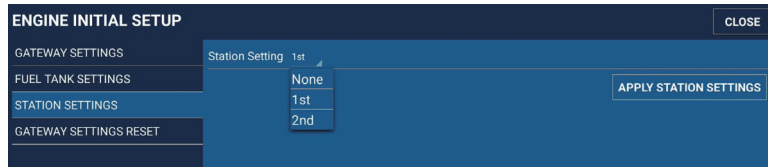

3. Select the station.
4. Tap the [APPLY STATION SETTINGS] button to apply the setting. The following confirmation message appears.

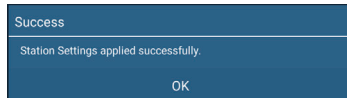

5. Tap the [OK] button to close the message.

Gateway settings reset

You can clear the followings settings and data for any of the connected Gateways and their connected engines. Typically this is not required unless you have replaced or added a new engine and/or Gateway.

- [Instance]
- [Engine No.]
- [QR Code]*
- [Log data]
- [Fuel Economy Average]
- [Engine Trip Time]
- [Engine Trip Distance]
- [Total Fuel Used]

*: QR code is registered trademark of DENSO WAVE INCORPORATED.

1. Tap [GATEWAY SETTING RESET].

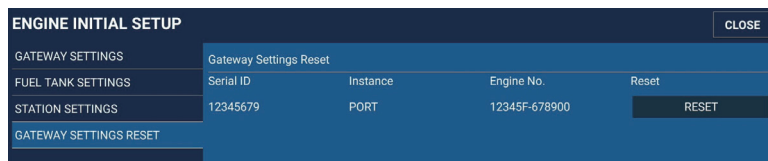

2. Tap the [RESET] button for the gateway to be reset. The following confirmation message appears.

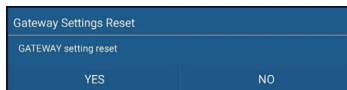

3. If necessary to reset, tap [YES]. If not necessary to reset, tap [NO].

Fuel Adapter Settings

1. Tap [FUEL TANK SETTINGS].

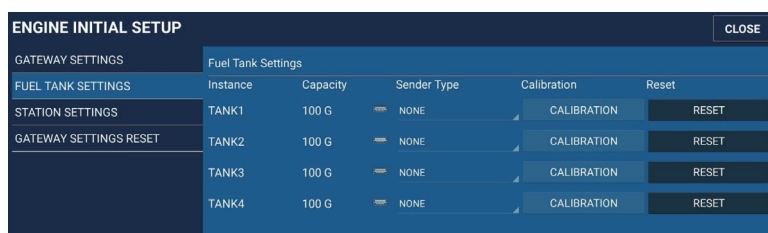

2. Tap the keypad icon to the right of the [Capacity] field for the tank to be set.

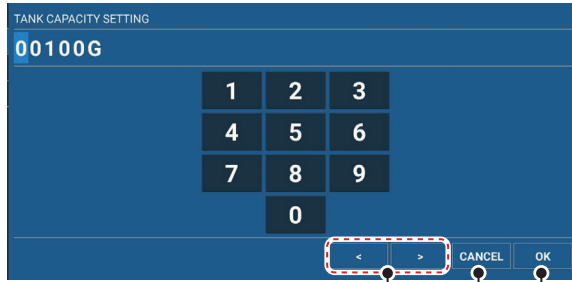

Move the cursor left or right.
 Cancel input and close the keyboard.
 Confirm and apply the value or setting.

3. Input the tank capacity, then tap the [OK] button.
Note: Input 9999L or less.

ABYC & EU & Custom

1. Tap [Sender Type] of the tanks.

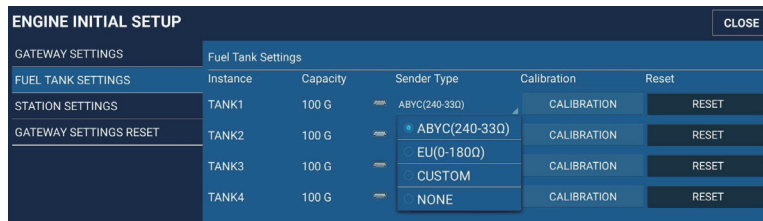

2. Select the sender type.
3. If [CUSTOM] is selected, the [CALIBRATION] button is selectable. Tap the [CALIBRATION] button to show the following message.

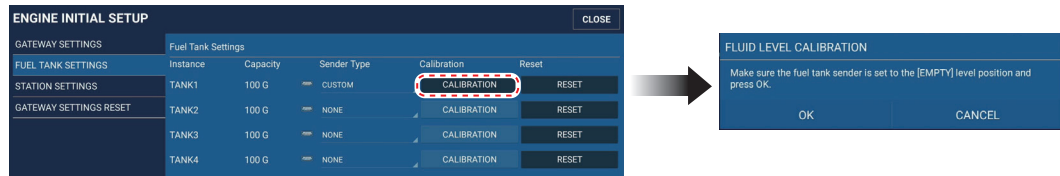

3. HOW TO SET UP THE EQUIPMENT

- Calibrate the fluid level according to the following procedure. Repeat the calibration from EMPTY to FULL.

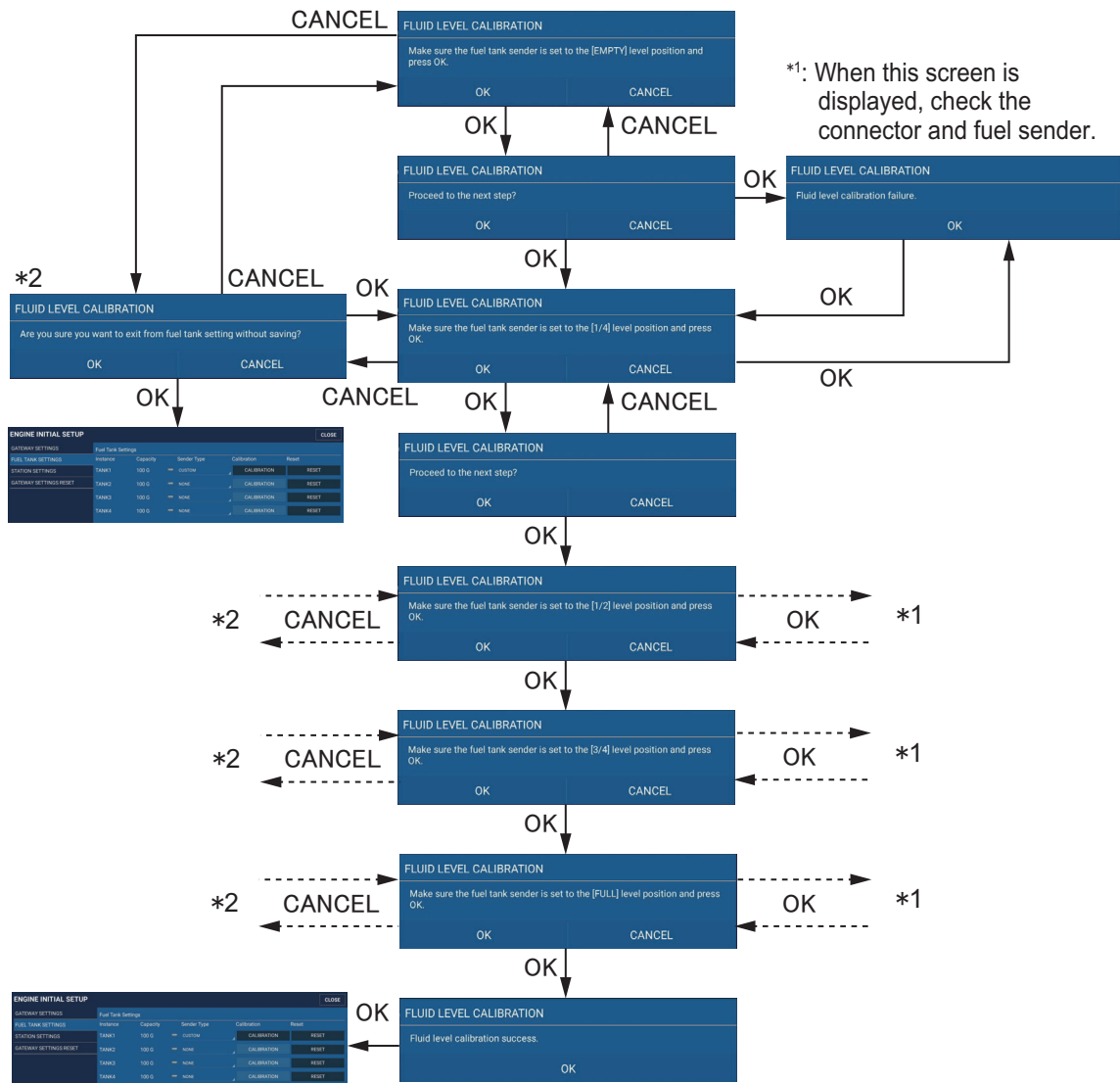

Fuel Tank Settings Reset

You can clear the fuel tank settings and data for any of the connected fuel adapter and their connected engines. Typically this is not required unless you have replaced or added a new engine and/or fuel adapter.

- Tap the [RESET] button of the fuel tank to be initialized.
- If necessary to reset, tap [YES]. If not necessary to reset, tap [CANCEL].
- Initialization completed. Tap the [OK] button and go back to the [Fuel Tank Settings] menu.

APPX. 1 TRANSDUCER INSTALLATION GUIDE

OWNER'S GUIDE & INSTALLATION INSTRUCTIONS

Transom Mount
Side Scan Transducer

Model: **TM904**

Record the information found on the cable tag for future reference.

Part No: _____ Serial No: _____
Date _____ Frequency _____ kHz

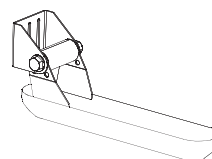

09/28/22

102642-rev.1

D-201960-rev.1

Follow the precautions below for optimal product performance and to reduce the risk of property damage, personal injury, and/or death.

WARNING: Always wear safety glasses, a dust mask, and ear protection when installing.

WARNING: When the boat is placed in the water, immediately check for leaks around the screws and any other holes drilled in the hull.

CAUTION: Never pull, carry, or hold the sensor by the cable as this may sever internal connections.

CAUTION: Never strike the transducer with anything except the palm of the hand. Never strike the paddlewheel.

CAUTION: Never use solvents. Cleaner, fuel, sealant, paint and other products may contain solvents that can damage plastic parts, especially the transducer's face.

IMPORTANT: Please read the instructions completely before proceeding with the installation. These instructions supersede any other instructions in your instrument manual if they differ.

Mounting Location

CAUTION: Do not mount the sensor in line with or near water intake or discharge openings; or behind strakes, struts, fittings, or hull irregularities that will disturb the water flow.

CAUTION: Do not mount the sensor in a location where the boat may be supported during trailering, launching, hauling, or storage.

- For the best performance, the sensor must be in contact with smooth water. To identify an area of "clean" water, observe the water flow off the transom while the boat is underway.
- Mounting the sensor on the side of the transom where the propeller blades are moving downward is preferred (Figure 1).
- Mount the sensor as close to the centerline (keel) of the boat as possible to ensure the transducer's face remains in the water when the boat is turning.

Applications

- Not recommended for boats with inboard engine(s).
- Not recommended for a stepped hull
- Adjusts to *transom* angles from 0°–30°
- Vertically orients sound beam on hull with *deadrise* angle up to 28°
- Recommended for boats capable of speeds up to 30kn (35MPH). Optimal speed is 1.5 - 8.5 kn (2 - 10MPH).

Boat Types

- **Single drive boat**—Mount a minimum of 15cm (6") beyond the swing radius of the propeller (Figure 1).
- **Twin drive boat**—Mount between the drives a minimum of 15cm (6") beyond the swing radius of the propeller.
- **Trim tabs**—Mount inside the trim tab, space permitting.
- **Stepped transom**—Mount the transducer on the lowest step.

Tools & Materials

- Safety glasses
- Dust mask
- Ear protection
- Pencil
- Electric drill
- Drill bits and hole saws:
 - Bracket holes 5 mm, #4, or 7/32"
 - Transom hole (optional) 2 mm or 1/16" larger than connector Ø
 - Cable clamp holes 3 mm or 1/8"
- Masking tape
- Angle finder
- Grommets (some installations)
- Marine sealant (suitable for below waterline)
- Socket wrench
- Torque wrench
- Screwdrivers
- Straight edge
- Cable ties
- Water-based anti-fouling paint (**mandatory in salt water**)

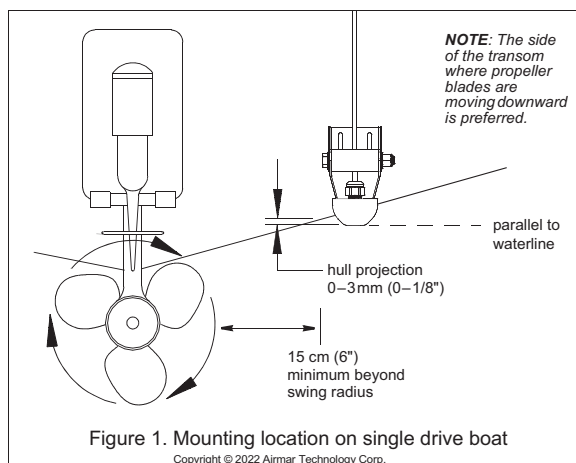

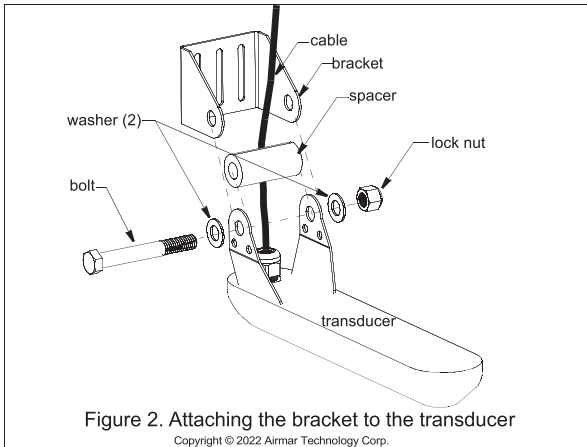

Figure 2. Attaching the bracket to the transducer
Copyright © 2022 Airmar Technology Corp.

Installation

Attaching the Bracket to the Transducer

1. Slide a washer onto the bolt (Figure 2).
2. Align the bracket to the transducer and insert the bolt through the upper hole in the transducer. Slide the spacer onto the bolt and push the bolt through the remaining hole in the transducer and the bracket. Ensure the cable passes between the bracket and the spacer.
3. Slide the remaining washer onto the bolt and hand tighten the lock nut onto the bolt.

Hole Drilling

CAUTION: To prevent drilling too deeply, wrap masking tape around the bit 22mm (7/8") from the point.

NOTE: Fiberglass hull—Minimize surface cracking by running the drill in reverse until the gelcoat is penetrated.

1. At the selected location position the transducer, so it projects 3mm (1/8") below the bottom edge of the transom (Figure 1).
2. Be sure the bottom of the transducer is parallel to the waterline.
3. Mark the screw holes with an "X" in the center of each slot in the bracket.
4. Using a 5mm, #4, or 7/32" drill bit, drill three holes 22mm (7/8") deep at the marked locations.

Mounting the Bracket

CAUTION: Metal hull—The stainless steel bracket must be isolated from a metal hull to prevent electrolytic corrosion. Place non-metal insulating washers between the bracket and the metal hull.

1. Remove the bracket from the transducer.
2. Apply marine sealant to the threads of the three hex-washer-head screws to prevent water seepage into the transom. Screw the bracket to the hull using a socket wrench. *Do not tighten the screws at this time.*
3. Reinstall the transducer to the bracket (Figure 2).

Checking the Sensor Angle & Projection

CAUTION: Do not position the leading edge of the sensor deeper in the water than the trailing edge because aeration will occur.

CAUTION: Do not position the sensor deeper into the water than necessary to avoid increasing drag, spray, and water noise and reducing boat speed.

1. Using the vertical adjustment space in the bracket slots, slide the assembly up or down until the bottom inside corner of the transducer projects 0–3mm (0–1/8") below the bottom of the hull (Figure 1). When you are satisfied with the position of the transducer, tighten the three bracket screws. For clear access to the screws, remove the transducer assembly from the bracket (Figure 2). *When reattaching, be sure to include the spacer.*
2. With the transducer in the operational position, use a straight edge to sight the underside of the transducer relative to the underside of the hull (Figure 3). The trailing edge of the transducer should be 1–6mm (1/16–1/4") below the leading edge. When you are satisfied with the position of the transducer, use a torque wrench to tighten the lock nut to 40ft lbs.

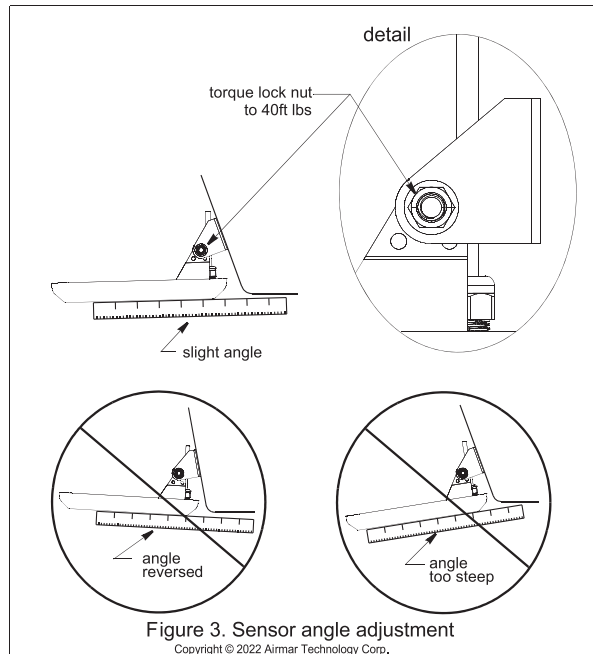

Figure 3. Sensor angle adjustment
Copyright © 2022 Airmar Technology Corp.

Testing on the Water

1. Become familiar with your echosounder's performance at a speed of 4 kn (5MPH).
2. Gradually increase the boat speed and observe the gradual decline in performance due to turbulent water flowing under the transducer's face.
3. If the decline in performance is sudden (not gradual), identify the boat speed at which the onset occurred. Return the boat to this speed, then gradually increase speed while making moderate turns in both directions.
4. If the performance improves while turning to the side on which the sensor is installed, the transducer's position probably needs adjustment. The transducer is probably in turbulent or aerated water.

To improve performance, try the following one at a time in the order given, in small increments.

- a. Increase the sensor's angle in the water. Review "Checking the Sensor Angle & Projection:" and see Figure 3.
- b. Move the sensor deeper into the water in increments of 3mm (1/8") (Figure 4).
- c. Move the sensor closer to the centerline of the boat.
Fill unused screw holes with marine sealant.

NOTE: Optimal operating speed for a side scan transducer is 1.5 - 8.5 kn (2 - 10MPH).

Cable Routing & Connecting

CAUTION: Do not remove the connector to ease cable routing. If the cable must be cut and spliced, use Airmar's splash-proof Junction Box No. 33-035 and follow the instructions provided. Removing the waterproof connector or cutting the cable, except when using a water-tight junction box, will void the sensor warranty.

Route the sensor cable over the transom, through a drain hole, or through a new hole drilled in the transom **above the waterline**.

1. If a hole must be drilled through the transom, choose a location **well above the waterline** (Figure 4). Check for obstructions such as trim tabs, pumps, or wiring inside the hull. Mark the location with a pencil. Drill a hole using the appropriate size bit to accommodate the connector.
2. Route the cable over or through the transom.
3. On the outside of the hull, secure the cable against the transom using the cable clamps. Position a cable clamp 15cm (6") above the bracket and mark the mounting hole with a pencil.
4. Position the second cable clamp halfway between the first clamp and the cable hole. Mark this mounting hole.
5. If a hole has been drilled in the transom, open the appropriate slot in the cable cover. Position the cover over the cable where it enters the hull. Mark the two mounting holes.
6. At each of the marked locations, use a 3mm or 1/8" bit to drill a hole 10mm (3/8") deep.
7. Apply marine sealant to the threads of the #6 x 1/2" self-tapping screws to prevent water from seeping into the transom. If you have drilled a hole through the transom, apply marine sealant to the space around the cable where it passes through the transom.

8. Position the two cable clamps and fasten them in place. If used, push the cable cover over the cable and screw it in place.
9. Route the cable to the instrument being careful not to tear the cable jacket when passing it through the bulkhead(s) and other parts of the boat. Use grommets to prevent chaffing. To reduce electrical interference, separate the sensor cable from other electrical wiring and the engine(s). Coil any excess cable and secure it in place with cable ties to prevent damage.
10. Refer to your echosounder owner's manual to connect the sensor to the instrument.

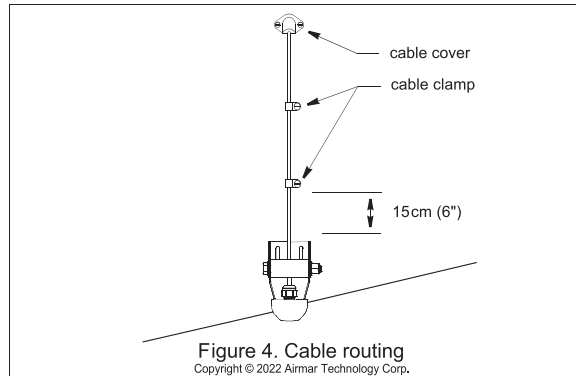

Checking for Leaks

When the boat is placed in the water, **immediately** check for leaks around the screws and any other holes drilled in the hull. Note that very small leaks may not be readily observed. Do not leave the boat in the water unchecked for more than three hours.

Operation & Maintenance

Anti-fouling Paint

Surfaces exposed to salt water that *do not interlock*, must be coated with anti-fouling paint. Use **water-based** anti-fouling paint only. Never use ketone-based paint, since ketones can attack many types of plastic possibly causing damage to the transducer. Reapply paint every 6 months or at the beginning of each boating season.

Cleaning

Aquatic growth can accumulate rapidly on the sensor's surface reducing performance within weeks. Clean the transducer's face with a Scotch-Brite® scour pad and mild household detergent taking care to avoid making scratches. If the fouling is severe, lightly wet sand with fine grade wet/dry paper.

Sensor Replacement & Parts

The information needed to order a replacement sensor is printed on the cable tag. Do not remove this tag. When ordering, specify the part number, serial number, date, and frequency in kHz. For convenient reference, record this information on the top of page one.

Lost, broken or worn parts should be replaced immediately. Obtain parts from your instrument manufacturer or marine dealer.

Gemeco

USA

Tel: 803-693-0777
email: sales@gemeco.com

Airmar EMEA

Europe, Middle East, Africa

Tel: +33.(0)2.23.52.06.48
email: sales@airmar-emea.com



35 Meadowbrook Drive, Milford, New Hampshire 03055-4613, USA
•www.airmar.com

Copyright © 2022 Airmar Technology Corp. All rights reserved.



OWNER'S GUIDE & INSTALLATION INSTRUCTIONS

Sidescan Transducer with Anti-rotation Hardware

Model: **SS904**

Record the information found on the cable tag for future reference.

Part No: _____ Serial No: _____
Date _____ Frequency _____ kHz

05/24/22
102366-rev.1
D-20553-rev.1

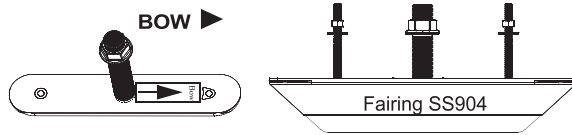

Follow the precautions below for optimal product performance and to reduce the risk of property damage, personal injury, and/or death.

WARNING: Installation of the anti-rotation studs/screws is mandatory! The anti-rotation studs/screws hold the fairing firmly in place. Failure to install the anti-rotation studs/screws may result in the fairing rotating while the boat is underway. The effect may be violent movement and loss of steering.

WARNING: The transducer must be installed parallel to the keel/centerline to ensure proper boat handling and water flow under the transducer.

WARNING: Always wear safety glasses, a dust mask, and ear protection when installing.

WARNING: Immediately check for leaks when the boat is placed in the water. Do not leave the boat in the water unchecked for more than three hours. Even a small leak may allow a considerable amount of water to accumulate.

WARNING: Fairing—The fairing must be screwed to a block of wood before cutting. It is too thin to cut safely without additional material. Failure to do so may result in the fairing moving on the band saw.

WARNING: Fairing—Do not install a fairing that has been mis-cut. Replace it.

- Cutting the fairing at an angle greater than the maximum allowed will cut into the transducer and/or anti-rotation pockets, thus weakening the fairing.
- Do not allow any gap between the fairing and the hull that is greater than 1.5mm (1/16"). When the boat is underway, water will enter any gaps and push against the fairing with considerable force, possibly rotating it.

WARNING: Fiberglass hull—The transducer must be installed in solid fiberglass, not in coring.

CAUTION: Never install a metal transducer on a vessel with a positive ground system.

CAUTION: Never pull, carry, or hold the transducer by the cable as this may sever internal connections.

CAUTION: Never strike the transducer.

CAUTION: Stainless steel transducer in a metal hull—Stainless steel must be isolated from a metal hull to prevent electrolytic corrosion. Use the isolation sleeving supplied.

CAUTION: Transducer Orientation—Be sure to install the transducer in the correct orientation to the bow. If the transducer is installed in reverse, the display will not work properly.

CAUTION: Installation without a Fairing—The transducer must be installed on a nearly flat hull with less than 10° of deadrise. Do not install on a V-hull. If the transducer is installed without a fairing on a hull with a deadrise greater than 10°, the display will not work properly.

CAUTION: Transducer Pair—Be sure to install the port transducer and the starboard transducer in the correct orientation to the bow. If the transducers are installed in reverse, the display will not work properly.

CAUTION: Never use solvents. Cleaner, fuel, sealant, paint, and other products may contain solvents that can damage plastic parts, especially the transducer's face.

IMPORTANT: Read the instructions completely before proceeding with the installation. These instructions supersede any other instructions in your instrument manual if they differ.

Applications

- Stainless steel is compatible with all hull materials. Recommended for aluminum hulls to prevent electrolytic corrosion, provided the stainless steel transducer is isolated from the metal hull.
- Recommended for boats capable of speeds up to 30kn (35MPH). Optimal speed is 1.5 - 8.5 kn (2 - 10MPH).
- A fairing is strongly recommended if the deadrise angle of the hull exceeds 10°. The fairing can accommodate a deadrise angle of up to 22°.
- **Transducer Pair** - On a boat with a steep deadrise angle, a pair of transducers, one on the port side and one on the starboard side, can be installed and connected to the echosounder module.
- For stepped hulls, to be installed just ahead of the first step.

Tools & Materials

- Safety glasses
- Dust mask
- Ear protection
- Angle finder (installation with fairing)
- Band saw (installation with fairing)
- Block of wood (installation with fairing) min. 4" x 4" x 18"
- Screws (4) (installation with fairing) No. 8
- Screwdrivers
- Rasp or power tool (installation with fairing)
- Electric drill
- Drill bits and hole saws:
 - Pilot hole 3mm or 1/8"
 - Transducer stem 25mm or 1"
 - Anti-rotation studs in solid fiberglass or wood hull 9mm or 11/32"
 - Anti-rotation studs in metal hull 10mm or 3/8"
- Sandpaper
- Mild household detergent or weak solvent (such as alcohol)
- File (installation in metal hull)
- Marine sealant (suitable for below waterline)
- Slip-joint pliers
- Grommet(s) (some installations)
- Cable ties
- Water-based anti-fouling paint (**mandatory in salt water**)
- Installation in a cored fiberglass hull: (see page 8)
 - Drill bits and hole saws for hull interior:
 - Transducer stem 38mm or 1-1/2"
 - Anti-rotation studs 19mm or 3/4"
 - Cylinder, wax, tape, and casting epoxy

Mounting Location

Guidelines

CAUTION: Do not mount in line with or near water intake or discharge openings or behind strakes, struts, fittings, or hull irregularities that will disturb the water flow.

CAUTION: Do not mount the sensor where the boat may be supported during trailering, launching, hauling, or storage to avoid damaging the transducer's face.

- The water flowing under the hull must be smooth with a minimum of bubbles and turbulence (especially at high speeds).
- The transducer must be continuously immersed in water.
- The transducer beam must be unobstructed by the keel or propeller shaft(s).
- Choose a location away from interference caused by power and radiation sources such as: the propeller(s) and shaft(s), other machinery, other echosounders, and other cables. The lower the noise level, the higher the echosounder gain setting that can be used.
- Choose an accessible spot inside the vessel with adequate space for the height of the stem and tightening the nuts.
- Choose a location with a minimal deadrise angle. If the hull has a steep deadrise, mount a pair of transducers.

Boat Types (Figure 1)

- **Planing hull powerboat**—Mount well aft near the centerline and well inboard of the first set of lifting strakes to insure that it is in contact with the water at high speeds. The starboard side of the hull where the propeller blades are moving downward is preferred.
- **Outboard and I/O**—Mount just forward and to the side of the engine(s).
- **Inboard**—Mount well ahead of the propeller(s) and shaft(s).
- **Stepped hull**—Mount just ahead of the first step.
- **Displacement hull powerboat**—Locate 1/3 of the way along the LWL and 150–300mm (6–12") off the centerline. The starboard side of the hull where the propeller blades are moving downward is preferred.
- **Transducer Pair**—Mount the transducers across from one another on opposite sides of the centerline (keel).

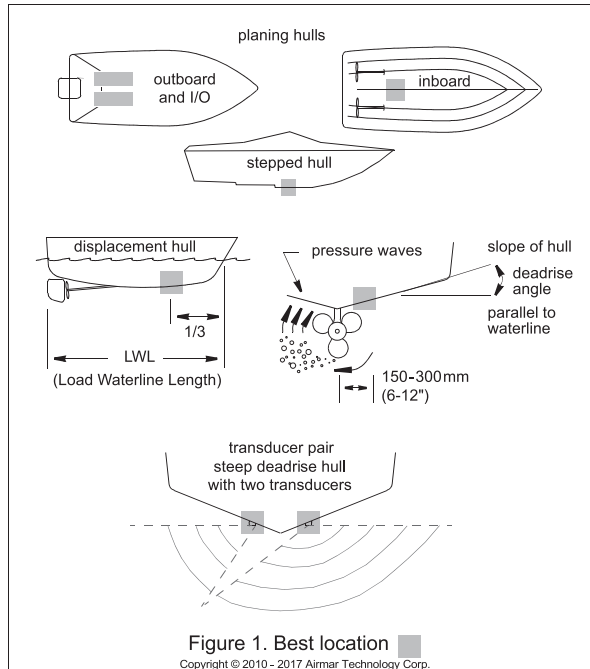

Figure 1. Best location
Copyright © 2010 - 2017 Airmar Technology Corp.

APPX. 1 TRANSDUCER INSTALLATION GUIDE

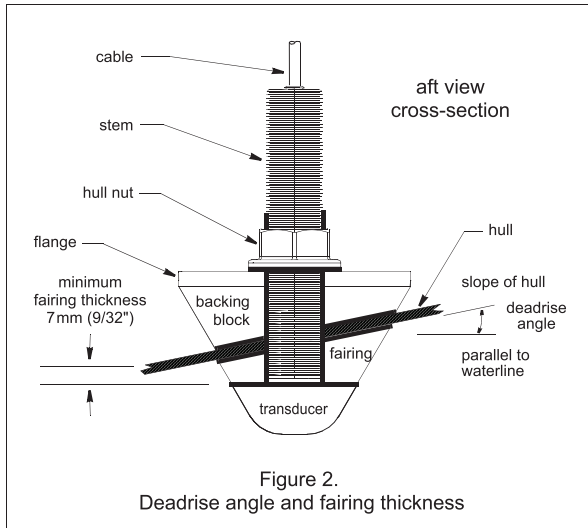

Figure 2.
Deadrise angle and fairing thickness

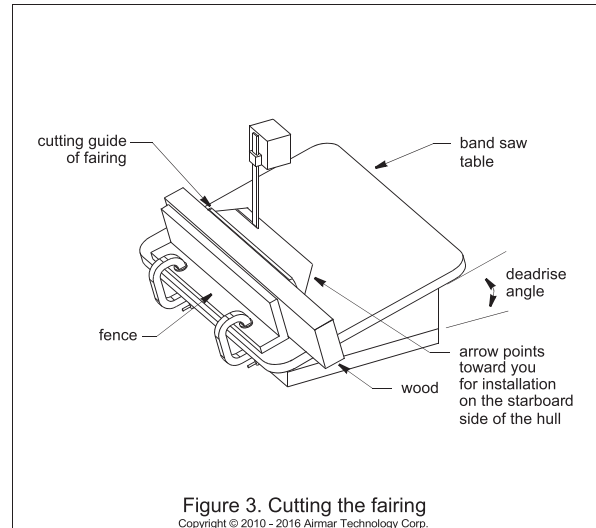

Figure 3. Cutting the fairing
Copyright © 2010 - 2016 Almar Technology Corp.

Installation:

NOTE: If you are installing the transducer with NO fairing, disregard all references to a fairing and backing block. Skip to "Hole Drilling" on page 3.

Cutting the Fairing

CAUTION: The arrow on the fairing points forward toward the bow when installed. Be sure to orient the fairing on the band saw, so the angle cut matches the intended side of the hull and not the mirror image.

CAUTION: Shape the fairing to the hull as precisely as possible. If there are gaps between the fairing and the hull near the ends, cut a new fairing. Over tightening the rods to minimize gaps may crack the transducer and/or crush the fairing.

- 1. Metal hull**—The holes for the anti-rotation studs must be enlarged to accommodate the isolation sleeving. Using a 10mm (3/8") drill bit, enlarge the two holes in the fairing.
- Measure the deadrise angle of the hull at the selected mounting location using an angle finder or a digital level (Figure 3).
- Tilt the band saw table to the measured angle and secure the cutting fence (Figure 4).
- Fasten the fairing to the center of the block of wood using the four corner holes and No. 8 screws.
- Place the fairing on the table so the cutting guide rests against the fence. The arrow will be pointing *toward* you for installation on the starboard side of the boat or *away* from you for installation on the port side (Figure 5).
- Adjust the cutting fence, so the fairing will be cut in about two equal parts (Figure 3). *The section that will become the fairing must be a minimum of 7mm (9/32") at its thinnest dimension.* This number corresponds to the flange on the fairing.
- Recheck steps 1 through 5. Then cut the fairing.
- Check the fit of the fairing by placing it against the hull, being sure it is parallel to the centerline of the boat (keel).** Hold the fairing on the ends and try to rock it back and forth. Shape the fairing to the hull as precisely as possible with a rasp or power tool until it no longer rocks.

- Remove the fairing from the block of wood.
- Use the remaining section of the fairing with the cutting guide as the backing block.

Hole Drilling

Cored fiberglass hull—Follow separate instructions on page 6.

- Locate and drill the holes for the transducer stem and anti-rotation studs, using the fairing or the provided template on page 8 as a guide (Figure 4, 5, 6, or 7). Align the fairing or template parallel to the centerline of the boat (keel).
 - Drill 3mm (1/8") pilot holes for the transducer stem and the two anti-rotation studs.
 - Using the appropriate drill bits/hole saw, drill the holes for the transducer stem and the two anti-rotation studs.

Fairing—Drill through the holes in the fairing to be sure the holes are drilled *perpendicular to the waterline* and not at the angle of the hull.

NO Fairing—Be sure to drill the holes perpendicular to the hull.
- Sand and clean the area around the holes, inside and outside, to ensure the marine sealant will adhere properly to the hull. If there is any petroleum residue inside the hull, remove it with either a mild household detergent or a weak solvent (alcohol) before sanding.

Metal hull—Remove all burrs with a file and sandpaper.

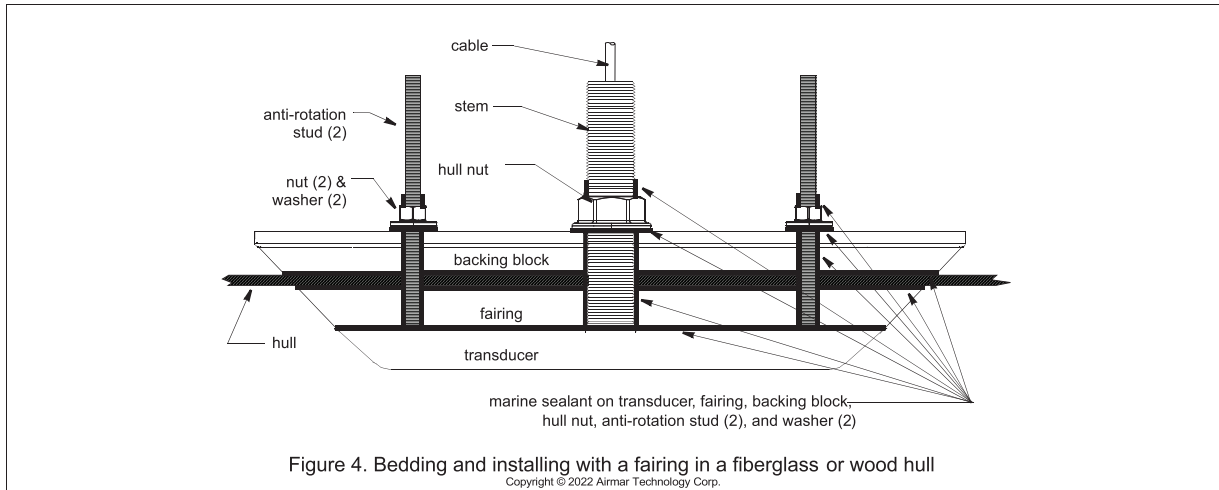

Bedding

CAUTION: Be sure all surfaces to be bedded are clean and dry.

CAUTION: When installing the anti-rotation studs, use slip-joint pliers placed near the bottom of the stud. Do not use pliers farther up, as this will damage the threads.

1. Remove the hull nut (Figure 4, 5, 6, or 7).
2. Apply a 2mm (1/16") thick layer of marine sealant to the surface of the transducer that will contact the hull/fairing and up the stem. *The sealant must extend 6mm (1/4") higher than the combined thickness of the hull, fairing and backing block (if used), and the hull nut.* This will ensure there is marine sealant in the threads to seal the hull and hold the hull nut securely in place.
3. Apply a 2mm (1/16") thick layer of marine sealant around the anti-rotation studs *including the bottom.* This will ensure there is marine sealant in the threads to secure the studs in the transducer, seal the hull, and hold the nut securely in place.
4. Screw the anti-rotation studs into the holes in the transducer. Using slip-joint pliers placed *near the bottom of the stud*, tighten

each one in turn. Do not use pliers farther up, as this will damage the threads.

5. Metal hull—Use the isolation sleeving to cover the transducer stem and the two anti-rotation studs. Cut the length of each sleeve greater than the thickness of the hull. *Note that the sleeves must not interfere with tightening the nuts.* Slide the larger diameter isolation sleeve over the bedded transducer stem. Slide the two remaining isolation sleeves over the bedded anti-rotation studs. Slide the sleeves as far down as possible. Apply a 2mm (1/16") thick layer of the marine sealant to the outside of the three isolation sleeves.

6. Fairing—Thread the transducer cable through the fairing. Seat the transducer firmly within the recess in the fairing. Apply a 2mm (1/16") thick layer of marine sealant to the following surfaces:

- Fairing that will contact the hull
- Backing block that will contact the hull
- Hull nut that will contact the backing block
- Washers for the anti-rotation studs that will contact the backing block

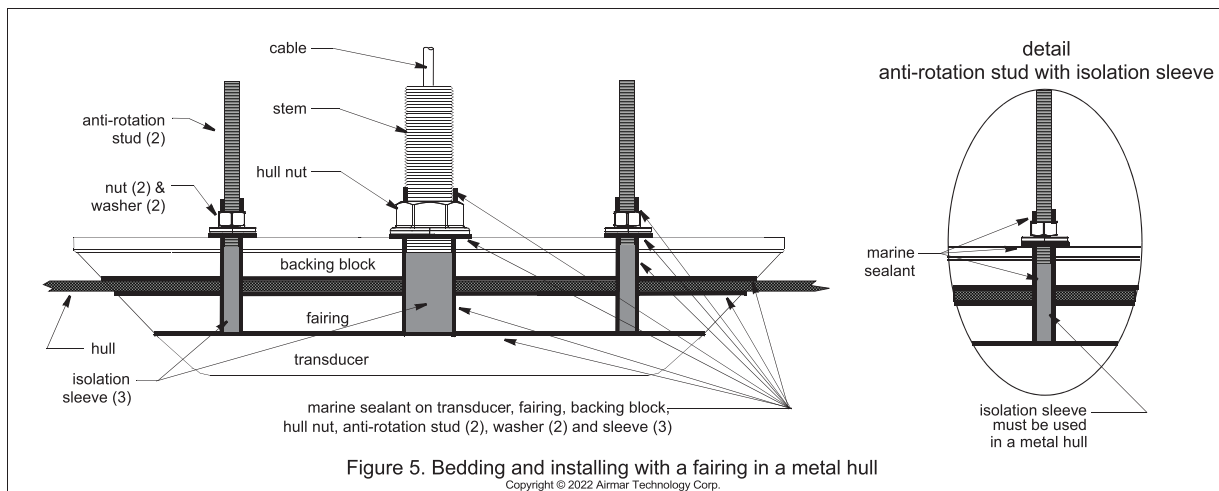

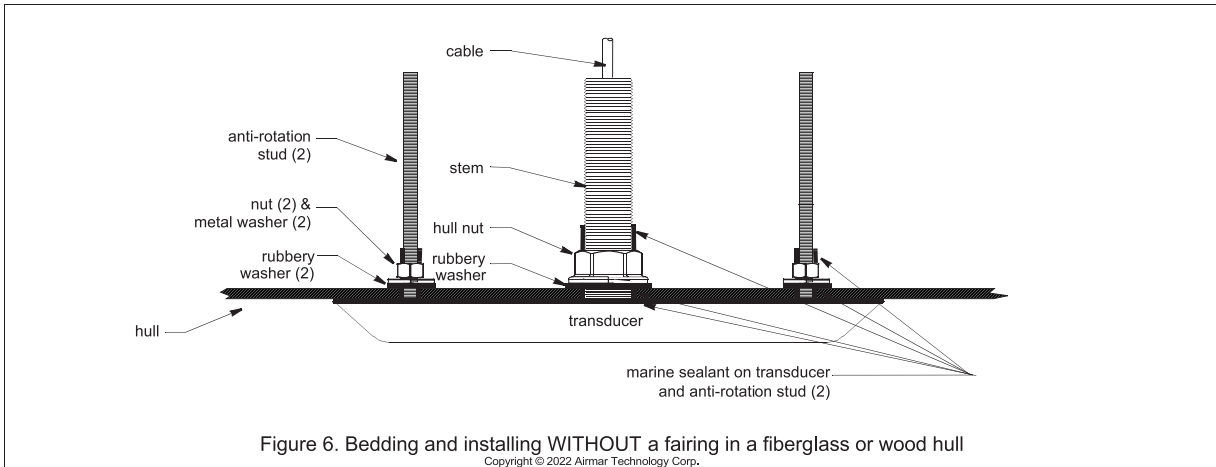

Installing

CAUTION: Do not over-tighten the nuts possibly damaging the transducer or fairing.

1. From outside the hull, thread the cable through the mounting hole (Figure 4, 5, 6, or 7).
2. Push the stem of the transducer and the anti-rotation studs through the hull.
3. From inside the hull:

- **Fairing**—Slide the backing block and the hull nut onto the cable. Seat the backing block firmly against the hull. Screw the hull nut in place and tighten it with slip-joint pliers. *Do not over-tighten.* With the bedded side down, slide one washer and nut onto each anti-rotation stud. Tighten the nuts *one full turn only* with slip-joint pliers. *Do not over-tighten.*
- **Cored fiberglass hull**—*Do not over-tighten* crushing the hull.
- **Wood hull**—Allow for the wood to swell before tightening.
- **Metal hull**—Be sure the isolation sleeves are between the transducer stem/studs and the hull. *The isolation sleeves must be below the nuts to prevent the sleeves from interfering with tightening the nuts.* Trim the sleeves if necessary.

- **NO fairing**—Slide the rubbery washer and hull nut onto the cable. Seat the rubbery washer firmly against the hull. Screw the hull nut in place and tighten it with slip-joint pliers. *Do not over-tighten.* Slide the rubbery washer, metal washer, and nut onto each anti-rotation stud. Seat the rubbery washer firmly against the hull. Tighten the nuts *one full turn only* with slip-joint pliers. *Do not over-tighten.*
 - **Cored fiberglass hull**—*Do not over-tighten* crushing the hull.
 - **Wood hull**—Allow for the wood to swell before tightening.
 - **Metal hull**—Be sure the isolation sleeves are between the transducer stem/studs and the hull. *The isolation sleeves must be below the nuts to prevent the sleeves from interfering with tightening the nuts.* Trim the sleeves if necessary.
4. **Fairing**—When the boat is underway, especially at high speeds, water will enter any gaps and push against the fairing with considerable force, possibly rotating it. Fill any gaps between the fairing and the hull with marine sealant. **If there is any gap greater than 1.5 mm (1/16"), replace the fairing.**
 5. Remove any excess marine sealant on the outside of the hull, transducer, and fairing if used to ensure smooth water flow under the transducer.

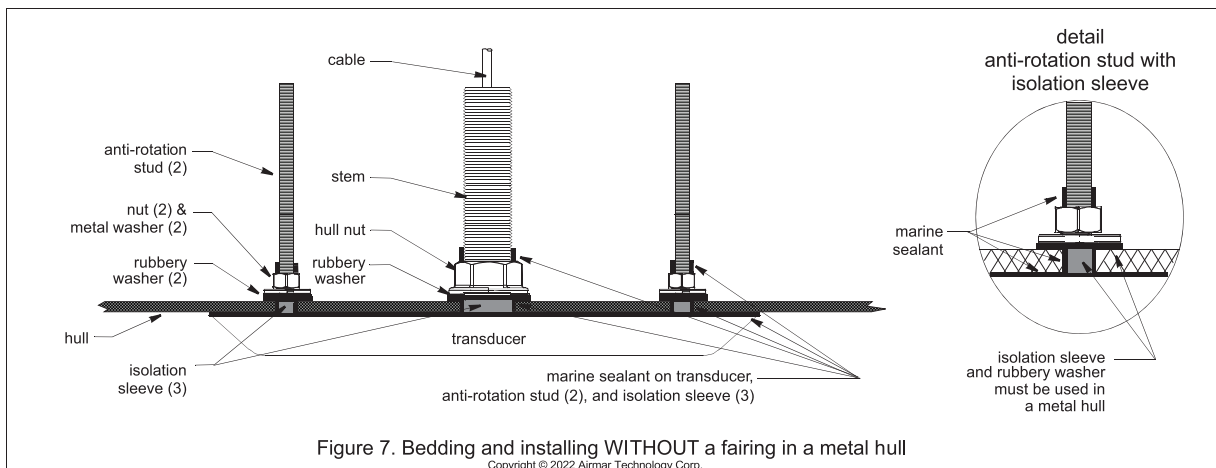

Installation in a Cored Fiberglass Hull

The core (wood or foam) must be cut and sealed carefully. The core must be protected from water seepage, and the hull must be reinforced to prevent it from crushing under the hull nut allowing the transducer(s) to become loose.

CAUTION: Completely seal the hull to prevent water seepage into the core.

1. Drill a 3 mm or 1/8" pilot hole perpendicular to the waterline from inside the hull (Figure 8). If there is a rib, strut, or other hull irregularity near the selected mounting location, drill from the outside. If the hole is drilled in the wrong location, drill a second hole in a better location. Apply masking tape to the outside of the hull over the incorrect hole and fill it with epoxy.
2. Using the appropriate size drill bit/hole saw, cut a hole from outside the hull through the outer skin only. Be sure to hold the drill plumb, so the hole will be perpendicular to the water surface.
3. The optimal interior hole diameter is affected by the hull's thickness and deadrise angle. It must be large enough in diameter to allow the core to be completely sealed.
4. Using the drill bit/hole saw for the hull interior, cut through the *inner* skin and most of the core from inside the hull keeping the drill perpendicular to the hull. The core material can be very soft. Apply only light pressure to the drill bit after cutting through the *inner* skin to avoid accidentally cutting the *outer* skin.
5. Remove the plug of core material so the *inside* of the outer skin and the inner core of the hull is fully exposed. Sand and clean the inner skin, core, and the outer skin around the hole.
6. Coat a hollow or solid cylinder of the correct diameter with wax and tape it in place. Fill the gap between the cylinder and hull with casting epoxy. After the epoxy has set, remove the cylinder.
7. Sand and clean the area around the hole, inside and outside, to ensure that the sealant will adhere properly to the hull. If there is any petroleum residue inside the hull, remove it with either mild household detergent or a weak solvent (alcohol) before sanding.
8. Follow the same procedure to prepare the hull for each anti-rotation stud/screw (steps 1 through 6).
9. Proceed with "Bedding" on page 4.

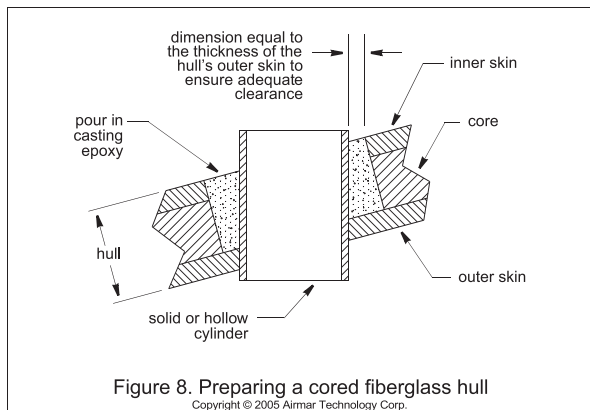

Cable Routing & Connecting

CAUTION: Do not remove the connector(s) to ease cable routing. If a cable must be cut and spliced, use Airmar's splash-proof Junction Box No. 33-035 and follow the instructions provided. Removing the waterproof connector or cutting the cable, except when using a water-tight junction box, will void the sensor warranty.

1. Refer to the instructions that came with the echo sounder module to connect it to the display and the power supply.
2. **Transducer Pair**—Connect the starboard transducer to the short cable on the port transducer. Rout the longer cable on the port transducer to the echo sounder module (Figure 9).

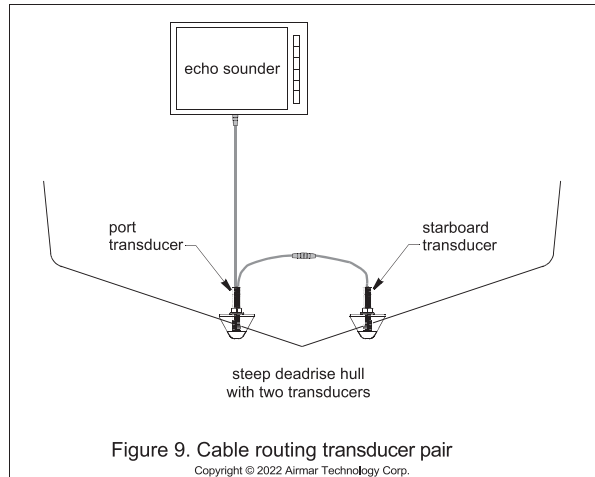

Maintenance, Parts & Replacement

Anti-fouling Coating

Surfaces exposed to salt water must be covered with an anti-fouling coating. Use a *water-based* anti-fouling coating made for transducers only. Never use ketone based paint, since ketones can attack many plastics possibly damaging the transducer. Brush on anti-fouling coating every 6 months or at the beginning of each boating season.

Checking for Leaks

When the boat is placed in the water, **immediately** check around the transducer(s) for leaks. Note that very small leaks may not be readily observed. Do not leave the boat in the water for more than 3 hours before checking it again. If there is a small leak, there may be considerable bilge water accumulation after 24 hours. If a leak is observed, repeat "Bedding" and "Installing" **immediately**.

Cleaning

Aquatic growth can accumulate rapidly on the transducer's surface reducing its performance within weeks. Clean the surface with a Scotch-Brite® scour pad and mild household detergent taking care to avoid making scratches. If the fouling is severe, lightly wet sand with fine grade wet/dry paper.

APPX. 1 TRANSDUCER INSTALLATION GUIDE

Transducer Replacement & Parts

The information needed to order a replacement transducer is printed on the cable tag. Do not remove this tag. When ordering, specify the part number, serial number, date, and frequency in kHz. For convenient reference, record this information on the top of page 1.

Lost, broken, and worn parts should be replaced immediately.

Obtain parts from your instrument manufacturer or marine dealer.

Model	Fairing	Hull Nut
SS904	ACC-FAIR-SS904-01	02-149-01

Gemeco

USA

Tel: 803-693-0777
Email: sales@gemeco.com

Airmar EMEA

Europe, Middle East, Africa

Tel: +33.(0)2.23.52.06.48
Email: sales@airmar-emea.com



35 Meadowbrook Drive, Milford, New Hampshire 03055-4613, USA
• www.airmar.com

Copyright © 2012 - 2018 Airmar Technology Corp. All rights reserved.

Template
SS904

IMPORTANT: Some printers and printer settings can alter the size of the template.

Verify the template's size before cutting. Place the transducer on the template to be sure it is the *exact* size. If necessary, redraw the template.

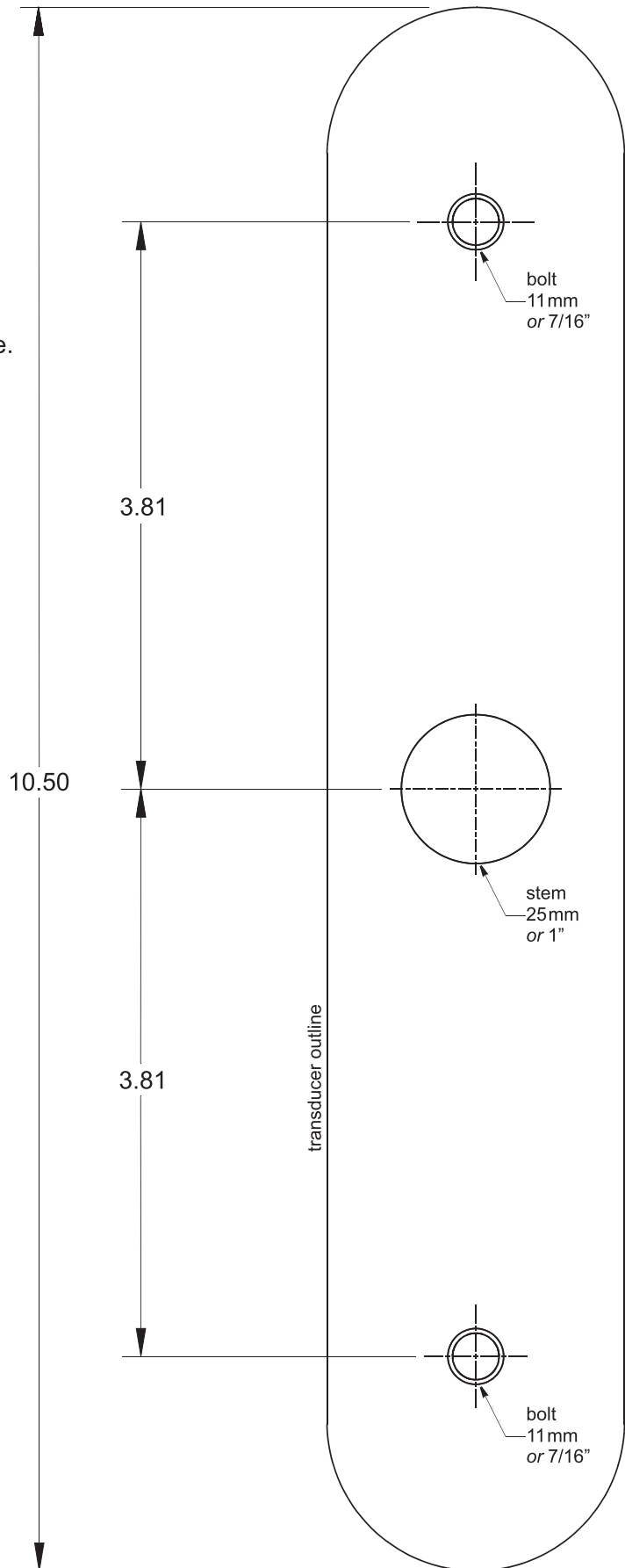

APPX. 2 INSTALLATION OF TEMPERATURE SENSORS

OWNER'S GUIDE &

Thru-Hull, Analog
High-Precision Temperature Sensor

Model T42

04/06/20
T7-437-02 rev. 03

Follow the precautions below for optimal product performance and to reduce the risk of property damage, personal injury, and/or death.

WARNING: Always wear safety goggles and a dust mask when installing.

WARNING: Immediately check for leaks when the boat is placed in the water. Do not leave the boat unchecked for more than three hours. Even a small leak can allow considerable water to accumulate.

CAUTION: Never install a bronze sensor in a metal hull because electrolytic corrosion will occur.

CAUTION: Never install a metal sensor on a vessel with a positive ground system.

CAUTION: Never pull, carry, or hold the sensor by its cable; this may sever internal connections.

CAUTION: Never use solvents. Cleaner, fuel, sealant, paint, and other products may contain solvents that can damage plastic parts, especially the sensor's face.

IMPORTANT: Read the instructions completely before proceeding with the installation. These instructions supersede any other instructions in your instrument manual if they differ.

Applications

- Bronze sensor recommended for fiberglass or wood hull only.
- The hull must be a minimum of 8mm (5/16") thick at the mounting location.

Mounting Location

Choose a location where the temperature sensor will be in contact with the water at all times.

INSTALLATION INSTRUCTIONS

Record the information found on the cable tag for future reference.

Part No. _____ Date _____

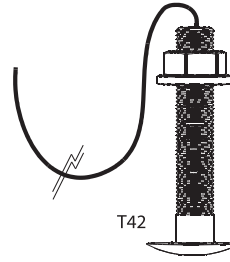

Tools & Materials

- Safety goggles
- Dust mask
- Electric drill
- Drill bit/hole saw/spade bit:
 - Pilot hole 3 mm or 1/8"
 - T42 22 mm or 7/8"
- Sandpaper
- Mild household detergent or weak solvent (alcohol)
- Marine sealant (suitable for below waterline)
- Slip-joint pliers
- Installation in a cored fiberglass hull (see page 2)
 - Hole saw for hull interior: 30mm or 1-1/4"
 - Cylinder, wax, tape, and casting epoxy
- Water-based anti-fouling paint (**mandatory in salt water**)

Sensor Installation

Hole Drilling

Cored fiberglass hull—Follow separate instructions on page 2.

1. Drill a 3 mm or 1/8" pilot hole from inside the hull. If there is a rib, strut, or other hull irregularity near the selected mounting location, drill from the outside.
2. Using the appropriate drill bit, cut a hole perpendicular to the hull from outside the boat.
3. Sand and clean the area around the hole, inside and outside, to ensure that the marine sealant will adhere properly to the hull. If there is any petroleum residue inside the hull, remove it with either mild household detergent or a weak solvent (alcohol) before sanding.

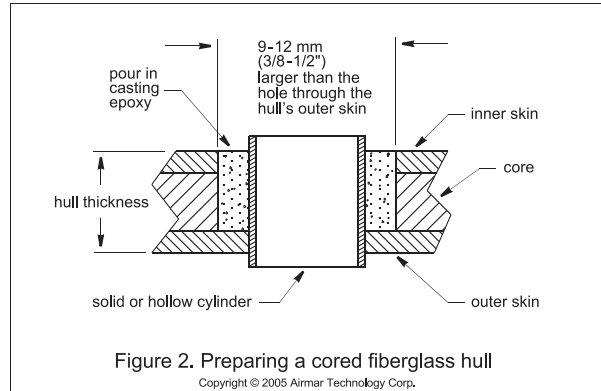
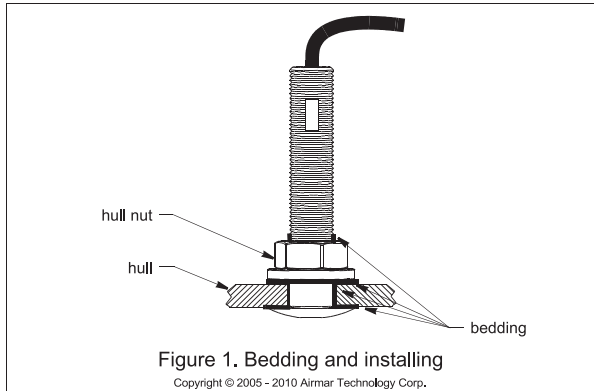

Bedding

CAUTION: Be sure all surfaces to be bedded are clean and dry.

1. Remove the hull nut (see Figure 1).
2. Apply a 2 mm (1/16") thick layer of marine sealant around the flange of the sensor that will contact the hull and up the stem. The sealant must extend 6mm (1/4") higher than the combined thickness of the hull and the hull nut. This will ensure that there is marine sealant in the threads to seal the hull and hold the hull nut securely in place.
3. Apply a 2 mm (1/16") thick layer of marine sealant to the flange of the hull nut that will contact the hull.

Installing

1. From outside the hull, thread the cable through the mounting hole.
2. Push the sensor into the mounting hole using a twisting motion to squeeze out excess marine sealant (see Figure 1).
3. From inside the hull, slide the hull nut onto the cable. Screw the hull nut in place. Tighten it with slip-joint pliers.
Cored fiberglass hull—Do not over tighten, crushing the hull.
Wood hull—Allow for the wood to swell before tightening.
4. Remove any excess marine sealant on the outside of the hull to ensure smooth water flow over the sensor.

Checking for Leaks

When the boat is placed in the water, **immediately** check around the thru-hull sensor for leaks. Note that very small leaks may not be readily observed. Do not leave the boat in the water for more than 3 hours before checking it again. If there is a small leak, there may be considerable bilge water accumulation after 24 hours. If a leak is observed, repeat "Bedding" and "Installing" **immediately** (see page 2).

Cable Routing & Connecting

CAUTION: If the sensor came with a connector, do not remove it to ease cable routing. If the cable must be cut and spliced, use Airmar's splash-proof Junction Box No. 33-035 and follow the instructions supplied. Removing the waterproof connector or cutting the cable, except when using a water-tight junction box, will void the sensor warranty.

1. Route the cable to the instrument being careful not to tear the cable jacket when passing it through the bulkhead(s) and other parts of the boat. Use grommet(s) to prevent chafing. To reduce electrical interference, separate the transducer cable from other electrical wiring and the engine. Coil any excess cable and secure it in place with cable ties to prevent damage.
2. Refer to the instrument owner's manual to connect the transducer to the instrument.

Installation in a Cored Fiberglass Hull

The core (wood or foam) must be cut and sealed carefully. The core must be protected from water seepage, and the hull must be reinforced to prevent it from crushing under the hull nut allowing the sensor to become loose.

CAUTION: Completely seal the hull to prevent water seepage into the core.

1. Drill a 3mm or 1/8" pilot hole from inside the hull. If there is a rib, strut, or other hull irregularity near the selected mounting location, drill from the outside. (If the hole is drilled in the wrong location, drill a second hole in a better location. Apply masking tape to the outside of the hull over the incorrect hole and fill it with epoxy.)
2. Using the 21mm or 7/8" drill bit, cut a hole from outside the hull through the *outer* skin only (see Figure 2).
3. From inside the hull using the 30mm or 1-1/4" hole saw, cut through the *inner* skin and most of the core. The core material can be very soft. Apply only light pressure to the hole saw after cutting through the inner skin to avoid accidentally cutting the *outer* skin.
4. Remove the plug of core material so the *inside* of the outer skin and the inner core of the hull is fully exposed. Clean and sand the inner skin, core, and the outer skin around the hole.
5. Coat a hollow or solid cylinder of the correct diameter with wax and tape it in place. Fill the gap between the cylinder and hull with casting epoxy. After the epoxy has set, remove the cylinder.
6. Sand and clean the area around the hole, inside and outside, to ensure that the sealant will adhere properly to the hull. If there is any petroleum residue inside the hull, remove it with either mild household detergent or a weak solvent (alcohol) before sanding.
7. Proceed with "Bedding" and "Installing" (see page 2).

APPX. 2 INSTALLATION OF TEMPERATURE SENSORS

Maintenance & Replacement

Aquatic growth can accumulate rapidly on the sensor's surface reducing its performance within weeks. Clean the surface with a Scotch-Brite® scour pad and mild household detergent taking care to avoid making scratches. If the fouling is severe, lightly wet sand with fine grade wet/dry paper.

Anti-fouling Paint

Surfaces exposed to salt water must be coated with anti-fouling paint. **Use water-based anti-fouling paint only.** Never use ketone-based paint since ketones can attack many plastics possibly damaging the sensor. Reapply anti-fouling paint every 6 months or at the beginning of each boating season.

Replacement Sensor & Parts

The information needed to order a replacement sensor is printed on the cable tag. Do not remove this tag. When ordering, specify the part number and date. For convenient reference, record this information at the top of page one.

Lost, broken, or worn parts should be replaced immediately.

Hull nut 02-031-3

Obtain parts from your instrument manufacturer or marine dealer.

Gemeco Tel: 803-693-0777
(US A) Fax: 803-693-0477
email: sales@gemeco.com

Airmar EMEA Tel: +3 3.(0)2.23.52.06.48
(Europe, Middle East, Africa) Fax: +33.(0)2.23.52.06.49
email: sales@airmar-emea.com



35 Meadowbrook Drive, Milford, New Hampshire 03055-4613, USA
•www.airmar.com

Copyright © 2014 Airmar Technology Corp. All rights reserved.

OWNER'S GUIDE & INSTALLATION INSTRUCTIONS

Surface Mount: Analog

Temperature Sensor

Model: T80

Patent <http://www.airmar.com/patent.html>

07/24/18

17-584-01 rev. 02

Follow the precautions below for optimal product performance and to reduce the risk of property damage, personal injury, and/or death.

WARNING : Always wear safety glasses, a dust mask, and ear protection when installing.

WARNING : Below the waterline mount —When the boat is placed in the water, immediately check for leaks around the screws and any other holes drilled in the hull.

CAUTION : Installation on a metal hull —The stainless steel housing must be isolated from a metal hull to prevent electrolytic corrosion. Use marine sealant.

CAUTION : Never install a metal sensor on a vessel with a positive ground system.

IMPORTANT : Read the instructions completely before proceeding with the installation. These instructions supersede any other instructions in your instrument manual if they differ.

Tools & Materials

Safety glasses

Dust mask

Ear protection

Pencil

Electric drill

Drill bit/hole saw/spade bit:

Pilot holes 3 mm or 1/8"

Transom hole (some installations) 18mm or 3/4"

2 Stainless steel, self-tapping screws 4 x 18mm or #8 x 3/4"

Marine sealant (suitable for below waterline)

Screwdriver(s)

Cable clamp(s) (some installations)

Grommet(s) (some installations)

Cable ties

Record the information found on the cable tag for future reference.

Part No. _____ Date _____



Applications

- Measures air or water temperature.
- Stainless steel sensor is compatible with all hull materials. Recommended for aluminum hulls to prevent electrolytic corrosion, provided the stainless steel sensor is isolated from the metal hull by using marine sealant.

Mounting Location

The sensor can be mounted anywhere that you want to know the temperature. For example, you can mount the sensor on the transom, in the live well, or in the engine compartment.

If you are measuring water temperature, choose a location where the sensor will be in contact with the water at all times.

Installation

Mounting on the transom

CAUTION : Mount the sensor as close to the centerline (keel) of the boat as possible to ensure the sensor remains in the water when the boat is turning (Figure1).

CAUTION: Fiberglass hull —Minimize surface cracking by running the drill in reverse until the gelcoat is penetrated.

CAUTION : If the sensor came with a connector, do not remove it to ease cable routing. If the cable must be cut and spliced, use Airmar's splash-proof Junction Box No. 33-035 and follow the instructions provided. Removing the waterproof connector or cutting the cable, except when using a water-tight junction box, will void the sensor warranty.

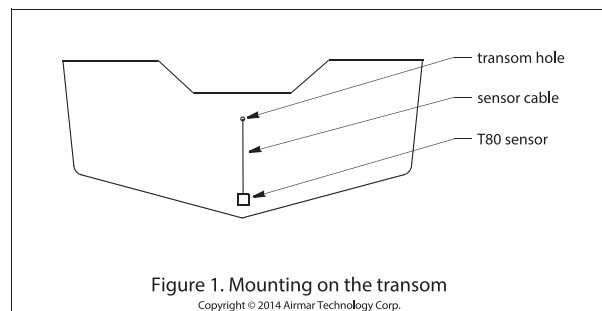

APPX. 2 INSTALLATION OF TEMPERATURE SENSORS

Mount the sensor near the centerline and close to the bottom of the transom.

Route the sensor cable over the transom, through a drain hole, or through a hole that you have drilled in the transom above the waterline.

1. Place the sensor against the hull and mark the position of the screw holes with a pencil.
2. Using a 3 mm or 1/8" drill bit, drill pilot holes at the marked locations, 10mm (3/8") deep.
3. Apply marine sealant to the threads of the purchased screws to prevent water from seeping into the transom.
4. Screw the temperature sensor to the hull.
5. If a hole must be drilled through the transom, choose a location well above the waterline. Check for obstructions such as trim tabs, pumps, or wiring inside the hull. Mark the location with a pencil. Drill a hole through the transom using the appropriate size hole saw or spade bit (to accommodate the connector). Do NOT remove the connector.
6. Route the cable over or through the transom.
7. On the outside of the hull, secure the cable against the transom using a purchased cable clamp(s). Mark the position of the screw hole(s) with a pencil.
8. Using a 3 mm or 1/8" drill bit, drill a pilot hole(s) at the marked locations, 10mm (3/8") deep.
9. Apply marine sealant to the threads of the screw(s) to prevent water from seeping into the transom.
10. Fasten the cable clamp(s) in place.
11. If a hole has been drilled through the transom, apply marine sealant to the space around the cable leading through the transom.

Cable Routing & Connecting

1. Route the cable to the instrument, being careful not to tear the cable jacket when passing it through the bulkhead(s) and other parts of the boat. Use grommet(s) to reduce chafing. To reduce electrical interference, separate the sensor cable from other electrical wiring and sources of noise. Coil any excess cable and secure it in place with cable ties to prevent damage.
2. Refer to the instrument owner's manual to connect the sensor to the instrument.

Replacement Sensor & Parts

The information needed to order a replacement sensor is printed on the cable tag. Do not remove this tag. When ordering, specify the part number and date. For convenient reference, record this information at the top of page AP-11.

Obtain parts from your instrument manufacturer or marine dealer.

Gemeco

USA

Tel: 803-693-0777
email: sales@gemeco.com

Airmar EMEA

Europe, Middle East, Africa

Tel: +33.(0)2.23.52.06.48
email: sales@airmar-emea.com



35 Meadowbrook Drive, Milford, New Hampshire 03055-4613, USA
• www.airmar.com



Copyright © 2014 - 2018 Airmar Technology Corp. All rights reserved.

APPX. 3 TRANSDUCER LIST

The tables below show all available transducers, whether they are compatible with the functions listed, and connection port.

Standard transducers (CW narrow band)

Model	ACCU-FISH™	Bottom Discrimination	Port to be connected	Power Rating	
520-5PSD	Yes	Yes	XDR1	600 W	
520-5MSD	Yes	Yes			
525-5PWD	Yes	Yes			
525STID-MSD	Yes	Yes			
525STID-PWD	Yes	Yes			
520-PLD	Yes	Yes			
525T-BSD	Yes	Yes			
525T-PWD	Yes	Yes			
525T-LTD/12	Yes	Yes			
525T-LTD/20	Yes	Yes			
SS60-SLTD/12	Yes	Yes			
SS60-SLTD/20	Yes	Yes			
526TID-HDD	Yes	Yes			XDR1*
TM260	Yes	Yes			
50/200-1T	Yes	Yes			
50B-6	No	No			
50B-6B	No	No			
200B-5S	No	No			

* : Connect with the matching box MB-1100 (optional supply).

CHIRP transducers (single frequency)

Model	ACCU-FISH™	Bottom Discrimination	Port to be connected	Power Rating	
B75L	No	No	XDR1	300 W	
B150M	No	No			
P95M	No	No			
SS75L	No	No			
TM150M	No	No			
B75H	No	No			600 W
B75HW	No	No			
B75M	No	No			
B785M	No	No			
P75M	No	No			
SS75H	No	No			
SS75M	No	No			
TM165HW	No	No			
B175H	No	No		1 kW	
B175HW	No	No			
B175L	No	No			

APPX. 3 TRANSDUCER LIST

Model	ACCU-FISH™	Bottom Discrimination	Port to be connected	Power Rating
B175M	No	No	XDR1	1 kW
B175MW	No	No		
B285HW	No	No		
B285M	No	No		
M285HW	No	No		
SS175H	No	No		
SS175HW	No	No		
SS175L	No	No		
SS175M	No	No		
SS175MW	No	No		
TM185HW	No	No		
TM185M	No	No		
TM185MW	No	No		

Side Scan transducers

Model	ACCU-FISH™	Bottom Discrimination	Port to be connected	Power Rating
225T-TM904	No	No	XDR2/SIDE SCAN*	150 W
225T-SS904	No	No		
225T-PR904	No	No		
455T-TM903	No	No		
455T-SS903	No	No		
455T-PR903	No	No		

*: Connect directly to the XDR2/SIDE SCAN port.

Combined transducers

Model	ACCU-FISH™	Bottom Discrimination	Port to be connected	Power Rating
165T-50/200-SS260	No	No	XDR1*	1 kW
165T-50/200-TM260	No	No		

*: Connect directly to the XDR1 port.

表1 TABLE 1

寸法区分 (mm) DIMENSION	公差 (mm) TOLERANCE
L ≤ 50	±1.5
50 < L ≤ 100	±2.5
100 < L ≤ 500	±3

4-取付穴位置
PILOT HOLES

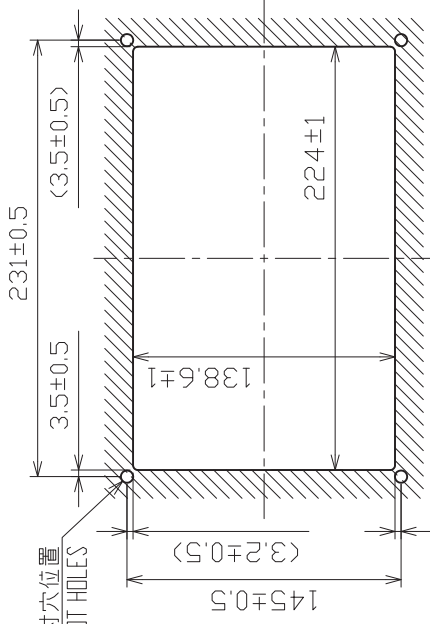

取付穴寸法
CUTOUT DIMENSIONS

3.2±0.5

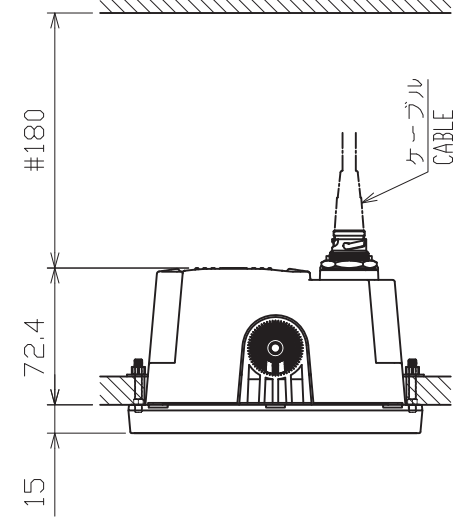
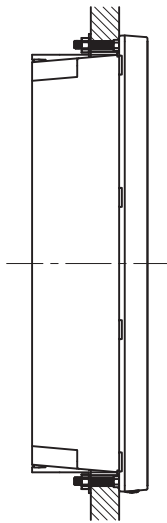

#180

72.4

15

警告ラベル
WARNING LABEL

(A)

241.5

(231)

取付穴
4-φ6.5
FIXING HOLES

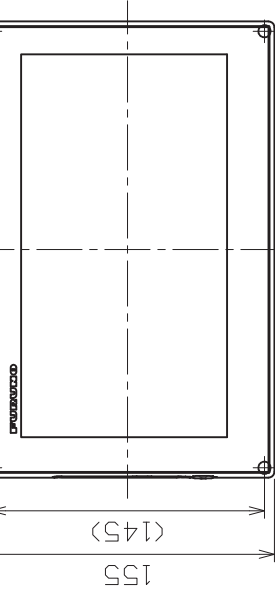

型式銘板
NAMEPLATE

通風口
AIR VENT

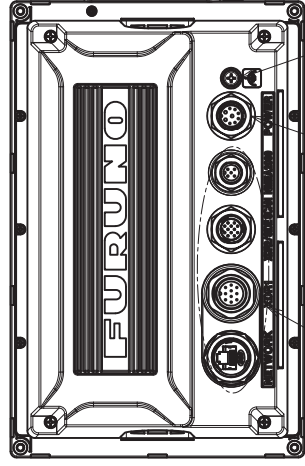

信号コネクタ
SIGNAL CONNECTOR

電源コネクタ
POWER CONNECTOR

アース端子
GND TERMINAL

NOTE

1. TABLE 1 INDICATES TOLERANCE OF DIMENSIONS WHICH IS NOT SPECIFIED.
2. #: MINIMUM SERVICE CLEARANCE.
3. BULKHEAD THICKNESS (A): $5 \leq B \leq 15$.
4. USE SUPPLIED METRIC STUDS M4x20 WITH WASHERS AND M4 NUTS.

注 記

- 1) 指定外の寸法公差は表1による。
- 2) 井印寸法は最小サービス空間寸法とする。
- 3) 壁の厚さ(A)は最小5、最大15とする。
- 4) 付属のM4x20スタッドボルト、ワッシャー、およびM4ナットを使用すること。

DRAWN	10/Dec/2025 S.HAN	TITLE	TZMAP9/TZT9E	
CHECKED	10/Dec/2025 R.Fujiyama	名称	マルチファンクションディスプレイ (埋込装備)	
APPROVED	10/Dec/2025 A. Murao	外寸図		
SCALE	MAX 1.98 kg	重量はケーブルを含みます MAX 1.98 kg	NAME	MULTI FUNCTION DISPLAY (FLUSH MOUNT)
DWG No.	C4535-G01-A	図番	H488MN01A02	OUTLINE DRAWING



表1 TABLE 1

寸法区分 (mm) DIMENSION	公差 (mm) TOLERANCE
L ≤ 50	±1.5
50 < L ≤ 100	±2.5
100 < L ≤ 500	±3

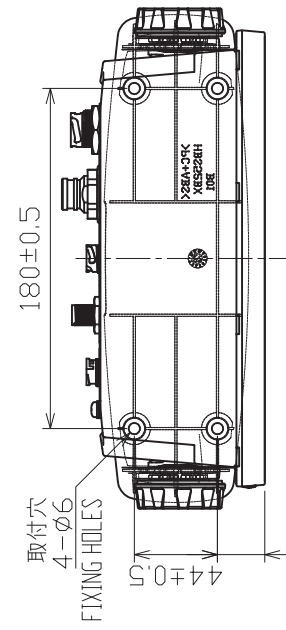
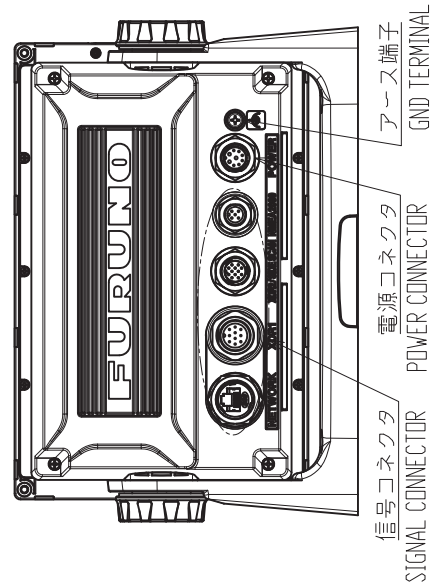
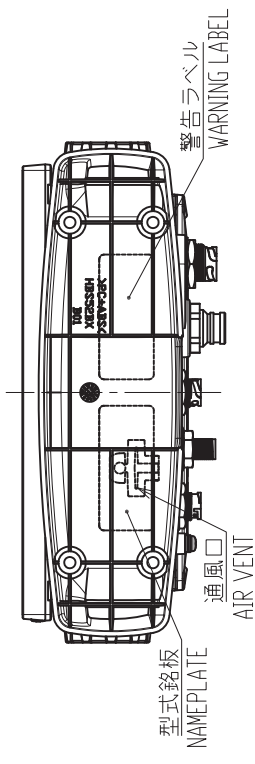
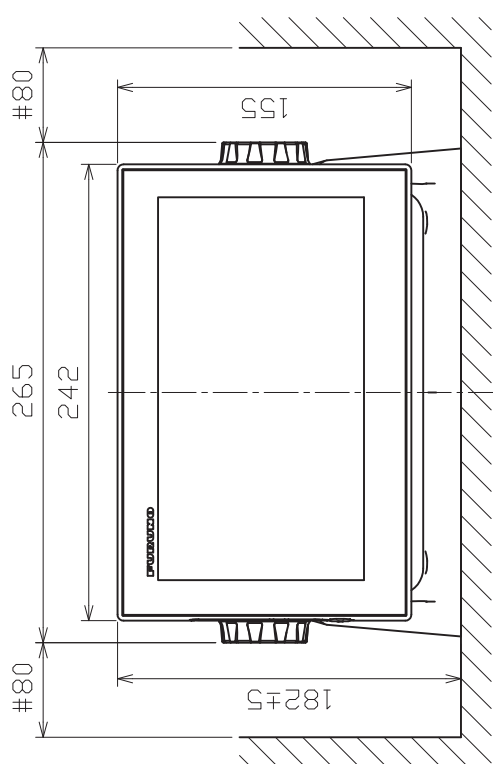
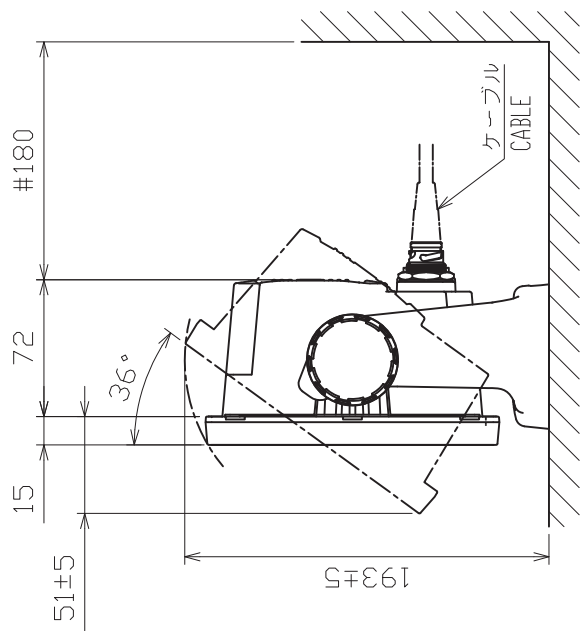

NOTE

1. TABLE 1 INDICATES TOLERANCE OF DIMENSIONS WHICH IS NOT SPECIFIED.
2. # MINIMUM SERVICE CLEARANCE.
3. USE TAPPING SCREWS M4.8x22 FOR FIXING THE UNIT.

DRAWN	10/Dec/2025 S.HAN	TITLE	TZMAP9/TZ19E	
CHECKED	10/Dec/2025 R.Fujiyama	名称	マルチファンクションディスプレイ (卓上装備)	
APPROVED	10/Dec/2025 A. Murao	外寸図		
SCALE	1/20	質量はハンガートップを含む。 MASS 2.201 kg REF.No. H488M01A02	NAME	MULTI FUNCTION DISPLAY (TABLETOP MOUNT)
DWG.No.	C4535-G02-A			OUTLINE DRAWING

注記

- 1) 指定外の寸法公差は表1による。
- 2) #印寸法は最小サービス空間寸法とする。
- 3) 取付用ネジはトラス呼び径4.8×22を使用のこと。



表1 TABLE 1

寸法区分 (mm) DIMENSION	公差 (mm) TOLERANCE
L ≤ 50	±1.5
50 < L ≤ 100	±2.5
100 < L ≤ 500	±3

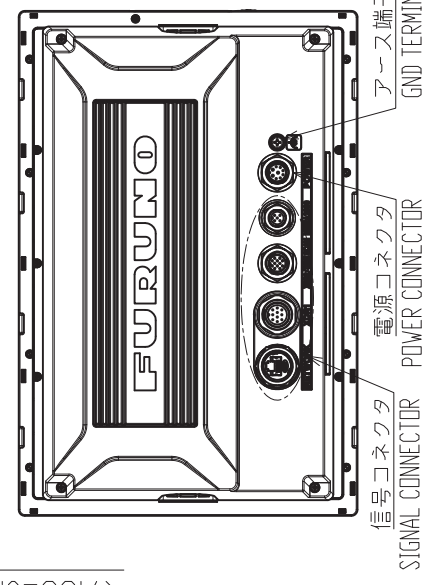
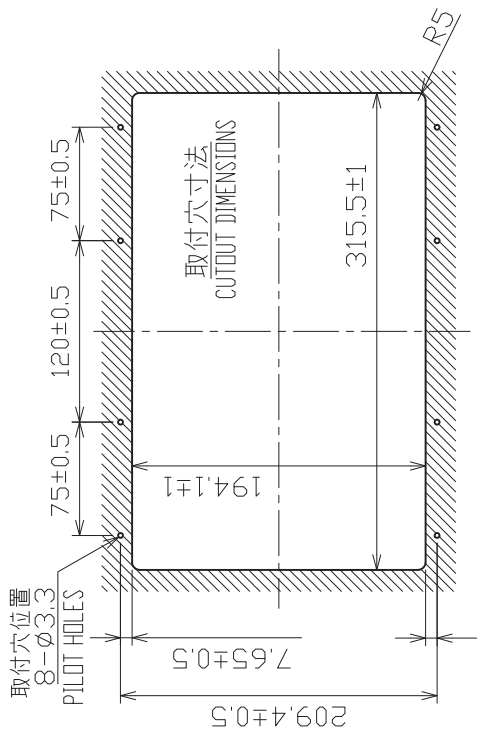
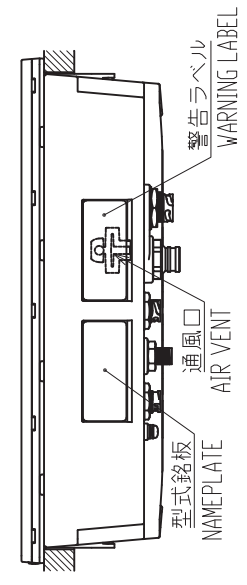
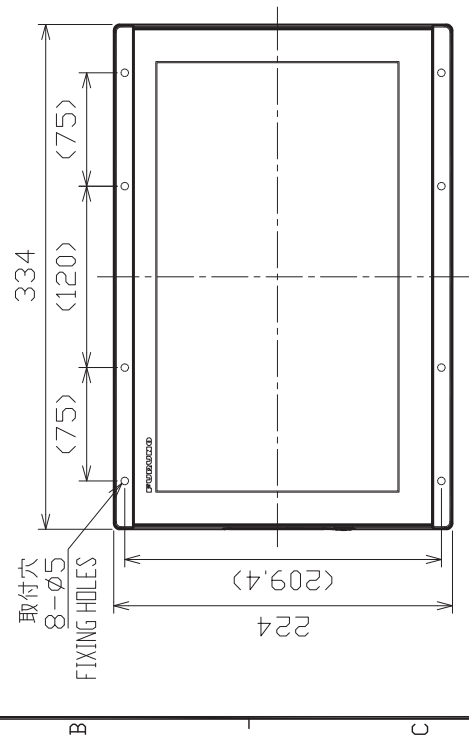
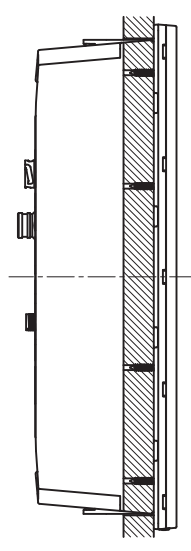
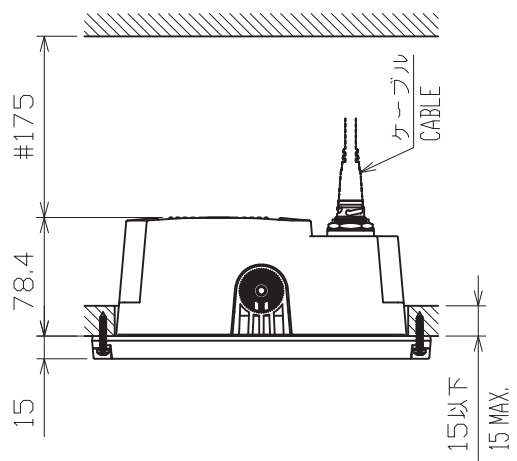

NOTE
 1. TABLE 1 INDICATES TOLERANCE OF DIMENSIONS WHICH IS NOT SPECIFIED.
 2. #: MINIMUM SERVICE CLEARANCE.
 3. USE TAPPING SCREWS M4.2x25 FOR FIXING THE UNIT.

DRAWN	10/Dec/2025	S. SHAN	TITLE	TZMAP13/TZ113E
CHECKED	10/Dec/2025	R. Fujiyama	名称	マルチファンクションディスプレイ (埋込装備)
APPROVED	10/Dec/2025	A. Murao	外寸図	
SCALE	1/100	質量はケーブルを含まず MASS DOES NOT INCLUDE CABLE.	NAME	MULTI FUNCTION DISPLAY (FLUSH MOUNT)
DWG. No.	C4536-G01-A	REF. No.	H516MN01A01	OUTLINE DRAWING

注記
 1) 指定外の寸法公差は表1による。
 2) #印寸法は最小サービス空間寸法とする。
 3) 取付用ネジはトラスタップピンネジ呼び径4.2x25を使用のこと。

FURUNO ELECTRIC CO., LTD.

9-52, Ashihara-cho,
Nishinomiya, 662-8580, JAPAN

·FURUNO Authorized Distributor/Dealer

All rights reserved.

A : DEC. 2025
A2 : MAY.27, 2026

Pub. No. IME-45330-A2
(AIHA) TZT9E/TZT13E

