

FURUNO

OPERATOR'S MANUAL

SATELLITE COMPASS

SC-70

Model

SC-130

FURUNO ELECTRIC CO., LTD.

9-52 Ashihara-cho,
Nishinomiya, 662-8580, JAPAN

• FURUNO Authorized Distributor/Dealer

All rights reserved. Printed in Japan

Pub. No. OME-72820-S2

(TEHI) SC-70/SC-130

A : JAN. 2017
S2 : APR. 14, 2026



0 0 0 1 0 0 0 5 6 2 0

IMPORTANT NOTICES

General

- This manual has been authored with simplified grammar, to meet the needs of international users.
- The operator of this equipment must read and follow the instructions in this manual. Wrong operation or maintenance can void the warranty or cause injury.
- Do not copy any part of this manual without written permission from FURUNO.
- If this manual is lost or worn, contact your dealer about replacement.
- The contents of this manual and the equipment specifications can change without notice.
- The example screens (or illustrations) shown in this manual can be different from the screens you see on your display. The screens you see depend on your system configuration and equipment settings.
- Save this manual for future reference.
- Any modification of the equipment (including software) by persons not authorized by FURUNO will void the warranty.
- The following concern acts as our importer in Europe, as defined in DECISION No 768/2008/EC.
 - Name: FURUNO EUROPE B.V.
 - Address: Rotterdamseweg 30A, 2921 AP, Krimpen aan den IJssel, The Netherlands
- The following concern acts as our importer in UK, as defined in SI 2016/1025 as amended SI 2019/470.
 - Name: FURUNO (UK) LTD.
 - Address: West Building Penner Road Havant Hampshire PO9 1QY, U.K.
- All brand, product names, trademarks, registered trademarks, and service marks belong to their respective holders.

How to dispose of this product

Dispose of this product according to local regulations for the disposal of industrial waste. For disposal in the USA, see the homepage of the Electronics Industries Alliance (<http://www.eiae.org/>) for the correct method of disposal.

How to dispose of a used battery

Some FURUNO products have a battery(ies). To see if your product has a battery, see the chapter on Maintenance. To dispose of a used battery, tape the + and - terminals of the battery before disposal to prevent fire, heat generation caused by short circuit.

In the European Union

The crossed-out trash can symbol indicates that all types of batteries must not be discarded in standard trash, or at a trash site. Take the used batteries to a battery collection site according to your national legislation and the Batteries Directive 2006/66/EU.

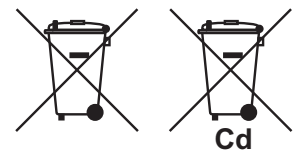

In the USA

The Mobius loop symbol (three chasing arrows) indicates that Ni-Cd and lead-acid rechargeable batteries must be recycled. Take the used batteries to a battery collection site according to local laws.

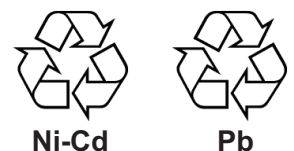

In the other countries

There are no international standards for the battery recycle symbol. The number of symbols can increase when the other countries make their own recycle symbols in the future.



SAFETY INSTRUCTIONS

The operator and installer must read the applicable safety instructions before attempting to operate or install the equipment. Failure to comply with these safety instruction may cause injury, loss of life or damage to the equipment.

DANGER	Indicates a potentially hazardous situation which, if not avoided, will result in death or serious injury.
WARNING	Indicates a potentially hazardous situation which, if not avoided, could result in death or serious injury.
CAUTION	Indicates a potentially hazardous situation which, if not avoided, can result in minor or moderate injury.





Warning, Caution	Prohibitive Action	Mandatory Action
------------------	--------------------	------------------

Safety instructions for the installer

WARNING
Turn off the power at the mains switchboard before beginning the installation. Fire, electrical shock or serious injury can result if the power is left on or is applied while the equipment is being installed.
ELECTRICAL SHOCK HAZARD Do not open the equipment unless totally familiar with electrical circuits and service manual. Only qualified personnel should work inside the equipment.
Use the specified power cable. Fire can result if an incorrect cable is used.
Do not disassemble or modify the equipment. Fire, electrical shock or serious injury can occur.
Do not install the equipment where it may get wet from rain or water splash. Water in the equipment can cause fire, electrical shock or damage to the equipment.

CAUTION		
	Ground the equipment to prevent electrical shock and mutual interference.	
	Observe the following safe compass distances to prevent interference to a magnetic compass:	
	Standard compass	Steering compass
Display Unit SC-702	0.50 m	0.30 m
Junction Box SC-701	1.35 m	0.85 m
Antenna Unit SC-703	0.40 m	0.30 m
Antenna Unit SC-1303	0.30 m	0.30 m
Remote Display Unit RD-50	0.45 m	0.30 m
Remote Display Unit RD-20	1.25 m	0.80 m
AC/DC Power Supply PR-240	0.90 m	0.60 m
AC/DC Power Supply PR-241	0.85 m	0.55 m

Safety instructions for the operator

 WARNING	
	<p>ELECTRICAL SHOCK HAZARD Do not open the equipment unless totally familiar with electrical circuits and service manual.</p> <p>Only qualified personnel should work inside the equipment.</p>
	<p>Do not disassemble or modify the equipment.</p> <p>Fire, electrical shock or serious injury can occur.</p>
	<p>Turn off the power immediately if water leaks into the equipment or smoke or fire is coming from the equipment.</p> <p>Failure to turn off the equipment can cause fire or electrical shock. Contact a FURUNO agent for service.</p>
	<p>Use the correct fuse.</p> <p>A wrong fuse can cause fire or serious damage to the equipment.</p>

<h2>CAUTION</h2>	
	<p>No single navigation aid (including this unit) should ever be relied upon as the exclusive means for navigating your vessel.</p> <p>The navigator is responsible for checking all aids available to confirm his position. Electronic aids are intended to assist, not replace, the navigator.</p>

WARNING LABEL

A warning label is attached to the Junction Box (SC-701). Do not remove the label. If the label is missing or damaged, contact a FURUNO agent or dealer about replacement.

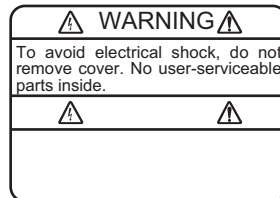

Unit: Junction Box (SC701)
Name: Warning Label (1)
Type: 86-003-1011-3
CodeNo.: 100-263-233-10

About the TFT LCD

The TFT LCD is constructed using the latest LCD techniques, and displays 99.99% of its pixels. The remaining 0.01% of the pixels may drop out or be constantly lit. Additionally, the LCD has a limited viewing angle and may flicker. However, these are not indications of malfunction.

TABLE OF CONTENTS

FOREWORD	vii
SYSTEM CONFIGURATION	ix
EQUIPMENT LIST	x
1. INSTALLATION	1-1
1.1 How to Install the Antenna Units	1-1
1.1.1 How to install the SC-703 Antenna Unit	1-3
1.1.2 How to install the SC-1303 Antenna Unit	1-5
1.1.3 How to retrofit from SC-603/SC-1203	1-6
1.2 How to Install the Junction Box (SC-701)	1-7
1.3 How to Install the Display Unit (SC-702)	1-8
1.3.1 How to install the SC-702 on a desktop or overhead	1-8
1.3.2 How to flush mount the SC-702	1-9
1.4 How to Install the Remote Display Unit (option)	1-10
1.5 Wiring	1-11
1.5.1 How to fabricate the cables	1-12
1.5.2 How to secure and waterproof the cable connections	1-14
1.5.3 How to fabricate the WAGO connectors	1-15
1.5.4 How to connect the Antenna Unit (SC-703/SC-1303)	1-15
1.5.5 How to connect the Junction Box (SC-701)	1-17
1.5.6 How to connect the Display unit (SC-702)	1-20
1.5.7 How to connect the Remote Display Unit (option)	1-23
1.6 Initial Settings	1-24
1.6.1 Main menu	1-25
1.6.2 How to set vessel dimensions, antenna location and CCRP	1-26
1.6.3 How to apply offsets for heading/pitch/heave/roll/position	1-28
1.6.4 How to set the heave output delay	1-28
1.7 How to Access and Use the [SERVICE] Menu	1-29
1.8 I/O Menu Settings	1-29
1.9 Initial Settings for the Remote Display	1-30
2. OPERATION	2-1
2.1 Controls Overview	2-1
2.2 How to Turn the Power On/Off	2-2
2.3 How to Adjust the Brilliance, Change the Background Color	2-3
2.3.1 How to adjust the screen and key panel brilliance	2-3
2.3.2 How to change the background and text color	2-3
2.4 Menu Overview	2-4
2.5 LIST Screens Overview	2-5
2.6 Display Modes Overview	2-5
2.6.1 Icons and indications	2-6
2.7 GPS Display Mode	2-7
2.7.1 GPS coordinates screen (main screen)	2-7
2.7.2 GPS integrity screen	2-8
2.7.3 BEACON INFO/TYPE 16 MESSAGE screen	2-9
2.8 THD Display Mode	2-10
2.8.1 HDG data screen	2-10
2.8.2 Compass Rose data screen	2-11
2.8.3 ROT data screen	2-12
2.8.4 HDG/ROT split screen	2-12
2.8.5 HDG/TIME/COG/SOG split screen	2-13

2.8.6	THD integrity screen.....	2-13
2.9	ROTI Display Mode	2-14
2.9.1	ROTI analog meter screen	2-14
2.9.2	ROTI Display for RD-50/RD-20 (option).....	2-15
2.10	SPD Display Mode (Non-IMO types only)	2-15
2.10.1	Speed and distance display screen.....	2-15
2.10.2	Navigational data screen.....	2-16
2.11	Alerts	2-16
2.11.1	What is an Alert?	2-16
2.11.2	How to acknowledge alerts	2-18
2.11.3	How to silence alerts	2-18
2.11.4	How to enable/disable the aural alert (Non-IMO type only).....	2-19
2.11.5	How to access the alert list.....	2-19
2.11.6	How to access the alert log	2-21
2.11.7	Responsibility transfer alert	2-22
2.11.8	Alert escalation.....	2-23
2.11.9	Alert continuation.....	2-23
2.11.10	UTC de-synchronization and alert output.....	2-23
2.12	How to View the Connected Devices	2-24
2.13	DISPLAY Menu	2-25
2.13.1	How To Change the Display Color	2-25
2.13.2	How to Change the Units of Measurement	2-25
2.13.3	How To Use The Smoothing Menu	2-26
2.13.4	How to set the number of digits after a decimal point	2-26
2.13.5	How to Set Geodetic Data	2-27
2.13.6	How to Reset the Trip Meter	2-27
2.13.7	How to Adjust the Date and Time.....	2-27
2.13.8	How to Set the Display Language	2-28
2.14	GNSS Menu	2-28
2.14.1	How to select the positioning system to use	2-28
2.14.2	How to set the positioning conditions	2-29
2.14.3	How to Set Up DGPS/SBAS	2-30
2.14.4	How to Set Up RAIM	2-31
2.14.5	How to set the rollover timing	2-31
2.15	How to Set Up the I/O Menu.....	2-32
2.15.1	How to set up serial data output.....	2-32
2.15.2	How to set up LAN data output	2-33
2.15.3	How to set up data sources (data input).....	2-34
2.15.4	How to use the input/output logs	2-35
2.15.5	How to restart heading output	2-37
2.15.6	How to use backup HDG output.....	2-38
2.15.7	How to change the speed reference (Non-IMO types only)	2-38
2.15.8	How to hold course at low speeds.....	2-38
2.16	SENSOR Menu	2-39
2.16.1	OTHER menu	2-39
2.16.2	SENSOR STATUS menu	2-39
2.17	SYSTEM Menu.....	2-40
2.17.1	Simulation mode.....	2-40
2.17.2	SYSTEM SOUND menu.....	2-43
2.17.3	SYSTEM LOG menu	2-43
2.17.4	How to save a sensor log	2-44
2.17.5	How to clear display settings and GPS memory	2-44
2.17.6	How to restore IEC61162-450 default ethernet settings	2-45
2.18	ROTI Display Operations (RD-50/RD-20, option).....	2-45

TABLE OF CONTENTS

3. NMEA2000 I/O DATA	3-1
3.1 Input Data.....	3-1
3.2 Output Data.....	3-1
4. MAINTENANCE, TROUBLESHOOTING.....	4-1
4.1 Preventative Maintenance.....	4-1
4.2 Replacement of Fuse	4-1
4.3 Basic Troubleshooting.....	4-2
4.4 Maintenance Menu.....	4-3
4.4.1 How to find unit information.....	4-3
4.4.2 How to Backup User Settings	4-3
4.5 Diagnostic Tests.....	4-5
4.5.1 Memory test	4-5
4.5.2 Keyboard test.....	4-6
4.5.3 LCD test	4-6
4.5.4 Automatic Test	4-7
4.5.5 Sound test.....	4-7
APPX. 1 MENU TREE	AP-1
APPX. 2 ALERT LIST.....	AP-4
APPX. 3 ABBREVIATIONS AND UNITS.....	AP-8
APPX. 4 ICONS AND SYMBOLS	AP-10
APPX. 5 GEODETIC CHART CODES	AP-11
APPX. 6 WHAT IS SBAS?.....	AP-12
APPX. 7 DIGITAL INTERFACE (IEC 61162-1 EDITION 5)	AP-13
APPX. 8 PARTS LIST/LOCATION.....	AP-25
APPX. 9 JIS CABLE GUIDE	AP-28
SPECIFICATIONS	SP-1
PACKING LISTS.....	A-1
OUTLINE DRAWINGS.....	D-1
INTERCONNECTION DIAGRAMS	S-1
INDEX.....	IN-1

FOREWORD

A Word to the Owner of the SC-70/SC-130

FURUNO Electric Company thanks you for purchasing the FURUNO SC-70 or SC-130 Satellite Compass™. We are confident you will discover why the FURUNO name has become synonymous with quality and reliability.

Since 1948, FURUNO Electric Company has enjoyed an enviable reputation for quality and reliability throughout the world. This dedication to excellence is furthered by our extensive global network of agents and dealers.

Your equipment is designed and constructed to meet the rigorous demands of the marine environment. However, no machine can perform its intended function unless properly operated and maintained. Please carefully read and follow the operation and maintenance procedures in this manual.

We would appreciate feedback from you, the end-user, about whether we are achieving our purposes.

Thank you for considering and purchasing FURUNO.

Features

The SC-70/SC-130 is a new Satellite Compass™ designed with FURUNO advanced GPS kinematic technology. This compass has a wide range of applications for both land and sea vessels.

The main features are:

- Meets the requirement for the following regulations: IMO MSC. 116(73), ISO 22090 Ed 2.0, IMO A. 694(17), IEC 60945, ISO 22090 Ed 2.0, IEC 61108-1 Ed 2.0, ISO 20672 Ed 1.0, IEC 61923-1 Ed 1.0, IEC 61923-2 Ed 1.0, IEC 61162-1 Ed 5.0, IEC 61162-2 Ed 1.0, IEC 61162-450 Ed 2.0, IEC 62288 Ed 2.0, IEC 62923-1, IEC 62923-2.
- Can output speed for any set location, allowing monitoring of bow and stern berthing speeds without the use of optional equipment.
- Perfect for use as a heading sensor for RADAR/ARPA, AIS, ECDIS and scanning SONARs.
- There are no mechanical parts such as gimbals or a rotating motor, thus the compass is free from routine maintenance.
- Geomagnetism does not affect the compass performance, making it usable on any vessel.
- No need for speed correction, unlike a gyrocompass.
- Short setting time
- Easily integrated into existing ship-board network via Ethernet.
- Remote Maintenance Service (RMS) ready, allowing hassle-free assistance when in port.
- Can be connected using existing antenna cabling (SC-50/60/110/120 only) by adding the optional conversion kit. Note that existing antennas units must be replaced. (Non-IMO type only)
- Uses multiple satellite types, eliminating the problem of not having enough satellites visible. (Non-IMO type only.)

Software used in this product

This product includes software to be licensed under the GNU General Public License (GPL) version 2.0, GNU Lesser General Public Software License (LGPL) version 2.0, Apache, BSD and others. The program(s) is/are free software(s), and you can copy it and/or redistribute it and/or modify it under the terms of the GPL version 2.0 or LGPL version 2.0 as published by the Free Software Foundation. Please access to the following URL if you need source codes:

https://www.furuno.co.jp/en/contact/cnt_oss_e01.html

CE/UKCA declaration

With regards to CE/UKCA declarations, please refer to our website (www.furuno.com), for further information about RoHS conformity declarations.

Disclosure of Information about China RoHS

With regards to China RoHS information for our products, please refer to our website (www.furuno.com).

Program numbers

Unit & PC Board	PCB/Application	Program No.*
Antenna Unit	MAIN	2051570-02.xx
	GNSS	48505230xx
Junction box	MAIN	2051562-02.xx
Display Unit	MAIN	2051566-02.xx
Remote Display Unit RD-50	Starter	2651006-01.xx
	Booter	2651007-01.xx
	Main	2651008-01.xx
Remote Display Unit RD-20	Starter	2651003-01.xx
	Booter	2651004-01.xx
	Main	2651005-01.xx

*: "xx" denotes version number.

SYSTEM CONFIGURATION

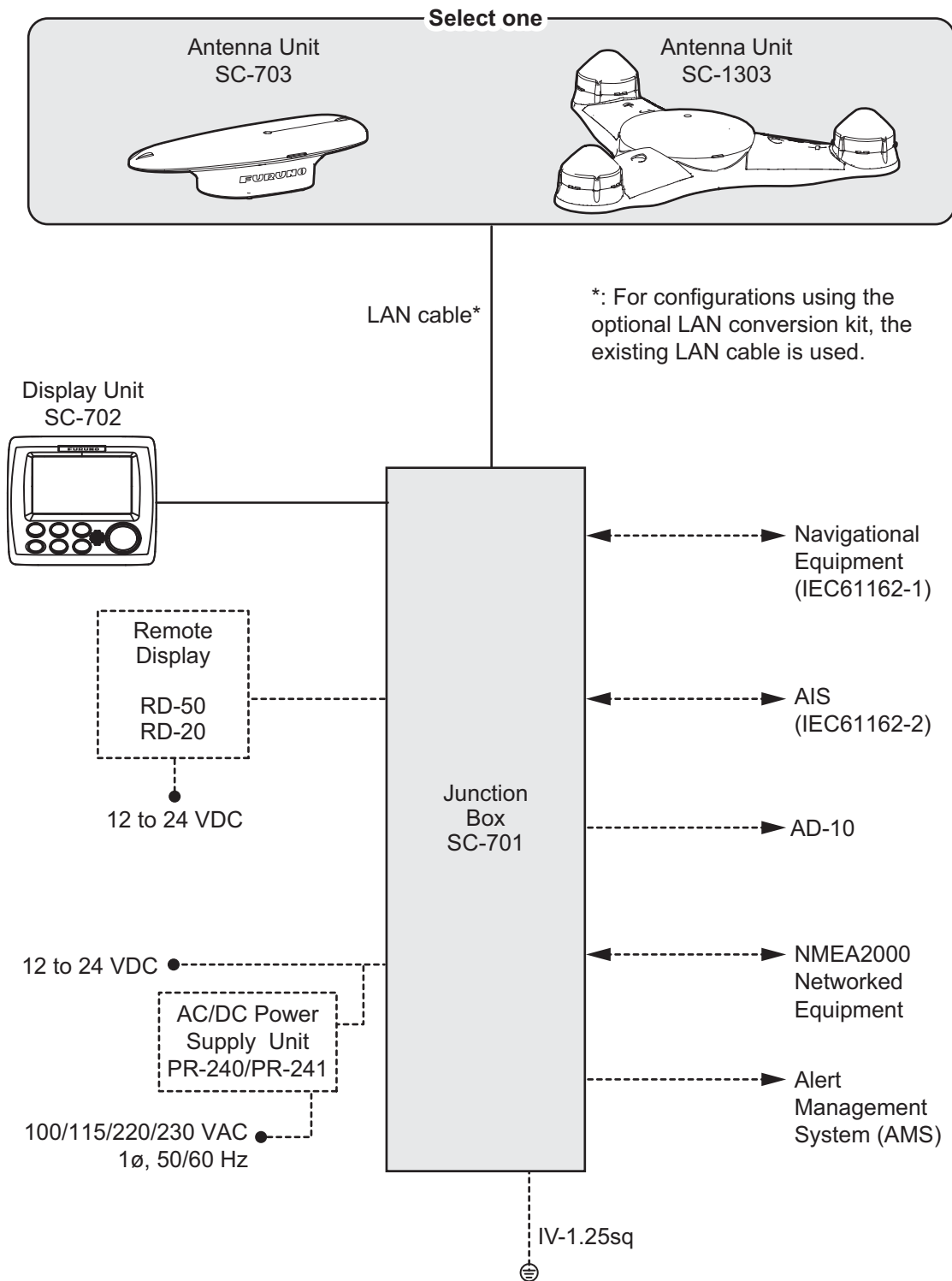

Environmental categories:

Antenna units:	Exposed to the weather.
Other units:	Protected from the weather.

—————: Standard supply
 - - - - -: Optional/local supply

EQUIPMENT LIST

Standard supply

Name	Type	Code No.	Qty.	Remarks
Antenna unit	SC-703	-	Select one	-
	SC-703-L			Contains LAN-Coax conversion kit.
	SC-1303			
	SC-1303-L			Contains LAN-Coax conversion kit.
Display Unit	SC-702	-	1	-
Junction Box	SC-701	-	Select one	-
	SC-701-L	-		Contains LAN-Coax conversion kit.
Installation materials	CP20-04300	000-033-318	Select one	LAN cable (30 m) for SC-701 to Antenna Unit connection.
	CP20-04310	000-033-319		LAN cable (40 m) for SC-701 to Antenna Unit connection.
	CP20-04320	000-033-320		LAN cable (50 m) for SC-701 to Antenna Unit connection.
	CP20-04340	000-033-322		LAN cable (30 m) for SC-701 to Antenna Unit connection. No armor, with connector attached.
	CP20-04360	000-033-324		LAN cable (30 m) for SC-701 to Antenna Unit connection. No armor, with separate connector.
	CP20-04370	000-035-430		LAN cable (10 m) for SC-701 to Antenna Unit connection, with separate connector.
	CP20-04380	000-035-431		LAN cable (15 m) for SC-701 to Antenna Unit connection, with separate connector.
	CP20-04500	000-035-432		LAN cable (10 m) for SC-701 to Antenna Unit connection, with connector attached.
	CP20-04510	000-035-433		LAN cable (15 m) for SC-701 to Antenna Unit connection, with connector attached.
	CP20-04520	000-035-508		LAN cable (10 m) for SC-701 to Antenna Unit connection, No armor, with separate connector.
	CP20-04530	000-035-509		LAN cable (15 m) for SC-701 to Antenna Unit connection, No armor, with separate connector.
	CP20-04540	000-035-510		LAN cable (10 m) for SC-701 to Antenna Unit connection, No armor, with connector attached.
	CP20-04550	000-035-511		LAN cable (15 m) for SC-701 to Antenna Unit connection, No armor, with connector attached.
	CP20-04201	001-514-460		1
CP20-04202	001-514-570	1	For SC-1303.	
CP20-04001	001-514-470	1	For SC-701.	

Name	Type	Code No.	Qty.	Remarks
Installation materials	CP20-04101	001-521-480	1	For SC-702.
	CP20-04100	000-035-376	Select one	For SC-702-E-1. 10 m cable.
	CP20-04110	000-035-377		For SC-702-E-3. 30 m cable.
Spare parts	SP20-01801	001-516-680	1	For SC-701. (Fuses × 2)
Accessories	FP19-01201	001-517-360	1	For SC-702. Front panel remover. (19-028-3124-1. Code: 100-340-471-10)

Optional supply

Name	Type	Code No.	Remarks
Interface Unit	IF-NMEA SC	000-011-469	For analog output.
AC/DC Power Supply Unit	PR-241	-	For 100 to 230 VAC
Ferrite Core	OP-86-11	001-594-450	For PR-241
Remote Display Unit	RD-50	-	-
	RD-20	-	-
Cable Assembly (For NMEA2000)	FRU-NMEA-PMM-02	001-592-330	For NMEA2000 equipment connection.
	FRU-NMEA-PMMFF-010	001-507-010	
	FRU-NMEA-PMMFF-020	001-507-030	
	FRU-NMEA-PMMFF-060	001-507-030	
LAN cable (For AMS or dual configurations)	FR-FTPC-CY *10M*	001-240-510	For AMS connection.
	FR-FTPC-CY *20M*	001-240-520	
	FR-FTPC-CY *30M*	001-240-530	
3 Pair Cable	Z-#26X2P+0.3SQX1PL30	000-192-277-10	For SC-702, 30 m
	Z-#26X2P+0.3SQX1PL10	000-192-276-10	For SC-702, 10 m
Connector (waterproof)	FRU-RJ-PLUG-ASSY	000-192-316-10	For connection between SC-701 and SC-703/SC-1303.
Bird Repellent Fixture	OP20-37	004-380-840	Single.
	OP20-36	004-380-830	Four pieces.
	OP20-49	001-482-870	Seven pieces.
Front Fixing Panel	OP24-35	001-247-240	For SC-702.
Water Proof Kit	OP05-139	001-426-500	For SC-702.
F_Mount Cushion Kit	OP05-141	001-436-880	For SC-702.
LAN_CNV kit	OP20-47	001-516-110	For SC-701.
	OP20-48	001-516-120	For SC-703/SC-1303.
Snow Cover Kit	OP20-51	001-525-960	For SC-703
Modular Connector	MPS588-C	001-459-840	For LAN cable.
Micro T-Connector	SS-050505-FMF-TS001	000-168-603-10	
Termination Resistor (Micro)	LTWMC-05BFFT-SL8001	000-168-605-10	
	LTWMC-05BMMT-SL8001	000-168-604-10	

This page is intentionally left blank.

1. INSTALLATION

This chapter covers the installation procedure and initial set up procedures and settings for the SC-70 and SC-130 systems.

Note: The settings and procedures outlined in this chapter are for technical personnel and should not be adjusted or changed by the user. If you require a change to any of these settings, contact your dealer.

NOTICE

Do not apply paint, anti-corrosive sealant or contact spray to coating or plastic parts of the equipment.

Those items contain organic solvents that can damage coating and plastic parts, especially plastic connectors.

1.1 How to Install the Antenna Units

General considerations

- Keep the length of the antenna cable in mind when selecting a mounting location.
- Select a location with minimal or no vibration.
- The sensor should be separated more than three meters from Inmarsat F/FB antennas. Select a location outside this transmission area.
- Do not loop the antenna cable or bundle the antenna cable with radio equipment cables. When these noise reductions are insufficient, adjust the squelch on the radio equipment.
- Select a location with obstructions to the radio waves.
- Select a location more than a meter from the floor/deck etc.
- Select a location with no local vibration or impact (including sympathetic vibrations due to engine or mast) for the GPS sensor in the antenna unit.

Installing the antenna above superstructures

It is recommended that the antenna is installed above all other superstructures on the vessel. The antenna can obtain an unobstructed view of the available satellites, regardless of the vessel heading. Failure to install the antenna above all other superstructures can cause shadows and multipath reflection problems.

The following figure shows an example of the antenna installed above all other superstructures.

1. INSTALLATION

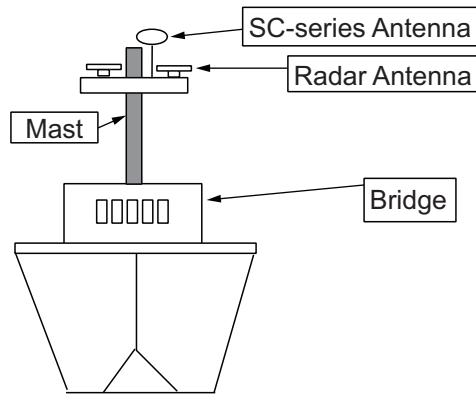

Installing the antenna below superstructures

Where the antenna is installed below superstructures on the vessel, shadows and multipath problems may occur on at least one heading, and possibly more. To avoid these problems where possible, follow the guidelines in this section.

Note: If the antenna is installed below any superstructure, the installation must be done over a two-day period. Contact your dealer for details.

At least 12 hours are required to capture offline data to measure multipath indexes and locate areas of shading.

- The horizontal separation between the antenna and masts must be as shown in the table below and the figure on the following page:

Mast diameter	Minimum separation distance
10 cm	1.5 m
30 cm	3 m

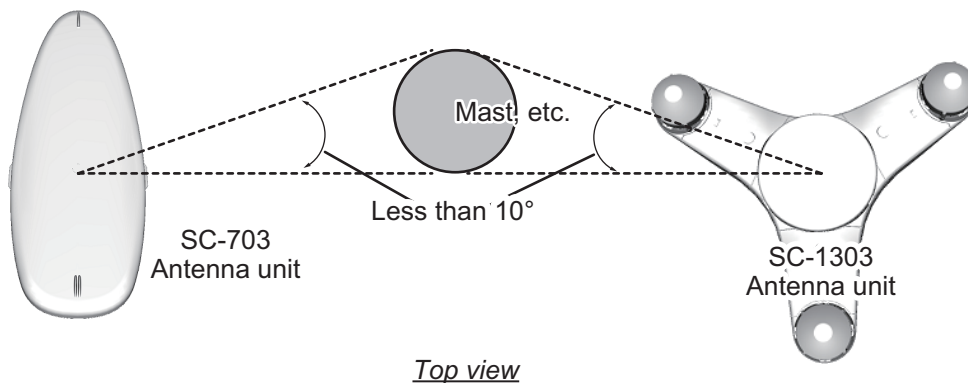
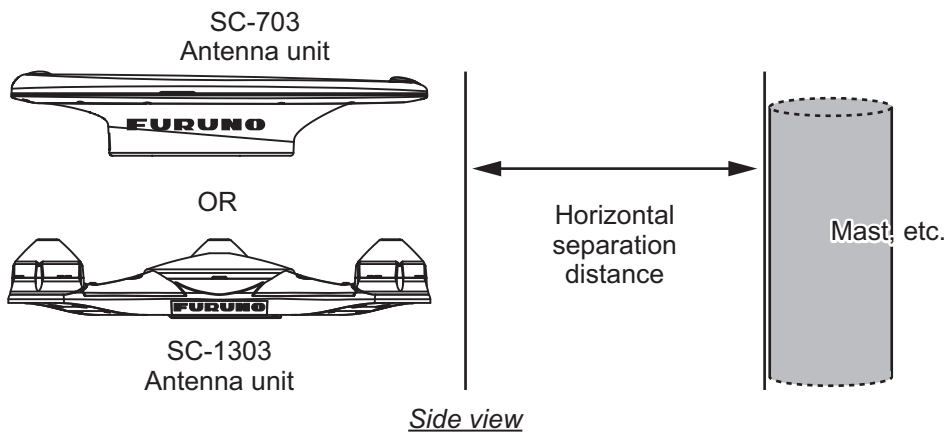

- The field of view above the antenna should be as shown in the figure below, $\pm 80^\circ$ against the zenith. To avoid reflections from masts and other obstacles, locate the antenna well away from shadows of the radar mast, etc.

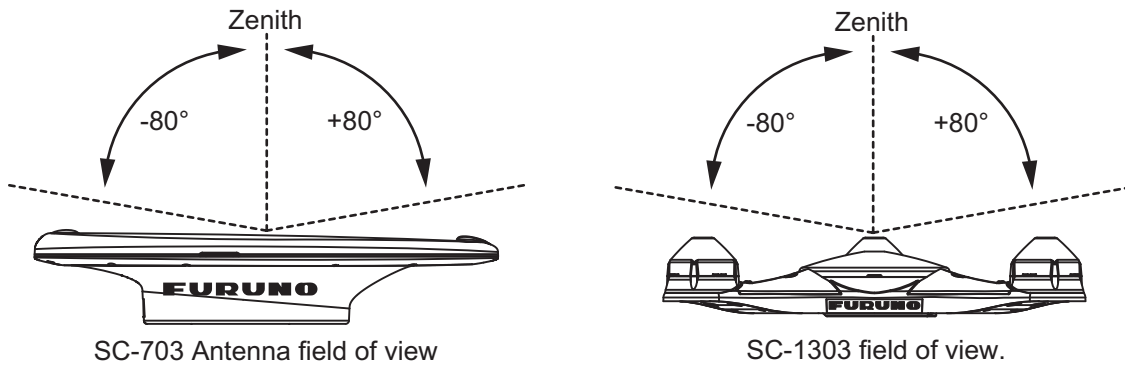

- Locate the antenna unit above the radar, out of the radar beam.

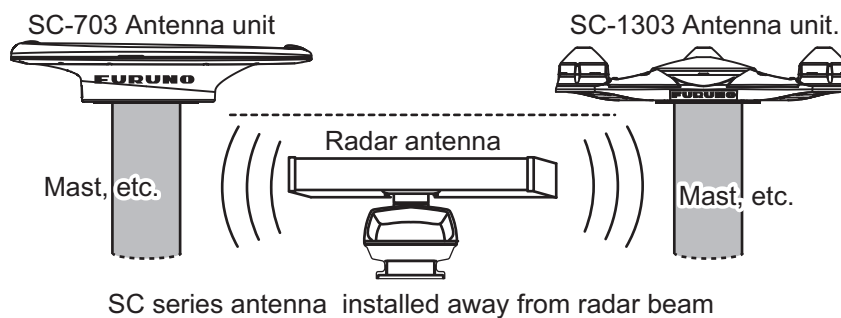

1.1.1 How to install the SC-703 Antenna Unit

Note 1: Where the installation location is inconvenient for cable connection, connect the cabling (see step 6) before securing the antenna unit to the mounting location.

Note 2: The bird deterrents can be attached to the antenna cover to prevent birds from landing on the cover. If it is more convenient to attach the bird deterrents before securing the antenna unit to the mounting location, do step 6 of the procedure below before fixing the antenna unit.

- Prepare a mounting platform in accordance with the outline drawing at the back of this manual. If corrosive material is used, take necessary anti-corrosion measures.

Note: Holes drilled into the mounting platform must be parallel with the fore-aft line of the vessel.
- Orient the antenna unit to face the bow, referring to the figure below. The antenna should be installed within $\pm 2.5^\circ$ of the bowline.

Note: The antenna cable must be routed via the indent at the rear of the base (see the following figure).

1. INSTALLATION

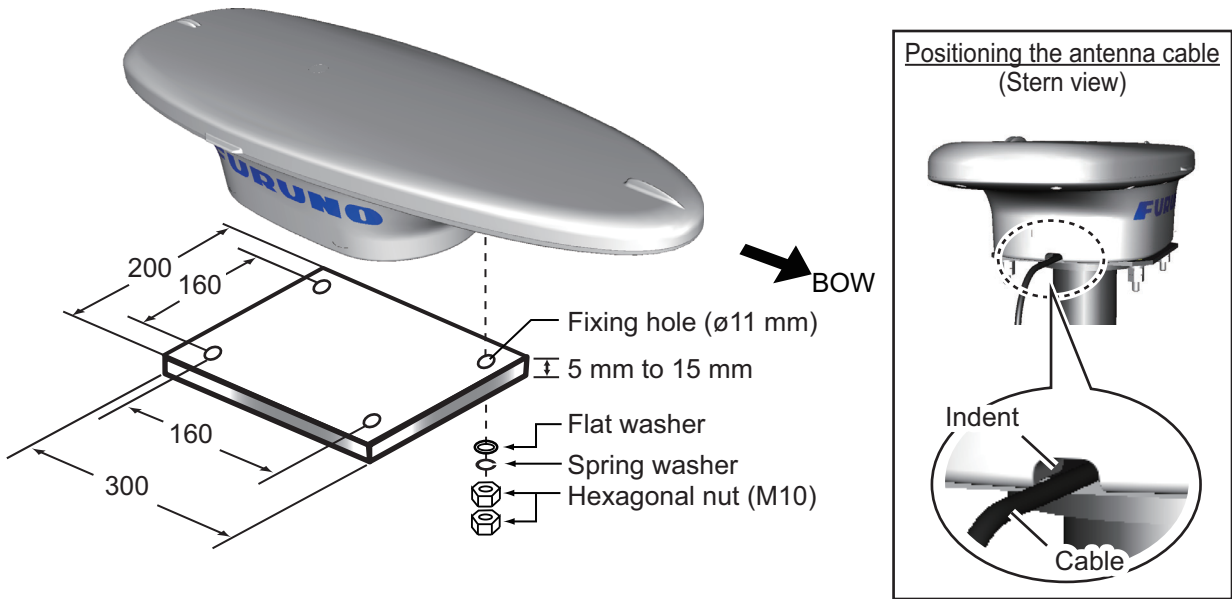

3. Secure the unit to the platform with four sets of M10 hex. nuts, spring washers and flat washers (all included as installation materials) with 20 ± 2 Nm torque.
Note 1: Take care not to crush the cabling when mounting the antenna to the platform.
Note 2: Take care not to cover the breathing hole on the antenna.
4. Coat the exposed parts of the nuts, bolts and washers with the Adhesive TB5211 (included) to prevent corrosion.

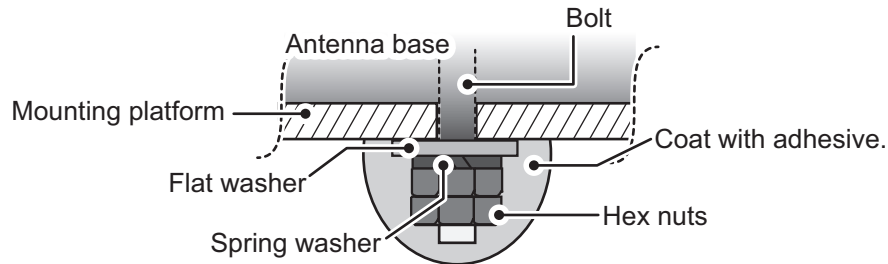

5. Connect the SC-703 cable to the cable from the SC-701, then waterproof the connection (see section 1.5.2 for the waterproofing procedure).
6. Remove the double-sided tape from the bird deterrents, then attach to the antenna cover. Coat around the bird deterrents with the Adhesive TB5211 (included).



7. Secure the cables to the mast (or superstructure) with cable ties, at regular intervals.

1.1.2 How to install the SC-1303 Antenna Unit

Note 1: Where the installation location is inconvenient for cable connection, connect the cabling (see step 6) before securing the antenna unit to the mounting location.

Note 2: The bird deterrents can be attached to the antenna cover to prevent birds from landing on the cover. If it is more convenient to attach the bird deterrents before securing the antenna unit to the mounting location, do step 7 before fixing the antenna unit.

1. Prepare a mounting platform in accordance with the outline drawing at the back of this manual. If corrosive material is used, take necessary anti-corrosion measures.

Note: Holes drilled into the mounting platform must be parallel with the fore-aft line of the vessel.

2. Orient the antenna unit to face the bow, referring to the figure below. The antenna should be installed within $\pm 2.5^\circ$ of the bowline.

Note: The antenna cable must be routed via the indent at the rear of the base (see figure on the following page).

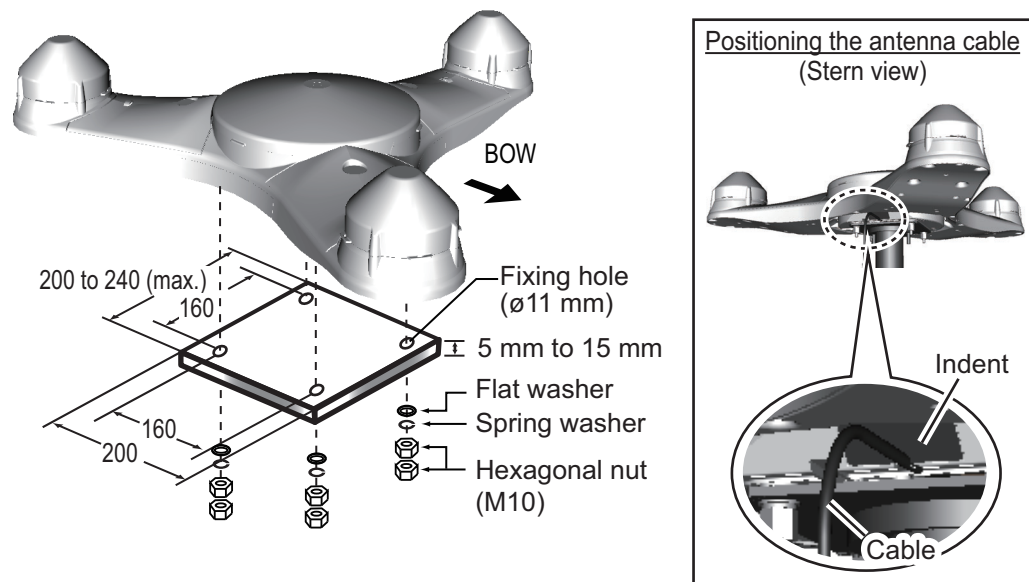

3. Coat the thread of the hex. bolts with silicone grease.
4. Fasten the unit to the platform with four sets of M10 hex. bolts, spring washers and flat washers with 20 ± 2 Nm torque.

Note: Take care not to crush the cabling when mounting the antenna to the platform.

5. Coat the exposed parts of the nuts, bolts and washers with the Adhesive TB5211 (included) to prevent corrosion.

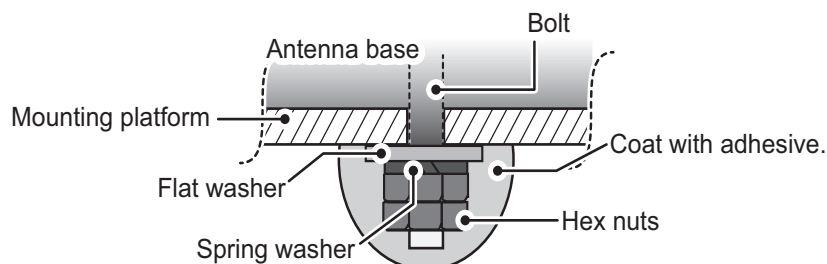

6. Connect the SC-1303 cable to the cable from the SC-701, then waterproof the connection (see section 1.5.2 for the waterproofing procedure).

1. INSTALLATION

- Remove the double-sided tape from the bird deterrents, then attach to the antenna cover. Coat around the bird deterrents with the Adhesive TB5211 (included).

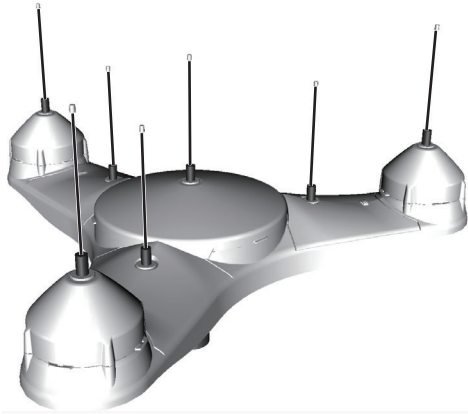

- Secure the cables to the mast (or superstructure) with cable ties, at regular intervals.

1.1.3 How to retrofit from SC-603/SC-1203

For retrofits from the SC-603 or SC-1203, the following attachments must be fabricated and attached to the mounting platform.

For SC-603 retrofits

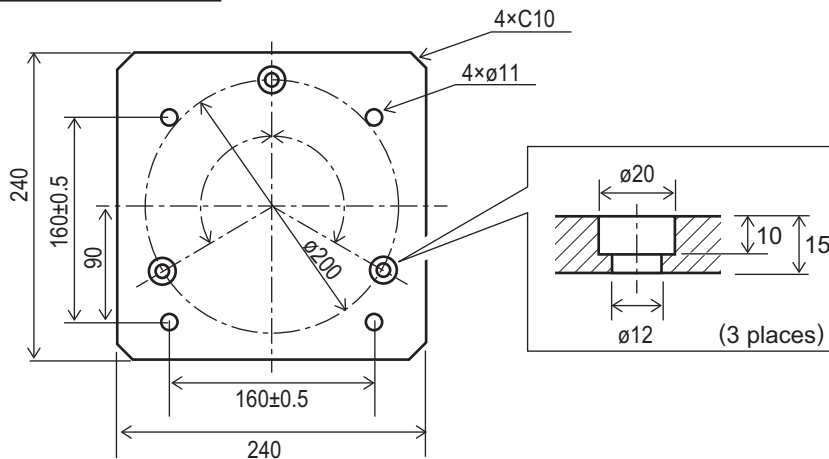

For SC-1203 retrofits

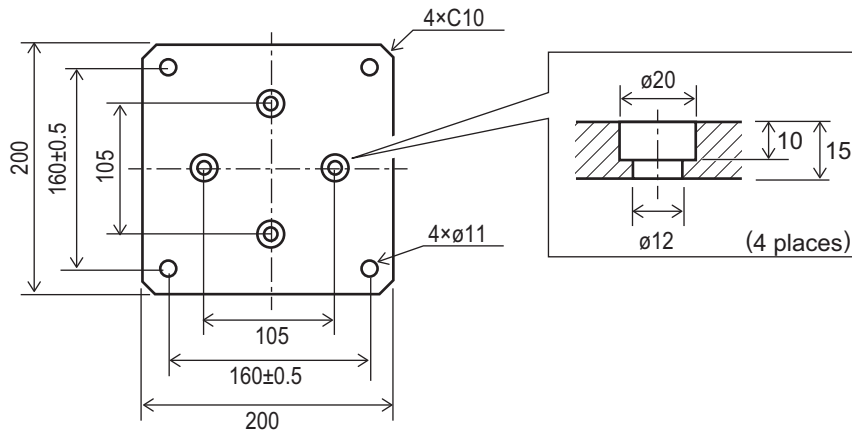

1.2 How to Install the Junction Box (SC-701)

The junction box can be mounted on the floor, bulkhead, on a desk/console or on the underside of a desk.

Mounting considerations

Select a mounting location, keeping the following points in mind:

- Locate the SC-701 away from heat sources. Heat can build up inside the unit, causing damage to electrical parts.
- Locate the SC-701 away from areas prone to vibrations. The mounting location should have minimal vibrations.
- Locate the SC-701 away from areas prone to water splash and rain.
- Make sure to connect the unit's ground to the ship's ground.
- Leave sufficient space around the unit to allow access for maintenance. See the outline drawings at the back of this manual for the recommended maintenance space.
- A magnetic compass will be affected if the junction box is placed too close to the magnetic compass. Refer to the compass safe distances at the front of this manual when selecting a mounting location.
- The power switch has a small light which lights up when the unit is turned on.

Note 1: For wall/bulkhead mounted junction boxes, the cabling entrance indicated in the figure below must be oriented to face downwards, to avoid water entering the unit.

Note 2: For floor/desk mounted (top or bottom) junction boxes, select a location where water will not reach the cabling entrance indicated in the figure below.

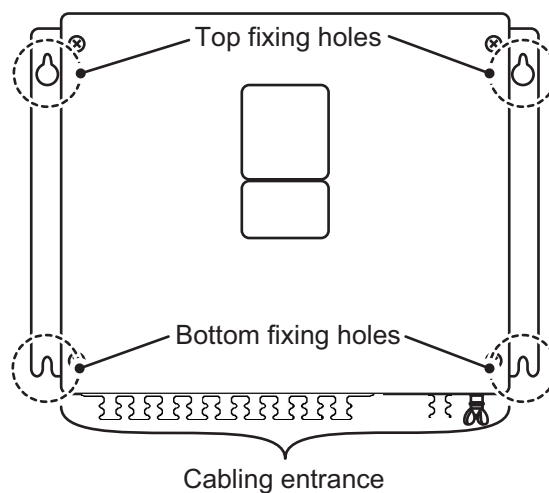

1. Referring to the outline drawing at the back of this manual, drill four pilot holes for the fixing screws.
2. Fasten two self-tapping screws ($\phi 20$, supplied) at the location for the top fixing holes. Leave approximately 5 mm of thread exposed.
3. Hang the SC-701 on the two screws using the two top fixing holes.
4. Fasten two self-tapping screws ($\phi 20$, supplied) to the bottom fixing holes.
5. Fasten all screws to secure the SC-701 in place.

1.3 How to Install the Display Unit (SC-702)

The display unit can be installed on a desktop, overhead (bulkhead) or flush mounted in a panel. Install the SC-702 on the chart table or near the helm, referring to the out-line drawing at the back of this manual.

Mounting considerations

When selecting a mounting location for the display unit, keep the following in mind:

- Keep the unit out of direct sunlight.
- The temperature and humidity should be moderate and stable.
(See the specifications at the back of this manual for operating temperatures.)
- Locate the unit away from heat sources, such as exhaust pipes and vents.
- The mounting location should be well ventilated.
- Keep the unit away from areas subject to rain or water splash.
- Install a ship-board earth to the grounding terminal at the rear of the unit.
- Mount the unit where shock and vibration are minimal.
- Keep the unit away from electromagnetic field generating equipment, such as motors and generators.
- Referring to the outline drawings at the back of this manual, leave sufficient space around the unit to allow access for maintenance.
- A magnetic compass will be affected if the unit is placed too close to it. Observe the compass safe distances listed on page ii to prevent magnetic disturbance.
- Leave enough slack in the unit's cabling to allow for maintenance and service.
- **For flush mount installations**, make sure the mounting location is flat.
- To avoid damage to the cabling when mounting the SC-702, make sure the cabling is not excessively bent.

1.3.1 How to install the SC-702 on a desktop or overhead

The display unit is shipped with the hanger, and must be removed from the hanger in order to be installed correctly.

1. Place the SC-702 on a firm, flat surface, then unfasten the two knobs on either side of the display unit to remove the unit.
2. Drill four holes for the self-tapping screws ($\phi 5 \times 20$) at the installation location.
3. Secure the hanger to the desktop or overhead bulkhead with four self-tapping screws ($\phi 5 \times 20$, included). The hanger should be oriented with the insertion slots facing forwards. For mounting dimensions and required clearance, see the outline drawing at the back of this manual.



Desktop mounted

Roof (bulkhead) mounted

4. Referring to section 1.5.6, connect the cabling to the SC-702.
5. Fit the SC-702 to the hanger and tighten the bolts on either side evenly. Adjust the angle of the SC-702 so the screen can be viewed clearly.

1.3.2 How to flush mount the SC-702

There are two methods for flush mounting the SC-702. You can mount the unit directly onto the mounting area, or use the optional front fixing panel kit.

For both flush mount installation methods, the hanger and knobs are not required. remove the unit from the hanger and discard the hanger and knobs.

Flush mounting the SC-702 (unit only)

1. Cut a hole in the mounting location, using the template at the back of this manual.
2. Drill four holes for the self-tapping screws ($\phi 5 \times 20$) at the installation location.
3. Place the SC-702 on a firm, flat surface, then unfasten the two knobs on either side of the display unit to remove the unit. The hanger can be disposed.
4. Gently lift the locking tabs at the rear of the front panel, then remove the front panel. Take care not to damage the locking tabs or the front panel.

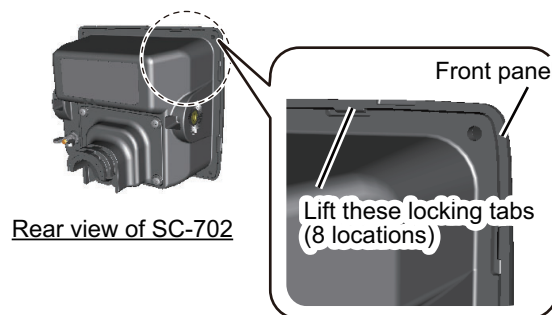

5. Fit the F Mount Cushion Kit (code: 20-032-106, included) to the rear of the SC-702 or to the mounting hole.
6. Run the cabling through the cutout, then, referring to section 1.5.6, connect the necessary cabling to the SC-702.
7. Referring to the figure below, fit the SC-702 to the cutout, then use the supplied self-tapping screws ($\phi 3 \times 20$) to secure the SC-702 to the flush mount panel.

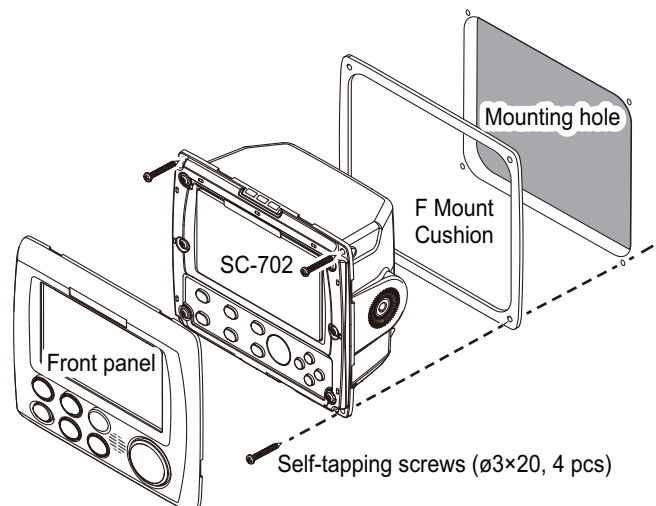

8. Re-fit the front panel that was removed at step 4.

1. INSTALLATION

Note: To remove the SC-702 from the mounting location, use the panel remover (FP19-01201, included).

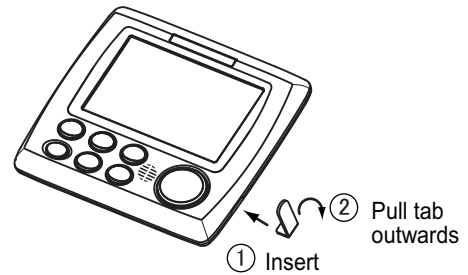

Flush mounting the SC-702 (with optional F Mount Panel)

Use the optional kit (OP24-35), referring to the outline drawings at the back of this manual and the installation instructions (C42-01310) included with the optional kit.

1.4 How to Install the Remote Display Unit (option)

The RD-50/RD-20 can be connected as a ROTI (Rate Of Turn Indicator) display unit.

For installation instructions regarding the RD-50 or RD-20, see the appropriate operator's manual (RD-50: OME-44530-x, RD20: OME-44540-x; x denotes the manual version), included with your Remote Display.

Note: If your vessel is required to be ROTI type-test compliant, use the RD-50.

1.5 Wiring

This section covers general wiring. For further details see the interconnection diagram at the back of this manual.

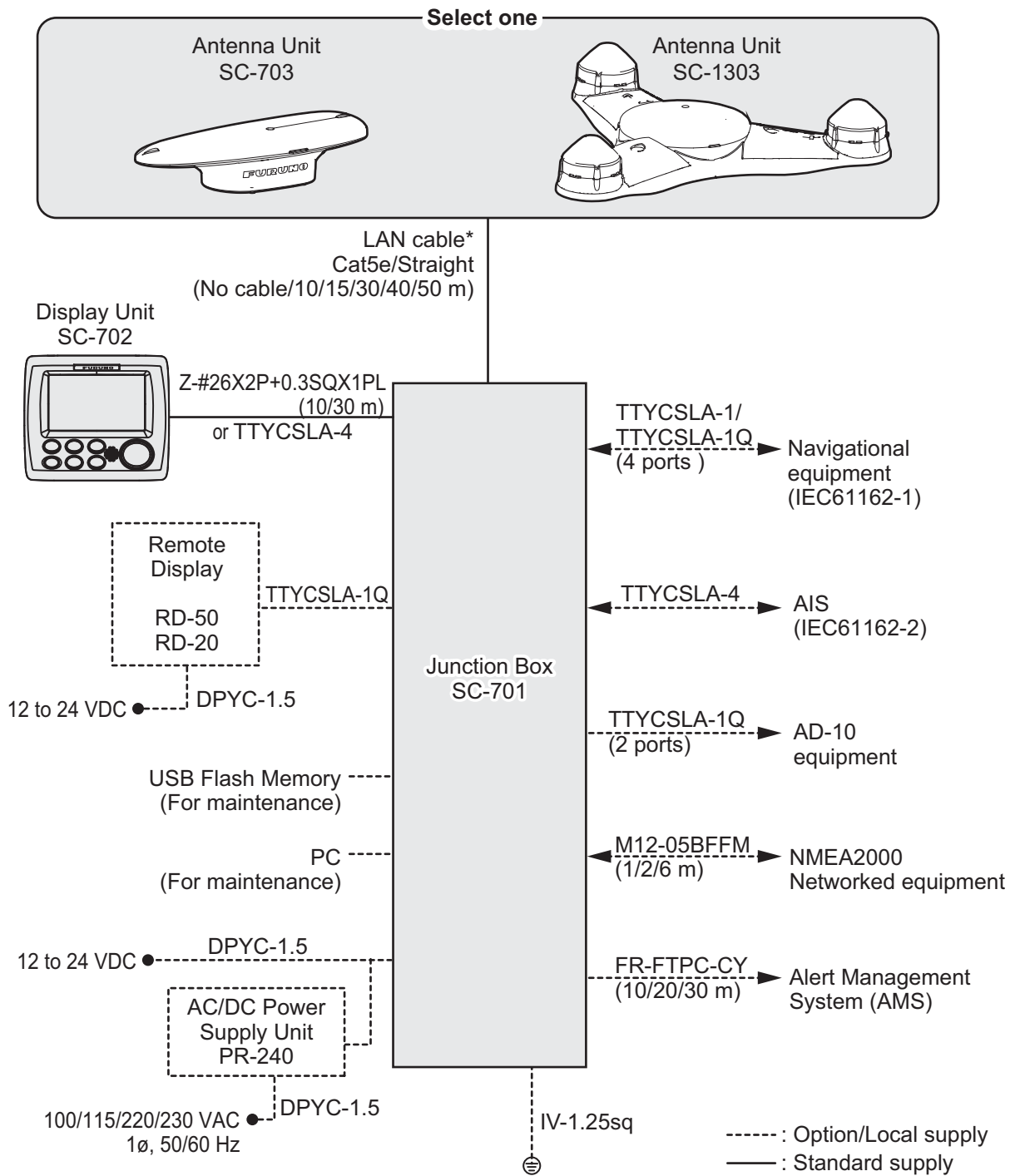

*: Attach **the supplied modular connector to the supplied LAN cable**. Do not use a commercial STP cable (LAN cable) or connector due to their low durability. See "Mounting considerations" on page 1-8 for how to attach the modular plug. Also, when using the optional LAN CONV KIT, use the existing cables.

1.5.1 How to fabricate the cables

LAN cable

Note 1: When fabricating the LAN cable for connection to the antenna unit, remove the locking nut on the antenna base, then pass **the supplied LAN cable** through the cable entrance before fitting **the supplied modular plug** on the both ends.

- Modular plug for the junction box: MPS588-C
- Modular plug for the antenna unit: FRU-RJ-PLUG-ASSY

Secure to attach the shield (folded area) of the LAN cable to the chassis of the modular plug (see the following step 6). Then fit the locking nut on the LAN cable.

Note 2: This equipment only uses straight cables.

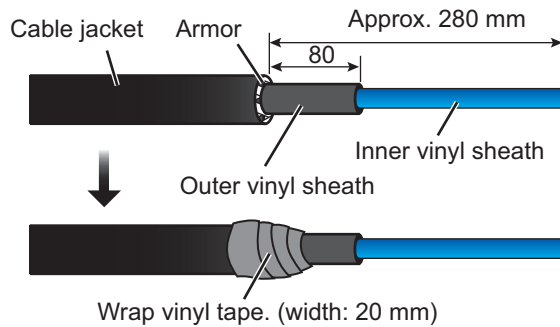

Expose the inner and outer sheaths as shown to the left.

Cover the cable jacket at the cut as shown to the left.



1 Expose inner vinyl sheath.



2 Remove the inner vinyl sheath by approx. 25 mm. Be careful not to damage inner shield and cores.

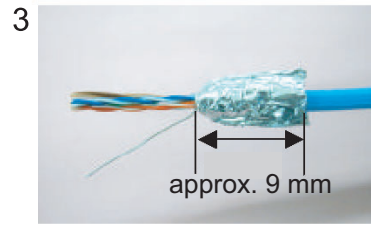

3 Fold back the shield, wrap it onto the inner vinyl sheath and cut it, leaving approx. 9 mm.

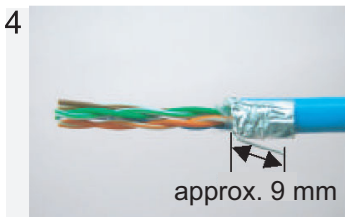

4 Fold back drain wire and cut it, leaving approx. 9 mm.

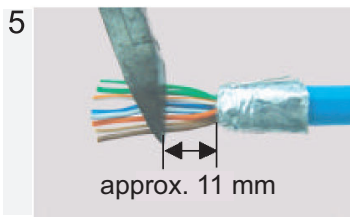

5 Straighten and flatten the cores in colored order and cut them, leaving approx. 11 mm.

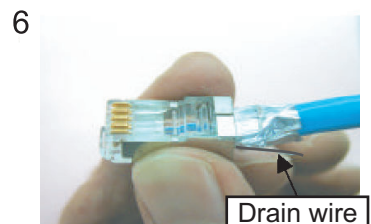

6 Insert the cable into the modular plug so that the folded part of the shield enters into the plug housing. The drain wire should be located on the tab side of the jack.



7 Using special crimping tool MPT5-8AS (PANDUIT CORP.), crimp the modular plug. Finally, check the plug visually.

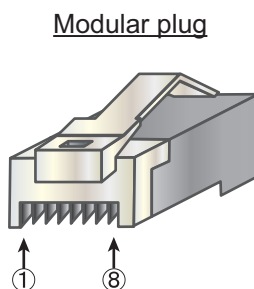

[Straight cable]

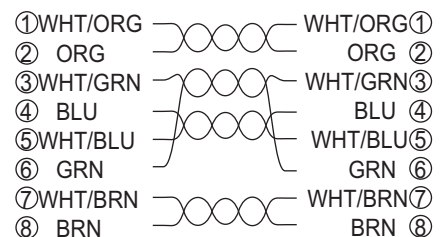

Z-#26X2P+0.3SQX1PL10/30, TTYCSLA-1/1Q/4

The supplied cable (Z-#26X2P+0.3SQX1PL10/30) does not have the armor.

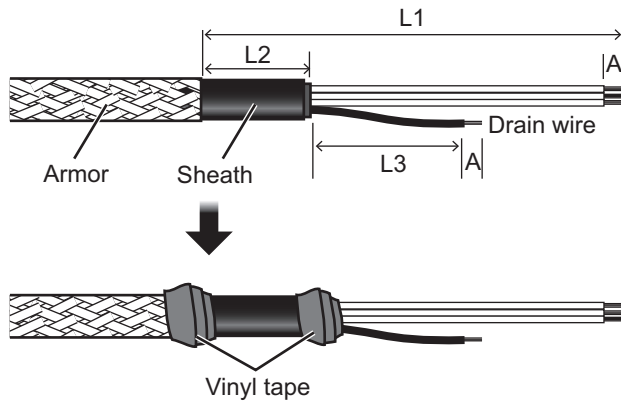

Measurements are displayed in mm

Unit	L1	L2	L3	A
Junction Box	*	80	80	6
Display Unit	130	80	50	6

*: Length depends on installation configuration. When fabricating this cable, ensure enough slack is left to allow easy access for maintenance and service.

Note: L2 lengths displayed in the table above are the minimum recommended length. Adjust the length according to the installation configuration.

Power cable DPYC-1.5

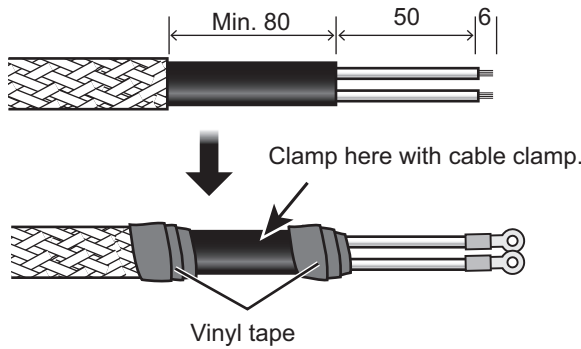

1.5.2 How to secure and waterproof the cable connections

All cable connections not inside the equipment, whether exposed to weather or otherwise, should be waterproofed and secured after making the connection.

To waterproof and secure each connection, refer to the procedure outlined below.

Securing and waterproofing connections

- 1) Wrap the connection with self-vulcanizing tape.



- 2) Wrap a second layer of self-vulcanizing tape in the opposite direction.

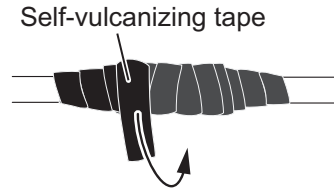

- 3) Wrap vinyl tape over the self-vulcanizing tape.

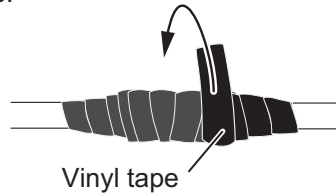

- 4) Wrap a second layer of vinyl tape in the opposite direction.

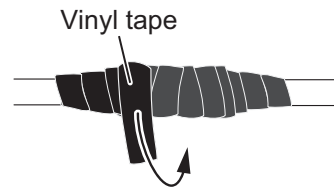

Securing and protecting unused cable connectors

- 1) Cover the loose end of the cable connector with self-vulcanizing tape.

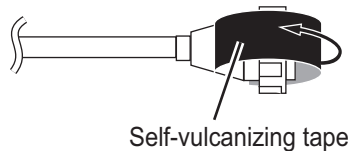

- 2) Wrap the connector with a layer of vulcanizing tape, covering approx. 50 mm of the connected cable. Confirm that the connector is covered.

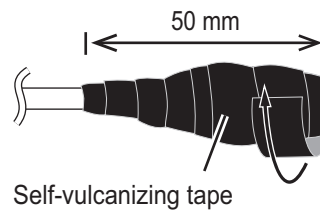

- 3) Wrap vinyl tape over the self-vulcanizing tape.



- 4) Wrap the connector with a layer of vinyl tape. Bind the tape end with a cable tie to prevent the tape from unraveling.

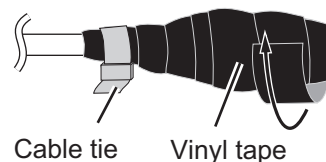

1.5.3 How to fabricate the WAGO connectors

Follow the procedure outlined below to fabricate the WAGO terminal connections.

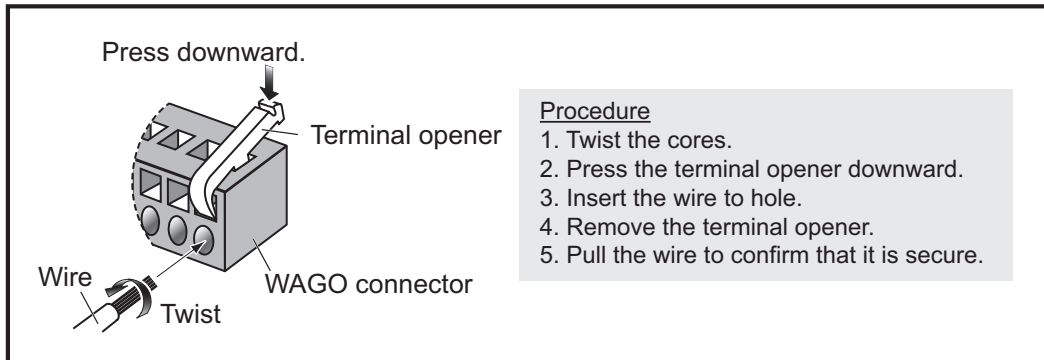

Note: Two terminal openers are included inside the SC-701. Check that the size of the opener is correct before use.

- Small opener (labeled as “DISP”): For use on connectors for cabling between the SC-702 and SC-701.
- Large opener: For use on the connectors inside the SC-701.

1.5.4 How to connect the Antenna Unit (SC-703/SC-1303)

Connect the LAN cable (included as installation materials; see table below) from the antenna LAN port to the J3 terminal inside the SC-701.

Installation materials type	LAN cable		Installation materials type	LAN cable	
	Length	Armor		Length	Armor
CP20-04300*	30 m	Yes	CP20-04500	10 m	Yes
CP20-04310*	40 m	Yes	CP20-04510	15 m	Yes
CP20-04320*	50 m	Yes	CP20-04520*	10 m	No
CP20-04340	30 m	No	CP20-04530*	15 m	No
CP20-04360*	30 m	No	CP20-04540	10 m	No
CP20-04370*	10 m	Yes	CP20-04550	15 m	No
CP20-04380*	15 m	Yes	—		

How to fit the waterproof connector

Follow the procedure below to fit the waterproof connector (included in installation materials marked with “*” in the above table).

Waterproof connector components

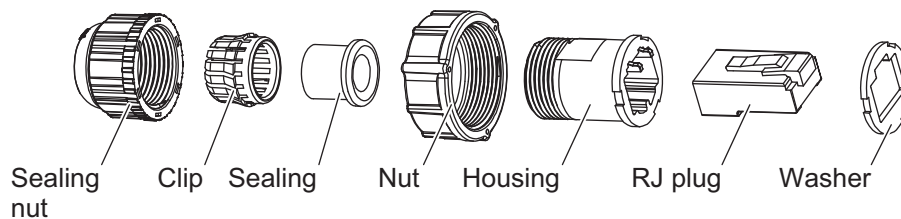

1. INSTALLATION

1. Referring to the figure below, fit the connector components to the LAN cable. Strip approximately 10 mm of the outer sheath to expose the cores, then fold the drain wire back, along the cable.

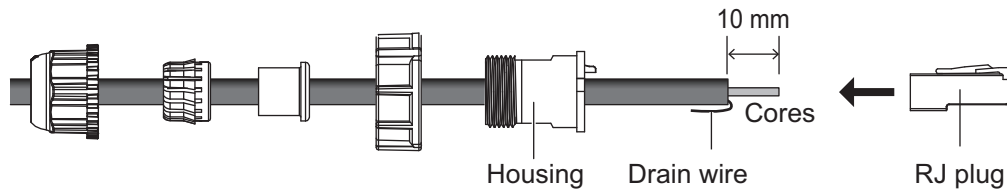

2. Insert the cable cores into the RJ plug, then secure the cores using a crimping tool (MPT5-8AS, or equivalent, local supply). Make sure the RJ plug is in contact with the drain wire.
3. Push the RJ plug into the housing. Make sure the RJ plug is aligned with the housing guides, then fit the nut, sealing, clip and sealing nut, in order.

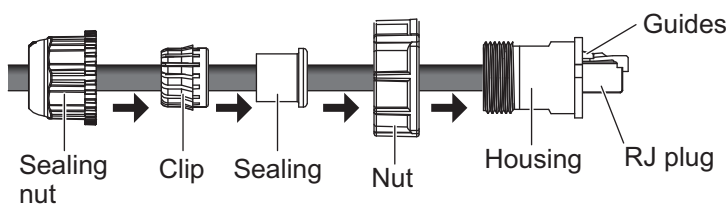

4. Fasten the sealing nut until the thread on the housing is not visible. Fastening torque: 0.72 to 0.98 N•m.

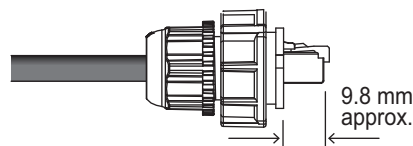

5. Fit the washer to the RJ connector, making sure that the indents on the washer match the indents on the connector.



6. Connect the assembled waterproof connector to the LAN cable on the antenna.
7. Use self-vulcanizing tape and vinyl tape to additionally waterproof the connection. For details on waterproofing cable connections, see section 1.5.2.

Retrofits - Coaxial cable connection

You can use the existing coaxial cable for connection. In this case, the optional LAN_CNV kits (OP20-47 and OP20-48) are required.

Cable connection:

For cable connection, use one of the three existing coaxial cables. Connect both ends of the cable, one end to the antenna unit, the other end to the junction box. Secure and protect the connection points of the coaxial cables, referring to subsection 1.5.2.

For unused existing coaxial cables, secure and protect both ends of the coaxial cables, referring to subsection 1.5.2.

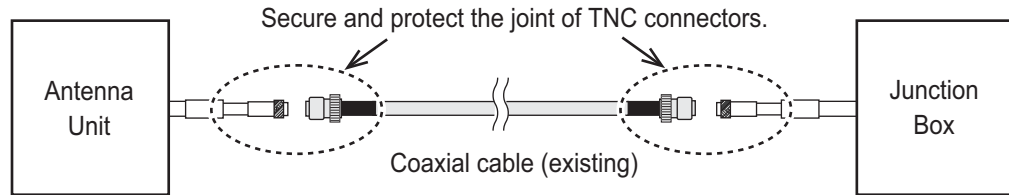

1.5.5 How to connect the Junction Box (SC-701)

The Junction Box (SC-701) has two rows of cable entrances for connection. The following figure and table show the internal connection points for the SC-701 and the recommended cable entrance for each connection (based on a configuration which uses all connections). The tables on the following pages show the pin connections for each WAGO connector.

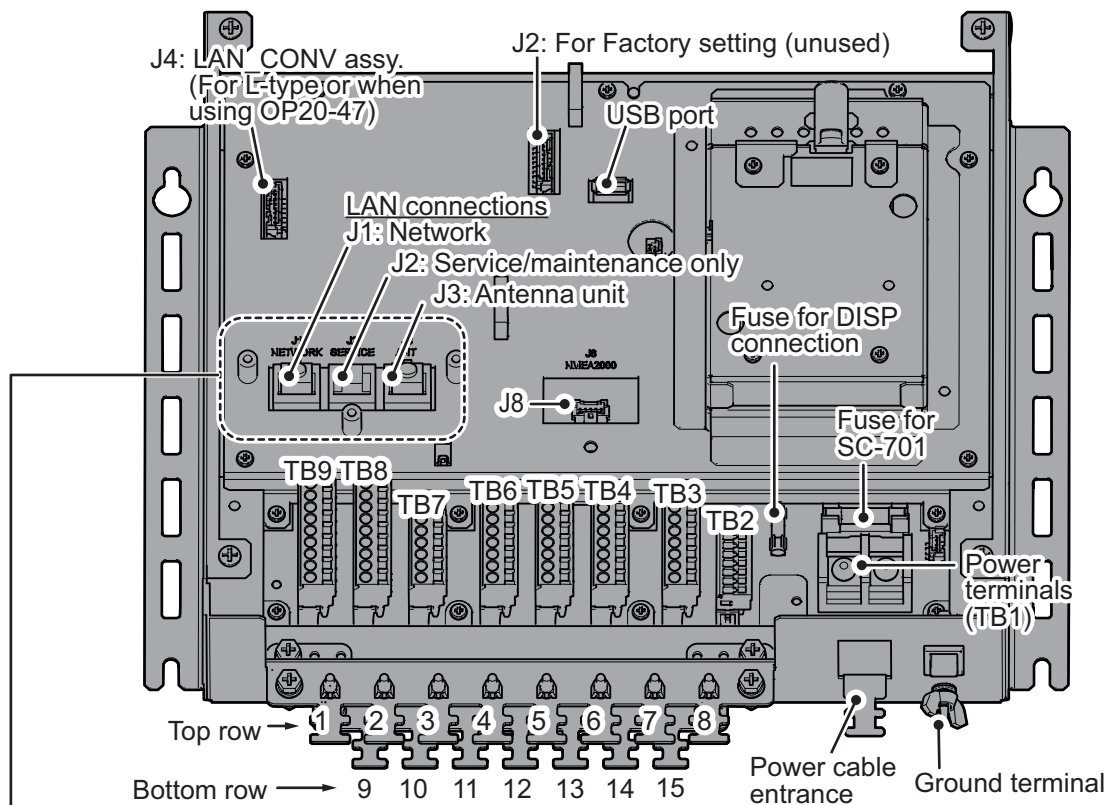

How to secure the LAN connectors

The securing plate is pre-attached to the LAN port. Detach the securing plate to connect the LAN cables, then reattach the plate after connecting the LAN cables.

The securing plate prevents communication error between the Junction Box and the Antenna Unit that is caused by the vibration. Be sure to attach the securing plate after connecting the LAN cables.

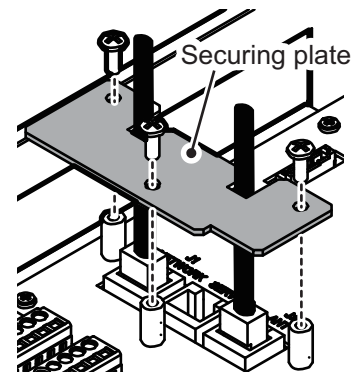

Note 1: LAN cable recommended entrances should be used to prevent undue stress to the LAN cables. The power and DISP cable must be passed through their recommended entrance to prevent damaged to the cabling.

1. INSTALLATION

Note 2: Cable entrances 1 through 8 are protected from foreign materials with a small plastic spacer. To use one these cable entrances, remove the spacer, then pass the cable through.

The following table indicates the recommended cable entrance, connector number and the cable type required for connections to the SC-701.

External connection	Recommended entrance	Connector No.	Cable type
Power	Power cable entrance only	TB1	(JIS) DPYC-1.5
Shipboard network (AMS, etc.) (IEC61162-450)	1, 2 or 9	J1	(JIS) FR-FTPC-CY
Antenna unit (SC-703 or SC-1303)	9	J3	LAN
	10 or 11	LAN-Coaxial conversion kit	Existing coaxial.
AD-10 format data output	3 or 10	TB8 or TB9	(JIS) TTYCSLA-1Q
NMEA0183 (IEC61162-2)	3 or 10	TB7	(JIS) TTYCSLA-4
NMEA0183 (IEC61161-1)	4, 5, 6, 7 or 11, 12, 13, 14	TB3 to TB6	(JIS) TTYCSLA-1 or TTYCSLA-1Q
Display unit (SC-702)	15 only	TB2	(JIS) TTYCSLA-4
NMEA2000	4, 5, 6, 7 or 11, 12, 13, 14	J8	FRU-NMEA-PMM-02
USB Flash Memory*	-	USB port	-

*: To remove the USB Flash Memory, see "How to remove the USB Flash Memory" on page 4-4.

Note: For (JIS) cable equivalents, see the JIS cable guide at the back of this manual.

TB2 WAGO connector (9-pin, TTYCSLA-4)

Pin no.	Connection (signal)	Description	Remarks
1	P12V	Power	-
2	GND	Grounding.	-
3			-
4			-
5	TD6_A	TX data	Fixed at 115200 bps.
6	TD6_B	TX data	
7	RD6_A	RX data	
8	RD6_B	RX data	
9	GND	Drain wire	Connect to drain wire.

TB3 to TB6 WAGO connectors (7-pin, TTYCSLA-1/TTYCSLA-1Q)

Pin no.	Connection (signal)	Description	Remarks
1	TDx_1A	TX data	NMEA(Ver1.5/2.0/3.0/4.0), IEC61162-1 "x" denotes the connection to terminals as shown below.
2	TDx_1B	TX data	
3	TDx_2A	TX data	
4	TDx_2B	TX data	
5	RDx_H	RX data (Hot)	
6	RDx_C	RX data (Cold)	
7	GND	Drain wire	

Signal	Terminal
TR/RD5	TB3
TR/RD4	TB4
TR/RD3	TB5
TR/RD2	TB6

TB7 WAGO connector (6-pin, TTYCSLA-4)

Pin no.	Connection (signal)	Description	Remarks
1	TD1_A	TX data	NMEA(Ver1.5/2.0/3.0/4.0) IEC61162-2
2	TD1_B	TX data	
3	RD1_A	RX data	
4	RD1_B	RX data	
5	ISO_GND	Isolating ground	
6	GND	Drain wire	

TB8 WAGO connector (9-pin, TTYCSLA-1Q)

Pin no.	Connection (signal)	Description	Remarks
1	DATA_3A	RS-485	Data output in AD-10 format.
2	DATA_3B		
3	SHIFT_3A		Shift output in AD-10 format.
4	SHIFT_3B		
5	DATA_4A		Data output in AD-10 format.
6	DATA_4B		
7	SHIFT_4A		Shift output in AD-10 format.
8	SHIFT_4B		
9	GND		

TB9 WAGO connector (9-pin, TTYCSLA-1Q)

Pin no.	Connection (signal)	Description	Remarks
1	DATA_1A	RS-485	Data output in AD-10 format.
2	DATA_1B		
3	SHIFT_1A		Shift output in AD-10 format.
4	SHIFT_1B		
5	DATA_2A		Data output in AD-10 format.
6	DATA_2B		
7	SHIFT_2A		Shift output in AD-10 format.
8	SHIFT_2B		
9	GND		

J8 PA connector (5-pin, FRU-NMEA-PMM-02)

Pin no.	Connection (signal)	Description	Remarks
1	Shield	CAN_Shield	
2	NET_S	Power input	+9 V DC to +16 V DC
3	NET_C	CAN_GND	
4	NET_H	NMEA2000	Data I/O (Hot)
5	NET_L	NMEA2000	Data I/O (Cold)

1.5.6 How to connect the Display unit (SC-702)

The display unit is connected to the Junction Box using a 9-pin WAGO connector. Referring to section 1.5.3 and the table below, fabricate the WAGO connector. Note that the WAGO connector is included inside the SC-702 and must first be removed from the unit.

1. Unfasten the four screws on the rear cable clamp of the SC-702, then remove the cable clamp to reveal the WAGO connector.
2. Unplug the WAGO connector from the SC-702.
3. Pass the cable through the cable clamp.

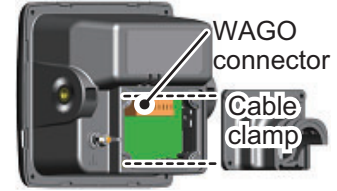

For the supplied cable (Z-#26X2P+0.3SQX1PL)

When the supplied cable is used, the supplied cable gasket (Type: 20-037-2104-0) must be attached. Open the cut line of the cable gasket then attach the cable gasket to the cable.

Note: To prevent water intrusion, the cut line of the cable gasket must face downward.

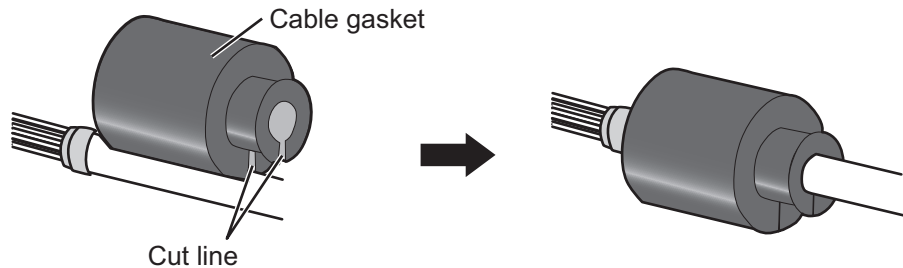

4. Referring to the following table and the interconnection diagram at the back of this manual, connect the cable to the WAGO connector.

Display unit (SC-702) internal J301 WAGO connector (9-pin, TTYCSLA-4)

Pin no.	Connection (signal)	Description	Remarks
1	P12V	Power	-
2	GND	Grounding. Connect to SC-701.	-
3			-
4			-
5	TD_A	TX data	Fixed at 115200 bps.
6	TD_B	TX data	
7	RD_A	RX data	
8	RD_B	RX data	
9	GND	Drain wire	Connect to drain wire.

5. Connect the cabling to the SC-702.
6. Slide the clamp along the cable towards the SC-702, then fasten the four screws which were removed at step 1.

7. Secure the cable to the cable clamp, referring to the figure below.

Top view of cable clamp

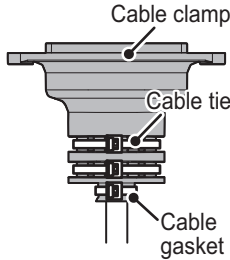
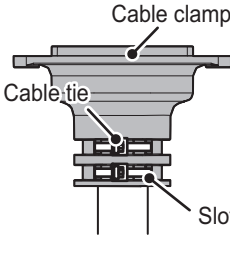
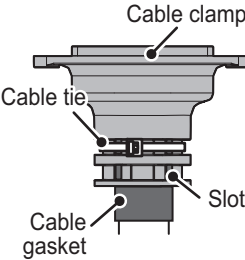
Supplied cable (Z-#26X2P+0.3SQX1PL)	Equivalent cable for JIS cable (TTYCSLA-4)	
	Without Water Proof Kit	With Water Proof Kit
With three cable ties	With two cable ties	With a single cable tie
 <p>Secure the cable gasket also with a cable tie.</p>	 <p>Wind cable ties through the slots.</p>	 <p>Wind a cable tie outside of the cable clamp.</p>

1

Note: In cases where the WAGO connector is connected to the cable before the cable is passed through the cable clamp, the cable clamp can be adjusted to allow connection. Adjusting the cable clamp as outlined in the figure below voids the IPx5 water-proof rating of the clamp and the unit.

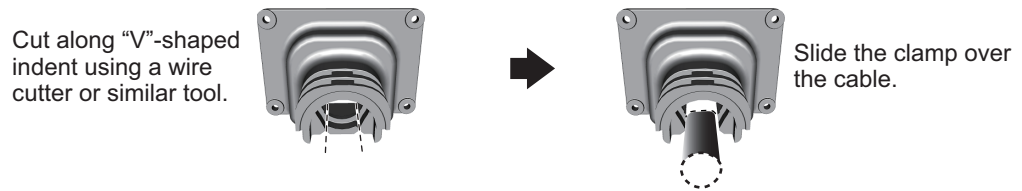

To keep the IPx5 rating, remove the WAGO connector, then repeat the procedure above.

1. INSTALLATION

How to fit the optional waterproofing kit (OP05-139)

The optional waterproofing kit must be fitted at the same time as the cabling is connected to the SC-702.

Note: To satisfy the requirements for IPX5 waterproof rating, the cable used must have a diameter of 14.4 mm (± 0.4 mm).

1. Unfasten the four screws on the rear cable clamp, then remove the cable clamp to reveal the WAGO connector.
2. Fit the cable gasket to the cable clamp, referring to the figure below.
 1. Fit the cable gasket to the cable clamp, passing the fixing lip partially through the cable clamp.
 2. To pass the fixing lip completely through the cable gasket, twist the cable gasket gently.

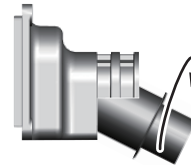
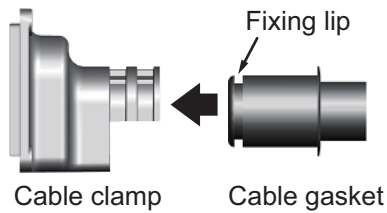

3. Check that the cable gasket is flush against the cable clamp, as shown below.

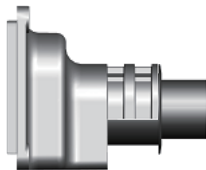

4. Check that the cable gasket's fixing lip is flush against the inside of the cable clamp.

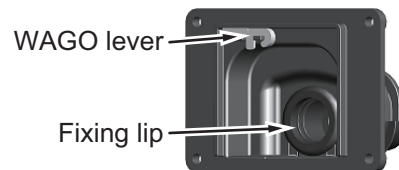

3. Pass the cabling through the cable gasket and cable clamp.
4. Fit the cover gasket (rubber seal) to the rear of the SC-702. Make sure the rubber seal is placed inside the groove indicated in the figure below.

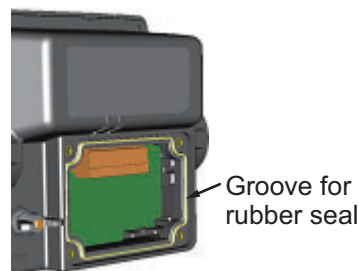

5. Connect the cabling to the SC-702, referring to section 1.5.6.
6. Slide the cable clamp along the cable until the clamp is flush against the rear of the SC-702.

Note: The cable clamp must be oriented with the dome facing upwards in order to retain its waterproofing rating.
7. Fasten the four screws removed at step 1.
8. Secure the cables to the cable clamp with cable ties.

1.5.7 How to connect the Remote Display Unit (option)

Connect the RD-50 to the SC-70/SC-130 referring to the connection diagram below.

RD-50 connection

(For details, see the RD-50 Operator's Manual OME-44530)

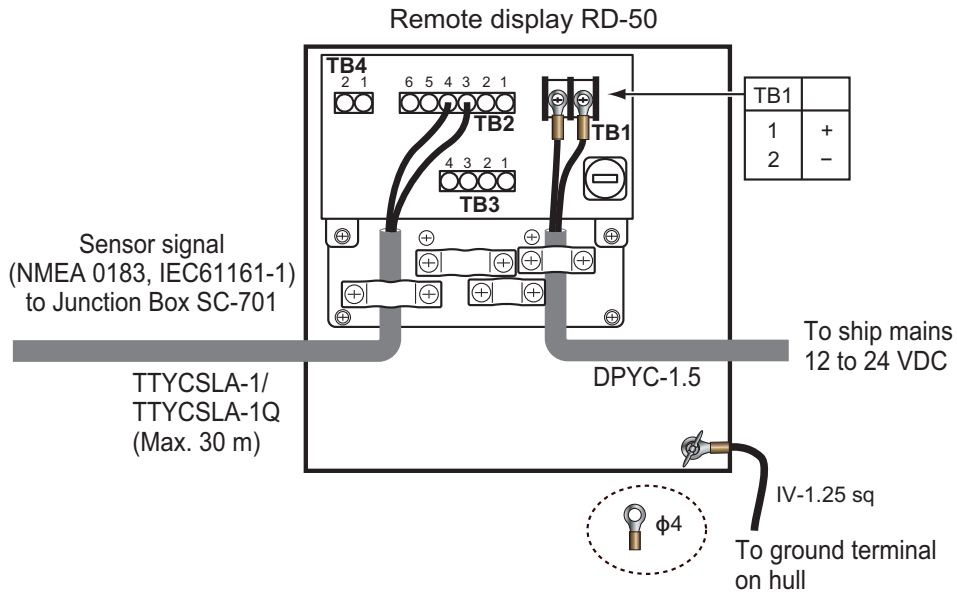

RD-20 Connection

(For details, see the RD-20 Operator's Manual OME-44540)

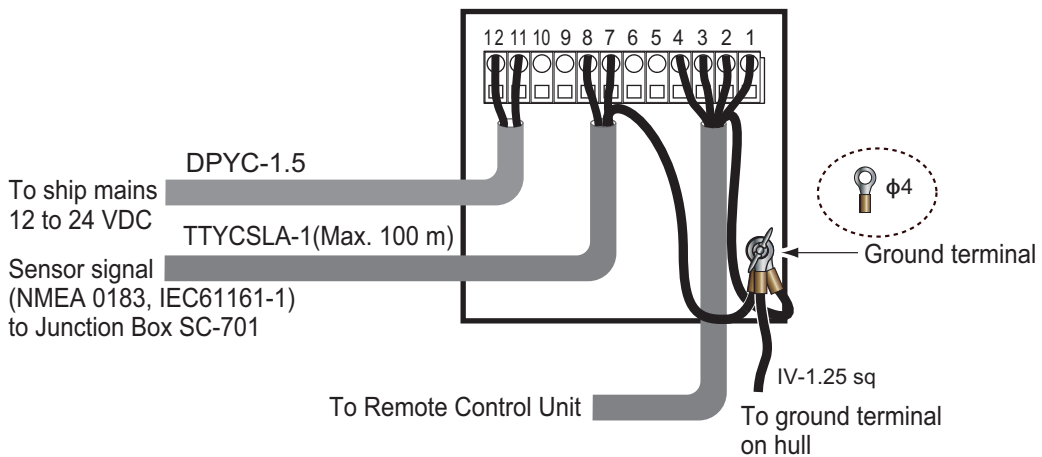

1.6 Initial Settings

The initial setup for your SC-70/SC-130 requires the system to be powered. Referring to the instructions at section 2.2, turn the power on.

For the sake of brevity, the following terminology is used.

Terminology	Meaning
"Select"	Example: "Select [SENSOR], then press the ENT key." Use the Cursorpad to select the menu item.
"Open the [MENU]."	Press the MENU ESC key; this opens the [MENU].
"Close the [MENU]."	<ul style="list-style-type: none"> • Press the MENU ESC key; this closes the [MENU] and returns to the last used display screen or sub-screen. • Press the DISP key; this closes the [MENU] and returns to the main screen.
IMO type	SC-70 or SC-130 systems which have been assigned as [MERCHANT] at installation and installed on vessels which meet the applicable IMO standards.
Non-IMO type	SC-70 or SC-130 systems which have been assigned as [FISHING] at installation and installed on vessels which do not meet the applicable IMO standards.
INTERNATIONAL	[TYPE APPROVAL] setting for international vessels other than Russia.
RUSSIA	[TYPE APPROVAL] setting for Russian vessels.

When the unit is powered for the first time, it is in a "cold start" state. There is no satellite data (almanac data) stored. In this state, the unit searches for, and stores, satellites to find its heading. This process takes approximately 90 seconds. If the heading is not found within 30 minutes, the antenna installation location may not be suitable. A lack of visible satellites (less than five) can also prevent the unit from finding a heading. Resolve the problem, then re-check the tracking status.

If the heading error is between 5° and 10°, adjust the antenna unit orientation while monitoring the heading indication on the SC-702.

Once a heading has been found, the following items may need setting or adjustment:

- Vessel dimensions.
- Antenna location.
- Offset heading, roll, pitch, heave, etc.
- Main device mode.
- Key code (as necessary).
- Alert mode.
- Legacy sentence input.
- I/O menu settings as appropriate. (See section 1.8.)

Note: Some settings are set at installation and are non-selectable (gray in color) from the menu. These settings require key code input. Key code input is not covered in the setting procedures for these items. To adjust these settings, contact your dealer.

1.6.1 Main menu

How to access the menu

The menu is locked with a key code. Press the **MENU ESC** key to show the key code input window (shown below-right).

If this is the first time the unit has been turned on, the key code is not set at default. Press the **ENT** key to access the menu. It is recommended to set a new key code in this case.

If the unit has a previously set key code, input the key code, then press the **ENT** key to access the menu.



1

Note 1: Key code input is required to access the menu each time the unit is turned off, then on again.

Note 2: The menu closes automatically if no keys are pressed within one minute.

How to change/set the key code

1. Open the [MENU].
2. Select [SYSTEM], then press the **ENT** key.
3. Select [KEY CODE], then press the **ENT** key.
4. Select [CHANGE], then press the **ENT** key. An input window appears.

The currently selected input box is indicated with a small arrow to the left-side of the input box, as shown in the figure to the right.

To set the key code for the first time, press the **ENT** key to select the [NEW KEY CODE] input box, then skip to step 6.

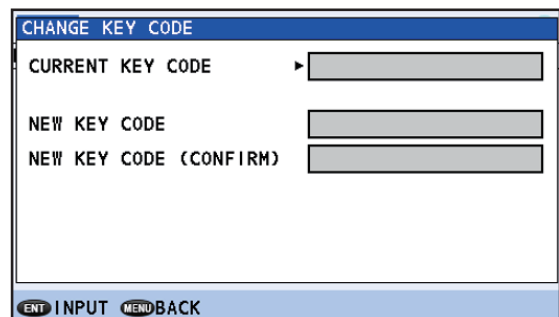

5. Enter the current user key code. If the key code is incorrect, the input window is reset to blank. If the key code is correct, the arrow indication moves to the [NEW KEY CODE] input box.
6. Enter a new key code, then press the **ENT** key. The arrow indication moves to the [NEW KEY CODE (CONFIRM)] input box.
7. Enter the new key code again, then press the **ENT** key. If the key codes match, the [CHANGE KEY CODE] input window disappears. If the key codes do not match, the input boxes for [NEW KEY CODE] and [NEW KEY CODE (CONFIRM)] are reset and the arrow indication returns to the [NEW KEY CODE] box. Repeat the procedure from step 6.
8. Close the [MENU].

How to disable access to the menu

Where necessary, you can disable menu access by doing the following:

1. Open the [MENU].
2. Select [SYSTEM], then press the **ENT** key.
3. Select [KEY CODE], then press the **ENT** key.
4. Select [LOGOUT], then press the **ENT** key. The menu closes.

1.6.2 How to set vessel dimensions, antenna location and CCRP

Note: Access to the [OFFSET] menu requires the [SERVICE] menu to be unlocked. To unlock the service menu, consult your local dealer.

1. Open the [MENU].
2. Select [SENSOR], then press the **ENT** key.
3. Select [OFFSET], press the **ENT** key.
4. Select [DIMENSIONS/CCRP], then press the **ENT** key. The settings window appears. The figure below is an example of the settings window.

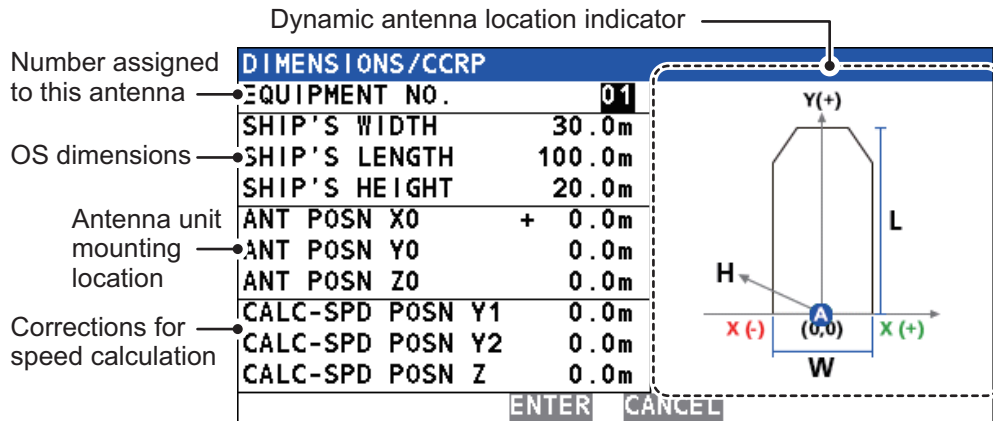

5. Select [EQUIPMENT NO.], then press the **ENT** key. The [INPUT EQUIPMENT NO.] pop up window appears.
6. Set the antenna number you wish to set the location for.
7. Select [ENTER], at the bottom of the pop up window, then press the **ENT** key. The antenna selected here is used to output the POS sentence to external equipment.
8. Select [SHIP'S WIDTH], then press the **ENT** key. A numerical pop up window appears. Referring to the figure above, set the dimensions of the vessel.
9. Set [SHIP'S LENGTH] and [SHIP'S HEIGHT] in a similar manner.

Note: [SHIP'S HEIGHT] is from the keel to the mast top.
10. Referring to the table below, set the antenna mounting position (CCRP) and the speed calculation adjustments.

Note: These settings require CCRP and ship dimensions. Do step 5 and step 6 before changing these settings.

Indication	Description	Setting range
[ANT POSN X0]	Port-starboard location of antenna unit. Enter a negative value for port-side, positive value for starboard-side. The center of the vessel is [0 m].	- ([SHIP'S WIDTH]/2) to + ([SHIP'S WIDTH]/2). For example, if the [SHIP'S WIDTH] is set to [100 m], the range is [-50 m] to [+50 m].
[ANT POSN Y0]	Bow-stern location of the antenna unit. Calculated from the center of the stern.	[0.0 m] to [SHIP'S LENGTH]. For example, if [SHIP'S LENGTH] is set to [45 m], the maximum range for this setting is also [45 m].
[ANT POSN Z0]	Height of antenna unit location, from the bottom of the ship.	[0.0 m] to [99.9 m]
[CALC-SPD POSN Y1]*	Set the bow-stern position for calculating the 3-axis speed. Ship's speed can be measured at two locations in addition to the antenna position. Enter the backward distance from the reference position (Fwd Center of the bow) to the position where you want to measure the ship's speed. Normally, keep the default settings. Note: The value for [CALC-SPD-Y1] is set to 0 m as default. [CALC-SPD-Y2] is automatically set to the ship's length (set previously, in the same menu). For most vessels, these two settings do not require adjustment. On large vessels, where speed and location is required at numerous points for situations such as docking, these two values should be adjusted as required. For all vessels, [CALC-SPD-Z] should be set to the vessel's draft value. For further information, contact your local FURUNO dealer.	[0.0 m] to [SHIP'S LENGTH]. For example, if [SHIP'S LENGTH] is set to [45 m], the maximum range for this setting is also [45 m].
[CALC-SPD POSN Y2]*	Set the bow-stern position for calculating the 3-axis speed. Ship's speed can be measured at two locations in addition to the antenna position. Enter the backward distance from the reference position (Fwd Center of the bow) to the position where you want to measure the ship's speed. Normally, keep the default settings. Note: The value for [CALC-SPD-Y1] is set to 0 m as default. [CALC-SPD-Y2] is automatically set to the ship's length (set previously, in the same menu). For most vessels, these two settings do not require adjustment. On large vessels, where speed and location is required at numerous points for situations such as docking, these two values should be adjusted as required. For all vessels, [CALC-SPD-Z] should be set to the vessel's draft value. For further information, contact your local FURUNO dealer.	[0.0 m] to [SHIP'S LENGTH]. For example, if [SHIP'S LENGTH] is set to [45 m], the maximum range for this setting is also [45 m].
[CALC-SPD POSN Z]*	Set the height for calculating the 3-axis speed. Enter the distance from the bottom of the ship to the position where you want to measure the ship's speed. For example, enter the draft value when you want to measure the speed at draft position.	[0.0 m] to [ANT POS Z0].

*: These settings are required in order to display correct data on the SPD display. See section 2.10.

11. To apply the settings, select [ENTER], then press the **ENT** key.
To discard the changes and start again, select [CANCEL], then press the **ENT** key.
12. Close the [MENU].

1.6.3 How to apply offsets for heading/pitch/heave/roll/position

Note: Access to the [OFFSET] menu requires the [SERVICE] menu to be unlocked. To unlock the service menu, consult your local dealer.

1. Open the [MENU].
2. Select [SENSOR], then press the **ENT** key.
3. Select [OFFSET], then press the **ENT** key.
4. Referring to the table below, select the appropriate item to offset, then press the **ENT** key.

Menu item	Description	Offset range
HDG OFFSET	Offset the heading.	-180° to +180°
PITCH OFFSET	Offset to compensate for pitch.	-10°000 to +10°000
ROLL OFFSET	Offset to compensate for roll.	
POSITION OFFSET	Offset the Own Ship position.	North/South: 00.0000' to 59.9999' East/West: 00.0000' to 59.9999'
DIMENSIONS/CCRP	Set the ship size, location of the antenna and CCRP.	See section 1.6.2.
SOG OFFSET	Offset the SOG.	-12.5% to +12.5%
ATM OFFSET	Offset atmospheric pressure.	-99.9 hPa to +99.9 hPa
TEMP OFFSET	Offset the temperature. Note: The displayed temperature appears lower than the actual temperature immediately after the power is turned on. It takes approximately one hour for the equipment to display the correct temperature in a stable manner.	-99.9°C to +99.9°C

5. Use the arrows key to set the offset, then press the **ENT** key.
6. Close the [MENU].

1.6.4 How to set the heave output delay

To use the heaving compensation on external equipment, the SC-70/SC-130 must output the heave data to the external equipment. Do as follows to output heave data.

Note: Access to the [HEAVE OUTPUT DELAY] menu requires the [SERVICE] menu to be unlocked. To unlock the service menu, consult your local dealer.

1. Open the [MENU].
2. Select [SERVICE], then press the **ENT** key.

SERVICE	
1	EDIT : UNLOCK
2	ALERT MODE : ALERT IF2
3	CHANGE MODE ▶
4	PARTS REPLACEMENT ▶
5	UPDATES ▶
6	MISCELLANEOUS ▶
7	HEAVE OUTPUT DELAY : OFF

3. Select [HEAVE OUTPUT DELAY], then press the **ENT** key.
4. Select [ON] or [OFF] as appropriate, then press the **ENT** key.
To output the heave data to the external equipment, select [ON].
5. When [ON] is selected, confirm that the delay time setting is "050 ms", then select [ENTER]. When [OFF] is selected, go to the next step.
Keep the default delay time setting (50 ms).

ON
OFF

INPUT DELAY TIME
▲ 050ms ▼
ENTER CANCEL

1

When you change the setting for [HEAVE OUTPUT DELAY], the following confirmation message appears.

THIS CHANGE REQUIRES RESTART.
ARE YOU SURE?
YES NO

6. Select [YES], then press the **ENT** key.
The following message appears and the system is restarted automatically.

PLEASE WAIT FOR RESTART.

1.7 How to Access and Use the [SERVICE] Menu

Menu items which require service level access are shown in gray. A key code, obtained from FURUNO, is required to access the [SERVICE] menu. Several initial settings must be done from this menu to complete the setup of your SC-70 or SC-130. To adjust or change any of these settings, consult your local dealer.

1.8 I/O Menu Settings

To set which data to output to external equipment from the SC-70/ SC-130, see section 2.15.

1.9 Initial Settings for the Remote Display

After wiring is complete for all units in the configuration, setup the [ROTI Display] as follows. The RD-50 requires menu setup.

For detailed operational guidance for either Remote Display unit, see the appropriate Operator's Manual (RD-50: OME-44530-x, RD-20: OME-44540-x: "x" denotes version).

How to setup the RD-50 for ROTI display.

1. Open the [SERVICE] menu for the RD-50.

UNIT Name	: RD-50
Serial No	: 6408-XXXX
PWB No	: 26P0006-XX
Remote Dimmer	: Main
Depth Select	: Auto
Depth Position	: Single
L/L Digit	: 4digit
Without Checksum	: Disable
I/O Port	
Port1	: 4800
SIO Monitor	
Sensor Out	: ON
Device Mode	: Normal
LCD RESET	
SIM	: OFF
Service RESET	
[▲]/[▼] : Select	
[ENT] : Enter	

XXXX: Serial number
XX: Program version number

2. Select [Device Mode], then press the **ENT** key.
Note: Do not change the settings for any other items in the [SYSTEM] menu for the RD-50.
3. Select [ROTI], then press the **ENT** key.
4. Press the **PWR** key to close the menu and turn off the power. When the power is next turned on, your RD-50 shows the [ROTI Display] from the SC-70/SC-130.

How to setup the RD-20 for ROTI display

Press the **DISP** key on the RD-20 to show the ROTI display.

2. OPERATION

2.1 Controls Overview



No.	Key	Description
1	BRILL	<ul style="list-style-type: none"> • Opens the [BRILL SETTING] window. • With the BRILL SETTING window open, adjusts the screen brilliance.
2	DISP	<ul style="list-style-type: none"> • <u>With the menu open:</u> Close the menu and return to the last used display mode's main screen. • <u>Without the menu open:</u> Change the display mode.
3	MENU ESC	<p><u>Short press:</u></p> <ul style="list-style-type: none"> • Open the main menu. • Close the menu and return to the last used screen. • Close settings pop up window and return to the last used menu. <p><u>Long press:</u></p> <ul style="list-style-type: none"> • Opens the [ALERT LIST].
4	ACK	<ul style="list-style-type: none"> • Acknowledge an individual alert and close the alert pop up message.
5	LIST	<ul style="list-style-type: none"> • Show the [LIST] display. • Cycle through the [LIST] display.
6	ENT	<ul style="list-style-type: none"> • Open a menu item. • Confirm selected setting in pop up window. • Switch between graphic and main display for the current device mode. • From the SPD main screen: Long press to reset track (for non-IMO types only).
7	Cursorpad	<ul style="list-style-type: none"> • Navigate menus. <ul style="list-style-type: none"> ◀ button: Go back one layer in the menu. ▶ button: Open the selected menu item. ▲ button: Move selection cursor to the item above the current selection. ▼ button: Move selection cursor to the item below the current selection. • Adjust settings. <ul style="list-style-type: none"> ◀ button: Move cursor to the left. ▶ button: Move cursor to the right. ▲ button: Increase the value of the selected item. ▼ button: Decrease the value of the selected item. • With [INTEGRITY] screen shown: scroll through the displayed data when more than one screen is available.

2.2 How to Turn the Power On/Off

The power is turned on or off from the Junction Box (SC-701). Turn the SC-701 on/off to turn the SC-702 on/off.

The startup screen appears for five seconds, then the system starts a diagnostic test. The diagnostic test takes approximately 30 seconds to complete. After the diagnostic test is complete, the main screen appears. You can also bypass the diagnostic test and show the main screen at any time during the test, by pressing any key.

Note 1: If the startup process has one or more errors, the message "COMMUNICATION ERROR" appears at the bottom of the diagnostic test screen.

Note 2: The display may appear "sluggish" if the ambient temperature is low.

Note 3: Viewable angles may vary between daylight and nighttime.



Startup/initialize screen.
Shown for approximately five seconds.

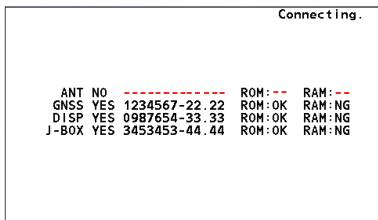

Self-test screen.
Shown for approximately 30 seconds.

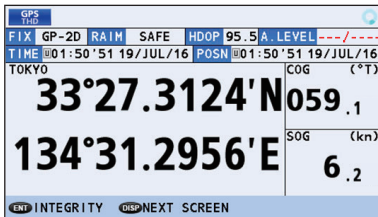

Main screen.

For IMO type vessels: The preset [DEVICE MODE]* screen appears.
For non-IMO vessels: The last used screen appears.

*: The [DEVICE MODE] is set at installation.
To change this setting, consult your local dealer.

2.3 How to Adjust the Brilliance, Change the Background Color

The display unit (SC-702) has brilliance (brightness) controls for the screen and the key panel.

2.3.1 How to adjust the screen and key panel brilliance

To change the brilliance, do the following:

1. Press the **BRILL** key. The brilliance pop up window appears.

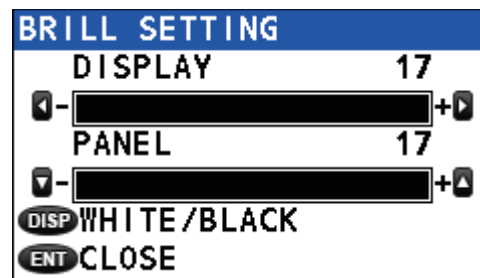

Note: The pop up window automatically disappears if there is no operation detected.

2. Press ◀ to reduce, or ▶ to increase, the display brilliance.
3. Press ▼ to reduce, or ▲ to increase, the key panel brilliance.
4. Press the **ENT** key to close the pop up window.

The factory default settings and setting range for brilliance are listed in the table below.

Display	Panel
Setting range: [1] to [17]	Setting Range: [0] to [17]
White background default: [14]	White background default: [10]
Black background default: [6]	Black background default: [10]

Note: The brilliance default setting for RD-50/RD-20 is [9], and the setting range is [0] to [9]. See the operator's manual (RD-50: OME-44530-x, RD:20: OME-44540-x; "x" denotes version) for details.

2.3.2 How to change the background and text color

1. Press the **BRILL** key to show the brilliance pop up window.
2. Press the **DISP** key to alternate background/text color.

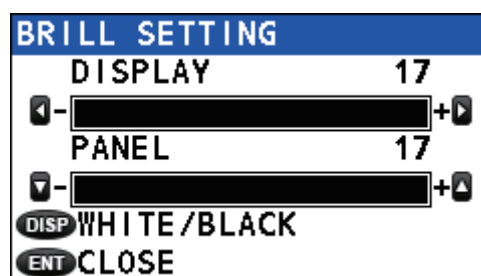

White background

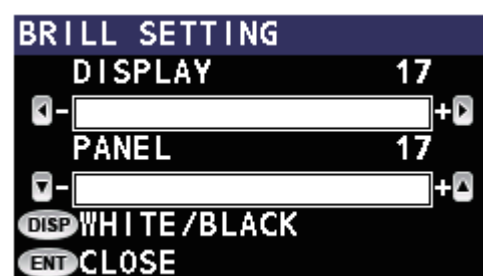

Black background

3. Press the **ENT** key to close the pop up window.

The background color can also be changed from the menu, see section 2.13.1.

2.4 Menu Overview

The main menu can be key code protected. For information on how to access and operate the main menu, see section 1.6.1.

For the sake of brevity, the following terminology is used in this manual:

Terminology	Meaning
"Select"	Example: "Select [SENSOR], then press the ENT key." Use the Cursorpad to select the menu item.
"Open the [MENU]."	Press the MENU ESC key; this opens the [MENU].
"Close the [MENU]."	<ul style="list-style-type: none"> Press the MENU ESC key; this closes the [MENU] and returns to the last used display screen or sub-screen. Press the DISP key; this closes the [MENU] and returns to the main screen.
IMO type	SC-70 or SC-130 systems which have been assigned as [MERCHANT] at installation and installed on vessels which meet the applicable IMO standards.
Non-IMO type	SC-70 or SC-130 systems which have been assigned as [FISHING] at installation and installed on vessels which do not meet the applicable IMO standards.
INTERNATIONAL	[TYPE APPROVAL] setting for international vessels other than Russia.
RUSSIA	[TYPE APPROVAL] setting for Russian vessels.

Note: The default operation mode for the SC-70/SC-130 is [MERCHANT] (IMO compliant). [FISHING] is not compliant with the IMO regulations and must not be used for vessels which are required to be IMO compliant. To change the operation mode, consult your local dealer.

1. Press the **MENU ESC** key to open the menu.

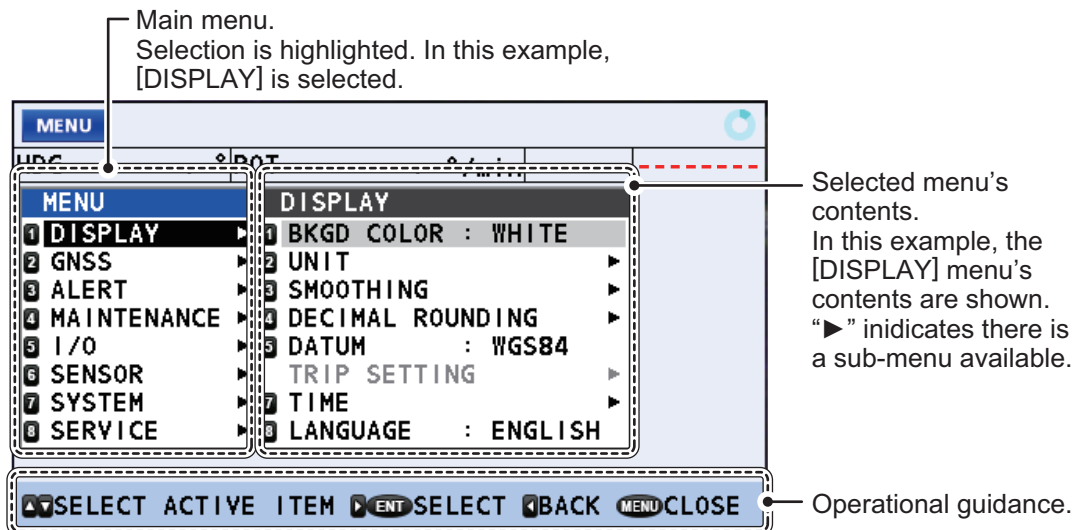

2. Press **▲** or **▼** to select a menu item, then press the **ENT** key.
"▶" next to a menu item indicates that there is a sub-menu available.
3. Press the **MENU ESC** key to close the menu.

2.5 LIST Screens Overview

LIST display mode shows the [ACTIVE ALERT] list, [ALERT LOG] and [DEVICE LIST] in cyclic order with the display mode currently in use.

Press the **LIST** key to cycle through the lists in the order shown below. Press and hold the **LIST** key to cycle through the lists in reverse order.



2.6 Display Modes Overview

The available display modes are GPS, THD, ROTI and SPD.

Note: The SPD display mode is available only for non-IMO compliant vessels. If the device mode is changed to [MERCHANT] and the SPD display mode is in use, it is automatically changed to the THD display mode. Consult your local dealer for details.

How to change the display mode

Press the **DISP** key to cycle through the display modes. The order in which the display modes are shown is: GPS → THD → ROTI → SPD → GPS...



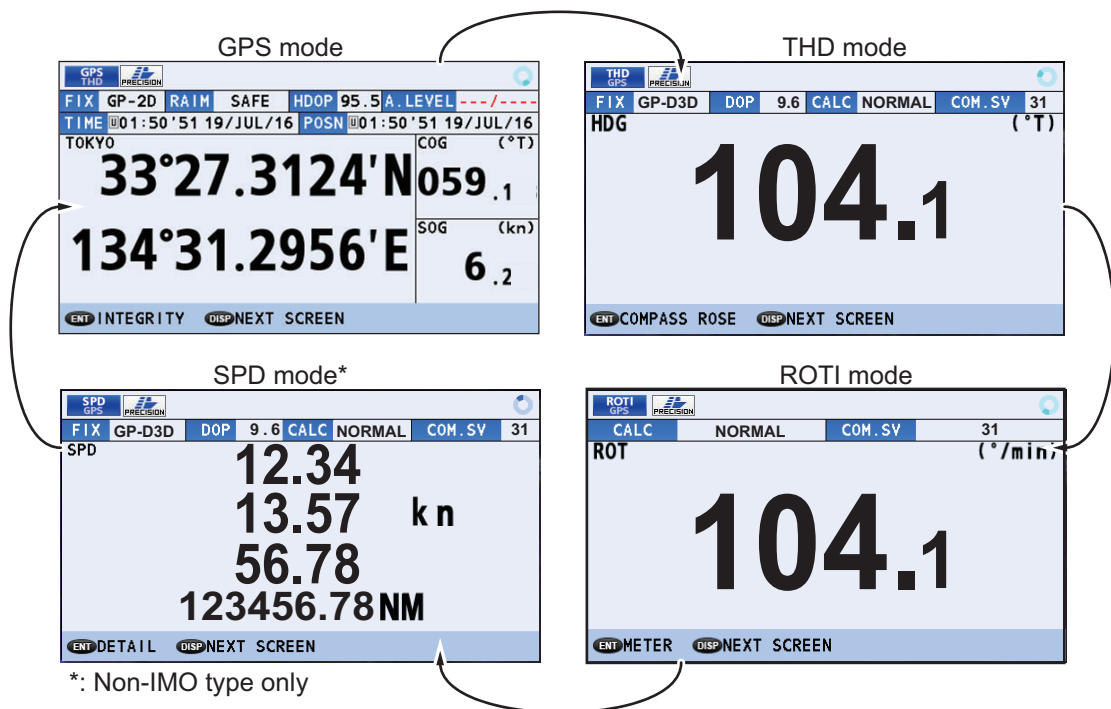

Note: Some display modes may not be available, depending on vessel configuration. The figures below shows all four available display modes.

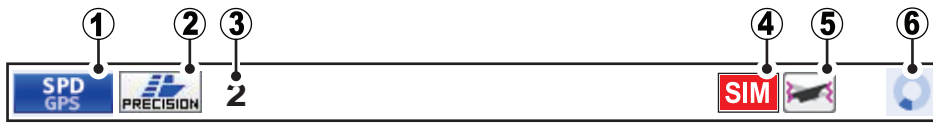

2.6.1 Icons and indications

The top section of all device modes displays various icons and the operational status icon is always displayed. The example figure below shows all icons, along with a brief description.



No.	Description
1	<p>Indicates the displayed screen.</p> <p>Display mode icon: (Two-tier)  — Current display mode — Preset [DEVICE MODE] (Startup screen)</p> <p>Display mode icon: (Single-tier)  — Indication appears on one line when the currently selected screen matches the preset [DEVICE MODE].</p> <p>LIST screen: </p> <p>MENU screen: </p>
2	Precision indicator - displayed when five or more satellites are available for position fixing.
3	GNSS core number - shown for non IMO-types only. Shown only when GNSS core 1 is faulty; the substituted core number is shown here.
4	Simulation mode indicator. Shown only when the system is in simulation mode.
5	Excessive vibration icon - displayed when the antenna location is subjected to excessive vibration.
6	Operational status indicator - rotates in a clockwise direction when the system is operating normally. If this indicator does not move for more than 30 seconds, restart the equipment. For Non IMO-types, this icon is displayed in a light-blue color. For IMO-types, this icon is displayed in a dark blue color.

Alerts and operational guidance

The bottom section of the screen for all device display modes shows operational guidance and alerts.

Alerts take priority over guidance and must be acknowledged before normal operational guidance can be displayed again.

Operational guidance



Alert message (flashing)



2.7 GPS Display Mode

The GPS display mode has three display screens. Press the **ENT** key to cycle through the screens in the following order: Main screen → INTERGITY → BEACON/TYPE 16 MESSAGE → main screen...

2.7.1 GPS coordinates screen (main screen)

The GPS main screen shows own position, COG, SOG and other important GPS information.

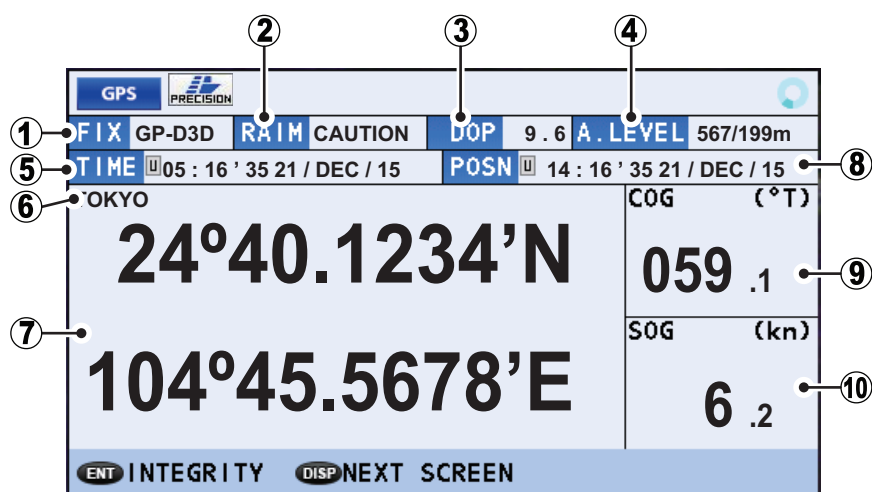

No.	Indication	Description
1	[FIX]	Current position fixing method (GP-3D, GP-D3D, etc.)
2	[RAIM]	Current RAIM status. <ul style="list-style-type: none"> • SAFE: GPS signal is normal, positioning accuracy satisfies the setting value. • CAUTION: RAIM accuracy cannot be calculated. (Signals from more than five GPS satellites are necessary.) The positioning accuracy does not satisfy the setting value. • UNSAFE: GPS signal is abnormal, therefore the positioning accuracy is not reliable. • OFF: RAIM is disabled.
3	[PDOP], [HDOP]	Current DOP (Dilution Of Precision). Displayed as PDOP for positional dilution, HDOP for horizontal dilution.
4	[A. LEVEL]	Accuracy offset for RAIM.
5	[TIME]	Time and date. Displayed with the prefix "L" for local time, "U" for UTC.
6	Datum	Current Datum in use.
7	Location	Own ship latitude and longitude (coordinates).
8	[POSN]	Time and date of last position calculation. Displayed in a orange color when the unit is restarted. When connection is established and positioning can be calculated, the indication changes to the opposite color of the setting selected from the [DISPLAY] → [BKGD COLOR] menu.
9	[COG]	Course Over Ground.
10	[SOG]	Speed Over Ground.

2.7.2 GPS integrity screen

The GPS integrity display shows satellite status and various integrity-related data, as shown in the figure and table below.

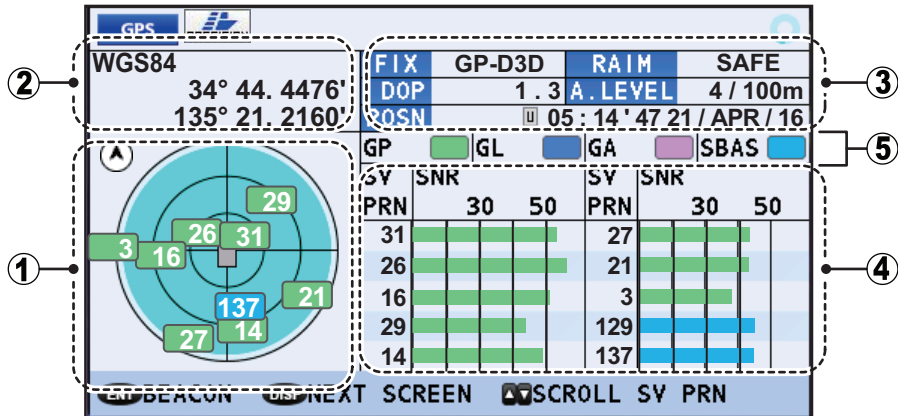

No.	Name	Description
1	Satellite positions	Shows the available satellites and their elevation. <ul style="list-style-type: none"> • Light blue shaded circle: Indicates area where multipath can be used. • White numerals: Indicates satellites used for position fix. • Own ship is shown at the center of the circle. Press ► to alternate between North-Up and Head-Up orientations.
2	Own ship position/positioning reference	Shows OS coordinates and positioning reference.
3	Text data box	See section 2.7.1.
4	RX level	Shows the strength of the signal received from the satellite code. <ul style="list-style-type: none"> • [SV PRN]: Satellite number. • [SNR]: Signal to Noise Ratio. When more than 10 satellites are in use, press ▲ or ▼ to scroll though the list.
5	Satellite color codes	Shows the color code for the satellites currently in use. The displayed indications are abbreviated as follows: <ul style="list-style-type: none"> • [GP]: GPS. • [GL]: GLONASS. • [GA]: Galileo • [SBAS]: SBAS

2.7.3 BEACON INFO/TYPE 16 MESSAGE screen

The beacon information display screen has two information tabs, the [BEACON INFO] tab and the [TYPE16 MESSAGE] tab.

The GPS [BEACON INFO] tab displays important information about the selected GPS beacon.

The [TYPE16 MESSAGE] tab displays all received TYPE16 messages received from beacons.

To switch tabs, press either the ◀ or the ▶ arrow key.

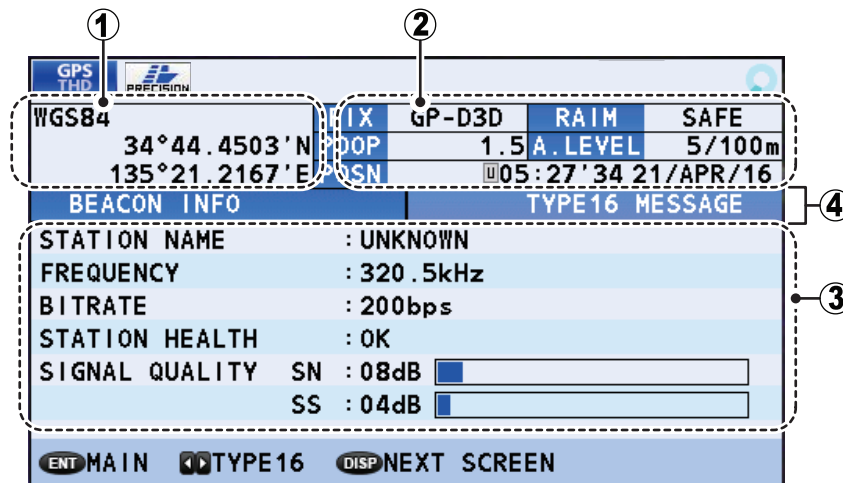

No.	Name	Description
1	Own ship position/positioning reference	Shows OS coordinates and positioning reference
2	Text data box	See section 2.7.1.
3	Information/message box	BEACON INFO tab: <ul style="list-style-type: none"> • STATION NAME: Always shown as "UNKNOWN". • FREQUENCY: Beacon/station's frequency • STATION HEALTH: Always shown as "Not Available". • SIGNAL QUALITY: SN = Signal to noise ratio (range: 00 dB to 99 dB); SS = Signal strength (range: 00 dB to 99 dB). Note: Where the value for SN or SS exceeds the maximum displayable value, the indicated value appears as bars ("99dB").
4	[BEACON INFO] / [TYPE16 MESSAGE] tabs	Displays beacon information ([BEACON INFO] tab), or displays received [TYPE16 MESSAGE] messages.

2.8 THD Display Mode

THD (Transmitting Heading Device) display mode outputs heading data to external equipment. This display mode has five sub display screens. The default screen is the HDG (heading) data screen. The sub screens, in displayed order, are: Compass Rose screen → ROT (Rate Of Turn) screen → HDG/ROT split screen → HDG/TIME/COG/SOG split screen → THD integrity screen.

Press the **ENT** key to cycle through the display screens.

2.8.1 HDG data screen

The HDG data screen shows your current heading and any offset applied to the heading data.

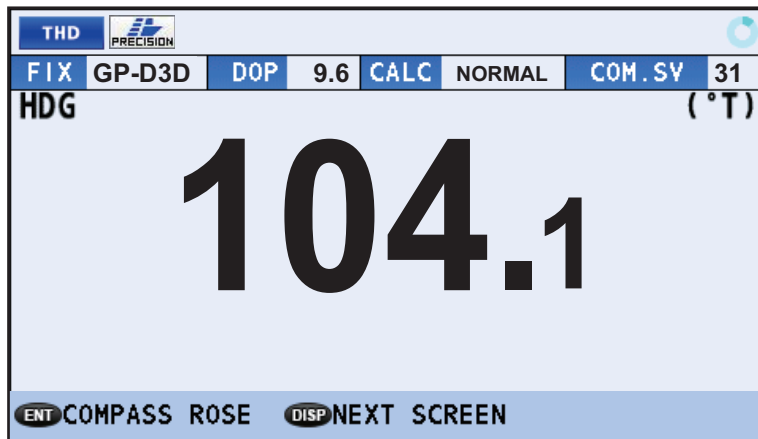

How to interpret the THD data display screen



Indication	Description
FIX	Current position fixing method (GP-3D, GP-D3D, etc.)
PDOP	Current DOP (Dilution Of Precision). Displayed as PDOP for positional dilution, HDOP for horizontal dilution.
CALC	Calculation status. <ul style="list-style-type: none"> • [NORMAL]: HDG and ROT are calculated normally. • [DR]: HDG and ROT are calculated using Dead Reckoning. • [STOPPED]: HDG calculation stopped. • [SYS FAULT]: System fault.
COM. SV	Commonly used satellite's number.

2.8.2 Compass Rose data screen

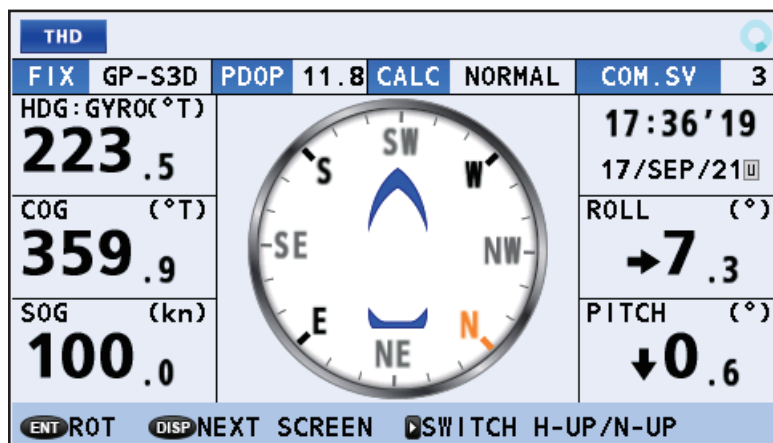
The Compass Rose data screen shows heading with compass.

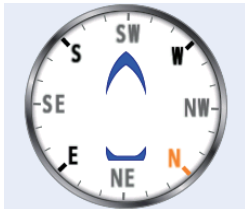

How to interpret the Compass Rose data screen

Indication	Description
FIX	Current position fixing method (GP-3D, GP-D3D, GP-S3D, etc.)
PDOP	Current DOP (Dilution Of Precision). Displayed as PDOP for positional dilution, HDOP for horizontal dilution.
CALC	Calculation status. <ul style="list-style-type: none"> [NORMAL]: HDG and ROT are calculated normally. [DR]: HDG and ROT are calculated using Dead Reckoning. [STOPPED]: HDG calculation stopped. [SYS FAULT]: System fault.
COM. SV	Commonly used satellite's number.
HDG	Current heading
COG	Course Over Ground
SOG	Speed Over Ground
TIME	Time and date. Displayed with the prefix "L" for local time, "U" for UTC.
ROLL	Shows the degree of roll.
PITCH	Shows the degree of pitch.
SWITCH H-UP/N-UP	Press ► key to alternate between North-Up and Head-Up orientations as shown below (Head-Up is set as default setting). <div style="display: flex; justify-content: center; align-items: center; gap: 20px;"> <div style="text-align: center;">  <p>Head-Up orientation</p> </div> <div style="text-align: center;">  <p>North-Up orientation</p> </div> </div>

2.8.3 ROT data screen

The ROT data screen shows your vessel's current rate of turn.

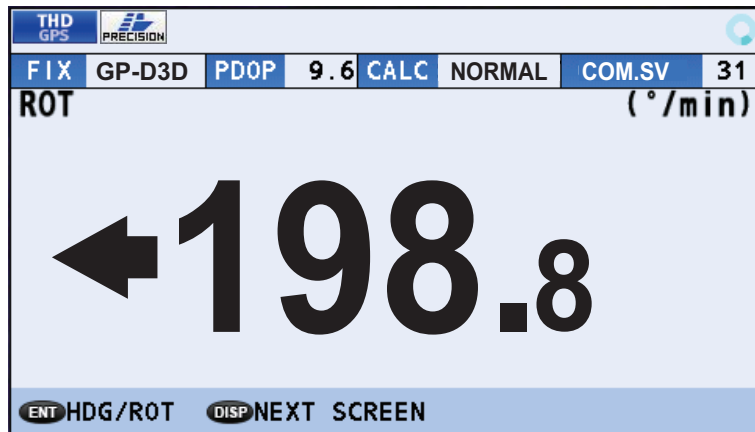

How to interpret the ROT data screen

Indication	Description
FIX	Current position fixing method (GP-3D, GP-D3D, etc.)
PDOP	Current DOP (Dilution Of Precision). Displayed as PDOP for positional dilution, HDOP for horizontal dilution.
CALC	Calculation status. <ul style="list-style-type: none"> • [NORMAL]: HDG and ROT are calculated normally. • [DR]: HDG and ROT are calculated using Dead Reckoning. • [STOPPED]: HDG calculation stopped. • [SYS FAULT]: System fault.
COM. SV	Commonly used satellite's number.

2.8.4 HDG/ROT split screen

The HDG/ROT split screen shows heading and rate of turn data with roll/pitch/heave.

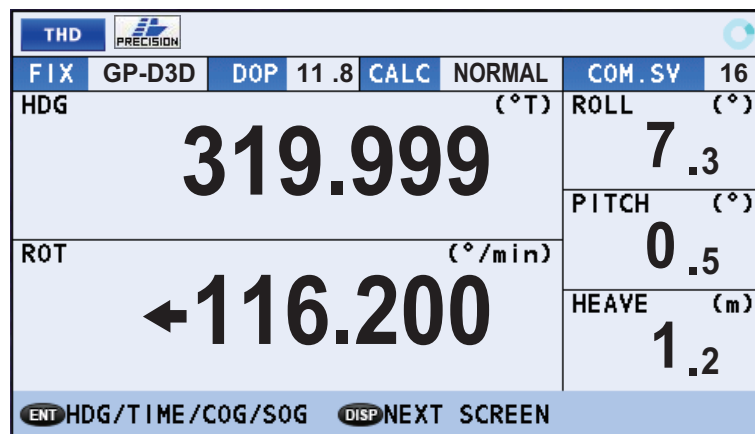

2.8.5 HDG/TIME/COG/SOG split screen

The HDG/TIME/COG/SOG split screen shows heading, time, Course Over Ground and Speed Over Ground data.

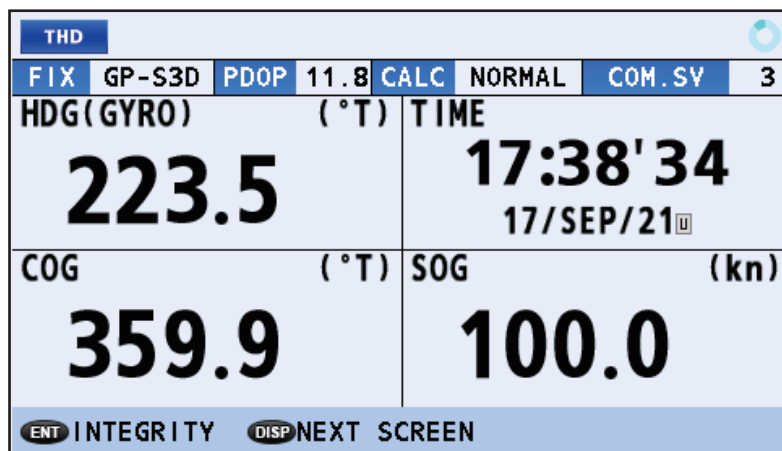

2.8.6 THD integrity screen

The THD integrity display shows satellite status and various integrity-related data, as shown in the figure and table below.

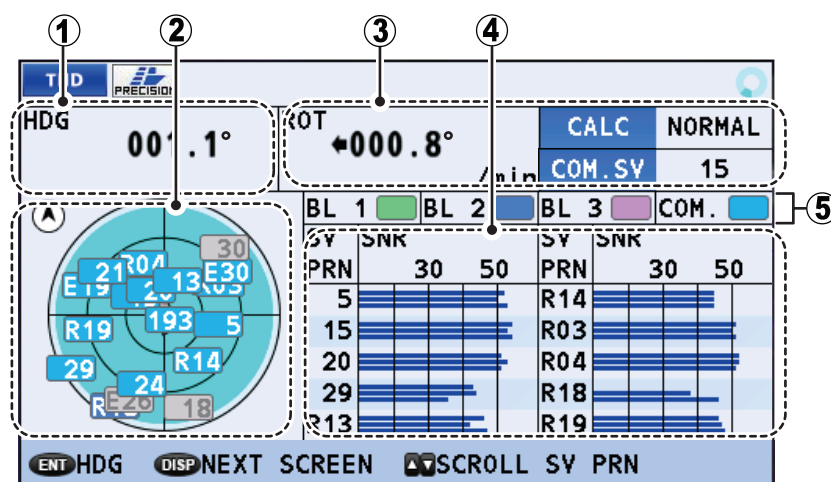

No.	Indication	Description
1	HDG	Current heading.
2	Available satellites	Shows the available satellites and their elevation. Press ► to alternate between North-Up and Head-Up orientations.
3	<ul style="list-style-type: none"> • ROT • CALC • COM. SV 	<ul style="list-style-type: none"> • Current Rate Of Turn. • Calculation status. (See the table in “HDG data screen” subsection 2.8.1 for details.) • Commonly used satellite’s number.
4	Satellite details	Shows the strength of the signal received from the satellites. More than one bar indicates that more than one antenna is using that satellite. <ul style="list-style-type: none"> • [SV PRN]: Satellite number. • [SNR]: Signal to Noise Ratio. When more than 10 satellites are in use, press ▲ or ▼ to scroll though the list.

No.	Indication	Description
5	Antenna baseline color codes	Shows the color for each antenna baseline in use. The displayed indications are abbreviated as follows: <ul style="list-style-type: none"> • [BL 1] - Antenna No. 1 + Antenna No. 2 • [BL 2]* - Antenna No. 2 + Antenna No. 3 • [BL 3]* - Antenna No. 3 + Antenna No. 1 • COM - Common *: Shown only when a SC-1303 is connected.

2.9 ROTI Display Mode

The ROTI display mode is essentially the same as the THD display mode, in terms of displayed data. However, the following items are displayed in a different manner:

- [DOP] and [FIX] are not shown.
- The indications for [ROT] and [HDG] in the split-screen are reversed.

This display mode has three sub display screens. The default screen is the ROT (Rate Of Turn) data screen. The sub screens, in displayed order, are: ROT analog meter screen → HDG (Heading) screen → ROT/HDG split screen → THD integrity screen.

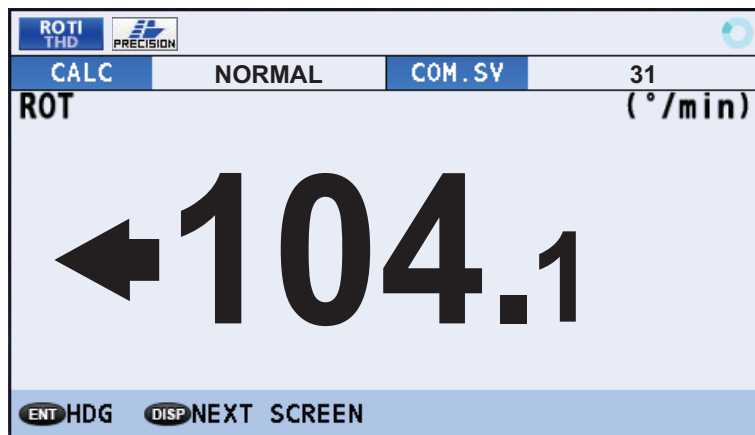

2.9.1 ROTI analog meter screen

In the ROT analog meter screen, the ROT data is displayed in an analog meter format. When the ROT value exceeds 30° (degrees), the meter needle will be as the illustration on right side.

When ROT value is 10 degrees (to the PORT)

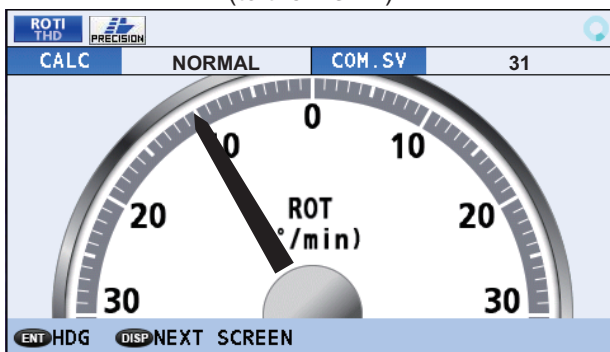

When ROT value exceeds the 30 degrees (to the PORT)

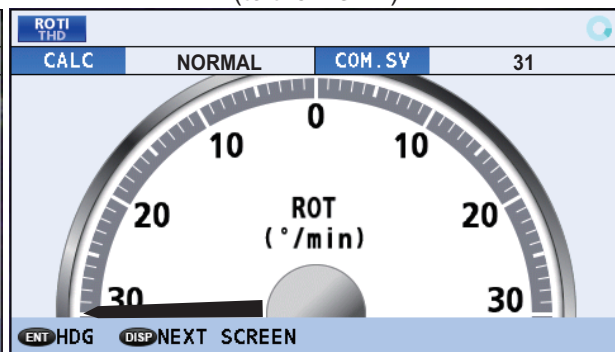

2.9.2 ROTI Display for RD-50/RD-20 (option)

For vessels with the optional RD-50/RD-20 installed as part of the SC system configuration, you can show the ROTI data on the RD-50/RD-20 display. See the appropriate operator's manual for details (RD-50: OME-44530-x; RD-20: OME-44540-x; "x" denotes the manual version).

Note: For IMO-type vessels, the RD-50 remote display is compatible with IMO regulations. If you use the RD-20 remote display, your vessels no longer meets the IMO requirements.

2.10 SPD Display Mode (Non-IMO types only)

The speed and distance data display screen is the default. The sub screen shows navigational data. This display mode is only available for non-IMO types.

2.10.1 Speed and distance display screen

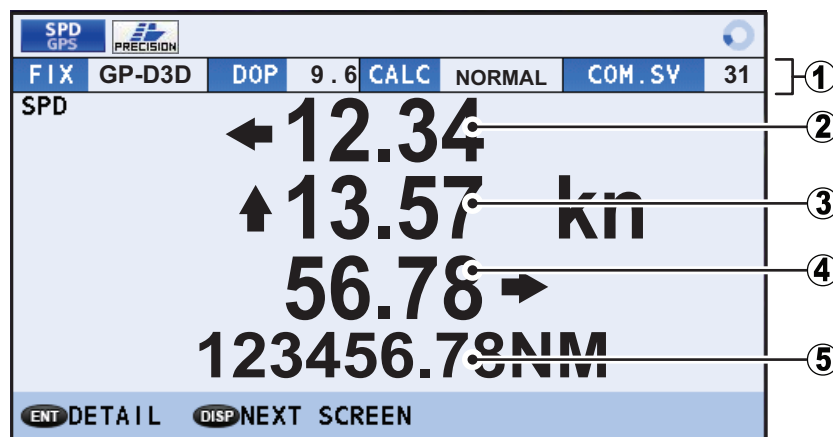

How to interpret the speed and distance display screen

No.	Indication	Description
1	[FIX], [DOP], [CALC], [COM.SV]	See section 2.8.1.
2	Lateral bow speed*	Shows the calculated speed at the bow of your vessel. The arrow indicates tendency to port or starboard.
3	Bow to stern speed*	Shows the calculated speed of your vessel. The arrow indicates forward or reverse motion.
4	Lateral stern speed*	Shows the calculated speed at the stern of your vessel. The arrow indicates tendency to port or starboard.
5	Distance traveled	Shows the distance traveled for this trip.

*: CALC-SPD values must be set at installation to show these speeds. See section 1.6.2 for details.

2.10.2 Navigational data screen

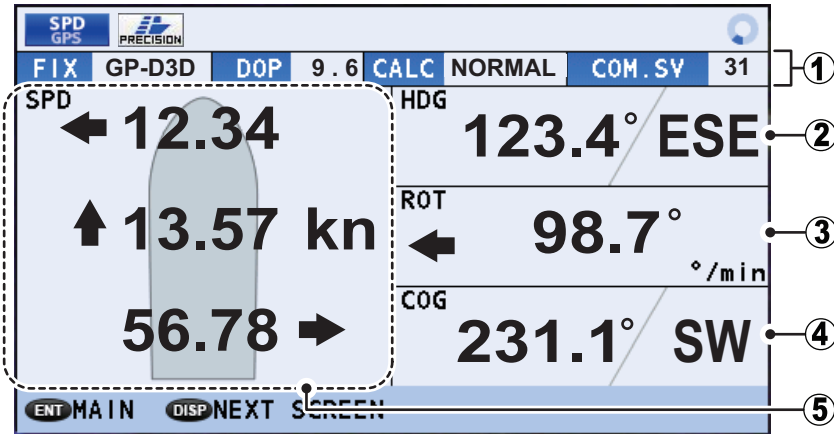

How to interpret the navigational data

No.	Indication	Description
1	FIX	See section 2.8.1.
2	HDG	Current heading
3	ROT	Rate of turn.
4	COG	Course Over Ground.
5	Speed data	Top line: Lateral bow speed. Middle line: Bow to stern speed. Bottom line: Lateral stern speed.

2.11 Alerts

2.11.1 What is an Alert?

"Alert" is a generic name for a notice to any unusual or potentially dangerous situation generated within the system.

Alerts are classified according to priority and category.

Alert priority

There are three alert priorities: alarm, warning and caution.

Alarm: Situations or conditions which require immediate attention, decision and (if necessary) action by the bridge team to avoid any kind of hazardous situation and to maintain the safe navigation of the ship.

Warning: Conditions or situations which require immediate attention for precautionary reasons, to make the bridge team aware of conditions which are not immediately hazardous, but may become so.

Caution: Awareness of a condition which continues to require attention out of the ordinary consideration of the situation or of given information.

Alert category

An alert is further classified by category, A, B or C, according to its degree of severity or source.

Category	Description
A	Category A alerts include the following, and must be confirmed from the equipment that generated the alert. <ul style="list-style-type: none"> • Danger of collision • Danger of grounding
B	Category B alerts are alerts where no additional information for decision support is necessary. Category B alerts are all alerts not falling under category A.
C	IAS (Integrated Automation System) generated engine alert

2

When an alert is triggered, a flashing indication appears at the bottom of the screen and an alert sound is released. The indication shows the alert icon, alert number (code) and the alert name.

[Warning] level alerts are shown in yellow-orange color, [Caution] level alerts are shown in yellow color.

When more than one alert is active, the highest priority alert appears in the flashing indication. Other active alerts are indicated with an icon, located to the right edge of the flashing indication.

Example alert message (flashing)



These icons only appear when multiple alerts of the related level are active.

The icon also shows the alert level:

“W” for Warnings and “C” for Cautions.

The SC-70/SC-130 tracks active (acknowledged but not rectified, or unacknowledged) alerts in the [ALERT LIST] (see section 2.11.5). Alerts which are acknowledged and rectified are saved in the [ALERT LOG] (see section 2.11.6).

For a full list of possible alerts, along with their details such as alert codes and remedies or action required, see "ALERT LIST" on page AP-4.

Alert icons

This equipment uses alert icons to indicate the alert level and status. For a list of the possible icons, see "Alert icons and their meanings" on page AP-10.

2.11.2 How to acknowledge alerts

There are three methods by which you can acknowledge an alert.

How to acknowledge an alert from the display unit (All alert modes)

Press the **ACK** key to acknowledge the alert.

How to acknowledge an alert remotely (IMO alert mode)

Alerts output by this equipment can be acknowledged remotely when displayed at equipment on the same network. Refer to the related equipment's manual for how to acknowledge an alert at that equipment.

How to acknowledge an alert remotely (LEGACY alert mode)

The [REMOTE ACK I/F] setting sets the behavior of external equipment which can acknowledge alerts. To use this function, the [ALERT MODE] must be set to [LEGACY] at installation. (Consult your dealer to change this setting.)

To set remote acknowledge, do the following.

1. Open the [MENU].
2. Select [ALERT], then press the **ENT** key.
3. Select [REMOTE ACK I/F], then press the **ENT** key.
4. Select the appropriate setting, then press the **ENT** key.

Setting	Description
[ACK]	External equipment can acknowledge alerts.
[BUZZER STOP]	External equipment can stop aural alerts, but cannot acknowledge alerts.

5. Close the [MENU].

Refer to the operator's manual for the external equipment for alert acknowledgment procedures.

2.11.3 How to silence alerts

When connected to the same network, alerts output by this equipment can be silenced remotely. Refer to the related equipment's manual for how to silence an alert at that equipment.

Note: The buzzer sounds again if the alert condition is not rectified or the alert is not acknowledged within 30 seconds.

2.11.4 How to enable/disable the aural alert (Non-IMO type only)

This setting is only available for non-IMO types.

1. Open the [MENU].
2. Select [ALERT], then press the **ENT** key.
3. Select [SOUND], then press the **ENT** key. An options pop up window appears.
4. Select the appropriate option, then press the **ENT** key.

Option	Description
[OFF]	Disable aural alerts.
[SHORT]	Release two short beeps when an alert is triggered.
[LONG]	Release three long beeps when an alert is triggered.
[CONTINUOUS]	Release a continuous beep when an alert is triggered.

5. Close the [MENU].

2.11.5 How to access the alert list

The alert list shows all currently violated alerts and state of acknowledgment.

All unacknowledged alerts are shown, even those whose reason for the alert has been rectified or passed (except for cautions). To access the alert list, do the following:

1. Open the [MENU].
2. Select [ALERT], then press the **ENT** key.
3. Select [ALERT LIST], then press the **ENT** key. The list of active alerts appears.

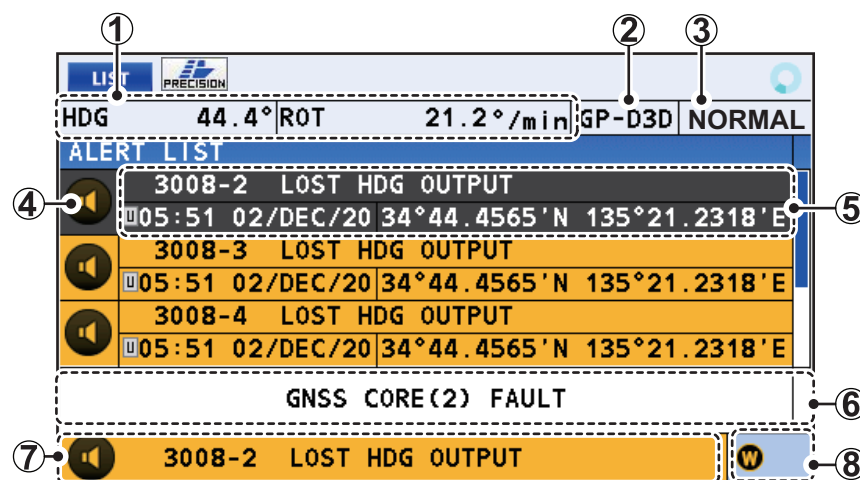

If no alerts are active, the list shows the message "NO ACTIVE ALERTS".

4. Press ▲ or ▼ to scroll up or down through the alert log.
To see the highest priority alert, press ◀.
To see the lowest priority alert, press ▶.
5. Press the **DISP** key to close the [ALERT LIST].

Note 1: You can also access the [ALERT LIST] from the [LIST] display. Press the **LIST** key to cycle through the lists.

Note 2: The time and date shown in this equipment is derived from the connected satellites. When connection (view) to the satellites is stopped or interrupted, the next available satellite's data is used. This equipment outputs the time and date, as part of the ZDA sentence, to the connected network and may be used for UTC synchroniza-

2. OPERATION

tion by other equipment. If the output ZDA sentence is interrupted to stopped, the connected equipment may not show the correct time.

How to interpret the alert list

No.	Indication name	Description
1	DATUM/OS coordinates or [HDG]/[ROT]	<p style="text-align: center;"><u>Where the device mode is [THD] or [ROT]:</u></p> <ul style="list-style-type: none"> • [HDG]: OS heading, oriented to North. If the heading data is received from an external device, the device name and external input talker are shown. • [ROT]: Rate of turn with arrow indicating turn direction to port or starboard. <p style="text-align: center;"><u>Where the device mode is [SPD] or [GPS]:</u></p> <p>Datum and OS coordinates are displayed.</p>
2	FIX	Current position fixing method (GP-3D, GP-D3D, etc.)
3	CALC	<p>Calculation status.</p> <ul style="list-style-type: none"> • [NORMAL]: Data is calculated normally. • [DR]: Data is calculated using Dead Reckoning. • [STOPPED]: Data calculation stopped. • [SYS FAULT]: System fault.
4	Alert icon	Shows alert status. See page AP-10 for details.
5	Alert details	<p>Top line: alert code, alert title</p> <p>Bottom line: time of alert, coordinates at time of alert.</p> <p>Note: A full list of alert codes, meaning and measure is included at "ALERT LIST" on page AP-4.</p>
6	Alert text	Selected alert's message text.
7	Active alert	Shows the highest priority active alert.
8	Background icons	Shows the icon(s) for background alerts. This area is blank if there are no active background alerts.

Background alerts

Background alerts are alerts which are active at the same time as a higher priority alert. If there are two alerts of the same priority, the alert which occurred first (earliest) is shown in the "active alert" area of the list and the second (later) alert is shown as an icon. Warning level background alerts appear with a "W" icon, Caution level background alerts appear with a "C" icon.

2.11.6 How to access the alert log

The alert log shows the latest 50 alerts. When the log becomes full, the oldest entry is erased to make room for current alerts. To access the alert log, do the following:

1. Open the [MENU].
2. Select [ALERT], then press the **ENT** key.
3. Select [ALERT LOG], then press the **ENT** key.

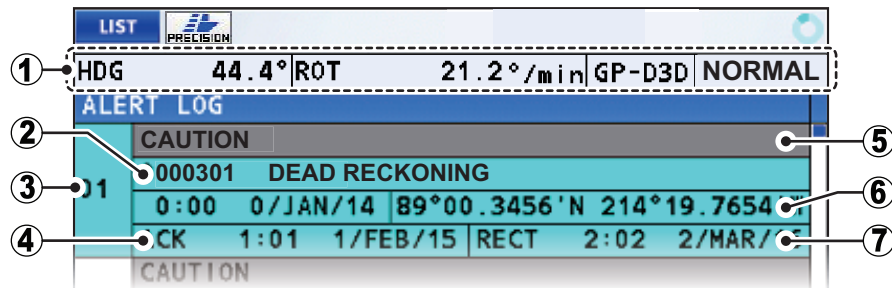

4. Press **▲** or **▼** to scroll up or down through the alert log.
5. Press the **DISP** key to close the [ALERT LOG].

Note 1: The [ALERT LOG] can also be accessed from the [LIST] display. Press the **LIST** key to cycle through the lists.

Note 2: The time and date shown in this equipment is derived from the connected satellites. When connection (view) to the satellites is stopped or interrupted, the next available satellite's data is used. This equipment outputs the time and date, as part of the ZDA sentence, to the connected network and may be used for UTC synchronization by other equipment. If the output ZDA sentence is interrupted to stopped, the connected equipment may not show the correct time.

How to interpret the alert log

No.	Indication name	Description
1	DATUM, OS coordinates, Calculation status, [HDG], [ROT]	See section 2.11.5.
2	Alert code and message	Alert code appears in six digit format. Note: A full list of alert codes, meaning and measure is included at "ALERT LIST" on page AP-4.
3	Alert number	Number assigned to the selected alert by the alert log. Up to 50 alerts are stored. Note: This is not an alert code.
4	[ACK]	Time and date the alert was acknowledged.
5	Alert priority	The priority level assigned to the selected alert. Displayed as "WARNING" or "CAUTION".
6	Alert time / coordinates	Time of alert, coordinates at time of alert.
7	[RECT]	Time and date alert was rectified.

2.11.7 Responsibility transfer alert

MSC302(87) requires the use of the "responsibility transfer alert" which functions in the multiple sensor, multiple equipment installation. When one sensor or one equipment fails but does not disturb the system operation (other sensor or equipment is normal), the AMS automatically sends the "responsibility transfer alert" (ACN sentence) to the sensor or equipment that generated the alert.

Note: All ALERT I/F2 Warning level alerts have responsibility transfer function. Caution level alerts do not have responsibility transfer function.

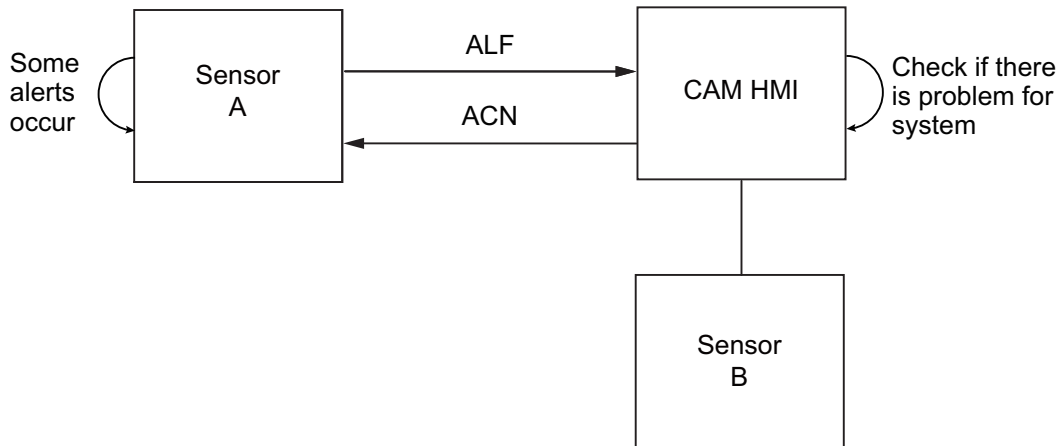

If the sensor or equipment refuses the responsibility transfer, normal operation is restored.

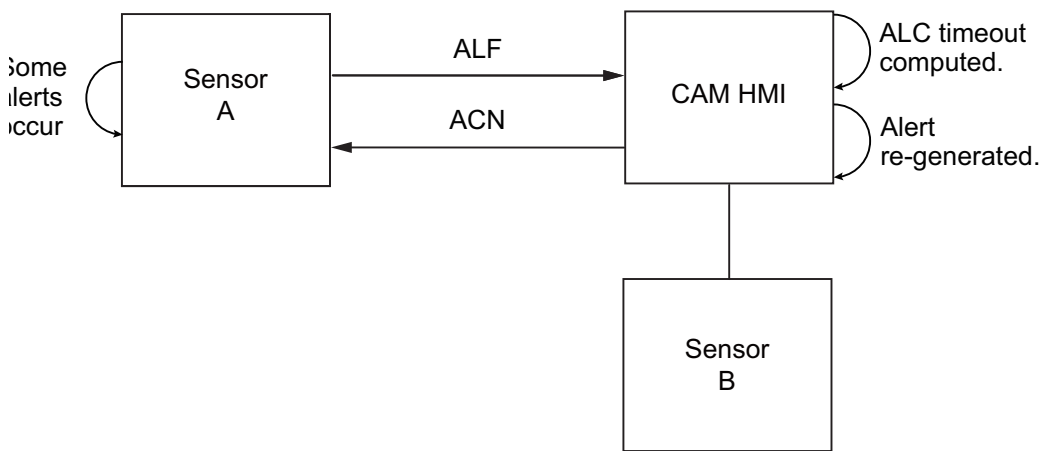

If the ALC sentence is not received from equipment within the prescribed time interval, the alert processed as responsibility transfer alert is made active and the "System communication fail" alert is generated.

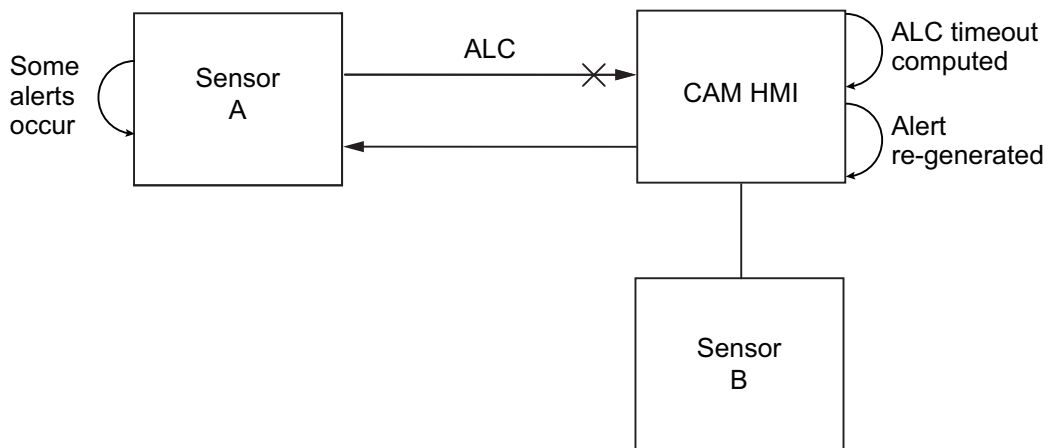

2.11.8 Alert escalation

All ALERT I/F2 Warning level alerts are escalated as Warning level alerts if they are not acknowledged or rectified within five minutes.

Caution level alerts are not escalated.

2.11.9 Alert continuation

Active alerts are terminated and their status is changed to “normal” under the following circumstances.

- When the [Device Mode] is changed. (Requires [SERVICE] menu login.)
- When the [Alert Mode] is changed. (Requires [SERVICE] menu login.)
- When the [Demo Mode] is activated/deactivated.

2.11.10 UTC de-synchronization and alert output

For vessels assigned as [RUSSIAN] at installation, the time/date field of some alerts sentences may be output as "null" under the following circumstances.

- The system is starting up.
- The system is unable to obtain a position fix.

2.13 DISPLAY Menu

You can customize the manner in which most items are displayed on your screen, from the [DISPLAY] menu.

Press the **MENU ESC** key, select [DISPLAY], then press the **ENT** key to show the [DISPLAY] menu.



2.13.1 How To Change the Display Color

You can change the background and text color for better visibility. There are two options, White background and Black background.



The color change can be made using of the two following methods:

How to change the color from the menu

1. Open the [DISPLAY] menu.
2. Select [BKGD COLOR], then press the **ENT** key.
3. Select [BLACK] or [WHITE] as appropriate, then press the **ENT** key.
4. Close the [MENU].

How to change the color from the controls

See section 2.3.2 for details.

2.13.2 How to Change the Units of Measurement

To change the unit of measurement for distance, follow the procedure below.

1. Open the [DISPLAY] menu.
2. Select [UNIT], then press the **ENT** key.
3. [DISTANCE] is selected, press the **ENT** key.
4. Select the appropriate distance unit, then press the **ENT** key.

Note: The unit of measurement for speed is also changed, as shown below

- [NM]: Nautical Miles - speed shown as [kn].
- [KM]: Kilometers - speed shown as [km/h].
- [SM]: Statute Miles - speed shown as [mph].

5. Close the [MENU].

2.13.3 How To Use The Smoothing Menu

Data received from external sensors can be smoothed. This helps to reduce variations caused by unfavorable receiving conditions or other factors.

1. Open the [DISPLAY] menu.
2. Select [SMOOTHING], then press the **ENT** key.
3. Select the appropriate item to smooth, then press the **ENT** key.

Menu item	Description	Setting range
SOG/COG	Course over ground, ground speed	0000 s to 9999 s
6DoF	Six Degrees of Freedom - Roll/Pitch	0000 s to 9999 s
3AXIS SPEED	Dual water/ground speed	0000 s to 9999 s Note: Available for non-IMO types only.
ROT	Rate of turn	00 s to 30 s

4. Close the [MENU].

To disable smoothing for any of the above menu items, repeat the above procedure, then set the smoothing value to [0] (zero).

2.13.4 How to set the number of digits after a decimal point

To change the number of digits displayed after a decimal point, follow the procedure below. Up to three digits can be set.

1. Open the [DISPLAY] menu.
2. Select [DECIMAL ROUNDING], then press the **ENT** key.
3. Select the appropriate item, then press the **ENT** key.

Item	Affected indications
[VTG]	Speed indications which use the VTG sentence for data input.
[VBW]	Speed indications which use the VBW sentence for data input.
[HDG]	All heading indications. ([ROT] is also affected, see section 2.8.3.)
[ROLL, PITCH]	All roll/pitch indications. ([HEAVE] is also affected, see section 2.8.4.)

4. Select [1], [2] or [3] as appropriate, then press the **ENT** key.
 - [1]: Values are displayed with one digit after the decimal point. The values are also rounded up or down as appropriate.
 - [2]: Values are displayed with two digits after the decimal point. The values are also rounded up or down as appropriate.
 - [3]: Values are displayed with three digits after the decimal point. The values are also rounded up or down as appropriate.

Note: This setting also affects serial output data, sent to other equipment.

5. Close the [MENU].

2.13.5 How to Set Geodetic Data

The SC-70/SC-130 uses the WGS84 datum as the default geodetic datum. To change the datum used, follow the procedure below.

1. Open the [DISPLAY] menu.
2. Select [DATUM], then press the **ENT** key.
3. Select the appropriate datum, then press the **ENT** key. The available selections are: [WGS84], [WGS72], [PZ90], [CK42], [CK95] and [OTHERS].
If the datum you wish to use is not displayed, select [OTHERS].
4. If you selected [OTHERS], proceed to step 5. For all other selections, close the menu.
5. Input the chart number, referring to the geodetic chart list at the back of this manual, then press the **ENT** key.
6. Close the [MENU].

2.13.6 How to Reset the Trip Meter

The trip meter calculates the distance your vessel has traveled and can be restarted at any time. This menu is not available for IMO types.

To reset the trip meter, do the following:

1. Open the [DISPLAY] menu.
2. Select [TRIP SETTING], then press the **ENT** key.
3. [CLEAR] is already selected. Press the **ENT** key to reset the meter.
4. Close the [MENU].

2.13.7 How to Adjust the Date and Time

The SC-70/SC-130 can display the date and time in UTC format or as the local (geographical) time. You can also set for summer time. To adjust time settings, refer to the appropriate topic below.

Note: These settings are only applied to the SC-70/SC-130 display and do not affect the time/date included in the ZDA sentence when output.

How to change the time display format

1. Open the [DISPLAY] menu.
2. Select [TIME], then press the **ENT** key.
3. Select [LOCAL TIME], then press the **ENT** key.
4. Select [UTC] or [LOCAL] as appropriate, then press the **ENT** key.

Setting	Remarks
[UTC]	UTC (Coordinated Universal Time) time is calculated automatically.
[LOCAL]	Manually input the time offset (based on UTC time).

5. Close the [MENU].

How to enable/disable summer time

You can manually adjust the time to reflect summer (daylight saving) time.

1. Open the [DISPLAY] menu.
2. Select [TIME], then press the **ENT** key.
3. Select [SUMMER TIME], then press the **ENT** key.
4. Select [ON] to enable summer time, [OFF] to disable summer time.
5. Close the [MENU].

2.13.8 How to Set the Display Language

The SC-70/SC-130 can display menus and data in English or Japanese. If the display language has been changed to Japanese, do the following to change the language back to English.

Note: This procedure uses the menu item numbers which are displayed at the left-side of each menu.

1. Open the [MENU].
2. Select [1], then press the **ENT** key.
3. Select [8], then press the **ENT** key.
4. Select [ENGLISH], then press the **ENT** key.
5. Close the [MENU].

2.14 GNSS Menu

You can adjust various GNSS-related settings from the [GNSS] menu.

Press the **MENU ESC** key, select [GNSS], then press the **ENT** key to show the [GNSS] menu.

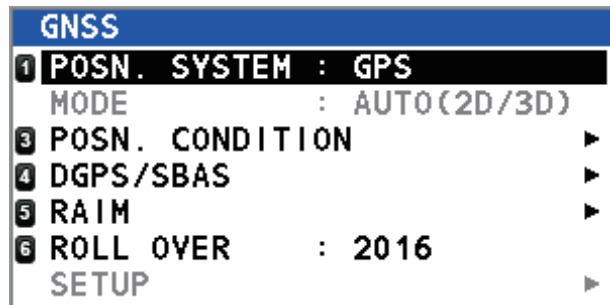

2.14.1 How to select the positioning system to use

1. Open the [GNSS] menu.
2. Select [POSN. SYSTEM], then press the **ENT** key.
3. Select the appropriate positioning system, then press the **ENT** key.
Note: Only [GPS] is available for selection.
4. Close the [MENU].

2.14.2 How to set the positioning conditions

1. Open the [GNSS] menu.
2. Select [POSN. CONDITION], then press the **ENT** key.
3. Referring to the table below, set the conditions for position fixing, then press the **ENT** key.

Menu item	Options	Remarks
QZSS	<ul style="list-style-type: none"> • [OFF] • [ON] (default) 	Enable/disable the use of the QZSS system.
ELEVATION MASK	For technical personnel only. Not changeable.	
IGNORED GNSS	[000] to [999]	<p>The system uses the on-board almanac to ignore satellites which are known to provide incorrect data. However, some of these satellites may not be registered in the almanac. You can add satellites to be ignored using this function.</p> <p>1) Select the satellite network to which the satellite you want to ignore is registered. The [IGNORED SATELLITE] window appears.</p> <p>2) Enter the satellite number to be ignored. You can enter up to 3 satellites per network. Press ▲ to increase the value, ▼ to decrease the value and press ► or ◀ to move the input cursor.</p> <div style="display: flex; align-items: center; justify-content: center;"> <div style="border: 1px solid black; padding: 5px; margin-right: 10px;"> <p style="text-align: center; margin: 0;">IGNORED GNSS</p> <p style="margin: 0;">1 QZSS</p> <p style="margin: 0;">2 GPS</p> <p style="margin: 0;">3 GLONASS</p> <p style="margin: 0;">4 GALILEO</p> </div> <div style="font-size: 2em; margin-right: 10px;">➔</div> <div style="border: 1px solid black; padding: 5px; margin-left: 10px;"> <p style="text-align: center; margin: 0;">IGNORED SATELLITE</p> <p style="text-align: center; margin: 0;">▲ 000 ▼</p> <p style="text-align: center; margin: 0;">000</p> <p style="text-align: center; margin: 0;">000</p> <p style="text-align: center; margin: 0;">ENTER CANCEL</p> </div> </div> <p>3) Select [ENTER], then press the ENT key.</p>

4. Close the [MENU].

2.14.3 How to Set Up DGPS/SBAS

The SC-70/SC-130 can connect to DGPS beacons or SBAS (Satellite Based Augmentation Systems) to refine position fixing.

How to select the mode of refinement

- 1) Open the [GNSS] menu.
- 2) Select [DGPS/SBAS], then press the **ENT** key.
- 3) Select [DIFFERENTIAL], then press the **ENT** key.
- 4) Referring to the list below, select the appropriate mode, then press the **ENT** key.
 - [GNSS]: No position refinement used.
 - [GNSS+SBAS]: Use SBAS to refine position fixing.
 - [GNSS+EXTERNAL]: Use beacons to refine position fixing.
Note: The [MODE] setting for [DATA5] in the [I/O] menu must be set to [RTCM] to enable this mode.
 - [AUTO]: The SC-70/SC-130 automatically switches modes as required.
The priority is: [EXTERNAL] > [SBAS] > [GNSS].
- 5) Close the [MENU].

How to search for available SBAS

- 1) Open the [GNSS] menu.
- 2) Select [DGPS/SBAS], then press the **ENT** key.
- 3) Select [SBAS SEARCH], then press the **ENT** key.
- 4) Select [AUTO] or [MANUAL] as appropriate, then press the **ENT** key.
 - [AUTO] selects the highest elevated satellite available.
 - [MANUAL] requires the manual input of the three-digit satellite number.
- 5) Close the [MENU].

How to ignore SBAS satellites

- 1) Open the [GNSS] menu.
- 2) Select [DGPS/SBAS], then press the **ENT** key.
- 3) Select [IGNORED SBAS], then press the **ENT** key.
- 4) Enter the satellite number to be ignored. You can enter up to 3 satellites per network.
Press ▲ to increase the value, ▼ to decrease the value and press ► or ◀ to move the input cursor.
- 5) Close the [MENU].

How to select the DGPS beacon

- 1) Open the [GNSS] menu.
- 2) Select [DGPS/SBAS], then press the **ENT** key.
- 3) Select [BEACON SETUP], then press the **ENT** key.
- 4) Select [AUTO] or [MANUAL], then press the **ENT** key.
 - [AUTO]: The SC-70/SC-130 automatically select the beacon to use.
 - [MANUAL]: Manually input the beacon frequency and bit rate.
- 5) Close the [MENU].

2.14.4 How to Set Up RAIM

RAIM (Receiver Autonomous Integrity Monitoring) is a diagnostic feature which tests the integrity (accuracy) of the position fixing signal.

The receiver estimates position confidence using range value and detected satellite error, and displays (provided the RAIM function is active) the results as one of three levels of position confidence in the text data box of the GPS display mode only. The three levels are as follows:

- [SAFE]: GPS signal is normal. The positioning accuracy satisfies the setting value.
- [CAUTION]: RAIM accuracy cannot be calculated. (Signals from five or more GPS satellites are necessary for calculation.) The positioning accuracy does not satisfy the setting value.
- [UNSAFE]: GPS signal is abnormal, therefore the positioning accuracy is not reliable.

To use the RAIM feature, do the following:

1. Open the [GNSS] menu.
2. Select [RAIM], then press the **ENT** key.
3. Select [RAIM FOR GPS], then press the **ENT** key.
4. Select [SETTING], then press the **ENT** key. An options pop up window appears.
5. Select [ON] to enable the RAIM feature, select [OFF] to disable the RAIM feature.
6. Select [ACCURACY LEVEL], then press the **ENT** key. A numerical input pop up window appears.
7. Set the compensation for RAIM accuracy.
8. Select [ENTER], then press the **ENT** key to apply the RAIM settings, or select [CANCEL] then press the **ENT** key ignore the settings changes.
9. Close the [MENU].

2.14.5 How to set the rollover timing

The SC-70/SC-130 uses the positioning system to calculate date and time. Date and time data sent via satellite signal is reset once every few years, which can cause problems in date/time display. The rollover is used to prevent this from occurring. By setting the correct year on your SC-70/SC-130, the satellites and your system become synchronized.

1. Open the [GNSS] menu.
2. Select [RAIM], then press the **ENT** key.
3. Select [ROLL OVER], then press the **ENT** key. The [INPUT ROLL OVER] window appears.
4. Enter the current year.
Press **▲** to increase the value, **▼** to decrease the value and press **▶** or **◀** to move the input cursor.
5. Select [ENTER] to apply the new setting, select [CANCEL] to keep the current setting.
If you select [ENTER], a confirmation window appears. Select [YES] to confirm and restart the system with the new setting.

2.15 How to Set Up the I/O Menu

Besides its fundamental function of displaying position, the SC-70/SC-130 can also output various data to external equipment. Before outputting data to external equipment, first determine what data the external equipment requires. Only the necessary data should be output, to ensure that the data will be output correctly.

All data transmitted by marine electronics equipment are prefixed with a two character code, known as a “talker”. The same talker must be shared by the transmitting and receiving equipment to transmit and receive data successfully.

2.15.1 How to set up serial data output

The SC-70/SC-130 has five serial data ports which can be set up for data output.

To set up more than one port, repeat the procedure below as necessary.

1. Open the [MENU].
2. Select [I/O], then press the **ENT** key.
3. Select [DATA 1], or the appropriate data port, then press the **ENT** key.
4. Select [DATA OUTPUT], then press the **ENT** key. An options pop up window appears.
5. Select [IEC/NMEA] or [RTCM] as appropriate, then press the **ENT** key. When setting [DATA 1] to [DATA 4], [IEC/NMEA] can only be selected. [RTCM] is not selectable and displayed in gray color. Select [RTCM] in [DATA 5] to use correction data from external beacon (see subsection 2.14.3).
6. For non-IMO vessels only, select [OUTPUT FORMAT], then press the **ENT** key. An options pop up window appears. For IMO type vessels, go to step 12. [OUTPUT FORMAT] and [BAUD RATE] are fixed for IMO type vessels.
7. Select the appropriate port output format, then press the **ENT** key. The available options are: [IEC61162-1ED.5], [IEC61162-1ED.3], [NMEA V2.0], [NMEA V1.5].
8. Select [TALKER], then press the **ENT** key. An options pop up window appears.
9. Select the appropriate talker, then press the **ENT** key. The available options are listed in the table below with a brief description.

Talker	Description	Talker	Description
GN	Mixed GPS and GLONASS	GP	GPS
HE	Heading - North seeking gyrocompass	GL	GLONASS
HN	Heading - Non-north seeking gyrocompass	GA	Galileo
HC	Heading - Magnetic compass		

Note: For IMO-types, the talkers are fixed as follows.

- THD, ROTI device mode: Fixed at [HE].
 - GPS device mode: Fixed at [GP].
10. Select [BAUD RATE], then press the **ENT** key. An options pop up window appears.
 11. Select the appropriate baud rate for data transfer, then press the **ENT** key.

- Select [SENTENCES], then press the **ENT** key. The sentence setup window appears.

Currently selected port and port's baud rate

Sentence load rate

PORT1: OUTPUT SENTENCE		38400bps		LOAD RATE: 70%	
GBS	GGA	GLL	GNS	GRS	GSA
2s	2s	2s	2s	2s	2s
GST	GSV	HDG	HDM	HDT	HRM
2s	2s	2s	100ms	25ms	---
RMC	ROT	THS	YBW	VDR	VHW
2s	25ms	100ms	---	---	---
VLW	VTG	XDR	ZDA	GPatt	GPhve
---	2s	2s	1s	200ms	200ms

Sentences and their settings

- Press the arrow keys to move the selection cursor and highlight the sentence to set up, then press the **ENT** key. The cycle section of the sentence is now highlighted.
- Press ◀ or ▶ to adjust the sentence output cycle, then press the **ENT** key.
- To set up other sentences, repeat step 13 and step 14 as necessary.

Note: The sentence load rate indicates the workload required to process the sentences. When setting sentences, observe the load rate carefully and ensure it does not reach or exceed 100%.
- To apply the changes, select [ENTER], at the bottom of the sentence list, then press the **ENT** key.
To cancel any changes to the sentences, select [CANCEL], then press the **ENT** key.
- Close the [MENU].

2.15.2 How to set up LAN data output

When connecting the SC-70/SC-130 to a shipboard LAN network, perform the following procedure to set up data output.

- Open the [MENU].
- Select [I/O], then press the **ENT** key.
- Select [NETWORK], then press the **ENT** key.
- For non-IMO vessels, select [TALKER], then press the **ENT** key.
An options pop up window appears.
For IMO-type vessels, go to step 6.
- Select the appropriate talker, then press the **ENT** key. The available options are listed in the table at step 9 of section 2.15.1.

Note: For IMO-types, the talkers are fixed as follows.

 - THD, ROTI device mode: Fixed at [HE].
 - GPS device mode: Fixed at [GP].
- Referring to steps 12 through 15 of section 2.15.1, set up the sentences as appropriate.
- Select [IP ADDRESS/PORT], then press the **ENT** key. A numerical pop up window appears.
Use the following IP Address and Port combinations to show the log data in the [ETHERNET] log:

2. OPERATION

IP Address	Port	IP Address	Port
239.192.000.001	60001	239.192.000.004	60004
239.192.000.003	60003	239.192.000.008	60008
239.192.1.56*	60056*		

*: To be used only when an SRP output log is required.

8. Set the IP address and port as appropriate, select [ENTER], then press the **ENT** key.
9. Close the [MENU].

2.15.3 How to set up data sources (data input)

1. Open the [MENU].
2. Select [I/O], then press the **ENT** key.
3. Select [DATA SOURCE], then press the **ENT** key.
4. Select [HDG] (Heading) or [EXT. STW] (External Speed Thru Water), then press the **ENT** key. An options pop up window appears.
5. Referring to the table below, set the appropriate data source for [HDG] or [EXT. STW].

Menu option	Description
[INTERNAL LAN]*	Use the SC-70/SC-130 antenna as the data source. This is the default setting.
[DATA 1] to [DATA 5]	Select the serial port for position data input from an external source.
[USER PRIORITY]	<p>Set the priority for serial ports. If the signal from a port is interrupted, the SC-70/SC-130 automatically switches to the next available port (sensor), in priority order.</p> <p>The port numbers are listed on the left-side of the window.</p> <p>The priority settings, at the right-side of the window, show the highest priority sensor to the left, and the lowest priority sensor to the right.</p> <p>In the example figure, the priority order is set as follows: 1→6→4→2→5→3.</p> <p>Note: [1: INTERNAL LAN] is fixed as the highest priority data source.</p>

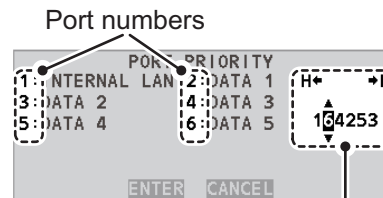

Priority settings
 Press ▲ or ▼ to change port.
 Press ◀ or ▶ to move the cursor.

*: The [INTERNAL LAN] menu option is not available for [EXT. STW].

6. Close the [MENU].

2. OPERATION

[ETHERNET] - LAN data

Note: If the IP address & port combination is not a recognized combination (see section 2.15.2), the [ETHERNET] log screen appears blank.

Data source's IP address Destination broadcast address and port

MENU	PRECISION				
HDG	01.495°	ROT	+000.858° /min	GP-S3D	NORMAL
IEC	6	162-450			NO USB
1	172.31.18.22	→	SATD(239.192.0.3:60003)		
	\s:HE0002,n:258*01\SHETHS,180.5,A*21<0D><0A>				
2	172.31.18.22	→	SATD(239.192.0.3:60003)		
	\s:HE0002,n:259*00\SPFEC,GPatt,180.5,-2.2,-23.4*71<0D><0A>				
3	172.31.18.22	→	SATD(239.192.0.3:60003)		
	\s:HE0002,n:260*0A\SPFEC,GPhve,0.024,A*39<0D><0A>				
SHOW DETAIL BACK MENU CLOSE (ENT) LONG REFRESH					

Packet summary
Press ▲ or ▼ to select a packet. Selection is highlighted in gray.

Select a packet, then press ► to view the packet details.

MENU	PRECISION				
HDG	002.320°	ROT	+000.816° /min	GP-S3D	NORMAL
172.31.18.22 → SATD(239.192.0.3:60003)					
\s:HE0002,n:869*09\SHEHDT,181.7,T*20<0D><0A>					
SHOW DETAIL BACK MENU CLOSE (ENT) LONG REFRESH					

[CAN] - NMEA2000 network data

PGN destination's CAN address (broadcast to 255)

PGN source's unique CAN address

CAN BUS : 250kbps				NO USB
SRC	DST	PGN	PGN name	
000	255	127251	Rate of Turn	
000	255	127252	Heave	
000	255	127257	Attitude	
000	255	127258	Magnetic Variation	
000	255	129025	Position	
000	255	129026	COG & SOG Rapid Update	
000	255	129029	GNSS Position Date	
SHOW DETAIL INFORMATION BACK MENU CLOSE				

USB status
No USB = No external flash memory connected.
SAVING = Saving log data to external flash memory.
STOP SAVING = Flash memory connected, no log data currently being saved.

Select a PGN, then press ► to view the PGN details.

PGN and name

PGN details

60928	ISO Address Claim
Unique Number	: 1
Manufacture Code	: 1855
Device Instance Lower	: 1
Device Instance Upper	: 1
Device Function	: 1
Reserved	: -
Device Class	: 1
System Instance	: 1
SHOW DETAIL INFORMATION BACK MENU CLOSE	

[LAN ERROR LOG]

The [LAN ERROR LOG] counts LAN errors, filing the errors in one of six error groups. The table below shows the error groups along with possible causes for their errors.

LAN ERROR COUNTER		
1	INCORRECT SENTENCE	0
2	TAG BLOCK FRAMING ERROR	0
3	TAG SYNTAX ERROR	0
4	TAG BLOCK CHECKSUM ERROR	0
5	INCORRECT TAG BLOCK	0
6	INVALID HEADER	0

Error	Possible cause(s)
[INCORRECT SENTENCE]	<ul style="list-style-type: none"> • Sentence in TAG block has an error. • CHECKSUM error. • Sentence does not meet NMEA0183 standards.
[TAG BLOCK FRAMING ERROR]	Unexpected transmission start/stop in TAG block.
[TAG SYNTAX ERROR]	<ul style="list-style-type: none"> • One or more errors in TAG block. • Data length is too long or too short. • Delimiter is in use. • Use of incorrect characters.
[TAG BLOCK CHECKSUM ERROR]	TAG block has one or more CHECKSUM errors.
[INCORRECT TAG BLOCK]	One or more instances of the following: <ul style="list-style-type: none"> • Incorrect talker used. • Incorrect SFI used. • Incorrect parameters (g, s, p, n, t) used.
[INVALID HEADER]	One or more instances where the following are not included: <ul style="list-style-type: none"> • UdPbC • RaUdP • RrUdP

Press and hold the **ENT** key to clear the [LAN ERROR LOG].

2.15.5 How to restart heading output

In cases where the heading signal is lost or interrupted, the SC-70/SC-130 can restart signal output. There are two methods, [AUTO] and [MANUAL].

1. Open the [MENU].
2. Select [I/O], then press the **ENT** key.
3. Select [MISCELLANEOUS], then press the **ENT** key.
4. Select [HDG OUTPUT RESTART], then press the **ENT** key. An options pop up window appears.
5. Select [AUTO] or [MANUAL] as appropriate, then press the **ENT** key.
 - [AUTO] : Automatically restart heading output when the signal is restored.
 - [MANUAL] : When the heading signal is lost, an alert message and audible alert are released. If the heading signal output is restored, the message "HDG DATA OUTPUT HAS BEEN RESTARTED." is shown. Press the **ENT** key to resume the signal output.

Note: The default setting is [AUTO]. Select [MANUAL] depending on connected equipment.

6. Close the [MENU].

2.15.6 How to use backup HDG output

Note: This feature is NOT available for vessels set as [RUSSIA] and [MERCHANT] at installation. For Russian merchant vessels, this feature is fixed to [OFF] and related settings are not shown in the menu.

The SC-70/130 can use the heading from the last time of operation as a backup immediately after the power is turned on. The backup heading is used until a new heading is fixed. You can activate or deactivate this feature with the following procedure.

1. Open the [MENU].
2. Select [I/O], then press the **ENT** key.
3. Select [MISCELLANEOUS], then press the **ENT** key.
4. Select [REPEATER BACKUP HDG OUTPUT], then press the **ENT** key.
5. Select [ON] or [OFF] as required.
[ON]: Uses dead reckoning heading until a heading is fixed.
[OFF]: Disables dead reckoning heading until a heading is fixed.
6. Close the [MENU].

2.15.7 How to change the speed reference (Non-IMO types only)

The speed reference is used in the VHW sentence for speed data output to external equipment.

1. Open the [MENU].
2. Select [I/O], then press the **ENT** key.
3. Select [MISCELLANEOUS], then press the **ENT** key.
4. Select [STW] (Speed Through Water), then press the **ENT** key. An options pop up window appears.
5. Select [VECTOR] or [SCALAR] as appropriate, then press the **ENT** key.
[VECTOR] : Speed is calculated based on own ship vector.
[SCALAR] : Speed is calculated based on SOG (Speed Over Ground).
6. Close the [MENU].

2.15.8 How to hold course at low speeds

To hold the same course when speed is under 0.2 kn, do the following procedure.

1. Open the [MENU].
2. Select [I/O], then press the **ENT** key.
3. Select [MISCELLANEOUS], then press the **ENT** key.
4. Select [COG HOLD (LOW SPD)] (Course Over Ground at low speed), then press the **ENT** key. An options pop up window appears.
5. Select [ON] or [OFF] as appropriate, then press the **ENT** key.
[ON]: COG is not updated when speed is under 0.2 kn.
[OFF]: COG is updated regardless of ship's speed.
6. Close the [MENU].

2.16 SENSOR Menu

The [SENSOR] menu contains settings for the connected sensors. Some settings in this menu require service level access and are not changeable by the user.

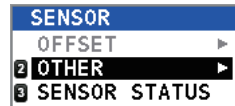

To access this menu, open the [MENU], then select [SENSOR].

Note: The [OFFSET] menu is reserved for technical personnel only.

2.16.1 OTHER menu

1. Open the [MENU].
2. Select [SENSOR], then press the **ENT** key.
3. Select [OTHER], then press the **ENT** key.

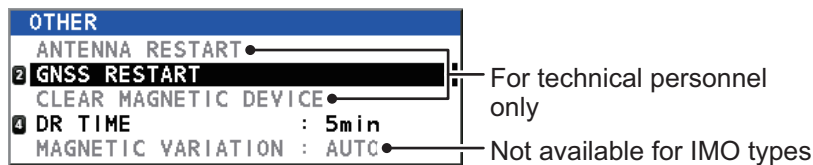

4. Select the appropriate menu item, then press the **ENT** key.
 - [GNSS RESTART]: Restarts the GNSS cores. A confirmation message appears; select [YES] to reset the GNSS cores or select [NO] to cancel the reset.
 - [DR TIME]: Set the Dead Reckoning time. Available options are [1 min], [2 min], [3 min], [4 min] and [5 min] (default setting). Select the required time, then press the **ENT** key.
 - [MAGNETIC VARIATION]: Select whether to adjust for magnetic variation automatically ([AUTO]) or manually ([MANUAL]). If you selected [MANUAL], the [INPUT MAGNETIC VARIATION] pop up window appears. Enter the variation amount, select [ENTER], then press the **ENT** key.

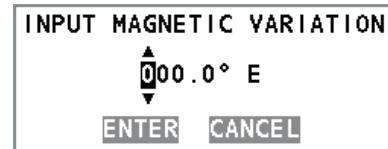

Note: The [MAGNETIC VARIATION] menu item is not available for IMO types.

5. Close the [MENU].

2.16.2 SENSOR STATUS menu

You can check the status of your sensors from this menu. Select [SENSOR STATUS] from the [SENSOR] menu to show the window below.

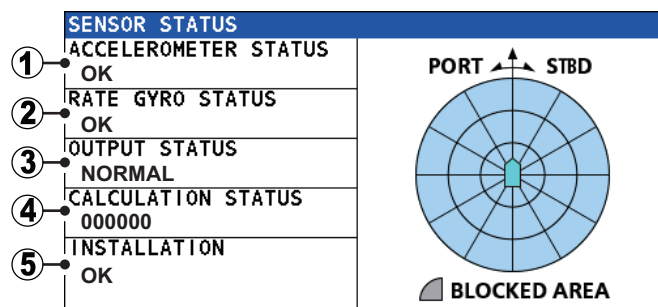

2. OPERATION

Possible statuses for each item are listed in the table below.

No.	Possible status
1	<ul style="list-style-type: none">• "OK": Sensor is functioning normally.• "NG (axis)": The sensor is not functioning normally on the axis shown. For example, "NG X,Y" means the X and Y axis are not functioning normally.
2	<ul style="list-style-type: none">• "OK": Sensor is functioning normally.• "NG (axis)": The sensor is not functioning normally on the axis shown. For example, "NG X,Y" means the X and Y axis are not functioning normally.
3	<ul style="list-style-type: none">• "NORMAL": Sensor is functioning normally.• "DR": Dead Reckoning in use.• "OUTPUT STOPPED": Sensor output has stopped.• "NOT EXPECTED": An unexpected error has occurred.
4	Hexadecimal code is displayed.
5	<ul style="list-style-type: none">• "OK": Sensor is functioning normally.• "BLOCKED": One or more sensors' line of view is blocked.• "VIBRATED": One or more sensors are in a location which is subject to excessive vibrations.

2.17 SYSTEM Menu

The SYSTEM menu contains settings for your SC-70/ SC-130 system. To access this menu, open the [MENU] then select [SYSTEM].

Note 1: The [USB FLASH DRIVE] menu item is selectable only when a USB Flash Memory is connected to the Junction Box.

Note 2: The [NETWORK] menu item is reserved for technical personnel only and requires key code level access from the [SERVICE] menu.

The SFI settings should be done at installation by the service technician.

The SFI must be in the format "ccxxxx" (six characters), where "cc" is the talker (default for this equipment is "HE"). The "xxxx" portion of the SFI has a setting range of 0001 to 9998. To change these settings, consult your installation technician or your local FURUNO dealer.

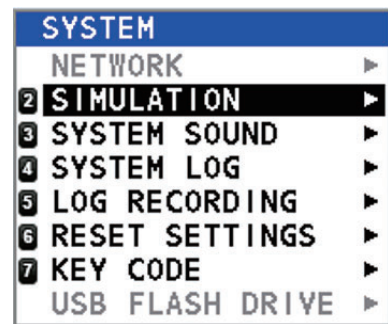

2.17.1 Simulation mode

Note: For vessels set as [RUSSIA] and [MERCHANT] at installation, this feature is only available for FURUNO service technicians.

Simulation mode uses data from the internal memory to provide a simulation of the systems functions. To use the simulation mode, several settings are required, as listed in the procedure below.

1. Open the [MENU].
2. Select [SYSTEM], then press the **ENT** key.

3. Select [SIMULATION], then press the **ENT** key.

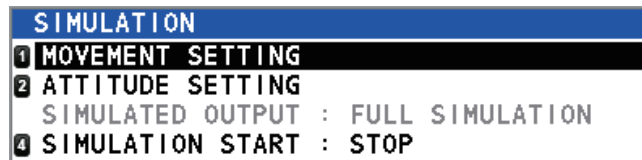

4. Select [MOVEMENT SETTING], then press the **ENT** key. The [SIMULATION(MOVEMENT) SETTING] window appears.

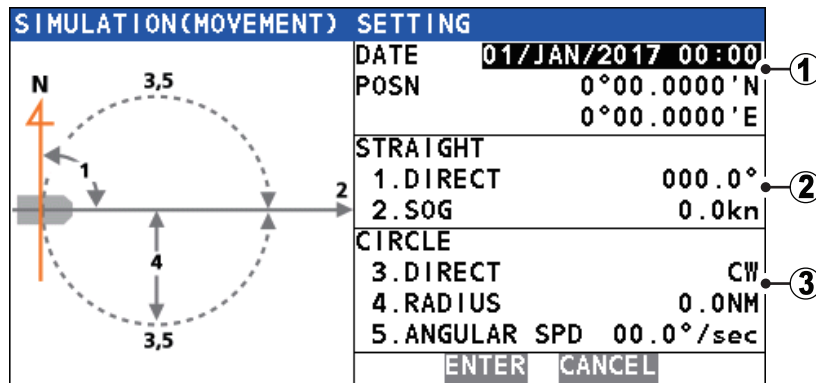

No.	Menu item	Description
1	<ul style="list-style-type: none"> [DATE] [POSN] 	<ul style="list-style-type: none"> Sets the date for the simulation. Sets the position (coordinates) for the simulation.
2	<ul style="list-style-type: none"> [STRAIGHT] [DIRECT] [SOG] 	<ul style="list-style-type: none"> Sets a simulated course in a straight line. Sets the heading for the simulation. Sets the SOG (Speed Over Ground) for the simulation.
3	<ul style="list-style-type: none"> [CIRCLE] [DIRECT] [RADIUS] [ANGULAR SPD] 	<ul style="list-style-type: none"> Sets a simulated course in a circle. Sets the direction of the circle. ([CW]: Clockwise; [CCW]:Counter-clockwise) Sets the radius of the circle, in Nautical Miles. Sets the speed at which to turn during the simulation.

5. Referring to the figure and table above, select a parameter to set for the simulation, then press the **ENT** key. A settings pop up window appears.
6. Press the CursorPad to move the cursor and adjust the settings for the selected parameter. When the settings for the selected parameter are complete, select **ENTER**, at the bottom of the window, then press the **ENT** key. The [SIMULATION(MOVEMENT) SETTING] window appears.
7. When all parameter settings are complete, select **ENTER**, at the bottom of the [SIMULATION(MOVEMENT) SETTING] window, then press the **ENT** key. The [SIMULATION] menu appears.

2. OPERATION

- Select [ATTITUDE SETTING], then press the **ENT** key. The [SIMULATION(ATTITUDE) SETTING] window appears.

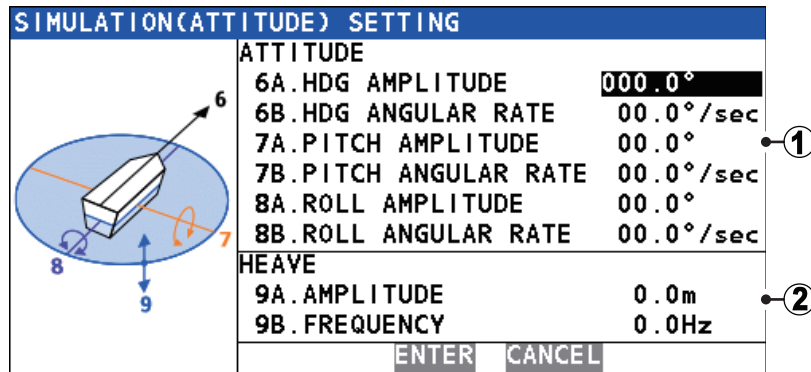

No.	Menu item	Description
1	[ATTITUDE] • [HDG AMPLITUDE] • [HDG ANGULAR RATE] • [PITCH AMPLITUDE] • [PITCH ANGULAR RATE] • [ROLL AMPLITUDE] • [ROLL ANGULAR RATE]	Attitude settings for heading, pitch and roll. • Sets the heading angle. • Sets the rate at which the heading changes. • Sets the pitch angle. • Sets the rate at which the pitch changes. • Sets the roll angle. • Sets the rate at which the roll changes.
2	[HEAVE] • [AMPLITUDE] • [FREQUENCY]	Settings for heave. • Sets the distance for heave. • Sets the frequency (Hz) for heave.

- Referring to the figure and table above, select a parameter to set for the simulation, then press the **ENT** key. A settings pop up window appears.
- Press the CursorPad to move the cursor and adjust the settings for the selected parameter. When the settings for the selected parameter are complete, select **ENTER**, at the bottom of the window, then press the **ENT** key. The [SIMULATION(ATTITUDE) SETTING] window appears.
- When all parameter settings are complete, select **ENTER**, at the bottom of the [SIMULATION(ATTITUDE) SETTING] window, then press the **ENT** key. The [SIMULATION] menu appears.
- Select [SIMULATION], then press the **ENT** key. The start/stop options window appears.
- Select [START]. A confirmation window appears. Select [YES] to start the simulation, or select [NO] to cancel.
If you select [YES], the system restarts. When the restart is completed, the system operates in simulation mode and the simulation indicator is shown at the top-right of the display.

How to stop the simulation

You can stop the simulation at any time from the menu.

- Referring to the steps 1 to 3 of the above procedure, open the [SIMULATION] menu.
- Select [SIMULATION], then press the **ENT** key. The start/stop options window appears.

3. Select [STOP]. A confirmation window appears. Select [YES] to start the simulation, or select [NO] to cancel.
If you select [YES], the system restarts. When the restart is completed, the system operates in normal mode and the simulation indicator is not shown at the top-right of the display.

2.17.2 SYSTEM SOUND menu

When a key is pressed the system releases a “key beep”. You can turn the key beeps on or off, to suit your preference.

1. Open the [MENU].
2. Select [SYSTEM], then press the **ENT** key.
3. Select [SYSTEM SOUND], then press the **ENT** key. The [SYSTEM SOUND] menu appears.



4. [KEY BEEP] is already selected, press the **ENT** key. The settings options window appears.
Note: The [NOTIFICATION SOUND] menu item is reserved for technical personnel and is not selectable.
5. Select [ON] or [OFF] as appropriate, then press the **ENT** key.
6. Close the [MENU].

2.17.3 SYSTEM LOG menu

If a USB Flash Memory is connected to the Junction Box, you can save a system log file to the USB. To save a log file, do the following:

1. Open the [MENU].
2. Select [SYSTEM], then press the **ENT** key.
3. Select [SYSTEM LOG], then press the **ENT** key. The [SYSTEM LOG] menu appears.



4. [RECORDING] is already selected, press the **ENT** key. The settings options window appears.
Note: The [LOG LEVEL] menu item is reserved for technical personnel and is not selectable.
5. Select [ON] or [OFF] as appropriate, then press the **ENT** key.
6. Close the [MENU].

2.17.4 How to save a sensor log

You can save a log file for your GNSS, sensor or offline (both GNSS and sensor) data.

1. Open the [MENU].
2. Select [SYSTEM], then press the **ENT** key.
3. Select [LOG RECORDING], then press the **ENT** key. The [LOG RECORDING] menu appears.
4. Select [LOG TYPE], then press the **ENT** key. An options pop up window appears.
5. Select the appropriate option, then press the **ENT** key.
 - [OFF]: No log data is saved.
 - [GNSS ONLY]: Only GNSS core log data is saved.
 - [SENSOR ONLY]: Only sensor log data is saved.
 - [OFFLINE DATA]: Both GNSS and sensor log data is saved as offline data.
6. Select [DESTINATION], then press the **ENT** key. An options pop up window appears.
7. Select the appropriate option, then press the **ENT** key.
 - [USB]: Log data is saved to the USB Flash Memory.
 - [MP]: Log data is saved to the device connected via the Remote Maintenance port.
8. Close the [MENU].



2.17.5 How to clear display settings and GPS memory

You can reset the display settings and clear the GNSS (GPS) memory.

1. Open the [MENU].
2. Select [SYSTEM], then press the **ENT** key.
3. Select [RESET SETTING], then press the **ENT** key. The [RESET SETTINGS] menu appears.
4. Select the appropriate option, then press the **ENT** key. A confirmation window appears.

Note: The [FACTORY DEFAULT] and [CLEAR ETHERNET SETTING] menu items are reserved for technical personnel and are not selectable.
5. Select [YES] to reset the settings, or [NO] to cancel.



2.17.6 How to restore IEC61162-450 default ethernet settings

You can reset the ethernet settings to the IEC61162-450 defaults, listed below.

- IP address: 192.168.0.1
- Sub-network mask: 255.255.255.0
- Default gateway: 0.0.0.0

To restore the IEC61162-450 default settings, do the following:

1. Open the [MENU].
2. Select [SYSTEM], then press the **ENT** key.
3. Select [RESET SETTINGS], then press the **ENT** key.
4. Select [CLEAR ETHERNET SETTING], then press the **ENT** key.
Note: The [FACTORY DEFAULT] and [CLEAR ETHERNET SETTING] menu items are reserved for technical personnel and are not selectable.
5. Select [YES] to reset the settings, or [NO] to cancel.

2.18 ROTI Display Operations (RD-50/RD-20, option)

The optional RD-50/RD-20 Remote Display Unit is available as a remote display for ROTI data only. Operations and settings for the RD-50 are outlined in the RD-50 operator's manual (OME-44530-x; x denotes the manual version), supplied with the RD-50.

2. OPERATION

This page is intentionally left blank.

3. NMEA2000 I/O DATA

The SC-70/130 handle the NMEA2000 I/O data PGNs listed below. The LEN (Load Equivalency Number) is 1. LEN is the amount of current a device draws from the NMEA2000 network. 1 LEN = 50 mA.

3.1 Input Data

PGN	Name	Remarks			
059392	ISO Acknowledgement				
059904	ISO Request	Request for PGN output of Note1 in the output data table in section 3.2.			
060160	ISO Transport Protocol, Data Transfer				
060416	ISO Transport Protocol, Connection Management - BAM Group Function	BAM = Broadband Announce Message			
060928	ISO Address Claim				
061184	Self Test Group Function				
065240	ISO Commanded Address				
126208	NMEA-Request Group Function	Request for PGN output of Note 1, 2 and 3 in the output data table on the page 2, also interval change for regular PGN output in the output data table in section 3.2.			
	NMEA-Command Group Function	Standard PGNs and their changeable fields			
		PGN	Name	Field	Name
		060928	ISO Address Claim	#3	Device Instance Lower
				#4	Device Instance Upper
				#8	System Instance
		126998	Configuration Information	#1	Installation Description, Field 1
#2	Installation Description, Field 2				
#3	Installation Description, Field 3				
126996	Product Information				

3

3.2 Output Data

PGN	Name	Remarks
059392	ISO Acknowledgement	- Output for rejection of output request by ISO Request.
059904	ISO Request	
060928	ISO Address Claim	Note 1, 2 - Transmission at the time of address generation. - Output for receiving the output request by ISO Request.
061184	Self Test Group Function	- - Proprietary PGN - Output for receiving the Self Test Group Function

3. NMEA2000 I/O DATA

PGN	Name	Remarks	
065280	Heave	100 ms	- Proprietary PGN
126208	NMEA-Acknowledge Group Function	-	
126464	PGN List - Transmit PGN's Group Function	Note 1, 2	
	PGN List - Received PGN's Group Function	Note 1, 2	
126992	System Time	1000 ms	
126993	Heart Beat	60000 ms	
126996	Product Information	Note 1, 2	
126998	Configuration Information	Note 1, 2	
127250	Vessel Heading	100 ms	
127251	Rate of Turn	100 ms	
127252	Heave	100 ms	
127257	Attitude	100 ms	
127258	Magnetic Variation	1000 ms	
129025	Position, Rapid Update	100 ms	
129026	COG & SOG Rapid Update	250 ms	
129029	GNSS Position Data	1000 ms	
129033	Local Time Offset	Note 1, 2, 3	
129044	Datum	10000 ms	
129291	Set & Drift, Rapid Update	1000 ms	
129539	GNSS DOPs	1000 ms	
129540	GNSS Sats in View	1000 ms	
129545	GNSS RAIM Output	1000 ms	
129547	GNSS Pseudo Range Error Statistics	Note 1, 2	
130310	Environmental Parameters - DEPRECATED	500 ms	
130312	Temperature - DEPRECATED	2000 ms	
130314	Actual Pressure	2000 ms	
130316	Temperature, Extended Range	2000 ms	
130577	Direction Data	1000 ms	
130578	Vessel Speed Components	250 ms	
130822	Unit Division Code	Note 2	- Proprietary PGN
130823	Browser Control Status	Note 2	- Proprietary PGN
130842	Six Degrees of Freedom Movement	Note 2	- Proprietary PGN
130843	Heel Angle & Roll Information	100 ms	- Proprietary PGN
130845	Multi Sats In View Extended	Note 2, 3	- Proprietary PGN
130846	Motion Sensor Status Extended	Note 2, 3	- Proprietary PGN

Note 1: PGN to output independently when "PGN: 059904" or "PGN: 126208" requested.

Note 2: PGN to output independently when "PGN: 126208" requested.

Note 3: PGN to output regularly when "PGN: 126208" requested.

4. MAINTENANCE, TROUBLE-SHOOTING

4.1 Preventative Maintenance

Regular maintenance is necessary to maintain performance. A monthly maintenance program should be established and should at least include the items listed in the table below.

Item	Check point
Connectors	Check that all connectors on the rear panel of the Junction Box and display unit are firmly connected.
Cabling	Check cabling for damage. Replace if damaged.
Ground terminal	Check the ground terminal on the display unit and Junction Box for rust. Clean if necessary.
Ground wire	Check that the ground wire on the display unit and Junction Box is firmly fastened.
Display unit, Junction Box.	Dirt and dust should be removed from units with a soft, dry cloth. For the LCD, wipe it carefully to prevent scratching, using tissue paper and an LCD cleaner. To remove dirt or salt deposits, use an LCD cleaner, wiping slowly with tissue paper so as to dissolve the dirt or salt. Change paper frequently so the salt or dirt will not scratch the LCD. Do not use solvents such as thinner, acetone or benzene for cleaning any unit; they can remove paint and marks and deform the equipment.
Exposed nuts and bolts and sealant compound on cable gland of antenna unit (every three or six months)	<ul style="list-style-type: none"> • Check for corroded or loosened nuts and bolts. If necessary, clean and repaint them thickly. Replace them if heavily corroded. • Check for cracks and peeling in sealing compound on cable gland. • Sealing compound can be used instead of paint. Apply a small amount of grease between nuts and bolts for easy removal in future. • Apply sealing compound to minor cracks or peeling. If the problem is severe, completely remove sealant then reapply.

4

4.2 Replacement of Fuse

The Junction Box (SC-701) contains fuses which protects the equipment from overvoltage, reverse polarity and equipment fault. If power cannot be turned on, check if the fuse has blown.

Only a qualified technician should change the fuse, contact your dealer and quote the fuse details listed below.



WARNING

Use the proper fuse.

Use of a wrong fuse can damage the equipment or cause fire.

Used for	Fuse type	Code No.
SC-701	FBGO-A 125V 3A PBF	000-155-850-10
SC-702	FGMB 125V 0.3A PBF	000-176-821-10

4.3 Basic Troubleshooting

This section provides basic troubleshooting which the user may follow to restore normal operation. If the problem is not rectified, contact your dealer for advice.

Symptom	Possible cause and remedy
Cannot turn the power on.	Power cables may be damaged or corroded. Check the cables for corrosion or damage; replace as necessary.
	Power cable may be loose or disconnected. Check the cable connections are fastened firmly.
	Blown fuse. Check the fuses. If blown, contact your dealer for replacement.
	Ship battery may have low voltage. Check that the battery voltage is within rating.
Display screen is blank.	Brilliance level may be too low. Press the BRILL key to adjust the brilliance.
No position fix.	Antenna cable may be loose or disconnected. Check the antenna cable is fastened firmly.
	Unable to see more than two satellites. Check that there are no large obstructions preventing a clear view to the sky.
	GPS needs to be restarted. From the main menu, select [SYSTEM]→[RESET SETTINGS]→[CLEAR GNSS]→[YES].
Large error between actual and indicated location.	Positioning system may be incorrect or sensor is faulty. From the main menu, select [GNSS]. Confirm that the settings for [POSN. SYSTEM] and [MODE] are correct.
Heading indication changes randomly when the vessel is anchored or does not change when the vessel is moving.	Antenna may be poorly located or unable to obtain a positioning fix. <ol style="list-style-type: none"> 1) Check that the antenna has a clear view to the sky. 2) Check that the installation location is not subjected to excessive vibrations. 3) Check that there the antenna is not subject to interference from nearby equipment
	Sensor may be faulty. <ol style="list-style-type: none"> 1) Check the sensor status from the [SENSOR] menu. 2) Run a [DIAGNOSTIC TEST] from the [MAINTENANCE] menu. If one or more sensors are faulty, contact your dealer for advice.
Data output from the SC-70/SC-130 does not appear on external equipment.	Connection between the SC-70/SC-130 and external equipment is loose or damaged. Check connection, replace or reconnect/refasten as necessary.
	Output settings are incorrect. From the main menu, select [I/O], then select the output port. Confirm that the settings are correct.
	Sensor may be faulty. <ol style="list-style-type: none"> 1) Check the sensor status from the [SENSOR] menu. 2) Run a [DIAGNOSTIC TEST] from the [MAINTENANCE] menu. If one or more sensors are faulty, contact your dealer for advice.
	External equipment not set correctly. <ol style="list-style-type: none"> 1) Check the external equipment data input settings. 2) Output data and input data connection should set as follows: SC70/SC-130=TD-A ←connection→ external equipment=RD-A SC70/SC-130=TD-B ←connection→ external equipment=RD-B
The external equipment can not received NMEA2000 data from SC-70/SC-130.	Turn on the NMEA2000 network before the SC-70/SC-130. If the SC-70/SC-130 is turned on before the NMEA2000 network, reboot the SC-70/SC-130.

4.4 Maintenance Menu

The [MAINTENANCE] menu contains items such as diagnostic tests, unit information and other maintenance-specific menus. You can also save or load your user settings from this menu.

To access the [MAINTENANCE] menu, open the [MENU], then select [MAINTENANCE]. The [MAINTENANCE] menu appears.



4.4.1 How to find unit information

You can view your equipment's details from the [INFORMATION] menu. The displayed details include handy information such as program numbers and serial numbers.

1. From the [MAINTENANCE] menu, select [INFORMATION], then press the **ENT** key.
2. Select the unit whose information you want to view, then press the **ENT** key.
3. Select the part of the unit whose information you want to view, then press the **ENT** key.

Items shown in gray are either not selectable, or have no information to view. Press ▲ or ▼ to scroll through the displayed information.

4.4.2 How to Backup User Settings

If a USB Flash Memory is connected at installation (see section 1.5.5), the SC-70/SC-130 can import or export user settings via external USB flash memory. This allows you to apply the same settings to multiple units, or recover settings if they are accidentally changed.

Note: The menu is inoperable while importing or exporting settings. Also, the import/export procedure cannot be stopped once it starts. For safety, conduct these operations while moored safely.

To import or export settings, do the following:

1. Open the [MENU].
2. Select [MAINTENANCE], then press the **ENT** key.
3. Select [IMPORT/EXPORT], then press the **ENT** key.
4. Select [IMPORT USER SETTINGS] or [EXPORT USER SETTINGS] as appropriate, then press the **ENT** key. A confirmation pop up window appears.
5. Select [YES] to import/export the user settings, [NO] to cancel the import/export. If [YES] is selected, a progress widow appears, showing the overall progress of the import/export.
If an error occurs during the import/export, an error message appears. Referring to the table on the following page, take the appropriate action.

Error message	Meaning	Recommended action
"NO USB!"	No USB flash memory is connected to this unit.	Press the MENU ESC key to close the pop up. Check the connection. If a flash memory is connected, the USB connector/cable may be damaged, contact your dealer.
"ERROR DETECTED IN SETTINGS TRANSFER! RESTORING PREVIOUS SETTINGS."	Data transfer to/from the USB flash memory was interrupted/ stopped. This unit will restore the settings used prior to import.	Press the ACK key to close the pop up and start restoring the settings.
"NOT ENOUGH SPACE ON USB."	USB flash memory does not have enough space to save the settings.	Delete unnecessary files from the USB or use a USB with sufficient memory.
"NO FILE FOUND ON USB."	There is no settings file saved on the connected USB.	Connect the correct USB.
"OTHER BACKUP PROCESS IS RUNNING."	Import/export was attempted while a separate backup (or log) is in progress.	Wait for the other backup/log to complete, then try again.

6. When the import/export is complete the progress window is replaced with a pop up window displaying the message "IMPORT COMPLETE" or "EXPORT COMPLETE".
7. Press the **ENT** key. The last used display screen appears.
8. Open the [MENU].
9. Select [SYSTEM], then press the **ENT** key.
10. Select [USB FLASH DRIVE], then press the **ENT** key.
11. Select [UNMOUNT], then press the **ENT** key.
12. Close the [MENU].

How to remove the USB Flash Memory

To remove the USB Flash Memory, open the MENU, then select [SYSTEM] → [USB FLASH DRIVE] → [UNMOUNT]. When the process is completed, the message "YOU CAN REMOVE THE USB SAFELY" appears. Remove the USB Flash Memory.

4.5 Diagnostic Tests

The [DIAGNOSTICS] menu has several diagnostic tests which may help find the cause of a problem. To access the [DIAGNOSTICS] menu, do the following:

1. Press the **MENU ESC** key to access the menu.
2. Select [MAINTENANCE], then press the **ENT** key.
3. Select [DIAGNOSTICS], then press the **ENT** key.

The following tests are available:

[MEMORY] TEST	: See section 4.5.1.
[KEY TEST]	: See section 4.5.2.
[LCD TEST]	: See section 4.5.3.
[AUTOMATIC TEST]	: See section 4.5.4.
[MANUAL TEST]	: For technical personnel only.
[SOUND TEST]	: See section 4.5.5.

4. Select the appropriate test, then press the **ENT** key.
5. Close the [MENU].

4.5.1 Memory test

The [MEMORY] test checks RAM, ROM, USB, LAN ports and data ports for the Junction Box (SC-701), the display unit (SC-702) and the antenna unit (SC-703/SC-1303).

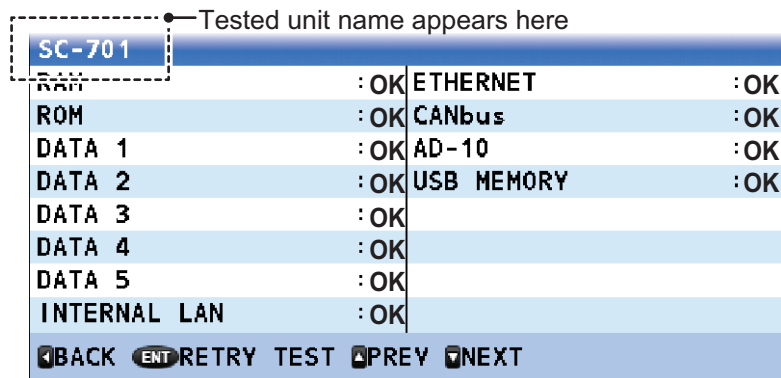

Press the ▲ or ▼ to cycle through the test result for each tested unit.

Press the **MENU ESC** key to close the results screen and return to the [SELF TEST] menu, or press the **ENT** key to repeat the test.

4.5.2 Keyboard test

The [KEYBOARD] test checks that the keys are functioning correctly.

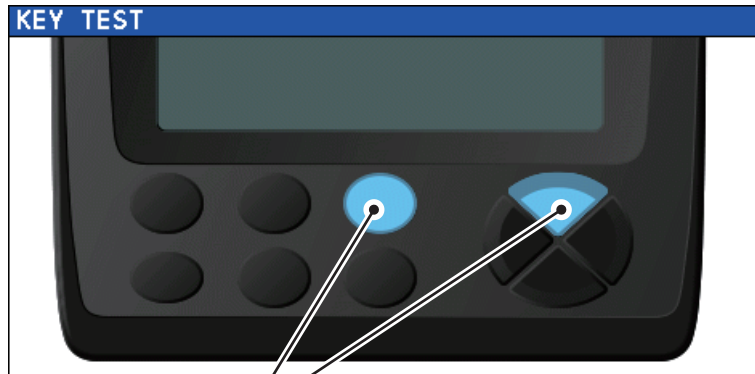

Keys are highlighted when the corresponding key is pressed. Press the key again and the highlight is removed.

If a key is malfunctioning, contact your dealer.

To close this test screen, press the **MENU ESC** key three times.

4.5.3 LCD test

The [TEST PATTERN] test checks the LCD display colors and patterns. This test changes the display color and shows patterns.

The test start screen shows operational guidance for the LCD test, as shown in the figure below.

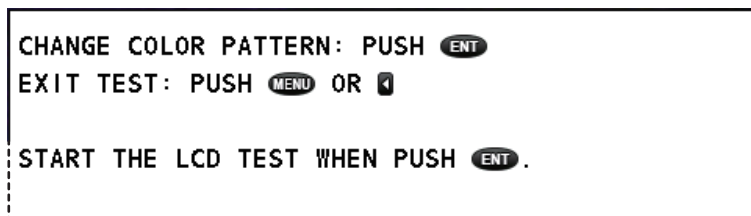

Press the **ENT** key to continue the test, or press the **MENU ESC** key to abort the test.

The colors and patterns appear in the order shown below.

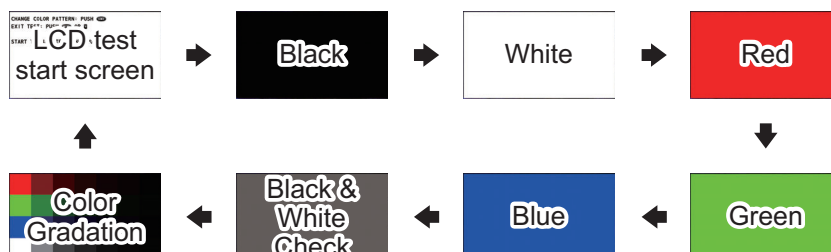

If the colors are not displayed correctly, or show signs of LCD damage, contact your dealer.

4. MAINTENANCE, TROUBLESHOOTING

This page is intentionally left blank.

APPENDIX 1 MENU TREE

Main menu

- | 1 DISPLAY **Bold Italic**: Default
- | 2 GNSS
- | 3 ALERT
- | 4 MAINTENANCE
- | 5 I/O
- | 6 SENSOR ***: Requires key code access.**
- | 7 SYSTEM **For technical personnel only.**
- | 8 SERVICE*

1 DISPLAY

- | 1 BKGD COLOR (**WHITE**, BLACK)
- | 2 UNIT
 - | 1 DISTANCE (**NM**, KM, SM)
- | 3 SMOOTHING
 - | 1 VTG (**0000s** to 9999s)
 - | 2 6DoF (**0000s** to 9999s)
 - | 3 OS SPEED(X,Y)***6** (**0000s** to 9999s) ***6: Non-IMO only, fixed for IMO**
 - | 4 ROT (00s to 30s, default: **04s**)
- | 4 DECIMAL ROUNDING
 - | 1 VTG (**1**, 2, 3)
 - | 2 VBW***6** (**1**, 2, 3)
 - | 3 HDG (**1**, 2, 3)
 - | 4 ROLL, PITCH (**1**, 2, 3)
- | 5 DATUM (**WGS84**, WGS72, PZ90, CK42, CK95, OTHERS)
- | 6 TRIP SETTING***6**
 - | 1 CLEAR
- | 7 TIME
 - | 1 LOCAL TIME (**UTC**, LOCAL)
 - | 2 SUMMER TIME (**ON**, **OFF**)
- | 8 LANGUAGE
 - | 1 **ENGLISH**
 - | 2 日本語 (Japanese)

2 GNSS

- | 1 POSN. SYSTEM
 - | 1 GPS
- | 2 MODE (**AUTO(2D/3D)**, 2D) (For technical personnel only. Do not use.)
- | 3 POSN. CONDITION
 - | 1 QZSS (**ON**, OFF)
 - | 2 ELEVATION MASK (**5°** to 90°) (For technical personnel only. Do not use.)
 - | 3 IGNORED GNSS
 - | 1 QZSS
 - | 2 GPS
 - | 3 GLONASS
 - | 4 GALILEO
- | 4 DGPS/SBAS
 - | 1 DIFFERENTIAL (GNSS, GNSS+SBAS, GNSS+EXTERNAL, **AUTO**)
 - | 2 SBAS SEARCH (**AUTO**, MANUAL)
 - | 3 IGNORED SBAS
 - | 4 BEACON SETUP (**AUTO**, MANUAL) ***7: Available on when Alert Mode is set to Legacy.**
- | 5 RAIM
 - | 1 RAIM FOR GPS
 - | 1 SETTING (**ON**, OFF)
 - | 2 ACCURACY LEVEL (001m to 999m, default: **100m**)
- | 6 ROLL OVER (2000 to 2099, default: **2016**)
- | 7 SETUP***1** ***1: Requires key code access. For service personnel only.**

3 ALERT

- | 1 ALERT LIST
- | 2 REMOTE ACK I/F (**ACK**, BUZZER STOP)***7**
- | 3 SOUND (OFF, SHORT, **LONG**, CONTINUOUS)***5** ***5: Non-IMO types only. Fixed for IMO types.**
- | 4 ALERT LOG

Continued on page AP-2

APPENDIX 1 MENU TREE

Continued from page AP-1

4 MAINTENANCE

- 1 INFORMATION
 - 1 DISPLAY UNIT
 - 1 MAIN PCB
 - 2 LCD
 - 2 ANTENNA UNIT
 - 1 MAIN PCB
 - 2 SUB IMU (Not available where there is no SUB_IMU board)
 - 3 LAN_CNV PCB
 - 4 GNSS_LNA 1
 - 5 GNSS_LNA 2
 - 6 GNSS_LNA 3 (Available only for SC-130 systems)
 - 3 JUNCTION BOX
 - 1 MAIN PCB
 - 2 LAN_CNV PCB
 - 3 TB_PWR PCB
- 2 DIAGNOSTICS
 - 1 MEMORY TEST
 - 2 KEY TEST
 - 3 LCD TEST
 - 4 AUTOMATIC TEST
 - 5 MANUAL TEST (For technical personnel only. Do not use.)
 - 6 SOUND TEST
- 3 IMPORT/EXPORT
 - IMPORT USER SETTING
 - EXPORT USER SETTING

5 I/O

- 1 DATA 1
 - 1 DATA OUTPUT (*IEC/NMEA*, RTCM*2) *2: Selectable for DATA5 only
 - 2 OUTPUT FORMAT (*IEC61162-1 ED.5*, IEC61162-1 ED.3, NMEA0183 V2.0, NMEA0183 V1.5)
 - 3 TALKER*3 (GP, GL, GA, GN, *HE*, HN, HC) *3: Non-IMO only, fixed for IMO
 - 4 BAUD RATE (4800bps, 9600bps, 19200bps, **38400bps**) *3 *4
 - 5 SENTENCES *4: Default for IEC61162-2 is 38400bps
- 2 DATA 2
 - 1 DATA OUTPUT (*IEC/NMEA*, RTCM*2)
 - 2 OUTPUT FORMAT (*IEC61162-1 ED.5*, IEC61162-1 ED.3, NMEA0183 V2.0, NMEA0183 V1.5)
 - 3 TALKER (GP, GL, GA, GN, *HE*, HN, HC)
 - 4 BAUD RATE (**4800bps**, 9600bps, 19200bps, 38400bps)
 - 5 SENTENCES
- 3 DATA 3 (Same as DATA 2)
- 4 DATA 4 (Same as DATA 2)
- 5 DATA 5 (Same as DATA 2)
- 6 NETWORK
 - 1 TALKER*6 (GP, GL, GA, GN, *HE*, HN, HC) *6: Non-IMO only, fixed for IMO
 - 2 SENTENCES
 - 3 IP ADDRESS/PORT
- 7 DATA SOURCE
 - 1 HDG (*INTERNAL LAN*, DATA 1, DATA 2, DATA 3, DATA 4, DATA 5, USER PRIORITY)
 - 2 EXT. STW*6 (DATA 1, DATA 2, DATA 3, DATA 4, DATA 5, *USER PRIORITY*)
- 8 I/O LOGS
 - 1 DATA 1(Shows TX/RX log)
 - 2 DATA 2(Shows TX/RX log)
 - 3 DATA 3(Shows TX/RX log)
 - 4 DATA 4(Shows TX/RX log)
 - 5 DATA 5(Shows TX/RX log)
 - 6 ETHERNET
 - 7 CANbus *7: Fixed to OFF when unit is set to [RUSSIA] and [MERCHANT] at installation.
 - 8 LAN ERROR LOG
- 9 MISCELLANEOUS
 - 1 HDG OUTPUT RESTART (*AUTO*, MANUAL)
 - 2 STW*6 (*VECTOR*, SCALAR)
 - 3 REPEATER BACKUP HDG OUTPUT (ON, *OFF*) *7
 - 4 COG HOLD (LOW SPD) (*ON*, OFF)

Continued on page AP-3

Continued from page AP-2

6 SENSOR

- | 1 OFFSET (For technical personnel only. Do not use.)
 - | 1 HDG OFFSET (-180°000' to +180°000', default: **+0.000°**)
 - | 2 PITCH OFFSET (-10°000' to +10°000', default: **+0.000°**)
 - | 3 ROLL OFFSET (-10°000' to +10°000', default: **+0.000°**)
 - | 4 POSITION OFFSET
 - | 5 DIMENSIONS/CCRP
 - | 6 SOG OFFSET -12.5% to +12.5%, default: **+00.0%**
 - | 7 ATM OFFSET (-99.9hPa to +99.9hPa, default: **00.0hPa**)
 - | 8 TEMP OFFSET (-99.9°C to +99.9°C, default: **+00.0°C**)
- | 2 OTHER
 - | 1 ANTENNA RESTART (For technical personnel only. Do not use.)
 - | 2 GNSS RESTART
 - | 3 CLEAR MAGNETIC DEVICE(For technical personnel only. Do not use.)
 - | 4 DR TIME (1min, 2min, 3min, 4min, **5min**)
 - | 5 MAGNETIC VARIATION*6 (**AUTO**, MANUAL)
- | 3 SENSOR STATUS *6: Non-IMO only, fixed for IMO

7 SYSTEM

- | 1 NETWORK (For technical personnel only. Do not use.)
 - | 1 ETHERNET
 - | 2 EQUIPMENT ID (001 to 999, default: **1**)
 - | 3 MP PORT (**ENABLE**, DISABLE)
 - | 4 MP IP ADDRESS/PORT
 - | 5 SFI
- | 2 SIMULATION
 - | 1 MOVEMENT SETTING
 - | 2 ATTITUDE SETTING
 - | 3 SIMULATED OUTPUT (**FULL SIMULATION**, FIX, DIFFERENTIAL FIX, ESTIMATION (DR), MANUAL INPUT, NO FIX) (For technical personnel only. Do not use.)
 - | 4 SIMULATION START (START, **STOP**)
- | 3 SYSTEM SOUND
 - | 1 KEY BEEP (**ON**, OFF)
 - | 2 NOTIFICATION SOUND (OFF, **ON**, CONTINUOUS) (For technical personnel only. Do not use.)
- | 4 SYSTEM LOG
 - | RECORDING (ON, **OFF**)
 - | LOG LEVEL (For technical personnel only. Do not use.)
- | 5 LOG RECORDING
 - | 1 LOG TYPE (**OFF**, GNSS ONLY, SENSOR ONLY, OFFLINE DATA)
 - | 2 DESTINATION (**USB**, MP)
- | 6 RESET SETTINGS
 - | 1 CLEAR DISPLAY SETTINGS
 - | 2 CLEAR GNSS
 - | 3 FACTORY DEFAULT (For service personnel only. Do not use.)
 - | 4 CLEAR ETHERNET SETTING (For service personnel only. Do not use.)
- | 7 KEY CODE
 - | 1 LOGOUT *8: Shown only if a USB device is connected.
 - | 2 CHANGE
- | 8 USB FLASH DRIVE (**UNMOUNT**) *8

8 SERVICE — EDIT (**LOCK**, UNLOCK) (Key code protected. For technical personnel only.)

APPX. 2 ALERT LIST

The table below shows the alert no., alert name, text, priority, meaning and remedy for each alert. The alerts table is grouped by device mode. Alerts are not shared between device modes.

Note 1: "Inst." in the following tables denotes "Instance number" for the alert.

Note 2: "GNSS CORE(4) FAULT" appears only if SC-1303 is connected to the system.

Note 3: SC-70/130 alerts are output only as navigation cluster alerts.

Note 4: In accordance with IEC62923, signals from the Data1 port (IEC61162-2), Data 2 through 5 ports (IEC61162-1) and/or LAN port (61162-450) can be connected to a CAM device for alert management.

Note 5: The BAM function type for the SC-70 and SC-130 is "P".

ALERT I/F1 and LEGACY Alerts

No.	Inst.	Alert name	Text	Priority/Category	Meaning
210*	—	HDOP exceeded	HDOP EXCEEDED	Caution/B	The value of HDOP (Horizontal Dilution of Precision) is 4 or above.
212	—	Loss of position	LOSS OF POSITION	Warning/B	Position data connection is interrupted or physically disconnected.
301*	—	Dead-Reckoning	DEAD-RECKONING	Caution/B	The heading is calculated using ROT, not GPS position.
302	—	Output stopped (HDG)	OUTPUT STOPPED (HDG)	Warning/B	Heading data connection is interrupted or physically disconnected.
303	—	Output stopped (ROT)	OUTPUT STOPPED (ROT)	Warning/B	ROT data is connection is interrupted or physically disconnected.
311	—	Output stopped (SPD)	OUTPUT STOPPED (SPD)	Warning/B	Speed data is connection is interrupted or physically disconnected.
Remedy: If the same state continues for five minutes, contact your dealer.					

*: When the SC-70/130 [TYPE APPROVAL] is set as [RUSSIA] at installation, these alerts are assigned the priority and category of "Warning/B".

ALERT I/F2 Alerts

Note 1: All ALERT I/F2 Warning level alerts have responsibility transfer function. Caution level alerts are not transferred.

Note 2: All ALERT I/F2 Warning level alerts are escalated as Warning level alerts if they are not acknowledged or rectified within five minutes.

No.	Inst.	Alert name	Text	Priority/Category	Meaning
GPS mode alerts					
3056	1	HDOP EXCEEDED	HDOP EXCEEDED	Caution/B	The value of HDOP (Horizontal Dilution of Precision) is 4 or above.
Remedy: If the same state continues for five minutes, contact your dealer.					
3008	1	LOSS OF POSITION	GNSS CORE(1) FAULT	Warning/B	GNSS module may be faulty.
	5		TOO FEW TRACKING SATELLITES		Not enough satellites available to fix position.
	6		ANTENNA UNIT CONNECTION LOST		Data connection to the antenna has been interrupted or the physical connection is disconnected.
Remedy: If the same state continues for five minutes, contact your dealer.					
THD mode alerts					
3016	2	LOST GNSS SIGNAL	GNSS CORE(2) FAULT	Caution/B	GNSS module may be faulty.
	3		GNSS CORE(3) FAULT		GNSS module may be faulty.
	4		GNSS CORE(4) FAULT		GNSS module may be faulty. Note: Shown only for system configurations with SC-1303 included.
	5		TOO FEW COMMON SATELLITES		Not enough satellites available to fix position.
Remedy: If this alert occurs frequently, contact your dealer.					
Note: The "LOST GNSS SIGNAL" alerts (3016.x) are changed to "LOST HDG OUTPUT" alerts (3008,x) alerts if they are not rectified or fixed within the time period set at [DR TIME] (dead reckoning time) in the menu.					
3008	2	LOST HDG OUTPUT	GNSS CORE(2) FAULT	Warning/B	GNSS module may be faulty.
	3		GNSS CORE(3) FAULT		GNSS module may be faulty.
	4		GNSS CORE(4) FAULT		GNSS module may be faulty. Note: Shown only for system configurations with SC-1303 included.
	5		TOO FEW COMMON SATELLITES		Not enough satellites available to fix position.
	6		ANTENNA UNIT CONNECTION LOST		Data connection to the antenna has been interrupted or the physical connection is disconnected.

No.	Inst.	Alert name	Text	Priority/Category	Meaning
3008	7	LOST HDG OUTPUT	RATE GYRO BROKEN DOWN	Warning/B	Rate gyro may be faulty.
	8		ACCELEROMETER BROKEN DOWN		Accelerometer may be faulty.
	10		NO EXTERNAL HDG		External heading data is not received for five seconds.
	18		INTERNAL HDG ERROR		Abnormal internal heading data is detected.
	19		SETTLING FAILURE		Unable to obtain a stable heading for more than 10 minutes after start-up. Note: Appears when the unit is set to [RUSSIA] at installation.
Remedy: If the same state continues for five minutes, contact your dealer.					
ROTI mode alerts					
440303	2	ROT STOPPED	GNSS CORE(2) FAULT	Warning/B	GNSS module may be faulty.
	3		GNSS CORE(3) FAULT		GNSS module may be faulty.
	4		GNSS CORE(4) FAULT		GNSS module may be faulty. Note: Shown only for system configurations with SC-1303 included.
	5		TOO FEW COMMON SATELLITES		Not enough satellites available to fix position.
	6		ANTENNA UNIT CONNECTION LOST		Data connection to the antenna has been interrupted or the physical connection is disconnected.
	7		RATE GYRO BROKEN DOWN		Rate gyro may be faulty.
	8		ACCELEROMETER BROKEN DOWN		Accelerometer may be faulty
	18		INTERNAL ROT ERROR		Abnormal internal ROT data is detected.
	19		SETTLING FAILURE		Unable to obtain a stable heading for more than 10 minutes after start-up. Note: Appears when the unit is set to [RUSSIA] at installation.
Remedy: If the same state continues for five minutes, contact your dealer.					
SPD mode alerts					
440311	2	SPD STOPPED	GNSS CORE(2) FAULT	Warning/B	GNSS module may be faulty.
	3		GNSS CORE(3) FAULT		GNSS module may be faulty.

No.	Inst.	Alert name	Text	Priority/ Category	Meaning
440311	4	SPD STOPPED	GNSS CORE(4) FAULT	Warning/ B	GNSS module may be faulty. Note: Shown only for system configurations with SC-1303 included.
	5		TOO FEW COMMON SATELLITES		Not enough satellites available to fix position.
	6		ANTENNA UNIT CONNECTION LOST		Data connection to the antenna has been interrupted or the physical connection is disconnected.
	7		RATE GYRO BROKEN DOWN		Rate gyro may be faulty.
	8		ACCELEROMETER BROKEN DOWN		Accelerometer may be faulty
Remedy: If the same state continues for five minutes, contact your dealer.					

APPENDIX 3 ABBREVIATIONS AND UNITS





Term	Meaning	Term	Meaning
Numerical:			
2D	Two Dimensional Positioning	3D	Three Dimensional Positioning
A:			
ACK	Acknowledge	APR	April
ADR	Address	ARPA	Automatic Radar Plotting Aid
AIS	Automatic Identification System	ATM	Atmospheric Pressure
ALARM	Alarm	AUG	August
ANT	Antenna	Auto	Automatic
B:			
BAM(S)	Bridge Alert Management (System)	BRG	Bearing
BKGD	Background	BRILL	Brilliance
BL	BaseLine	bps	Bits Per Second
C:			
CAN	Controlled Area Network	CNV	Converter
CALC	GPS baseline calculation	COM.	Common
CCRP	Consistent Common Reference Point	COG	Course Over Ground
CLR	Clear	CPU	Central Processing Unit
D:			
DEC	December	DR	Dead Reckoning
deg	Degree(s)	DST	Destination
deg/min	Degree(s) per minute	D2D	Differential + 2D
DISP	Display	D3D	Differential + 3D
DGPS	Differenetal GPS		
E:			
E	East	ENT	Enter
ECDIS	Electronic Chart Display and Information System	EXT.	External
EGNOS	European Geostationary Navigational Overlay System		
F:			
FEB	February	FREQ	Frequency
FIX	Fix		
G:			
GLONASS	Global Opening Navigation Satellite System	GNSS	Global Navigation Satellite System
GND	Ground	GPS	Global Positioning System
GP-3D	GPS used for position fix.	GP-D3D	GPS differential used for position fix.
H:			
HDG	Heading	hPa	Hectopascal
HDOP	Horizontal Dilution of Position		
I:			
ID	Identification	INFO	Information
I/F	Interface	INIT	Initial
IEC	International Electrotechnical Commission	I/O	Input/Output
IMO	International Maritime Organization	IP	Internet Protocol
IMU	Inertial Measurement Unit		
J:			
JAN	January	JUN	June
JUL	July		
L:			
L	Local (time)	L/L	Latitude/Longitude
LAN	Local Area Network	LOC	Location
LEN	Load Equivalency Number	LOG	Log
LCD	Liquid Crystal Display		

APPENDIX 3 ABBREVIATIONS AND UNITS

M:			
MAR	March	MP	Management Profile
MAY	May	MSAS	Multi-Functional Satellite Augmentation System
MENU	Menu		
N:			
N	North	NMEA	National Marine Electronics Association
N/A	Not Available	NOV	November
NG	Not Good	NO.	Number
O:			
OCT	October	ON	On
OFFSET	Offset	OS	Own Ship
P:			
PC	Printed Circuit	PGN	Parameter Group Number
PCB	Printed Circuit Board	PORT	Port
PDOP	Positional Dilution Of Precision	PRN	Pseudo-Random Noise
POSN	Position		
Q:			
QZSS	Quasi-Zenith Satellite System		
R:			
RAM	Random Access Memory	ROM	Read Only Memory
RAIM	Receiver Autonomous Integrity Monitoring	ROT	Rate Of Turn
RECT	Rectified	ROTI	Rate Of Turn Indicator
RMS	Root Mean Square	RTCM	Radio Technical Commission for Marine Service
RNG	Range	RX	Receive
S:			
S	South	SOG	Speed Over Ground
SAT	Satellite	SPD	Speed
SBAS	Satellite Base Argument System	SRC	Source
SC	Satellite Compass	SS	Signal Sensitivity
SEP	September	STBD	Starboard
SET	Set (i.e. set and drift, or setting a value)	STW	Speed Through the Water
SFI	System Function ID	SV	Space Vehicle
SIM	Simulation	SYS	System
SN	Signal to Noise	S2D	SBAS + 2D
SNR	Signal to Noise Ratio	S3D	SBAS + 3D
T:			
T	TRUE	THD	Transmitting Heading Device
TEST	Test	TIME	Time
TEMP	Temperature	TX	Transmit
U:			
U/UTC	Universal Time, Coordinated	USB	Universal Serial Bus
W:			
W	West	WGS	World Geodetic System
WAAS	Wide Area Augmentation System	WGS84	World Geodetic System 84
Units of measurement			
Unit	Meaning	Unit	Meaning
°	Degree(s)	m/s	Meter(s) per second
°/min	Degree(s) per minute	ms	Milisecond(s)
dB	Decibel(s)	NM	Nautical Mile(s)
kHz	Kilohertz	Ω	Ohm(s)
KM	Kilometer(s)	s	Second(s)
m	Meter(s)	SM	Statue Mile(s)
min or '	Minute(s)		









APPX. 4 ICONS AND SYMBOLS

Standard icons and their meanings

Icon	Meaning	Icon	Meaning
 See note below.	Excessive vibrations detected at the antenna installation location. Check the antenna installation location and change if necessary.	 Shown in light blue for IMO types, dark-blue for non-IMO types.	Blue indication rotates in a clock-wise direction, indicating that the equipment is functioning correctly. If this indication is not moving, the system may be frozen. Restart the system. If the problem recurs, contact your dealer.
 See note below.	Indicates that five or more satellites are under use for calculating velocity and own ship's movement.		Simulation icon. The system is currently operating in simulation mode.

Note: Icon background color changes according to the SC-702 background color.

Alert icons and their meanings

Icons	Meaning	Icons	Meaning
	Active, unacknowledged warning		Active, acknowledged warning
	Silenced warning		Caution
	Rectified, unacknowledged warning		Background warning
	Active, responsibility transferred warning (See section 2.11.7)		Background caution

APPX. 5 GEODETIC CHART CODES

001: WGS84		091: NORTH AMERICAN 1927	: Bahamas (excl. San Salvador Is.)
002: WGS72		092: NORTH AMERICAN 1927	: Bahamas, San Salvador Is.
003: TOKYO	: Mean Value (Japan, Korea & Okinawa)	093: NORTH AMERICAN 1927 (Cont'd)	: Canada (incl. Newfoundland Is.)
004: NORTH AMERICAN 1927	: Mean Value (CONUS)	094: NORTH AMERICAN 1927 (Cont'd)	: Alberta & British Columbia
005: EUROPEAN 1950	: Mean Value	095: NORTH AMERICAN 1927 (Cont'd)	: East Canada
006: AUSTRALIAN GEODETIC 1984	: Australia & Tasmania	096: NORTH AMERICAN 1927 (Cont'd)	: Manitoba & Ontario
007: ADINDAN	: Mean Value (Ethiopia & Sudan)	097: NORTH AMERICAN 1927 (Cont'd)	: Northwest Territories & Saskatchewan
008: ADINDAN	: Ethiopia	098: NORTH AMERICAN 1927 (Cont'd)	: Yukon
009: ADINDAN	: Mali	099: NORTH AMERICAN 1927 (Cont'd)	: Canal Zone
010: ADINDAN	: Senegal	100: NORTH AMERICAN 1927 (Cont'd)	: Caribbean
011: ADINDAN	: Sudan	101: NORTH AMERICAN 1927 (Cont'd)	: Central America
012: AFG	: Somalia	102: NORTH AMERICAN 1927 (Cont'd)	: Cuba
013: AIN EL ABD 1970	: Bahrain Is.	103: NORTH AMERICAN 1927 (Cont'd)	: Greenland
014: ANNA 1 ASTRO 1965	: Cocos Is.	104: NORTH AMERICAN 1927 (Cont'd)	: Mexico
015: ARC 1950	: Mean Value	105: NORTH AMERICAN 1983	: Alaska
016: ARC 1950	: Botswana	106: NORTH AMERICAN 1983	: Canada
017: ARC 1950	: Lesotho	107: NORTH AMERICAN 1983	: CONUS
018: ARC 1950	: Malawi	108: NORTH AMERICAN 1983	: Mexico, Central America
019: ARC 1950	: Swaziland	109: OBSERVATORIO 1966	: Corvo & Flores Is. (Azores)
020: ARC 1950	: Zaire	110: OLD EGYPTIAN 1930	: Egypt
021: ARC 1950	: Zambia	111: OLD HAWAIIAN	: Mean Value
022: ARC 1950	: Zimbabwe	112: OLD HAWAIIAN	: Hawaii
023: ARC 1960	: Mean Value (Kenya & Tanzania)	113: OLD HAWAIIAN	: Kauai
024: ARC 1960	: Kenya	114: OLD HAWAIIAN	: Maui
025: ARC 1960	: Tanzania	115: OLD HAWAIIAN	: Oahu
026: ASCENSION IS. 1958	: Ascension Is.	116: OMAN	: Oman
027: ASTRO BEACON "E"	: Iwo Jima Is.	117: ORDNANCE SURVEY OF GREAT BRITAIN 1936	: Mean Value
028: ASTRO B4 SOR. ATOLL	: Tern Is.	118: ORDNANCE SURVEY OF GREAT BRITAIN 1936	: England
029: ASTRO POS 71/4	: St. Helena Is.	119: ORDNANCE SURVEY OF GREAT BRITAIN 1936	: England, Isle of Man & Wales
030: ASTRONOMIC STATION 1952	: Marcus Is.	120: ORDNANCE SURVEY OF GREAT BRITAIN 1936	: Scotland & Shetland Is.
031: AUSTRALIAN GEODETIC 1966	: Australia & Tasmania	121: ORDNANCE SURVEY OF GREAT BRITAIN 1936	: Wales
032: BELLEVUE (IGN)	: Efate & Erromango Is.	122: PICO DE LAS NIVIES	: Canary Is.
033: BERMUDA 1957	: Bermuda Is.	123: PITCAIRN ASTRO 1967	: Pitcairn Is.
034: BOGOTA OBSERVATORY	: Columbia	124: PROVISIONAL SOUTH CHILEAN 1963	: South Chile (near 53°S)
035: CAMPO INCHAUSPE	: Argentina	125: PROVISIONAL SOUTH AMERICAN 1956	: Mean Value
036: CANTON IS. 1966	: Phoenix Is.	126: PROVISIONAL SOUTH AMERICAN 1956	: Bolivia
037: CAPE	: South Africa	127: PROVISIONAL SOUTH AMERICAN 1956	: Chile-Northern Chile (near 19°S)
038: CAPE CANAVERAL	: Mean Value (Florida & Bahama Is.)	128: PROVISIONAL SOUTH AMERICAN 1956	: Chile-Southern Chile (near 43°S)
039: CARTHAGE	: Tunisia	129: PROVISIONAL SOUTH AMERICAN 1956	: Columbia
040: CHATHAM 1971	: Chatham Is. (New Zealand)	130: PROVISIONAL SOUTH AMERICAN 1956	: Ecuador
041: CHUA ASTRO	: Paraguay	131: PROVISIONAL SOUTH AMERICAN 1956	: Guyana
042: CORREGO ALEGRE	: Brazil	132: PROVISIONAL SOUTH AMERICAN 1956	: Peru
043: DJAKARTA (BATAVIA)	: Sumatra Is. (Indonesia)	133: PROVISIONAL SOUTH AMERICAN 1956	: Venezuela
044: DOS 1968	: Gizo Is. (New Georgia Is.)	134: PUERTO RICO	: Puerto Rico & Virgin Is.
045: EASTER IS. 1967	: Easter Is.	135: QATAR NATIONAL	: Qatar
046: EUROPEAN 1950 (Cont'd)	: Western Europe	136: QORNOQ	: South Greenland
047: EUROPEAN 1950 (Cont'd)	: Cyprus	137: ROME 1940	: Sardinia Is.
048: EUROPEAN 1950 (Cont'd)	: Egypt	138: SANTA BRAZ	: Sao Miguel, Santa Maria Is. (Azores)
049: EUROPEAN 1950 (Cont'd)	: England, Scotland, Channel & Shetland Is.	139: SANTO (DOS)	: Espirito Santo Is.
050: EUROPEAN 1950 (Cont'd)	: England, Ireland, Scotland & Shetland Is.	140: SAPPER HILL 1943	: East Falkland Is.
051: EUROPEAN 1950 (Cont'd)	: Greece	141: SOUTH AMERICAN 1969	: Mean Value
052: EUROPEAN 1950 (Cont'd)	: Iran	142: SOUTH AMERICAN 1969	: Argentina
053: EUROPEAN 1950 (Cont'd)	: Italy, Sardinia	143: SOUTH AMERICAN 1969	: Bolivia
054: EUROPEAN 1950 (Cont'd)	: Italy, Sicily	144: SOUTH AMERICAN 1969	: Brazil
055: EUROPEAN 1950 (Cont'd)	: Norway & Finland	145: SOUTH AMERICAN 1969	: Chile
056: EUROPEAN 1950 (Cont'd)	: Portugal & Spain	146: SOUTH AMERICAN 1969	: Columbia
057: EUROPEAN 1979	: Mean Value	147: SOUTH AMERICAN 1969	: Ecuador
058: GANDAJIKA BASE	: Republic of Maldives	148: SOUTH AMERICAN 1969	: Guyana
059: GEODETIC DATUM 1949	: New Zealand	149: SOUTH AMERICAN 1969	: Paraguay
060: GUAM 1963	: Guam Is.	150: SOUTH AMERICAN 1969	: Peru
061: GUX 1 ASTRO	: Guadalcanal Is.	151: SOUTH AMERICAN 1969	: Trinidad & Tobago
062: HJORSSEY 1955	: Iceland	152: SOUTH AMERICAN 1969	: Venezuela
063: HONG KONG 1963	: Hong Kong	153: SOUTH ASIA	: Singapore
064: INDIAN	: Thailand & Vietnam	154: SOUTHEAST BASE	: Porto Santo & Madeira Is.
065: INDIAN	: Bangladesh, India & Nepal	155: SOUTHWEST BASE	: Faial, Graciosa, Pico, Sao Jorge & Terceira Is.
066: IRELAND 1965	: Ireland	156: TIMBALAI 1948	: Brunei & East Malaysia (Sarawak & Sabah)
067: ISTS 073 ASTRO 1969	: Diego Garcia	157: TOKYO	: Japan
068: JOHNSTON IS. 1961	: Johnston Is.	158: TOKYO	: Korea
069: KANDAWALA	: Sri Lanka	159: TOKYO	: Okinawa
070: KERGUELEN IS.	: Kerguelen Is.	160: TRISTAN ASTRO 1968	: Tristan da Cunha
071: KERTAU 1948	: West Malaysia & Singapore	161: VITI LEVU 1916	: Viti Levu Is. (Fiji Is.)
072: LA REUNION	: Mascarene Is.	162: WAKE-ENIWETOK 1960	: Marshall Is.
073: L. C. 5 ASTRO	: Cayman Brac Is.	163: ZANDERIJ	: Surinam
074: LIBERIA 1964	: Liberia	164: BUKIT RIMPAH	: Bangka & Belitung Is. (Indonesia)
075: LUZON	: Philippines (excl. Mindanao Is.)	165: CAMP AREA ASTRO	: Camp Marmurdo Area, Antarctica
076: LUZON	: Mindanao Is.	166: G. SEGARA	: Kalimantan Is. (Indonesia)
077: MAHE 1971	: Mahe Is.	167: HERAT NORTH	: Afghanistan
078: MARCO ASTRO	: Salvage Islands	168: HU-TZU-SHAN	: Taiwan
079: MASSAWA	: Eritrea (Ethiopia)	169: TANANARIVE OBSERVATORY 1925	: Madagascar
080: MERCHICH	: Morocco	170: YACARE	: Uruguay
081: MIDWAY ASTRO 1961	: Midway Is.	171: RT-90	: Sweden
082: MINNA	: Nigeria	172: CK42 (PULKOVO 1942)	: Russia
083: NAHRWAN	: Masirah Is. (Oman)	173: FINNISH KKJ	: Finland
084: NAHRWAN	: United Arab Emirates	174: PZ90	: Russia
085: NAHRWAN	: Saudi Arabia	175: CK95	: Russia
086: NAMIBIA	: Namibia		
087: MAPARIMA, BWI	: Trinidad & Tobago		
088: NORTH AMERICAN 1927	: Western United States		
089: NORTH AMERICAN 1927	: Eastern United States		
090: NORTH AMERICAN 1927	: Alaska		

APPX. 6 WHAT IS SBAS?

A satellite based augmentation system, or SBAS (Satellite Based Augmentation System), is an augmentation system that uses additional messages from satellite broadcasts to support regional and wide area augmentation. SBAS provides GPS signal corrections to SBAS users, for even better position accuracy, through the GPS error corrections that are widely broadcast from the geostationary satellite.

SBAS is used in America, Europe, Japan and India.

- America: WAAS (Wide Area Augmentation System)
- Europe: EGNOS (Euro Geostationary Navigation Overlay Service)
- Japan: MSAS (Multi-Functional Satellite Augmentation System)
- India: GAGAN (GPS And GEO Augmented Navigation)

These four systems have interoperability. The illustration below shows the coverage area for each provider. This manual uses "SBAS" for these four providers generically.

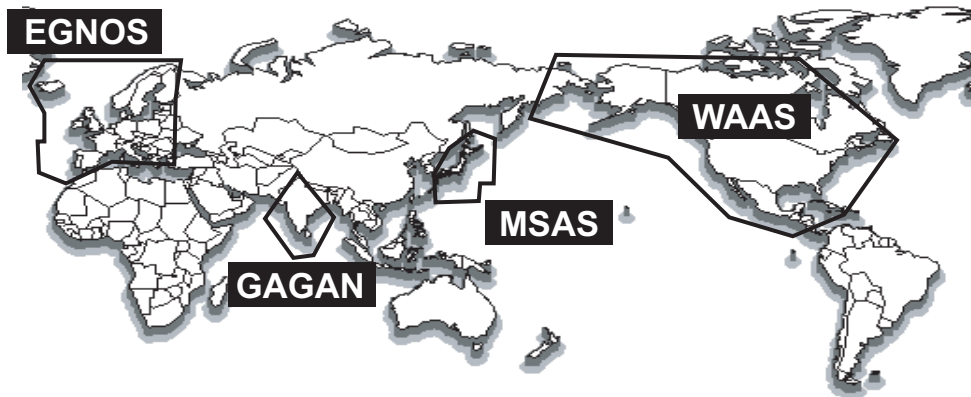

Provider	Satellite type	Longitude	Satellite No.
WAAS	Intelsat Galaxy XV	133°W	135
	TeleSat Anik F1R	107.3°W	138
	Inmarsat-4-F3	98°W	133
EGNOS	Inmarsat-3-F2/AOR-E	15.5°W	120
	Inmarsat-4-F2	25°E	126
	SES-5	5°E	136
MSAS	MTSAT-1R	140°E	129
	MTSAT-2	145°E	137
GAGAN	GSAT-8	55°E	127
	GSAT-10	83°E	128

As of March 6th, 2014

APPX. 7 DIGITAL INTERFACE (IEC 61162-1 EDITION 5)

Serial data sentences

Input: ACK, ACN (ACM), HBT, HDT*¹, MSK, MSS, THS, VBW*², VDR*²

Output: ALC, ALF, ALR, ARC, DTM, GBS, GGA, GLL, GNS, GRS, GSA, GST, GSV, HBT, HDG*², HDM*², HDT*¹, HRM*², MSK, POS, RMC, ROT, THS, VBW*², VDR*², VHW*², VLW*², VTG, XDR*², ZDA

Ethernet sentences

Input: ACK, ACN (ACM), HBT, SRP

Output: ALC, ALF, ALR, ARC, DTM, GBS, GLL, GNS, GRS, GSA, GST, GSV, HBT, HDG, HDM, HDT*¹, HRM*², POS, RMC, ROT, SRP, THS, VBW*², VDR*², VHW*², VLW*², VTG, XDR*², ZDA

*¹: Not used for new SOLAS vessels.

*²: For Non-IMO types only.

Transmission Interval

Sentence	Available intervals
DTM*/GBS/GGA/GLL/GNS/GRS/GSA/GST/GSV/RMC/VBW/VDR/VHW/VLW/VTG/XDR/ZDA	0s, 1s, 2s
HDT/ROT/THS/HDG/HDM/HRM	20ms, 25ms, 100ms, 200ms, 1s, 2s
ALC/ALF/ALR/ARC/MSK	Fixed (Not changeable).

*: Fixed for IMO type vessels.

Load requirements as listener

Isolation: Photo coupler

Input impedance: 470 ohms

Max. voltage: ±15 V

Threshold: 3 mA (in case of connection with FURUNO device talker)

Data transmission

Data is transmitted in serial asynchronous form in accordance with the standard referenced in IEC 61162-1 and IEC 61162-2. The first bit is a start bit and is followed by data bits.

The following parameters are used: Baud rate: 4800 for IEC61162-1, 38400 for IEC-61162-2
Data bits: 8 (D7 = 0), parity none
Stop bits: 1
datagram type and IGMP protocol.
IEC61162-1: Edition 5.0 2016, Edition 4.0 2010-11, Third edition 2007-04
IEC61162-2: First Edition 1998-09
IEC61162-450: Edition 2.0 2018-05, Datagram type: UdPb
CIGMP protocol: IGMPv2

Schematic diagrams

Data ports 2 through 5

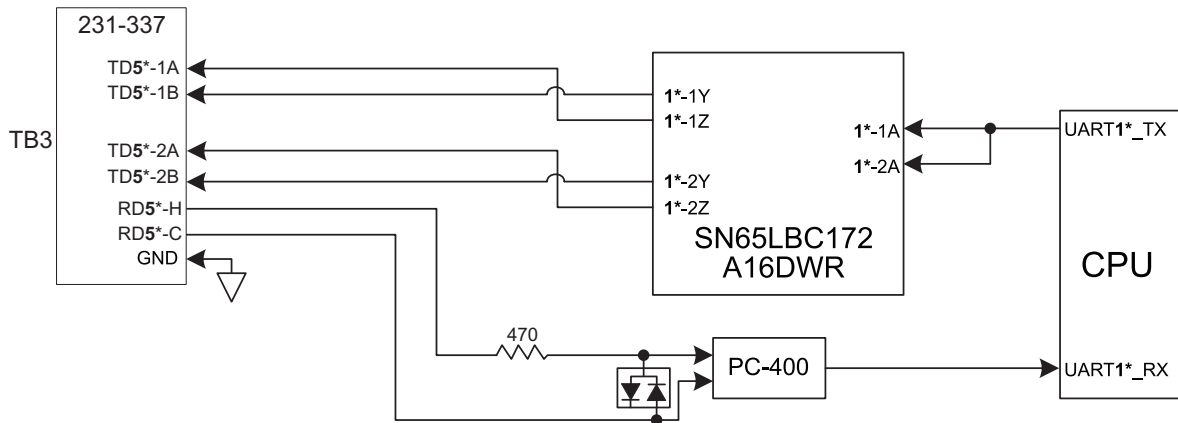

*: Numerals in bold change as follows, with their respective terminal blocks.
 TB4: **4**; TB5: **3**; TB6: **2**

Data port 1

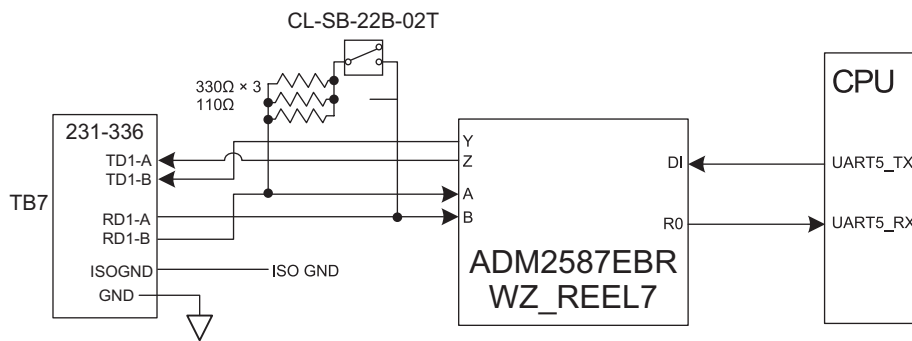

Sentence description (Input)

- ACK: Acknowledge Alarm

\$**ACK,xxx,*hh<CR><LF>
 1

1. Local alarm number (identifier) (000 to 999)

- ACN (ACM): Alert Command

\$**ACN,hhmmss.ss,aaa,x.x,x.x,c,a*hh<CR><LF>
 1 2 3 4 5 6

1. Time (UTC,unused)
2. Manufacturer mnemonic code (3 digits)
3. Alert Identifier (000 - 999999)
4. Alert Instance (1 - 999999,unused)
5. Alert command (A,Q,O,S)
 A=acknowledge
 Q=request/repeat information
 O=responsibility transfer
 S=silence
6. Sentence status flag(C) (fixed)

- **HBT: Heartbeat Supervision Sentence**

```
$**HBT,x.x,A,x*hh<CR><LF>
  1 2 3
```

1. Configured repeat interval (1 to 999(s))
2. Equipment status (A=Normal V=System fail)
3. Sequential sentence identifier (0 to 9)

- **HDT: Heading, true**

```
$**HDT,xxx.x,T*hh<CR><LF>
  1 2
```

1. Heading, degrees (0.0 to 360.0)
2. True (T)

- **MSK: Receiver Interface Command**

```
$**MSK,x.x,a,x.x,a,x.x,x,a *hh<CR><LF>
  1 2 3 4 5 6 7
```

1. Beacon frequency, kHz (283.45 to 325.04)
2. Auto/Manual frequency (See note 2) (A=Auto, M=Manual)
3. Beacon bit rate, bits/s (25, 50, 100, 150, 200)
4. Auto/Manual beacon bit rate (See note 2) (A=Auto, M=Manual)
5. Interval for sending \$**MSS (status) in seconds (See note 1) (1 to 99, null))
6. Channel number (See note 3) (Fixed at 1)
7. Sentence status flag (See note 4) (R, C) (R= Sentence status is a report of current settings (use for a reply to a query, C= Sentence is a configuration command to change settings. A sentence without "C" is not a command.)

Notes:

- 1) When status data is not to be transmitted this field is "null".
- 2) If Auto is specified the previous field value is ignored.
- 3) Set equal to "1" or null for single channel receiver.
- 4) This field is used to indicate a sentence that is a status report of current settings or a configuration command changing settings. This field should not be null.

- **MSS: MSK Receiver Signal Status**

```
$**MSS,x.x,x.x,x.x,x.x,x *hh<CR><LF>
  1 2 3 4 5
```

1. Signal strength (SS), dB/(1 μ V/m) (0.0 to 999.94)
2. Signal-to-noise ratio (SN), dB (0.0 to 999.94)
3. Beacon frequency, kHz (283.5 to 325.04)
4. Beacon bit rate, bits/s (25, 50, 100, 200)
5. Channel number (1,null)(Set to "1" or "null" for single channel receivers.)

- **SRP - System Function ID Resolution Protocol**

```
$--SRP,x,hhhhhhhhhhh,c--c*hh<CR><LF>
  1 2 3
```

1. Instance number for interface redundancy (i.e. number of physical port for identical SFI), null if interface redundancy not in use. The instance numbers shall be ordinal with no skipping (1, 2, 3,...).
2. Reported MAC address used by SFI, 48bit hexadecimal number, for example 32613C4EB605
3. Reported IP address used by SFI as text string, for example 239.192.0.1

- THS: True Heading And Status

\$**THS,x.x,a*hh<CR><LF>
1 2

1. Heading, degrees True (0.0 to 360.0)
2. Mode indicator (A=Autonomous, S=Simulator)

- VBW: Dual Ground/water Speed

\$**VBW,x.x,x.x,a,x.x,x.x,a,x.x,a,x.x,a*hh<CR><LF>
1 2 3 4 5 6 7 8 9 10

1. Longitudinal water speed, knots (-999.994 to 999.994, null)
2. Transverse water speed, knots (-999.994 to 999.994, null)
3. Status: water speed (A=Data valid)
4. Longitudinal ground speed, knots (unused)
5. Transverse ground speed, knots (unused)
6. Status: ground speed, (A=Data valid, V=Data invalid)
7. Stern transverse water speed, knots (-999.994 to 999.994, null)
8. Status: stern water speed (A=Data valid)
9. Stern transverse ground speed, knots (unused)
10. Status: stern ground speed, (A=Data valid, V=Data invalid)

- VDR: Set and Drift

\$**VDR,x.x,T,x.x,M,x.x,N*hh <CR><LF>
1 2 3 4 5 6

1. Direction, degrees True (0.0 to 360.0,null)
2. T=True (fixed)
3. Direction, degrees Magnetic (0.0 to 360.0,null)
4. M=Magnetic (fixed)
5. Current speed (0 to 99.99)
6. N=Knots (fixed)

- Proprietary sentences: GPatt, GPhve, llals, pireq.

Sentence description (Output)

- ALC: Cyclic Alert List

\$**ALC,xx,xx,xx,x.x,aaa,x.x,x.x,x.x,"""*hh<CR><LF>
1 2 3 4 5 6 7 8 9

1. Total number of sentences this message (01 to 99)
2. Sentence number (01 to 99)
3. Sequential message identifier (00 to 99)
4. Number of alert entries (0 to 2)
5. Manufacturer mnemonic code (FEC, null)
6. Alert identifier (000 to 999999)
7. Alert instance (1 to 999999)
8. Revision counter (1 to 99)
9. Additional alert entries (same as 5 to 8)

- ALF: Alert Sentence

```
$**ALF,x,x,x,hhmmss.ss,a,a,a,aaa,x.x,x.x,x,x,c--c*hh<CR><LF>
      1 2 3      4      5 6 7 8 9 10 11 12 13
```

1. Total number of ALF sentences this message (1, 2)
2. Sentence number (1, 2)
3. Sequential message identifier (0 to 9)
4. Time of last change (hh=00 to 23, mm=00 to 59, ss.ss=00.00 to 59.99), null
5. Alert category (B=Alert category B,), null when #2 is 2.
6. Alert priority (W=Warning, C=Caution), null when #2 is 2.
7. Alert state (V=Not ACKed, S=Silence, A=ACKed, O/U=Resolved, Not ACKed, N=Normal state), null when #2 is 2.
8. Manufacturer mnemonic code (FEC, null)
9. Alert identifier (000 to 999999)
10. Alert instance (1 to 999999)
11. Revision counter (1 to 99)
12. Escalation counter (0 to 9)
13. Alert text (when #2 =1: max. 16 characters; when #2=2: max. characters according to regulation)

- ALR: Set Alarm State

```
$**ALR,Hhmmss.ss,xxx,A,A,c—c*hh<CR><LF>
      1      2 3 4 5
```

1. Time of alarm condition change, UTC (000000.00 to 235959.99), null
2. Unique alarm number (identifier) at alarm source (000 to 999),null
3. Alarm condition (A=threshold exceeded, V=threshold not exceeded)
4. Alarm acknowledge state (A=acknowledged, V=not acknowledged)
5. Alarm description text (alphanumeric), null

- ARC: Alert Command Refused

```
$**ARC,hhmmss.ss,aaa,x.x,x.x,c*hh<CR><LF>
      1      2 3 4 5
```

1. Release time of the Alert Command Refused (UTC)
2. Used for proprietary alerts, defined by the manufacturer (FEC,null)
3. The alert identifier (000 to 999999)
4. The alert instance (1 to 999999)
5. Refused Alert Command(A, Q, O, S)
A=acknowledge
Q=request/repeat information
O=responsibility transfer
S=silence

- DTM: Datum Reference

```
$**DTM,ccc,a,x.x,a,x.x,a,x.x,ccc*hh<CR><LF>
      1 2 3 4 5 6 7 8
```

1. Local datum (W84:WGS84; W72:WGS72; P90:PZ90; User defined:999, IHO datum code)
2. Local datum subdivision code (null or one character)
3. Lat offset, minutes (0 to 59.9999)
4. N/S
5. Lon offset, min (0 to 59.9999)
6. E/W
7. Altitude offset, meters (null)
8. Reference datum (W84:WGS84; W72:WGS72; P90:PZ90)

- **GBS: GNSS Satellite Fault Detection**

\$**GBS, hhmmss.ss, x.x, x.x, x.x, xx, x.x, x.x, x.x, h, h *hh<CR><LF>
 1 2 3 4 5 6 7 8 9 10

1. UTC time of GGA or GNS fix associated with this sentence (000000.00 to 235959.99)
2. Expected error in latitude (0.00 to 999.99),null
3. Expected error in longitude (0.00 to 999.99),null
4. Expected error in altitude (0.00 to 999.99),null
5. ID number of most likely failed satellite (1 to 255),null
6. Probability of missed detection for most likely failed satellite (0.00 to 100.00),null
7. Estimate of bias in meters on most likely failed satellite (-999.99 to 999.99),null
8. Standard deviation of bias estimate (0.00 to 999.99), null
9. GNSS system ID (1 to F)
10. GNSS signal ID (0 to F)

- **GGA - Global Positioning System Fix Data**

\$**GGA,hhmmss.ss,llll.lll,a,yyyyy.yyy,a,x,xx,x.x,x.x,M,x.x,M,x.x,xxxx*hh<CR><LF>
 1 2 3 4 5 6 7 8 9 10 11 12 13 14

1. UTC of position (000000.00 to 235959.99)
2. Latitude (0000.0000 to 9000.00000)
3. N/S
4. Longitude (0000.0000 to 18000.00000)
5. E/W
6. GPS quality indicator (0 to 8)
7. Number of satellite in use (00 to 99)
8. Horizontal dilution of precision (0.0 to 99.9)
9. Antenna altitude above/below mean sea level (-9999 to 9999)
10. Unit, (Fixed at m)
11. Geoidal separation (-9999 to 9999)
12. Unit, (Fixed at m)
13. Age of differential GPS data (0 to 299) ,null
14. Differential reference station ID (0000 to 1023),null

- **GLL: Geographic Position - Latitude/Longitude**

\$**GLL,llll.lll,a,yyyyy.yyy,a,hhmmss.ss,a,x*hh<CR><LF>
 1 2 3 4 5 6 7

1. Latitude (0000.0000 to 9000.0000)
2. N/S
3. Longitude (0000.0000 to 18000.0000)
4. E/W
5. UTC of position (000000.00 to 235959.99)
6. Status (A=data valid V=data invalid)
7. Mode indicator (A=Autonomous, D=Differential, E=Estimated (dead reckoning), M=Manual input, S=Simulator, N=Data not valid)

- **GNS: GNSS Fix Data**

\$**GNS,hhmmss.ss,llll.lll,a,lllll.lll,a,c--c,xx,x.x,x.x,x.x,x.x,x.x,a*hh<CR><LF>
 1 2 3 4 5 6 7 8 9 10 11 12 13

1. UTC of position (000000.00 to 235959.99)
2. Latitude (0000.0000 to 9000.0000)
3. N/S
4. Longitude (0000.0000 to 18000.0000)
5. E/W
6. Mode indicator
 N=No fix A=Autonomous D=Differential P=Precise R=Real Time Kinematic
 F=Float RTK E=Estimated Mode M=Manual Input Mode S=Simulator Mode
7. Total number of satellites in use (00 to 99)
8. HDOP (0.0 to 50.0)
9. Antenna altitude, meters (-9999 to 9999)
10. Geoidal separation (-9999 to 9999)
11. Age of differential data (0 to 99)
12. Differential reference station ID (0000 to 1023)
13. Navigational status indicator
 S=Safe C=Caution U=Unsafe V=Navigational status not valid

• GRS: GNSS Range Residual

\$**GRS,hhmmss.ss,x,xx,xx,xx,xx,xx,xx,xx,xx,xx,xx,xx,xx,h,h*hh<CR><LF>

1. UTC time of GGA/GNS fix
2. Mode: 0=Residuals were used to calculate the position given in the matching GGA or GNS sentence; 1=Residuals were recomputed after the GGA or GNS position was computed
3. Range residuals in meters for satellites used in the navigation solution (-99 to 99, null) See notes 1&2.
- 4 to 14. Same as #3.
15. GNSS System ID (1 to F; 1=GP, 2=GL, 3=GA, 4 to F=RESERVED)
16. Signal ID (0 to F)

Notes:

- 1) If the range residual exceeds +99.9 meters, then the decimal part is dropped, resulting in an integer (-13.7 becomes -13). The maximum value for this field is +99.
- 2) The sense or sign of the range residual is determined by the order of parameters used in the calculation.
The expected order is as follows: range residual = calculated range - measured range.
- 3) When multiple GRS sentences are being sent then their order of transmission must match the order of corresponding GSA sentences.
Listeners shall keep track of pairs of GSA and GRS sentences and discard data if pairs are incomplete.
- 4) Signal ID identifies the actual ranging signal according to the Table below.
- 5) System ID according to Table below.

GRS Table

System	System ID	Satellite ID	Signal ID	Signal Channel
GPS	1 (GP)	1 to 99 1 to 32 is reserved for GPS 33 to 64 is reserved for SBAS 65 to 99 is undefined	0	All Signals
			1	L1 C/A
			2	L1 P(Y)
			3	L1 M
			4	L2 P(Y)
			5	L2C-M
			6	L2C-L
			7	L5-I
			8	L5-Q
9 to F	Reserved			
GLONASS	2 (GL)	1 to 99 1 to 32 is undefined 33 to 64 is reserved for SBAS 65 to 99 is reserved for GLONASS	0	All Signals
			1	G1 C/A
			2	G1 P
			3	G2 C/A
			4	GLONASS (M) G2 P
5 to F	Reserved			
GALILEO	3 (GA)	1 to 99 1 to 36 is reserved for Galileo SVs 37 to 64 is reserved for Galileo SBAS 65 to 99 is undefined	0	All Signals
			1	E5a
			2	E5b
			3	E5 a+b
			4	E6-A
			5	E6-BC
			6	L1-A
			7	L1-BC
8 to F	Reserved			
Reserved	4 to F			

- GSA: GNSS DOP and Active Satellites

\$--GSA,a,x,xx,xx,xx,xx,xx,xx,xx,xx,xx,xx,x,x,x,x,x,h *hh<CR><LF>
 1 2 3 4 5 6 7

1. Mode (M=manual, forced to operate in 2=2D 3=3D mode
 A=automatic, allowed to automatically switch 2D/3D)
2. Mode (1=fix not available 2=2D 3=3D)
3. ID number of satellites used in solution (01 to 96, null)
4. PDOP (0.0 to 50.0),null
5. HDOP (0.0 to 50.0),null
6. VDOP (0.0 to 50.0),null
7. GNSS System ID (See GRS table:System ID)

- GST: GNSS Pseudorange Error Statistics

\$**GST,hhmmss.ss,x,x,x,x,x,x,x,x,x,x,x,x *hh<CR><LF>
 1 2 3 4 5 6 7 8

1. UTC time fo the GGA or GNS fix. (000000.00 to 235959.99)
2. RMS value of the standard deviation of the range inputs to the navigation process. Range inputs include pseudoranges & DGNSS corrections. (1 to 999, null)
3. Standard deviation of semi-major axis of error ellipse (meters) (0 to 655.34, null)
4. Standard deviation of semi-minor axis of error ellipse (meters) (0 to 655.34, null)
5. Orientation of semi-major axis of error ellipse (degrees from true north) (0 to 180, null)
6. Standard deviation of latitude error (meters) (0 to 999.9, null)
7. Standard deviation of longitude error (meters) (0 to 999.9, null)
8. Standard deviation of altitude error (meters) (0 to 999.9, null)

- GSV: GNSS Satellites in View

\$**GSV,x,x,xx,xx,xx,xxx,xx,_____,xx,xx,xxx,xx, h *hh<CR><LF>
 1 2 3 4 5 6 7 8 9 10

1. Total number of messages (1 to 4)
2. Message number (1 to 4)
3. Total number of satellites in view (00 to 14)
4. Satellite ID number (01 to 96),null
5. Elevation, degrees (00 to 90),null
6. Azimuth, degrees true (000 to 359),null
7. SNR(C/No) (00 to 99(dB-Hz), null when not tracking)
8. Second and third SVs
9. Fourth SV
10. Signal ID (See GRS table:Signal ID)

- HBT - Heartbeat Supervision Sentence

\$**HBT,x,x,A,x*hh<CR><LF>
 1 2 3

1. Configured repeat interval (50.0(s))(+1)
2. Equipment status (A=Normal)
3. Sequential sentence identifier (0 to 9)

- HDG: Heading, Deviation and Variation

\$**HDG,x,x,x,x,a,x,x,a*hh<CR><LF>
 1 2 3 4 5

1. Magnetic sensor heading, degrees (0.0 to 359.9)
2. Magnetic deviation, degrees (0.0 to 180.0)
3. E/W
4. Magnetic variation, degrees (0.0 to 180.00)
5. E/W

- HDM: Heading, Magnetic

```
$**HDM,x.x,M*hh<CR><LF>
      1 2
```

1. Heading, degrees (0.0 to 359.9)
2. Magnetic (M)

- HDT: Heading, True

```
$**HDT,xxx.x,T*hh<CR><LF>
      1 2
```

1. Heading, degrees (0.0 to 359.9)
2. True (T)

- HRM: Heel Angle, Roll Period and Roll Amplitude Measurement Device

```
$**HRM,hhmmss.ss,x.x,x.x,x.x,A,x.x,x.x,hhmmss.ss,x.x,x.x *hh<CR><LF>
      1      2 3 4 5 6 7      8      9 10
```

1. Actual heel angle, degrees (-89.999 to 89.999, null)
2. Roll period, seconds (0 to 99.9, null)
3. Roll amplitude, port side, degrees (0 to 89.999, null)
4. Roll amplitude, starboard side, degrees (0 to 89.999, null)
5. Status (A/V) A=Data valid, V=Data invalid
6. Roll peak hold value, port side, degrees (null)
7. Roll peak hold value, starboard side, degrees (null)
8. Peak hold value reset time (fixed at null)
9. Peak hold value reset day (fixed at null)
10. Peak hold value reset month (fixed at null)

- MSK: Receiver Interface Command

```
$**MSK,x.x,a,x.x,a,x.x,x,a *hh<CR><LF>
      1 2 3 4 5 6 7
```

1. Beacon frequency, kHz (283.5 to 325.0, null)
2. Auto/Manual frequency (See note 2) (A=Auto, M=Manual)
3. Beacon bit rate, bits/s (25, 50, 100, 150, 200, null)
4. Auto/Manual beacon bit rate (See note 2) (A=Auto, M=Manual)
5. Interval for sending \$**MSS (status) in seconds (See note 1) (Fixed at 5)
6. Channel number (See note 3) (Fixed at 1)
7. Sentence status flag (See note 4) (C - Sentence is a configuration command to change settings. A sentence without "C" is not a command.)

Notes:

- 1) When status data is not to be transmitted this field is "null".
- 2) If Auto is specified the previous field value is ignored.
- 3) Set equal to "1" or null for single channel receiver.
- 4) This field is used to indicate a sentence that is a status report of current settings or a configuration command changing settings. This field should not be null.

- POS: Device Position and Ship Dimensions Report or Confirmation Command

```
$**POS,cc,xx,a,x.x,x.x,x.x,a,x.x,x.x,a*hh<CR><LF>
      1 2 3 4 5 6 7 8 9 10
```

1. Equipment ID (GP, GL, GA, GN, HE, HN, HC)
2. Equipment number (01 to 99)
3. Position validity flag (A=Valid V=Invalid)
4. Position X-coordinate (-999.9 to 999.9)
5. Position Y-coordinate (0 to 999.9)
6. Position Z-coordinate (0 to 999.9)
7. Ship's width and length (A=Valid)
8. Ship's width (000.0 to 999.9)
9. Ship's length (000.0 to 999.9)
10. Sentence status flag (R=Sentence is status report of current settings)

- RMC: Recommended Minimum Specific GNSS Data

```
$**RMC,hhmmss.ss,A,llll.ll,a,yyyy.yy,a,x.x,x.x,ddmmyy,x.x,a,a*hh<CR><LF>
      1 2 3 4 5 6 7 8 9 10 11 12 13
```

1. UTC of position fix (000000.00 to 235959.99)
2. Status (A=data valid, V=navigation receiver warning)
3. Latitude (0000.0000 to 9000.0000)
4. N/S
5. Longitude (0000.0000 to 18000.0000)
6. E/W
7. Speed over ground, knots (0.000 to 9999.999)
8. Course over ground, degrees true (0.0 to 359.9)
9. Date (010100 to 311299)
10. Magnetic variation, degrees (0.0 to 180.0,null)
11. E/W (E/W,null)
12. Mode indicator (A= Autonomous mode, D=Differential mode, E=Estimated (DR), S= Simulator, M=Manual, N=Data not valid, P=Precise)
13. Navigational status indication (S=Safe C=Caution U=Unsafe V=Navigational status not valid)

- ROT: Rate of Turn

```
$**ROT,x.x,A *hh<CR><LF>
      1 2
```

1. Rate of turn, deg/min, "-"=bow turns to port (-9999.9 - 9999.9,null)
2. Status (A=data valid, V=data invalid)

- SRP - System Function ID Resolution Protocol

```
$--SRP,x,hhhhhhhhhhhh,c--c*hh<CR><LF>
      1 2 3
```

1. Instance number for interface redundancy (i.e. number of physical port for identical SFI), null if interface redundancy not in use. The instance numbers shall be ordinal with no skipping (1, 2, 3,...).
2. Reported MAC address used by SFI, 48bit hexadecimal number, for example 32613C4EB605
3. Reported IP address used by SFI as text string, for example 239.192.0.1

- THS: True Heading & Status

```
$**THS,x.x,a*hh<CR><LF>
  1 2
```

1. Heading, degrees True (0.0 to 359.9 null)
2. Mode indicator (A=Autonomous, E=Estimated, M=Manual input, S=Simulator V=Data not valid)

- VBW: Dual Ground/Water Speed

```
$**VBW,x.x,x.x,a,x.x,x.x,a,x.x,a,x.x,a*hh<CR><LF>
  1 2 3 4 5 6 7 8 9 10
```

1. Longitudinal water speed, knots (-999.999 to 999.999),null
2. Transverse water speed, knots (-999.999 to 999.999),null
3. Status: water speed, A=Data valid V=Data invalid
4. Longitudinal ground speed, knots (-999.999 to 999.999),null
5. Transverse ground speed, knots (-999.999 to 999.999),null
6. Status: ground speed, A=Data valid V=Data invalid
7. Stern transverse water speed, knots (-999.999 to 999.999),null
8. Status: stern water speed, A=Data valid V=Data invalid
9. Stern transverse ground speed, knots (-999.999 to 999.999),null
10. Status: stern ground speed, A=Data valid V=Data invalid

- VDR: Set and Drift

```
$**VDR,x.x,T,x.x,M,x.x,N*hh <CR><LF>
  1 2 3 4 5 6
```

1. Direction, degrees (0.0 to 359.9),null
2. T=True (fixed)
3. Direction, degrees (0.0 to 359.9),null
4. M=Magnetic (fixed)
5. Current speed (0 to 99.99),null
6. N=Knots (fixed)

- VHW: Water Speed and Heading

```
$**VHW,x.x,T,x.x,M,x.x,N,x.x,K,*hh <CR><LF>
  1 2 3 4 5 6 7 8
```

1. Heading, degrees (0.000 to 359.999, null)
2. T=True (fixed)
3. Heading, degrees (0.000 to 359.999, null)
4. M=Magnetic (fixed)
5. Speed, knots (-999.999 to 999.999, null)
6. N=Knots (fixed)
7. Speed, km/hr (-999.999 to 999.999, null)
8. K=km/hr (fixed)

- VLW: Dual Ground/Water Distance

```
$**VLW,x.x,N,x.x,N,x.x,N,x.x,N*hh<CR><LF>
  1 2 3 4 5 6 7 8
```

1. Total cumulative water distance (null)
2. N=Nautical miles
3. Water distance since reset (null)
4. N=Nautical miles
5. Total cumulative ground distance (null)
6. N=Nautical miles
7. Ground distance since reset (0.00 to 999999.99)
8. N=Nautical miles

- VTG: Course Over Ground and Ground Speed

\$**VTG,x.x,T,x.x,M,x.x,N,x.x,K,a*hh <CR><LF>
 1 2 3 4 5 6 7 8 9

1. Course over ground, degrees (0.0 to 359.999),null
2. T=True (fixed)
3. Course over ground, degrees (0.0 to 359.999),null
4. M=Magnetic (fixed)
5. Speed over ground, knots (0.000 to 999.999),null
6. N=Knots (fixed)
7. Speed over ground (0.000 to 999.999),null
8. K=km/h (fixed)
9. Mode indicator (A=Autonomous, D=Differential, E=Estimated (dead reckoning), M=Manual input, S=Simulator, N=Data not valid, P=Precise)

- XDR: Transducer Measurements

\$**XDR, a, x.x, a, c--c, a, x.x, a, c--c *hh<CR><LF>
 1 2 3 4 5 6 7 8

1. Transducer type, transducer no. 1 (C=Celcius, fixed)
2. Measurement data, transducer no. 1 (-50.00 to 99.99)
3. Units of measure (C=Celcuis, fixed)
4. Transducer no.1 ID (AIRT, fixed)
5. Transducer type, transducer no. 2 (P=Pressure, fixed)
6. Measurement data, transducer no. 2 (0.00 to 120000.00)
7. Units of measure (P=Pascal, fixed)
8. Transducer no.2 ID (AIRP, fixed)

- ZDA: Time and date

\$--ZDA,hhmmss.ss,xx,xx,xxxx,xx,xx,*hh<CR><LF>
 1 2 3 4 5 6

1. UTC (000000 to 235959)
2. Day (01 to 31, UTC)
3. Month (01 to 12, UTC)
4. Year (0000 to 9999, UTC)
5. Local zone, hours (-13 to ±13)
6. Local zone, minutes (00 to ±59)

APPX. 8 PARTS LIST/LOCATION

Parts List

This equipment contains complex modules in which fault diagnosis and repair down to component level are not practical (IMO A.694(17)/8.3.1). Only some discrete components are used. FURUNO Electric Co., Ltd. believes identifying these components is of no value for shipboard maintenance; therefore, they are not listed in the manual. Major modules can be located on the parts location figures below.

FURUNO	Model	SC-70/SC-130
ELECTRICAL PARTS LIST	Unit	DISPLAY UNIT, JUNCTION BOX,
TYPE, NAME	LOCATION	
PRINTED CIRCUIT BOARD		
20P8200E, MAIN	DISPLAY UNIT SC-702	
05P0894A, C-IF	DISPLAY UNIT SC-702	
20P8232, MAIN	JUNCTION BOX SC-701	
20P8233, TB_PWR	JUNCTION BOX SC-701	
20P8229A, LAN_CNV	JUNCTION BOX SC-701	

PCB locations for SC-701

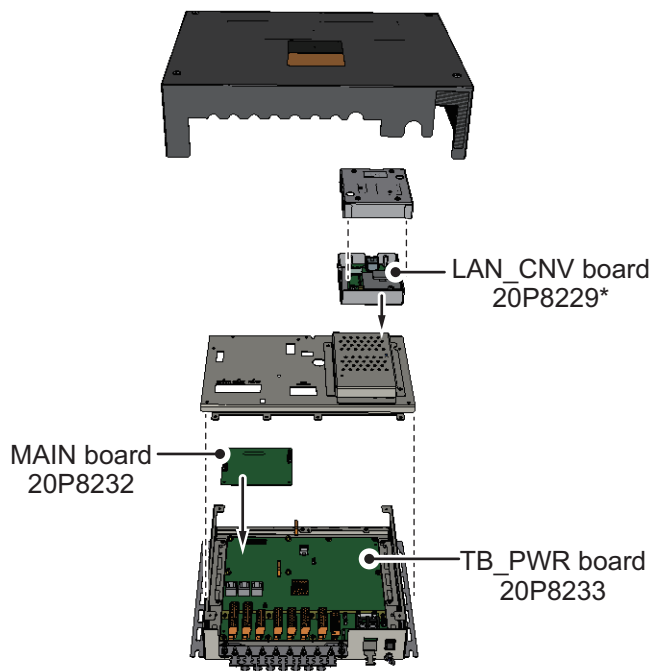

PCB locations for SC-702

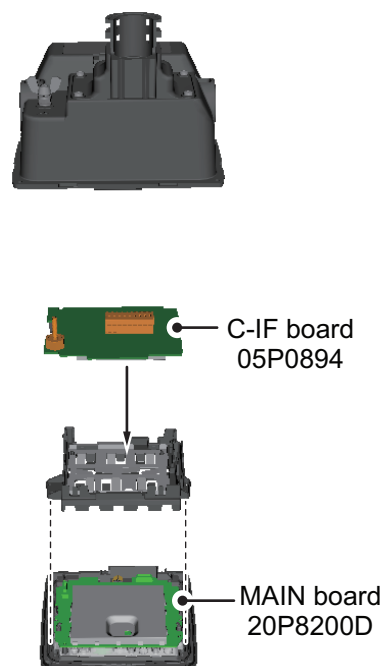

*: Optional LAN to Coax conversion kit.

Note: SC-701 and SC-702 are not shown to scale in this figure.

FURUNO	Model	SC-703
ELECTRICAL PARTS LIST	Unit	ANTENNA UNIT
TYPE, NAME	LOCATION	
PRINTED CIRCUIT BOARD		
20P8228A, MAIN	ANTENNA UNIT SC-703	
20P8222A, GNSS_LNA	ANTENNA UNIT SC-703	
20P8229B, LAN_CNV	ANTENNA UNIT SC-703	
20P8230, SUB_IMU	ANTENNA UNIT SC-703	

PCB locations for SC-703

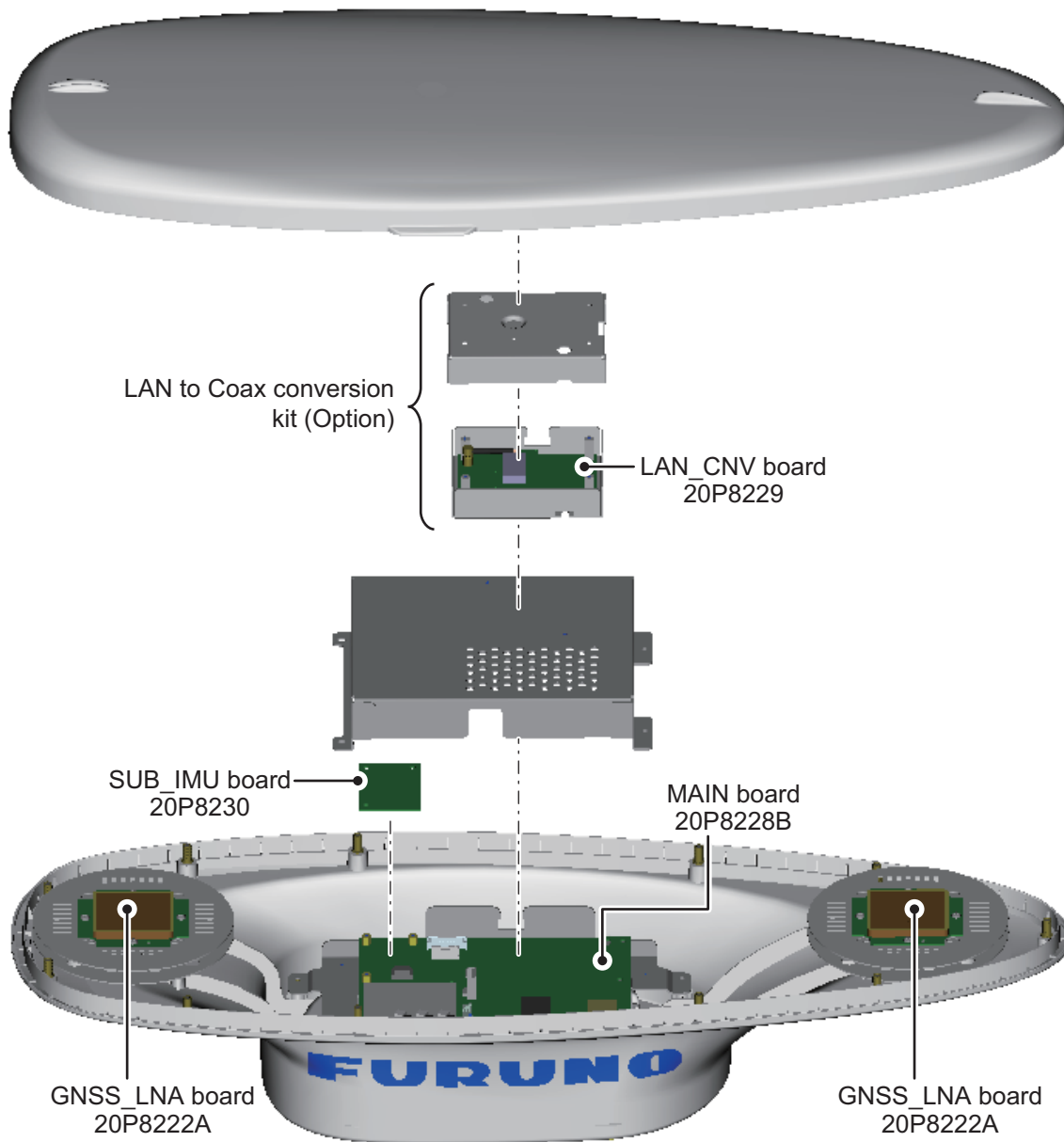

FURUNO ELECTRICAL PARTS LIST	Model	SC-1303
	Unit	ANTENNA UNIT
TYPE, NAME	LOCATION	
PRINTED CIRCUIT BOARD		
20P8228B, MAIN	ANTENNA UNIT SC-1303	
20P8222A, GNSS LNA	ANTENNA UNIT SC-1303	
20P8229B, LAN_CNV	ANTENNA UNIT SC-1303	
20P8230, SUB_IMU	ANTENNA UNIT SC-1303	

PCB locations for SC-1303

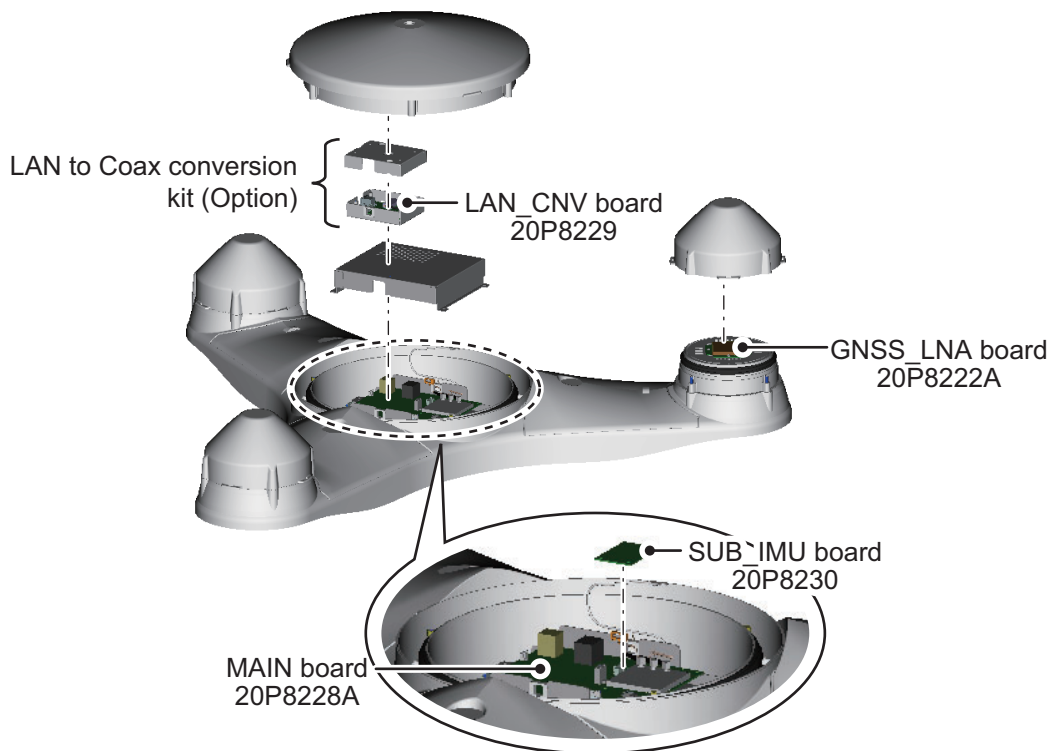

APPX. 9 JIS CABLE GUIDE

Cables listed in the manual are usually shown as Japanese Industrial Standard (JIS). Use the following guide to locate an equivalent cable locally.

JIS cable names may have up to 6 alphabetical characters, followed by a dash and a numerical value (example: DPYC-2.5).

For core types D and T, the numerical designation indicates the *cross-sectional Area (mm²)* of the core wire(s) in the cable.

For core types M and TT, the numerical designation indicates the *number of core wires* in the cable.

1. Core Type

D: Double core power line

T: Triple core power line

M: Multi core

TT: Twisted pair communications
(1Q=quad cable)

2. Insulation Type

P: Ethylene Propylene Rubber

3. Sheath Type

Y: PVC (Vinyl)

4. Armor Type

C: Steel

5. Sheath Type

Y: Anticorrosive vinyl sheath

6. Shielding Type

SLA: All cores in one shield, plastic tape w/aluminum tape

-SLA: Individually shielded cores, plastic tape w/aluminum tape

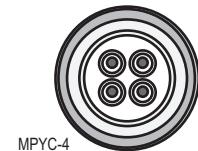
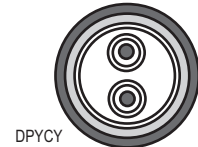

EX: ^{1 2 3 4 5 6} TTYCYSLA - 4
Designation type | # of twisted pairs

EX: ^{1 2 3 4} MPYC - 4
Designation type | # of cores

The following reference table lists gives the measurements of JIS cables commonly used with Furuno products:

Type	Core Area	Core Diameter	Cable Diameter	Type	Core Area	Core Diameter	Cable Diameter
DPYC-1.5	1.5mm ²	1.56mm	11.7mm	TTYCSLA-1	0.75mm ²	1.11mm	9.4mm
DPYC-2.5	2.5mm ²	2.01mm	12.8mm	TTYCSLA-1T	0.75mm ²	1.11mm	10.1mm
DPYC-4	4.0mm ²	2.55mm	13.9mm	TTYCSLA-1Q	0.75mm ²	1.11mm	10.8mm
DPYC-6	6.0mm ²	3.12mm	15.2mm	TTYCSLA-4	0.75mm ²	1.11mm	15.7mm
DPYC-10	10.0mm ²	4.05mm	17.1mm	TTYCY-1	0.75mm ²	1.11mm	11.0mm
DPYCY-1.5	1.5mm ²	1.56mm	13.7mm	TTYCY-1T	0.75mm ²	1.11mm	11.7mm
DPYCY-2.5	2.5mm ²	2.01mm	14.8mm	TTYCY-1Q	0.75mm ²	1.11mm	12.6mm
DPYCY-4	4.0mm ²	2.55mm	15.9mm	TTYCY-4	0.75mm ²	1.11mm	17.7mm
MPYC-2	1.0mm ²	1.29mm	10.0mm	TTYCY-4SLA	0.75mm ²	1.11mm	19.5mm
MPYC-4	1.0mm ²	1.29mm	11.2mm	TTYCYSLA-1	0.75mm ²	1.11mm	11.2mm
MPYC-7	1.0mm ²	1.29mm	13.2mm	TTYCYSLA-4	0.75mm ²	1.11mm	17.9mm
MPYC-12	1.0mm ²	1.29mm	16.8mm				
TPYC-1.5	1.5mm ²	1.56mm	12.5mm				
TPYC-2.5	2.5mm ²	2.01mm	13.5mm				
TPYC-4	4.0mm ²	2.55mm	14.7mm				
TPYCY-1.5	1.5mm ²	1.56mm	14.5mm				
TPYCY-2.5	2.5mm ²	2.01mm	15.5mm				
TPYCY-4	4.0mm ²	2.55mm	16.9mm				

**SPECIFICATIONS OF SATELLITE COMPASS
SC-70/130**

1 GENERAL

- 1.1 Receiving frequency 1575.42 MHz (GPS/GALILEO), 1602.5625 MHz (GLONASS)
- 1.2 Tracking code C/A code (GPS), E1B (GALILEO), L1OF (GLONASS)
- 1.3 Positional accuracy (dependent on ionospheric activity and multipath)
 - GPS 5 m approx. (2drms, HDOP<4)
 - DGPS 4 m approx. (2drms, HDOP<4)
 - WAAS 3 m approx. (2drms, HDOP<4)
 - MSAS 4 m approx. (2drms, HDOP<4)
- 1.4 Ship's speed accuracy (SOG)
 - 0.2 kn rms (tracking satellites 3 or 4)
 - 0.02 kn rms (tracking satellites 5 or more)
- 1.5 Ship's speed accuracy (VBW, speed on ground)
 - 2.0% of ship's speed or 0.2 kn whichever is the greater (tracking satellites 3 or 4)
 - 0.2% of ship's speed or 0.02 kn whichever is the greater (tracking satellites 5 or more, at antenna position)
 - 0.2% of ship's speed or 0.08 kn rms (tracking satellites 5 or more, at another position)
- 1.6 Course accuracy
 - SC-70 0.4° RMS
 - SC-130 0.25° RMS
- 1.7 Course resolution 0.1°, 0.01° or 0.001° (select from menu)
- 1.8 Attitude resolution 0.1°, 0.01° or 0.001° (select from menu)
- 1.9 Rate of turn 0.1°/s, 0.01°/s or 0.001°/s (select from menu)
- 1.10 Tracking bearing 45°/s
- 1.11 Position fixing time 90 s approx. (typical)
- 1.12 Attitude accuracy Pitch/ Roll: 0.4° RMS
- 1.13 Heave accuracy 5 cm (1σ)

2 DISPLAY UNIT

- 2.1 Screen 4.3-inch color LCD, 95.04 mm (W) x 87.12 mm (H)
- 2.2 Resolution 480 x 272 dots (WQVGA)
- 2.3 Brilliance 600 cd/m² typical
- 2.4 Contrast 17 levels
- 2.5 Display mode Heading, Nav data, Rate of turn and Speed (Non-IMO mode only)
- 2.6 Visible distance 0.65 m nominal

3 INTERFACE (JUNCTION BOX)

- 3.1 Number of ports (junction box)
 - IEC61162 (NMEA0183) IEC61162-2: 1 port, IEC61162-1: 8 ports (I/O: 4, O: 4)
 - External beacon input (DATA5 port):
RTCM SC-104 V2.3 (RS-485), ITU-R M823
 - NMEA2000 1 port
 - AD-10 4 ports, for heading output
 - RS-485 1 port, for display unit connection

LAN	2 ports, Ethernet, 100Base-TX, RJ45 connector, IGMPv2 acceptable (for IEC61162-450 and maintenance)
USB	1 port for maintenance
3.2 Data sentences	
DATA ports	
Input	ACK, ACM, ACN, HBT, HDT, MSK, MSS, THS, VBW* ² , VDR* ²
Output	ALC, ALF, ALR, ARC, DTM, GBS, GGA, GLL, GNS, GRS, GSA, GST, GSV, HBT, HDG* ² , HDM* ² , HDT* ¹ , HRM* ² , MSK, POS, RMC, ROT, THS, VBW* ² , VDR* ² , VHW* ² , VLW* ² , VTG, XDR* ² , ZDA
NETWORK port	
Input	ACK, ACM, ACN, HBT, SRP
Output	ALC, ALF, ALR, ARC, DTM, GBS, GGA, GLL, GNS, GRS, GSA, GST, GSV, HBT, HDG, HDM, HDT* ¹ , HRM* ² , POS, RMC, ROT, SRP, THS, VBW* ² , VDR* ² , VHW* ² , VLW* ² , VTG, XDR* ² , ZDA
	* ¹ : Not used for new SOLAS vessels.
	* ² : for Non-IMO types only.
3.3 Output proprietary sentences	
PFEC	GPatt, GPhve, GPimu, pidat, pireq
3.4 PGN	
Input	059392/904, 060928, 061184, 126208/720/996
Output	059392/904, 060928, 061184, 065280, 126208/464/720/992/996, 127250/251/252/257/258, 129025/026/029/033/044/291/539/540/545/547, 130310/312/314/316/577/578/822/823/842/843/845/846
3.5 IEC61162-450 transmission group (datagram type: UdPbC only)	
Input	MISC, SATD, NAVD, NETA, PROP
Output	Arbitrary (default: SATD)
3.6 Other network function excepted IEC61162-450	NTP, HTTP

4 POWER SUPPLY

4.1 Junction box	12-24 VDC: 2.1-1.1 A (included antenna unit and display unit)
4.2 AC/DC power supply unit (option)	
PR-240	100-115/220-230 VAC, 1 phase, 50/60Hz and 24VDC for back-up
PR-241	100-230 VAC, 1 phase, 50-60 Hz and 24 VDC for back-up

5 ENVIRONMENTAL CONDITIONS

5.1 Ambient temperature	
Antenna unit	-25°C to +55°C (storage: -25°C to +70°C)
Display unit/ Junction box	-15°C to +55°C
5.2 Relative humidity	95% or less at +40°C
5.3 Degree of protection	
Antenna unit	IP56
Display unit	IP22 (IP35: option)
Junction box	IP20 (IP22: bulkhead mount)
5.4 Vibration	IEC 60945 Ed.4

6 UNIT COLOR

- 6.1 Antenna unit N9.5
- 6.2 Display unit/ Junction box N2.5

This page is intentionally left blank.

PACKING LIST
SC-703-A-*, SC-703-A-*-HK

20B1-X-9857 -3 1/1 A-1

NAME	UNIT	OUTLINE	DESCRIPTION/CODE No.	Q'TY
空中線部 ANTENNA UNIT			SC-703-A-*	1
			000-037-295-00 **	
工事材料 INSTALLATION MATERIALS				
工事材料 INSTALLATION MATERIALS			CP20-04201	1
			001-459-750-00 **	

コード番号末尾の["*"]は、選択品の代表コードを表します。
CODE NUMBER ENDING WITH "*" INDICATES THE CODE NUMBER OF REPRESENTATIVE MATERIAL.

(略図の寸法は、参考値です。DIMENSIONS IN DRAWING FOR REFERENCE ONLY.)

C7282-207-D

PACKING LIST
SC-1303-A-*, SC-1303-A-*-HK

20B1-X-9859 -2 1/1 A-2

NAME	UNIT	OUTLINE	DESCRIPTION/CODE No.	Q'TY
空中線部 ANTENNA UNIT			SC-1303-A-*	1
			000-037-299-00 **	
工事材料 INSTALLATION MATERIALS				
工事材料 INSTALLATION MATERIALS			CP20-04202	1
			001-459-760-00 **	

コード番号末尾の["*"]は、選択品の代表コードを表します。
CODE NUMBER ENDING WITH "*" INDICATES THE CODE NUMBER OF REPRESENTATIVE MATERIAL.

(略図の寸法は、参考値です。DIMENSIONS IN DRAWING FOR REFERENCE ONLY.)

C7283-201-C

PACKING LIST
SC-701-A-*, SC-701-A-*-HK-*

20B1-X-9851 -2 1/1 A-3

NAME	UNIT	OUTLINE	DESCRIPTION/CODE	Q'TY
接続箱 JUNCTION BOX			SC-701-A-*	1
			000-037-210-00 **	
予備品 SPARE PARTS				
予備品 SPARE PARTS			SP20-01801	1
			001-474-090-00 **	
工事材料 INSTALLATION MATERIALS				
工事材料 INSTALLATION MATERIALS			CP20-04001	1
			001-459-800-00 **	

コード番号末尾の["*"]は、選択品の代表コードを表します。
CODE NUMBER ENDING WITH "*" INDICATES THE CODE NUMBER OF REPRESENTATIVE MATERIAL.

(略図の寸法は、参考値です。DIMENSIONS IN DRAWING FOR REFERENCE ONLY.)

C7282-201-C

PACKING LIST
SC-702-A-*, SC-702-A-*-HK

20B1-X-9863 -5 1/1 A-4

NAME	UNIT	OUTLINE	DESCRIPTION/CODE No.	Q'TY
表示部 DISPLAY UNIT			SC-702-A-*	1
			000-037-269-00 **	
付属品 ACCESSORIES				
付属品 ACCESSORIES			FP19-01201	1
			001-033-760-00 **	
工事材料 INSTALLATION MATERIALS				
工事材料 INSTALLATION MATERIALS			CP20-04101	1
			001-521-370-00 **	
図書 DOCUMENT				
取扱説明書 OPERATOR'S MANUAL			OM*-72820-*	1
			000-100-057-2* **	

コード番号末尾の["*"]は、選択品の代表コードを表します。
CODE NUMBER ENDING WITH "*" INDICATES THE CODE NUMBER OF REPRESENTATIVE MATERIAL.

(略図の寸法は、参考値です。DIMENSIONS IN DRAWING FOR REFERENCE ONLY.)

C7282-211-F

PACKING LIST

20B1-X-9854 -5 1/1 A-5

SC-702-A-1/3, SC-702-A-1/3-HK

NAME	UNIT	OUTLINE	DESCRIPTION/CODE No.	Q'TY
ユニット UNIT				
表示部 DISPLAY UNIT			SC-702-A-1/3 000-037-273-00 **	1
付属品 ACCESSORIES				
付属品 ACCESSORIES			FP19-01201 001-033-760-00 **	1
工事材料 INSTALLATION MATERIALS				
ケーブル組品 CABLE ASSEMBLY			Z-#26X2P+0.3SQX1PL10 000-192-276-10 (*)	1
ケーブル組品 CABLE ASSEMBLY			Z-#26X2P+0.3SQX1PL30 000-192-277-10 (*)	1
工事材料 INSTALLATION MATERIALS			CP20-04101 001-521-370-00 **	1
図書 DOCUMENT				
取扱説明書 OPERATOR'S MANUAL			OM#-72820-* 000-100-057-2* **	1

1.コード番号末尾の(*)は、選択品の代表コードを表します。
CODE NUMBER ENDING WITH "*" INDICATES THE CODE NUMBER OF REPRESENTATIVE MATERIAL.
2.(*)は、それぞれ仕様選択品を表します。
(*INDICATE SPECIFICATION SELECTIVE ITEM.

C7282-Z04-F

(略図の寸法は、参考値です。 DIMENSIONS IN DRAWING FOR REFERENCE ONLY.)

FURUNO

CODE NO. 001-514-470-00 20B1-X-9410 -1
TYPE CP20-04001 1/1

番号 NO.	名称 NAME	略図 OUTLINE	型名/規格 DESCRIPTIONS	数量 Q'TY	用途/備考 REMARKS
1	ワイヤチューブ F2 IRAX TUBE		3.0X0.4 4ヶ口 #500M# CODE NO. 000-198-887-10	3	
2	+selfタッピング 1ヶ口 SELF-TAPPING SCREW		5X20 SUS304 CODE NO. 000-162-608-10	4	
3	ケーブルタイ CABLE TIE		CV-150N CODE NO. 000-162-186-10	32	

(略図の寸法は、参考値です。 DIMENSIONS IN DRAWING FOR REFERENCE ONLY.)

FURUNO ELECTRIC CO., LTD.

CN

C7282-M10-B

FURUNO

CODE NO. 001-516-680-00 20B1-X-9303-0 1/1
TYPE SP20-01801 BOX NO. P

SHIP NO.	SPARE PARTS LIST FOR	U S E	SETS PER VESSEL		
ITEM NO.	NAME OF PART	OUTLINE	DWG. NO. OR TYPE NO.	QUANTITY	REMARKS/CODE NO.
				PER SET	PER VESSEL
1	ガラス管 GLASS TUBE FUSE		F080-A 125V 3A PBF	1	1 3 000-155-850-10
2	ガラス管 GLASS TUBE FUSE		F080-B 125V 0.3A PBF	1	1 3 000-176-821-10
MFR'S NAME FURUNO ELECTRIC CO., LTD. DWG. NO. C7282-P02-A CN 1/1					

(略図の寸法は、参考値です。 DIMENSIONS IN DRAWING FOR REFERENCE ONLY.)

A-7

FURUNO

CODE NO. 001-521-480-00 20B1-X-9414 -0
TYPE CP20-04101 1/1

番号 NO.	名称 NAME	略図 OUTLINE	型名/規格 DESCRIPTIONS	数量 Q'TY	用途/備考 REMARKS
1	F_MOUNT CUSHION		20-032-1064-1 CODE NO. 100-357-181-10	1	
2	ケーブルパッキン CABLE GASKET		20-037-2104-0 CODE NO. 100-419-500-10	1	
3	+selfタッピング 1ヶ口 SELF-TAPPING SCREW		3X20 SUS304 CODE NO. 000-163-884-10	4	
4	+selfタッピング 1ヶ口 SELF-TAPPING SCREW		5X20 SUS304 CODE NO. 000-162-608-10	4	
5	ケーブルタイ CABLE TIE		CV-150B CODE NO. 000-167-183-10	3	

(略図の寸法は、参考値です。 DIMENSIONS IN DRAWING FOR REFERENCE ONLY.)

FURUNO ELECTRIC CO., LTD.











CN

C7282-M13-A

A-8

FURUNO

CODE NO.	001-514-460-00	2081-X-9411 -2
TYPE	CP20-04201	1/1

工事材料表		略 図		型名/規格		数量		用途/備考	
番号	名称	略 図	型名/規格	数量	用途/備考	番号	名称	略 図	型名/規格
NO.	NAME	OUTLINE	DESCRIPTIONS	QTY	REMARKS	NO.	NAME	OUTLINE	DESCRIPTIONS
1	鳥除け BIRD DETERRENT		20-024-3101-4 CODE NO. 100-315-304-10	4		1	鳥除け BIRD DETERRENT		20-024-3101-4 CODE NO. 100-315-304-10
2	六角ナット 19 $\frac{1}{2}$ HEX. NUT		M10 SUS304 CODE NO. 000-166-475-10	8		2	六角ナット 19 $\frac{1}{2}$ HEX. NUT		M10 SUS304 CODE NO. 000-166-475-10
3	バネ金 SPRING WASHER		M10 SUS304 CODE NO. 000-167-233-10	4		3	バネ金 SPRING WASHER		M10 SUS304 CODE NO. 000-167-233-10
4	平金 FLAT WASHER		M10 SUS316L CODE NO. 000-167-416-10	4		4	平金 FLAT WASHER		M10 SUS316L CODE NO. 000-167-416-10
5	接着剤保証 ADHESIVE		TB5211 50G CODE NO. 001-517-370-00	1		5	接着剤保証 ADHESIVE		TB5211 50G CODE NO. 001-517-370-00











(略図の寸法は、参考値です。 DIMENSIONS IN DRAWING FOR REFERENCE ONLY.)

FURUNO ELECTRIC CO., LTD. CN

C7282-M11-C

FURUNO

CODE NO.	001-514-570-00	2081-X-9412 -2
TYPE	CP20-04202	1/1

工事材料表		略 図		型名/規格		数量		用途/備考	
番号	名称	略 図	型名/規格	数量	用途/備考	番号	名称	略 図	型名/規格
NO.	NAME	OUTLINE	DESCRIPTIONS	QTY	REMARKS	NO.	NAME	OUTLINE	DESCRIPTIONS
1	鳥除け BIRD DETERRENT		20-024-3101-4 CODE NO. 100-315-304-10	7		1	鳥除け BIRD DETERRENT		20-024-3101-4 CODE NO. 100-315-304-10
2	六角ナット 19 $\frac{1}{2}$ HEX. NUT		M10 SUS304 CODE NO. 000-166-475-10	8		2	六角ナット 19 $\frac{1}{2}$ HEX. NUT		M10 SUS304 CODE NO. 000-166-475-10
3	バネ金 SPRING WASHER		M10 SUS304 CODE NO. 000-167-233-10	4		3	バネ金 SPRING WASHER		M10 SUS304 CODE NO. 000-167-233-10
4	平金 FLAT WASHER		M10 SUS316L CODE NO. 000-167-416-10	4		4	平金 FLAT WASHER		M10 SUS316L CODE NO. 000-167-416-10
5	接着剤保証 ADHESIVE		TB5211 50G CODE NO. 001-517-370-00	1		5	接着剤保証 ADHESIVE		TB5211 50G CODE NO. 001-517-370-00







(略図の寸法は、参考値です。 DIMENSIONS IN DRAWING FOR REFERENCE ONLY.)

FURUNO ELECTRIC CO., LTD. CN

C7283-M02-C

FURUNO

CODE NO.	000-033-318-00	2081-X-9405 -0
TYPE	CP20-04300	1/1

工事材料表		略 図		型名/規格		数量		用途/備考	
番号	名称	略 図	型名/規格	数量	用途/備考	番号	名称	略 図	型名/規格
NO.	NAME	OUTLINE	DESCRIPTIONS	QTY	REMARKS	NO.	NAME	OUTLINE	DESCRIPTIONS
1	モジュラコネクタ MODULAR CONNECTOR		MFSS88-C CODE NO. 000-166-344-10	1		1	モジュラコネクタ MODULAR CONNECTOR		MFSS88-C CODE NO. 000-166-344-10
2	コネクタ CONNECTOR		FBU-RJ=PLUG=ASSY CODE NO. 000-192-316-10	1		2	コネクタ CONNECTOR		FBU-RJ=PLUG=ASSY CODE NO. 000-192-316-10
3	LANケーブル (CAT5E) CABLE ASSEMBLY		DT1CSE3G50SLABV040T CODE NO. 001-470-930-00	1		3	LANケーブル (CAT5E) CABLE ASSEMBLY		DT1CSE3G50SLABV040T CODE NO. 001-470-940-00







(略図の寸法は、参考値です。 DIMENSIONS IN DRAWING FOR REFERENCE ONLY.)

FURUNO ELECTRIC CO., LTD.

C7282-M05-A

FURUNO

CODE NO.	000-033-319-00	2081-X-9406 -0
TYPE	CP20-04310	1/1

工事材料表		略 図		型名/規格		数量		用途/備考	
番号	名称	略 図	型名/規格	数量	用途/備考	番号	名称	略 図	型名/規格
NO.	NAME	OUTLINE	DESCRIPTIONS	QTY	REMARKS	NO.	NAME	OUTLINE	DESCRIPTIONS
1	モジュラコネクタ MODULAR CONNECTOR		MFSS88-C CODE NO. 000-166-344-10	1		1	モジュラコネクタ MODULAR CONNECTOR		MFSS88-C CODE NO. 000-166-344-10
2	コネクタ CONNECTOR		FBU-RJ=PLUG=ASSY CODE NO. 000-192-316-10	1		2	コネクタ CONNECTOR		FBU-RJ=PLUG=ASSY CODE NO. 000-192-316-10
3	LANケーブル (CAT5E) CABLE ASSEMBLY		DT1CSE3G50SLABV040T CODE NO. 001-470-940-00	1		3	LANケーブル (CAT5E) CABLE ASSEMBLY		DT1CSE3G50SLABV040T CODE NO. 001-470-930-00



(略図の寸法は、参考値です。 DIMENSIONS IN DRAWING FOR REFERENCE ONLY.)

FURUNO ELECTRIC CO., LTD.

C7282-M06-A

FURUNO

CODE NO.	000-033-320-00	20B1-X-9407 -0
TYPE	CP20-04320	1/1

工事材料表					
INSTALLATION MATERIALS					
番号 NO.	名称 NAME	略図 OUTLINE	型名/規格 DESCRIPTIONS	数量 QTY	用途/備考 REMARKS
1	モジュラコネクタ MODULAR CONNECTOR		MPSS88-C CODE NO. 000-186-044-10	1	
2	コネクタ CONNECTOR		FRU-RJ-PLUG-ASSY CODE NO. 000-192-316-10	1	
3	LANケーブル(CAT5E) CABLE ASSEMBLY		DT1CSE350SLABVCV50T CODE NO. 001-470-950-00	1	

(略図の寸法は、参考値です。 DIMENSIONS IN DRAWING FOR REFERENCE ONLY.)

FURUNO ELECTRIC CO., LTD.

C7282-M07-A

FURUNO

CODE NO.	000-035-430-00	20B1-X-9404 -3
TYPE	CP20-04370	1/1

工事材料表					
INSTALLATION MATERIALS					
番号 NO.	名称 NAME	略図 OUTLINE	型名/規格 DESCRIPTIONS	数量 QTY	用途/備考 REMARKS
1	LANケーブル(CAT5E) CABLE ASSEMBLY		DT1CSE350SLABVCV10T CODE NO. 001-521-010-00	1	選択 TO BE SELECTED
2	LANケーブル(CAT5E) CABLE ASSEMBLY		DT1CSE350SLABVCV15T CODE NO. 001-521-010-00	1	選択 TO BE SELECTED
3	LANケーブル(CAT5E) CABLE ASSEMBLY		EDT1CSE350SLABW 815T CODE NO. 001-470-960-00	1	選択 TO BE SELECTED
4	LANケーブル(CAT5E) CABLE ASSEMBLY		EDT1CSE350SLABW 830T CODE NO. 001-470-970-00	1	選択 TO BE SELECTED
5	ケーブル(フレッチ) CABLE ASSEMBLY		S-17209-L10 CODE NO. 001-524-090-00	1	選択 TO BE SELECTED
6	ケーブル(フレッチ) CABLE ASSEMBLY		S-17209-L15 CODE NO. 001-524-100-00	1	選択 TO BE SELECTED



(略図の寸法は、参考値です。 DIMENSIONS IN DRAWING FOR REFERENCE ONLY.)

FURUNO ELECTRIC CO., LTD.

C7282-M02-D

FURUNO

CODE NO.	000-033-324-00	20B1-X-9409 -0
TYPE	CP20-04360	1/1

工事材料表					
INSTALLATION MATERIALS					
番号 NO.	名称 NAME	略図 OUTLINE	型名/規格 DESCRIPTIONS	数量 QTY	用途/備考 REMARKS
1	モジュラコネクタ MODULAR CONNECTOR		MPSS88-C CODE NO. 000-186-044-10	1	
2	コネクタ CONNECTOR		FRU-RJ-PLUG-ASSY CODE NO. 000-192-316-10	1	
3	LANケーブル(CAT5E) CABLE ASSEMBLY		EDT1CSE350SLABW 830T CODE NO. 001-470-990-00	1	



(略図の寸法は、参考値です。 DIMENSIONS IN DRAWING FOR REFERENCE ONLY.)

FURUNO ELECTRIC CO., LTD.

C7282-M09-A

FURUNO

CODE NO.	000-035-430-00	20B1-X-9417 -2
TYPE	CP20-04370	1/1

工事材料表					
INSTALLATION MATERIALS					
番号 NO.	名称 NAME	略図 OUTLINE	型名/規格 DESCRIPTIONS	数量 QTY	用途/備考 REMARKS
1	LANケーブル(CAT5E) CABLE ASSEMBLY		DT1CSE350SLABVCV10T CODE NO. 000-195-119-12	1	
2	コネクタ CONNECTOR		FRU-RJ-PLUG-ASSY CODE NO. 000-192-316-10	1	
3	モジュラコネクタ MODULAR CONNECTOR		MPSS88-C CODE NO. 000-186-044-10	1	



(略図の寸法は、参考値です。 DIMENSIONS IN DRAWING FOR REFERENCE ONLY.)

FURUNO ELECTRIC CO., LTD.

C7282-M16-C

FURUNO

CODE NO.	000-035-431-00	20B1-X-9418 -2
TYPE	CP20-04380	1/1

工事材料表					
INSTALLATION MATERIALS					
番号 NO.	名称 NAME	略図 OUTLINE	型名/規格 DESCRIPTIONS	数量 QTY	用途/備考 REMARKS
1	LANケーブル(CAT5E) CABLE ASSEMBLY	 L=15M	DT10S630SLABVQV15T CODE NO. 000-195-120-12	1	
2	コネクタ(モジュラー) CONNECTOR		FRU-RJ-PLUG-ASSY CODE NO. 000-192-316-10	1	
3	コネクタ(モジュラー) MODULAR CONNECTOR	 12 23 48	MPSS88-C CODE NO. 000-166-044-10	1	



(略図の寸法は、参考値です。 DIMENSIONS IN DRAWING FOR REFERENCE ONLY.)

FURUNO ELECTRIC CO., LTD.

C7282-M17-C

FURUNO

CODE NO.	000-035-508-00	20B1-X-9419 -0
TYPE	CP20-04520	1/1

工事材料表					
INSTALLATION MATERIALS					
番号 NO.	名称 NAME	略図 OUTLINE	型名/規格 DESCRIPTIONS	数量 QTY	用途/備考 REMARKS
1	ケーブル(カテゴリ5C) CABLE ASSEMBLY	 L=10M	S-17210-L10 CODE NO. 000-195-269-10	1	
2	コネクタ(モジュラー) MODULAR CONNECTOR	 23 12	MPSS88-C CODE NO. 000-166-044-10	1	
3	コネクタ(モジュラー) CONNECTOR		FRU-RJ-PLUG-ASSY CODE NO. 000-192-316-10	1	



(略図の寸法は、参考値です。 DIMENSIONS IN DRAWING FOR REFERENCE ONLY.)

FURUNO ELECTRIC CO., LTD.

C7282-M18-A

FURUNO

CODE NO.	000-035-509-00	20B1-X-9420 -1
TYPE	CP20-04530	1/1

工事材料表					
INSTALLATION MATERIALS					
番号 NO.	名称 NAME	略図 OUTLINE	型名/規格 DESCRIPTIONS	数量 QTY	用途/備考 REMARKS
1	ケーブル(カテゴリ5C) CABLE ASSEMBLY	 L=15M	S-17210-L15 CODE NO. 000-195-270-10	1	
2	コネクタ(モジュラー) MODULAR CONNECTOR	 23 12	MPSS88-C CODE NO. 000-166-044-10	1	
3	コネクタ(モジュラー) CONNECTOR		FRU-RJ-PLUG-ASSY CODE NO. 000-192-316-10	1	

(略図の寸法は、参考値です。 DIMENSIONS IN DRAWING FOR REFERENCE ONLY.)

FURUNO ELECTRIC CO., LTD.

C7282-M19-B

表1 TABLE 1

寸法区分 (mm) DIMENSION	公差 (mm) TOLERANCE
L ≤ 50	±1.5
50 < L ≤ 100	±2.5
100 < L ≤ 500	±3

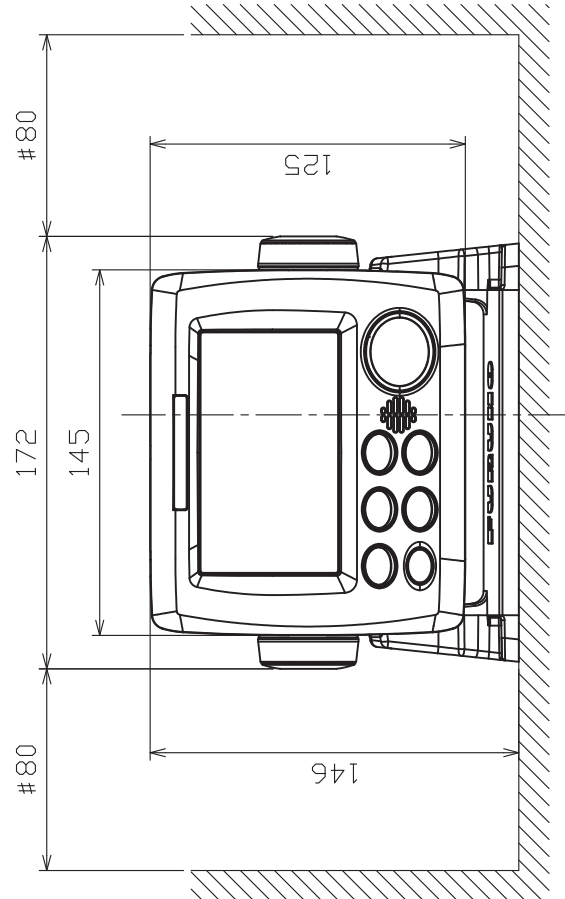
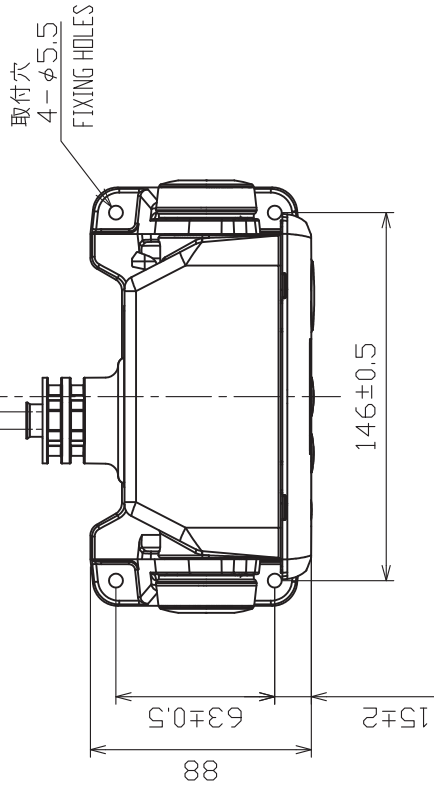
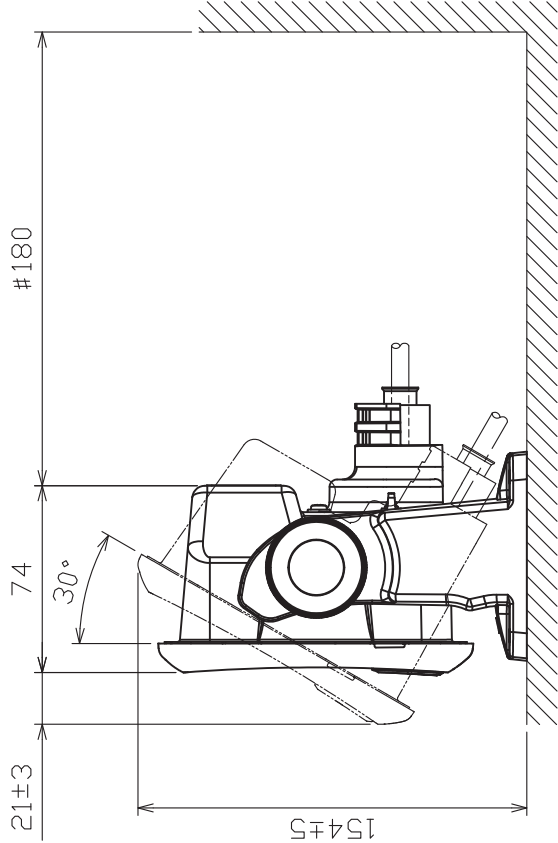
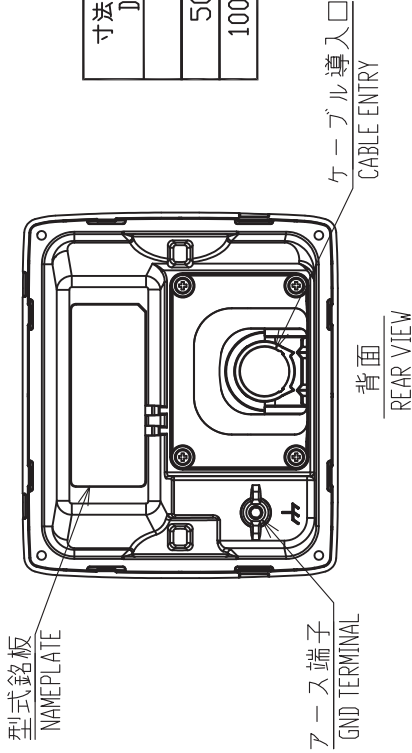

注 記

- 1) 指定外寸法公差は表 1 による。
- 2) # 印寸法は、最小サービスクリアランスとする。
- 3) 取付用ネジはトラスター呼び径5×20を使用のこと。

NOTE

1. TABLE 1 INDICATES TOLERANCE OF DIMENSIONS WHICH IS NOT SPECIFIED.
2. # MINIMUM SERVICE CLEARANCE.
3. USE TAPPING SCREWS φ5×20 FOR FIXING THE UNIT.

DRAWN	26/Dec/2017	I. YAMASAKI	TITLE	SC-702
CHECKED	26/Dec/2017	H. MAKI	名称	表示部 (卓上装備)
APPROVED	27/Dec/2017	H. MAKI	外寸図	
SCALE	1/3	MASS 0.70 kg 質量はケーブルを含みません。 MASS DOES NOT INCLUDE CABLE.	NAME	DISPLAY UNIT (TABLETOP MOUNT)
FIG.No.	C7282-601-B	REF.No.	20-037-200G-3	OUTLINE DRAWING



表1 TABLE 1

寸法区分 (mm) DIMENSION	公差 (mm) TOLERANCE
L ≤ 50	±1.5
50 < L ≤ 100	±2.5
100 < L ≤ 500	±3

注記

- 1) 指定外寸法公差は表1による。
- 2) #印寸法は、最小サービス空間寸法とする。
- 3) 取付用ネジはナベタツピンネジ呼び径3×20を使用のこと。

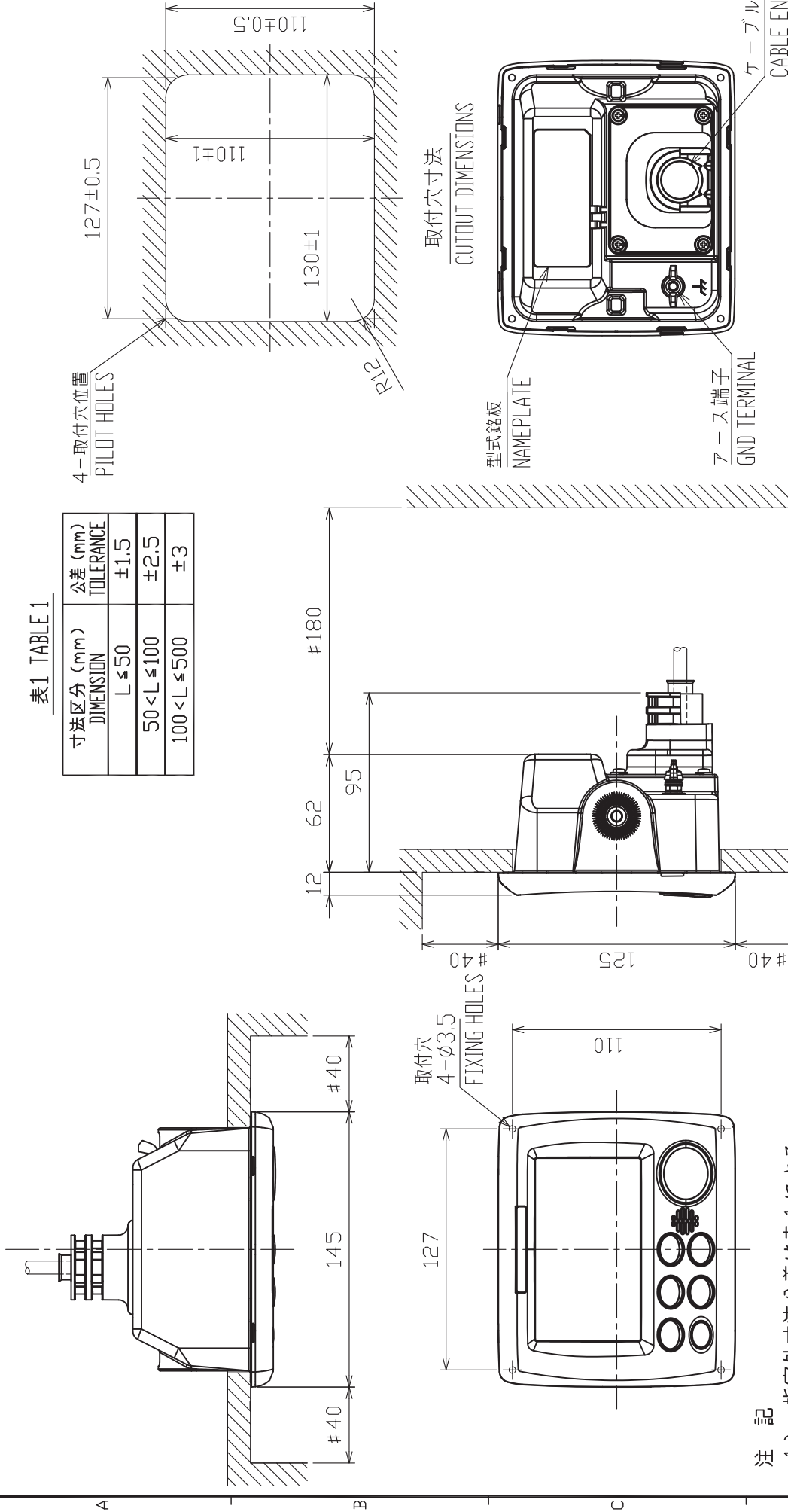
NOTE

1. TABLE 1 INDICATES TOLERANCE OF DIMENSIONS WHICH IS NOT SPECIFIED.
2. # MINIMUM SERVICE CLEARANCE.
3. USE PAN-HEAD TAPPING SCREWS φ3×20 FOR FIXING THE UNIT.

DRAWN	26/Dec/2017	I. YAMASAKI	TITLE	SC-702
CHECKED	26/Dec/2017	H. MAKI	名称	表示部 (埋込装備)
APPROVED	27/Dec/2017	H. MAKI	外寸図	
SCALE	1/3	質量 0.60 kg 質量はケーブルを含みません。 MASS DOES NOT INCLUDE CABLE.	NAME	DISPLAY UNIT (FLUSH MOUNT)
FIG. No.	C7282-602-B	REF. No.	20-037-201G-3	OUTLINE DRAWING



表1 TABLE 1

寸法区分 (mm) DIMENSION	公差 (mm) TOLERANCE
L ≤ 50	±1.5
50 < L ≤ 100	±2.5
100 < L ≤ 500	±3



取付穴
4-φ5
FIXING HOLES

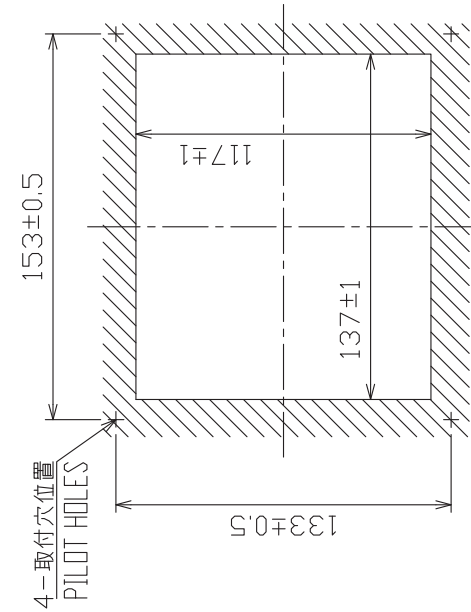
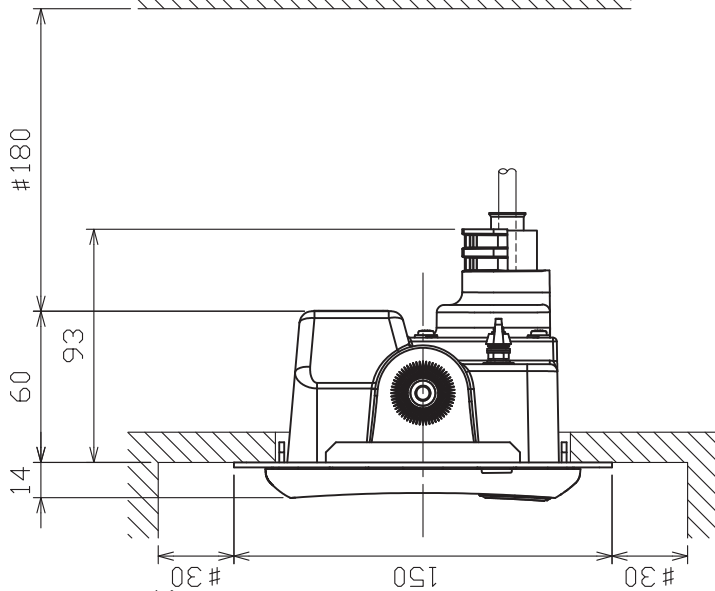
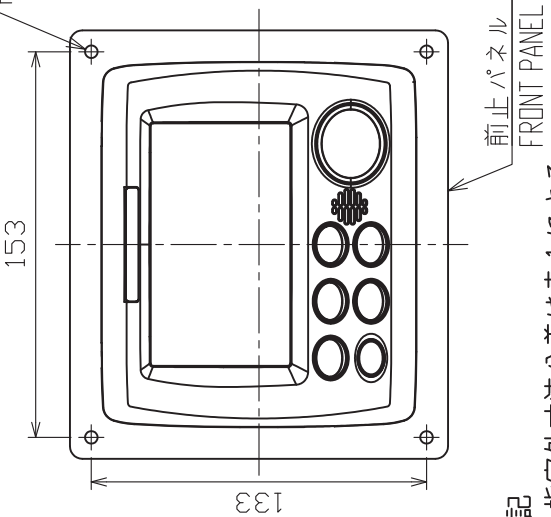

取付穴寸法図
CUTOUT DIMENSIONS

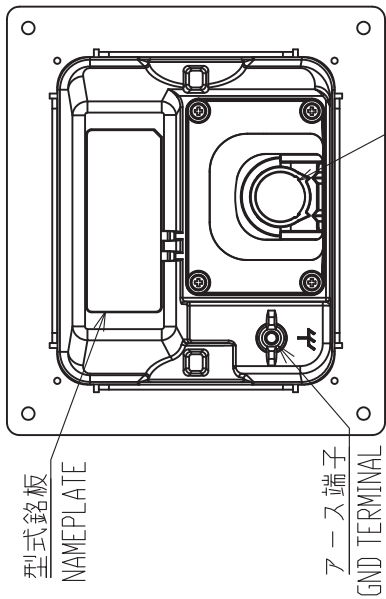

注 記

- 1) 指定外寸法公差は表 1 による。
- 2) # 印寸法は、最小サービス空間寸法とする。
- 3) 取付用ネジはトラススタッピネジ呼び径 4 × 1.6 を使用のこと。

NOTE

1. TABLE 1 INDICATES TOLERANCE OF DIMENSIONS WHICH IS NOT SPECIFIED.
2. # MINIMUM SERVICE CLEARANCE.
3. USE TAPPING SCREWS φ4x1.6 FOR FIXING THE UNIT.

DRAWN	26/Dec/2017	I. YAMASAKI	TITLE	SC-702
CHECKED	26/Dec/2017	H. MAKI	名称	表示部 (パネル装備)
APPROVED	27/Dec/2017	H. MAKI	外寸図	
SCALE	1/3	質量 0.65 kg 寸法 100%	NAME	DISPLAY UNIT (PANEL MOUNT)
IMG.No.	C7282-603-B	20-037-202G-3	OUTLINE DRAWING	

表1 TABLE 1

寸法区分 (mm) DIMENSION	公差 (mm) TOLERANCE
L ≤ 50	±1.5
50 < L ≤ 100	±2.5
100 < L ≤ 500	±3

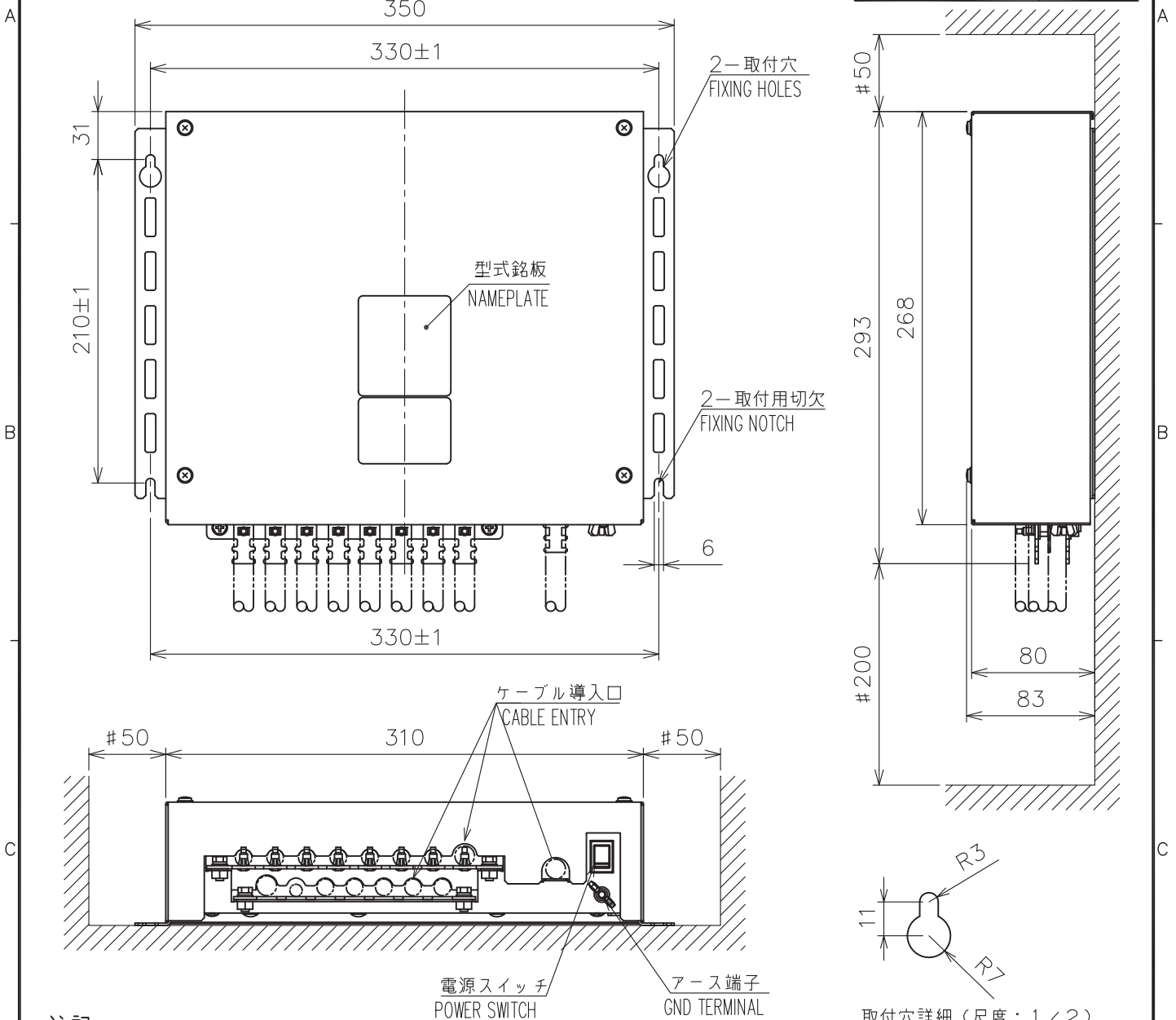

注記

- 1) 指定外の寸法公差は表1による。
- 2) #印寸法は最小サービス空間寸法とする。
- 3) 取付用ネジはタッピンネジM5×20、またはM5ボルトを使用のこと。

NOTE

1. TABLE 1 INDICATES TOLERANCE OF DIMENSIONS WHICH IS NOT SPECIFIED.
2. #: MINIMUM SERVICE CLEARANCE.
3. USE M5 BOLTS OR TAPPING SCREWS M5x20 FOR FIXING THE UNIT.

取付穴詳細 (尺度: 1/2)
DETAIL FOR FIXING (SCALE: 1/2)

表2 TABLE 2

変換基板 LAN-CNV	質量 (kg±10%) MASS
なし -	2.9
あり YES	3.1

DRAWN 17/Jan/2017 T.YAMASAKI	TITLE SC-701
CHECKED 17/Jan/2017 H.MAKI	名称 接続箱
APPROVED 17/Jan/2017 H.MAKI	外寸図
SCALE 1/4	NAME JUNCTION BOX
MASS表2参照 SEE TABLE 2	REF. No. 20-037-100G-3
DWG. No. C7282-G04-C	OUTLINE DRAWING



表1 TABLE 1

寸法区分 (mm) DIMENSION	公差 (mm) TOLERANCE
L ≤ 50	±1.5
50 < L ≤ 100	±2.5
100 < L ≤ 500	±3
500 < L ≤ 1000	±4

表2 TABLE 2

プラグ PLUG	交換基板 LAN-CONV	質量 MASS (kg±10%)
LAN	なし	2.8
TNC	あり	2.9

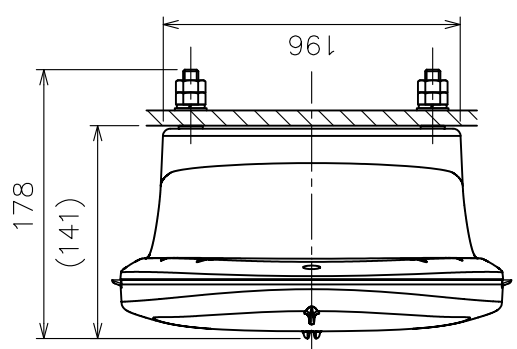

表1 TABLE 1



表1 TABLE 1

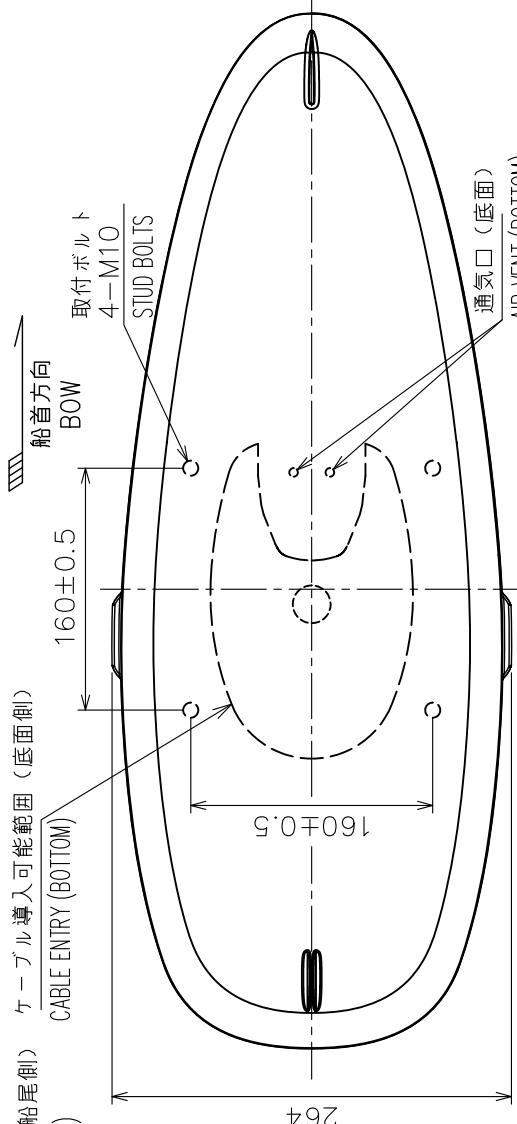

表1 TABLE 1

取付台例 (参考) (尺度: 1/1.0)
PLATFORM (EXAMPLE) (SCALE: 1/10)

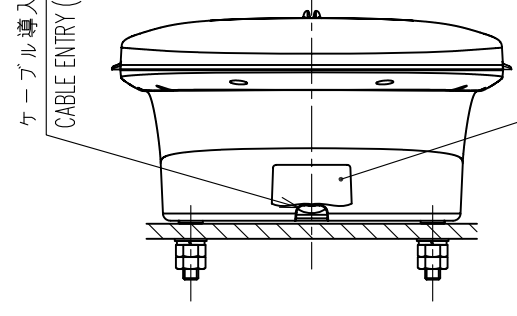
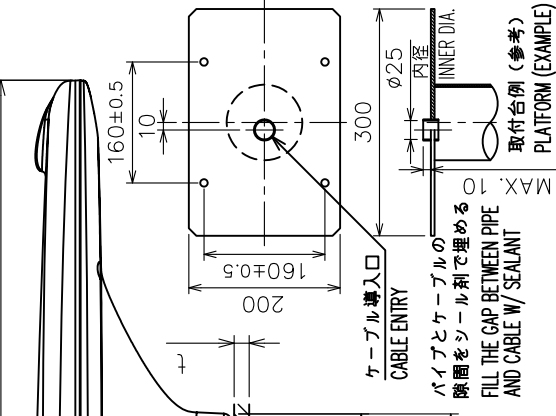
DRAWN	25/Feb/2021	I. YAMASAKI	TITLE	SC-703
CHECKED	25/Feb/2021	H. MAKI	各種	空中線部
APPROVED	26/Feb/2021	H. MAKI	外寸図	ANTENNA UNIT
SCALE	1/5	質量はケーブル(0.5m)を含む。 MASS INCLUDES 0.5m CABLE.	NAME	OUTLINE DRAWING
DWG.No.	C7282-G05-D	20-037-300G-3	REF.No.	

- 注記 1) 指定外の寸法公差は表1による。
2) 取付台の厚さ (t) は、5以上15以下とする。
- NOTE 1. TABLE 1 INDICATES TOLERANCE OF DIMENSIONS WHICH IS NOT SPECIFIED.
2. THICKNESS OF PLATFORM (t): 5 ≤ t ≤ 15.

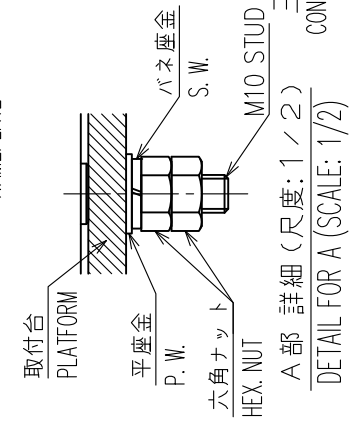

表1 TABLE 1

寸法区分 (mm) DIMENSION	公差 (mm) TOLERANCE
L ≤ 50	±1.5
50 < L ≤ 100	±2.5
100 < L ≤ 500	±3
500 < L ≤ 1000	±4
1000 < L ≤ 2000	±5

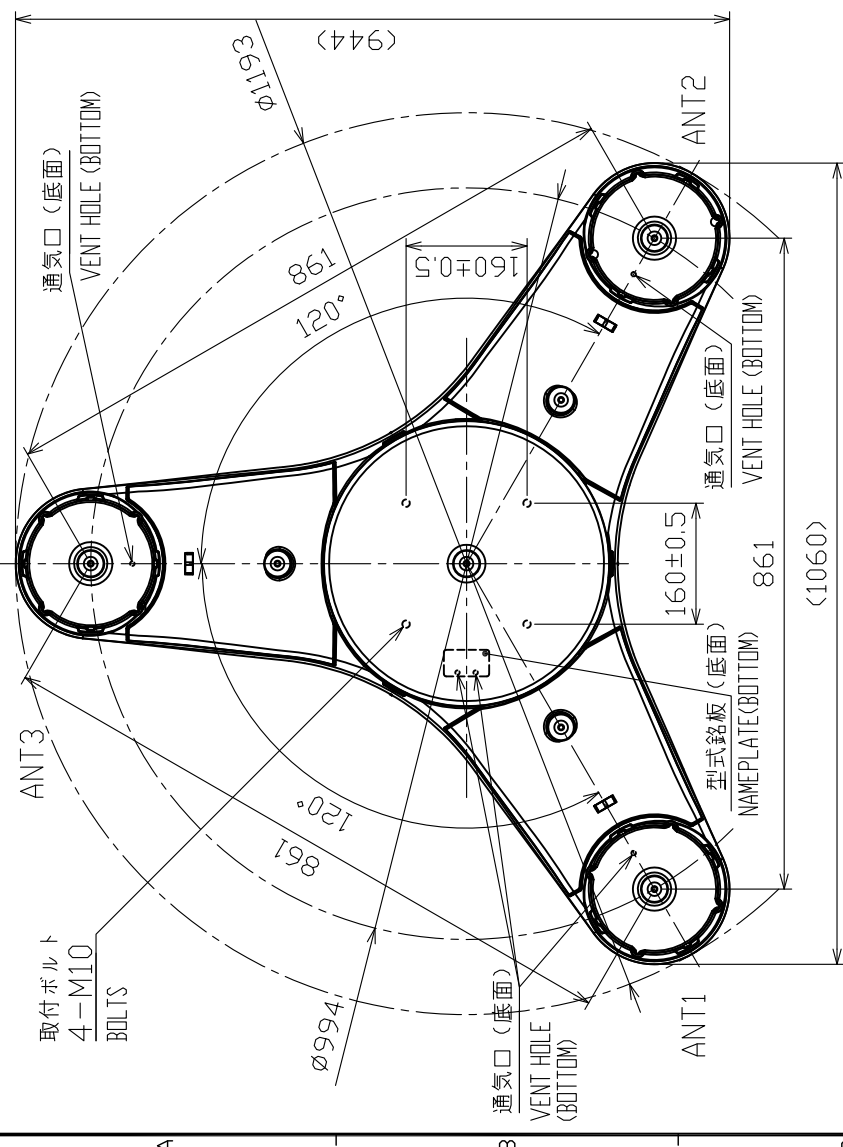
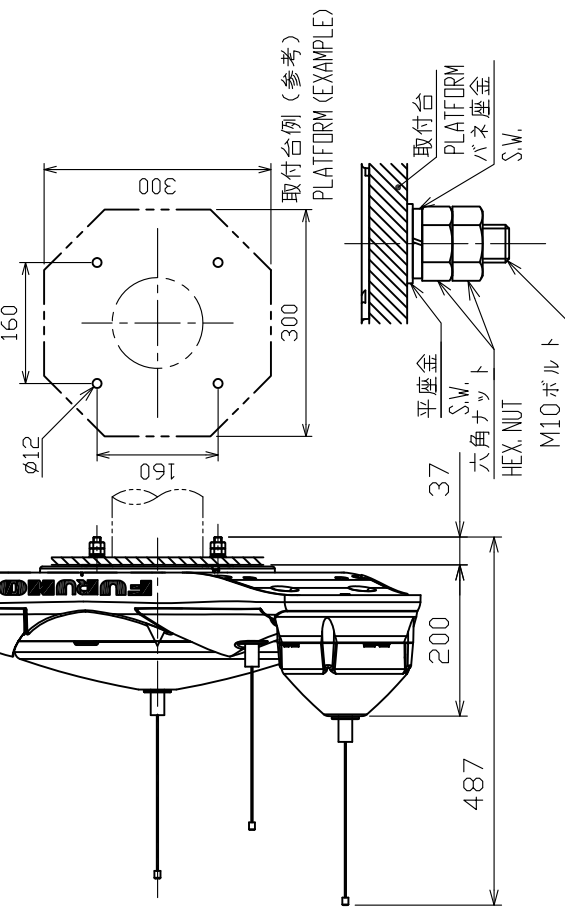

注 記 1) 指定外の寸法公差は表1による。
 2) 取付台の厚さ (t) は、5以上15以下とする。
 3) 取付面は平坦であること。

NOTE 1. TABLE 1 INDICATES TOLERANCE OF DIMENSIONS WHICH IS NOT SPECIFIED.
 2. THICKNESS OF PLATFORM (t): 5 ≤ t ≤ 15.
 3. PLATFORM SHOULD BE FLAT.

表2 TABLE 2

プラグ PLUG	交換基板 LAN-CONV	質量 MASS (kg±10%)
LAN	なし	7.1
TNC	あり	7.2

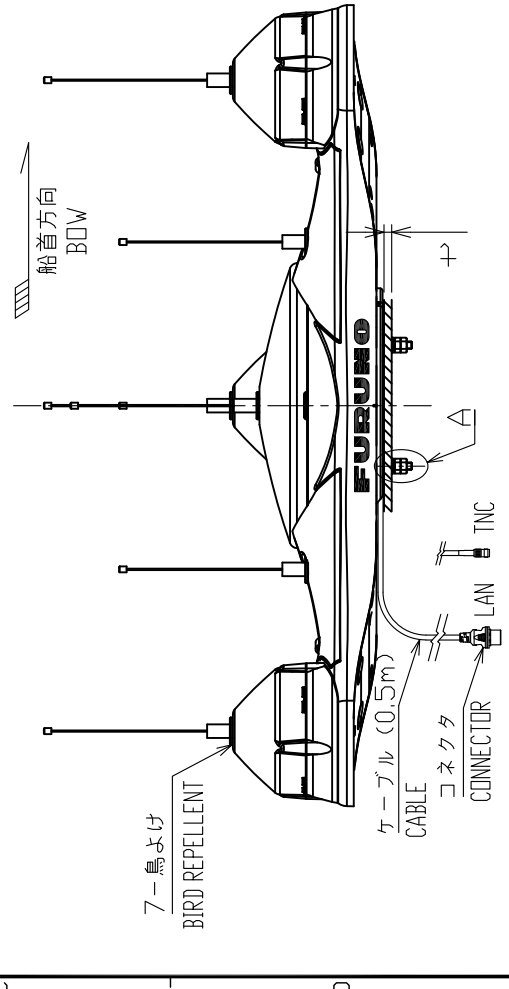

DRAWN	25/Feb/2021	I. YAMASAKI	TITLE	SC-1303
CHECKED	25/Feb/2021	H. MAKI	名称	空中線部
APPROVED	26/Feb/2021	H. MAKI	外寸図	
SCALE	1/10	表2	NAME	ANTENNA UNIT
FIG.No.	C7283-601-E	質量は座金・ナットを含まず MASS DOES NOT INCLUDE WASHER/UNIT.	REF.No.	20-037-350G-3
			OUTLINE DRAWING	

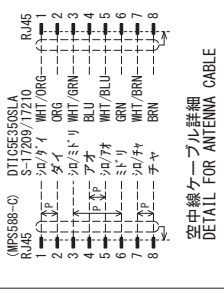
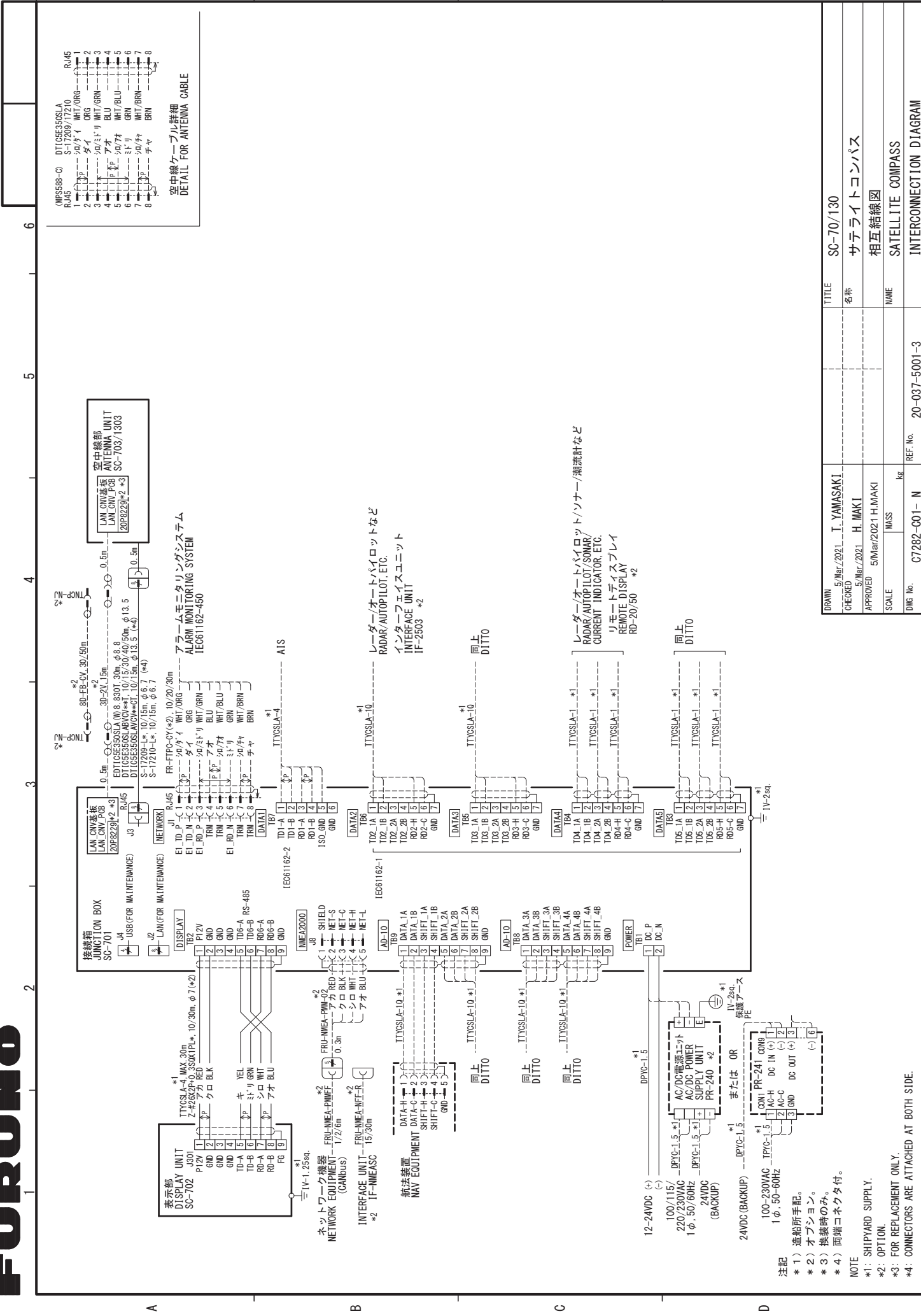

DRAWN	5/Mar./2021	I. YAMASAKI	TITLE	SC-70/130
CHECKED	5/Mar./2021	H. MAKI	名称	サテライトコンパス
APPROVED	5/Mar./2021	H. MAKI	相互結線図	相互結線図
SCALE	1/25	1/25	NAME	SATELLITE COMPASS
DWG No.	C7282-001-N	REF. No.	20-037-5001-3	INTERCONNECTION DIAGRAM

- 注記
- *1) 造船所手配。
 - *2) オプション。
 - *3) 換装時のみ。
 - *4) 同端コネクタ付。
- NOTE
- *1: SHIPYARD SUPPLY.
 - *2: OPTION.
 - *3: FOR REPLACEMENT ONLY.
 - *4: CONNECTORS ARE ATTACHED AT BOTH SIDE.

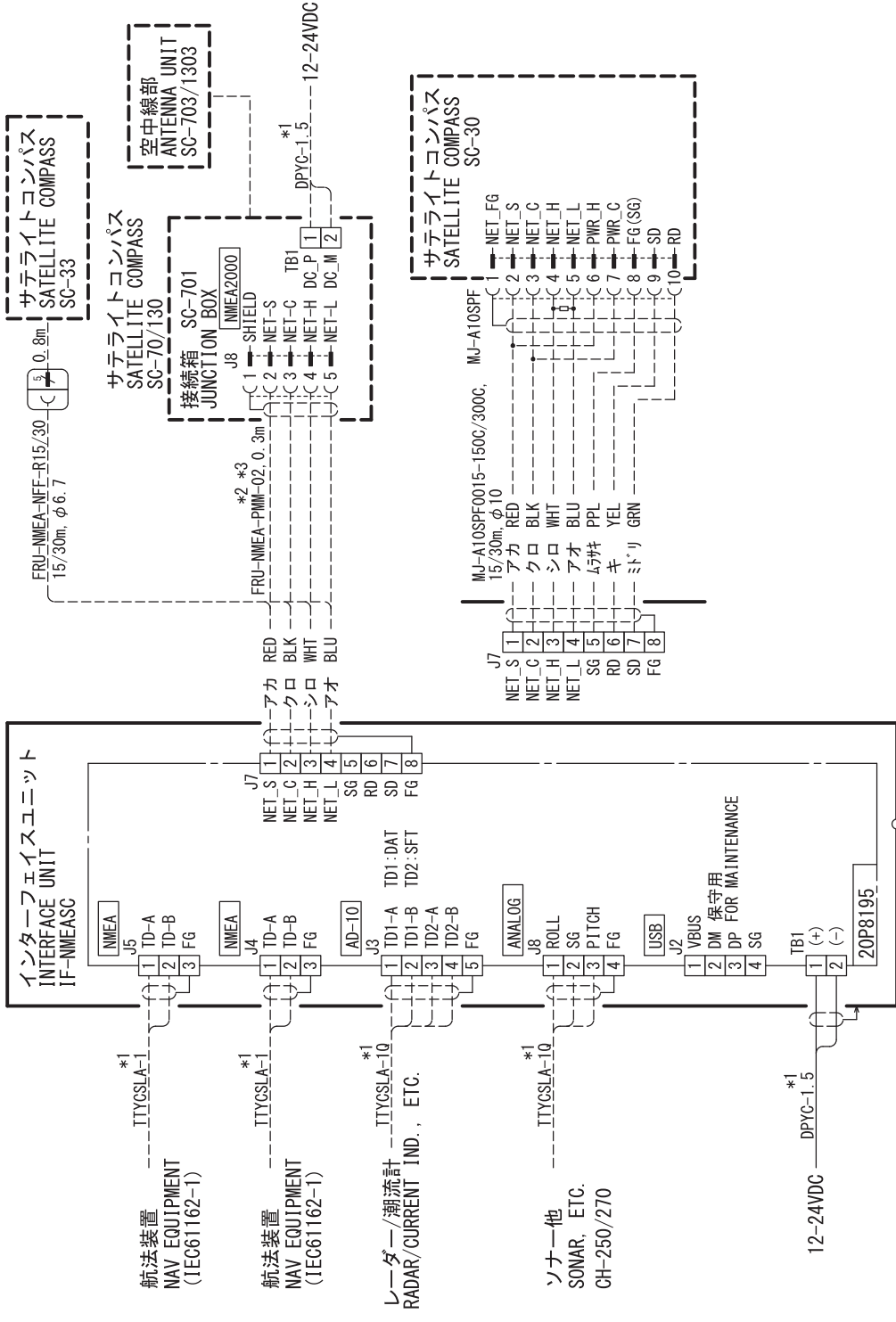

- 注記**
- * 1) 造船所手配。
 - * 2) オプション。
 - * 3) コネクタを取り外して接続する。
- NOTE**
- *1: SHIPYARD SUPPLY.
 - *2: OPTION.
 - *3: REMOVE THE PLUG FOR FABRICATION.

DRAWN	18/JAN/2021	T. YAMASAKI	TITLE	IF-NMEASC
CHECKED	18/JAN/2021	H. MAKI	名称	インターフェイスユニット
APPROVED	27/JAN/2021	H. MAKI	相互結線図	
SCALE	MASS	kg	NAME	INTERFACE UNIT
DWG. No.	C7265-C02-C		REF. No.	INTERCONNECTION DIAGRAM

INDEX

- A**
- Alerts2-16
 - acknowledge2-18
 - alert codes.....AP-4
 - alert list.....AP-4
 - buzzer on/off2-19
 - definition.....2-16
 - list.....2-19
 - log2-21
- B**
- Background color2-25
- Backup user settings.....4-3
- Basic troubleshooting.....4-2
- C**
- Controls.....2-1
- D**
- Data schematicsAP-14
- Data sentencesAP-13
- Data transmissionAP-13
- Date2-27
- DGPS/SBAS settings2-30
- Diagnostics4-5
 - automatic test.....4-7
 - keyboard test.....4-6
 - LCD test4-6
 - memory test4-5
 - sound test.....4-7
- Display
 - change mode2-5
 - GPS mode.....2-7
 - icons.....2-6
 - indications2-6
 - navigational data.....2-16
 - ROTI mode.....2-14
 - SPD mode.....2-15
 - THD mode.....2-10
- Display overview2-5
- E**
- EGNOSAP-12
- F**
- Fuse4-1
- G**
- GAGANAP-12
- Geodetic chart codesAP-11
- Geodetic data settings2-27
- GNSS settings2-29
- I**
- I/O settings
 - data logs.....2-35
 - data sources.....2-34
 - HDG output restart.....2-37
 - LAN data output2-33
 - serial data output.....2-32
- Initial Settings
 - offsets.....1-28
 - OS dimensions1-26
- Input sentences.....AP-14
- Installation
 - display unit - bulkhead1-8
 - display unit - desktop1-8
 - display unit - flushmount1-9
 - optional waterproofing kit1-22
 - RD-50 remote display unit.....1-10
 - SC-1303 antenna unit1-5
 - SC-701 junction box.....1-7
 - SC-702 display unit.....1-8
 - SC-703 antenna unit1-3
 - waterproofing connections1-14
- Installation considerations
 - SC-701 junction box.....1-7
 - SC-702 display unit.....1-8
 - SC-703/SC-1303 antenna units1-1
- J**
- JIS cable guideAP-28
- L**
- Language2-28
- M**
- Maintenance4-1
 - fuse4-1
- Menu tree.....AP-1
- MSASAP-12
- N**
- NMEA2000.....3-1
 - Input3-1
 - Output3-1
- O**
- Output sentencesAP-16
- R**
- RAIM
 - setup2-31
- S**
- SBAS providers.....AP-12
- SBAS search.....2-30
- Smoothing2-26
- T**
- Time2-27
- Transmission intervalsAP-13
- Trip meter.....2-27

U

Units of measurement 2-25

User settings

backup..... 4-3

W

WAAS.....AP-12

Wiring 1-11

cable fabrication 1-12

display unit 1-20

junction box 1-17



0575

Declaration of Conformity



0097

We FURUNO ELECTRIC CO., LTD.

(Manufacturer)

9-52 Ashihara-Cho, Nishinomiya City, 662-8580, Hyogo, Japan

(Address)

declare under our sole responsibility that the product

SATELLITE COMPASS SC-70 and SC-130

(Serial No. 1000-56xx/88xx-xxxx)

(Model name, type number)

to which this declaration relates conforms to the following standard(s) or other normative document(s)

EU

Directive 2014/90/EU on Marine Equipment (MED) as amended the Implementing Regulation (EU) 2025/1533

SOLAS 74 Reg. V/18, V/19 & X/3
IMO Res. A.526(13), A.694(17), MSC.36(63),
MSC.97(73), MSC.112(73), MSC.116(73),
MSC.191(79), MSC.302(87)

(title and number of the requirements)

UK

UK MCA Merchant Shipping (Marine Equipment) Regulations 2025 (MER) as amended MSN 1874 Amendment 11

SOLAS 74 Reg. V/18, V/19 & X/3
IMO Res. A.526(13), A.694(17), MSC.36(63),
MSC.97(73), MSC.112(73), MSC.116(73),
MSC.191(79), MSC.302(87)

For assessment, see

- EC-type examination certificate (Module B)
MEDB00001BW Rev.4 (GNSS),
MEDB00001BX Rev.4 (ROTI),
MEDB00001BY Rev.5 (THD); DNV AS (0575)
- Product Quality System certificate (Module D)
MEDD00002CD Rev.10; DNV AS (0575)
- UK-type examination certificate (Module B)
MERB00001BW Rev.3 (GNSS),
MERB00001BX Rev.3 (ROTI),
MERB00001BY Rev.4 (THD); DNV UK Ltd. (0097)
- Product Quality System certificate (Module D)
MERD00002CD Rev.8; DNV UK Ltd. (0097)

On behalf of Furuno Electric Co., Ltd.

Nishinomiya City, Japan
9 February 2026

Akihiko Kanechika
Department General Manager
Quality Assurance Department

(Place and date of issue)

(name and signature or equivalent marking of authorized person)

PSTI Statement of Compliance

We FURUNO ELECTRIC CO., LTD.

(Name of manufacturer of the product)

9-52 Ashihara-Cho, Nishinomiya City, 662-8580, Hyogo, Japan

(Address of manufacturer of the product)

declare under our sole responsibility that the product

SATELLITE COMPASS

SC-70, SC-130

(Product type, batch)

February / 28 / 2027

(Support period for the product)

https://www.furuno.co.jp/en/cs/sociality/customer/product_security.html

(Weblink for latest information and contact to report to the manufacturer security issues)

to which this declaration relates conforms to the following standard(s) or other normative document(s)

Product Security and Telecommunications Infrastructure Act 2022

Product Security and Telecommunications Infrastructure (Security Requirements for Relevant Connectable Products) Regulations 2023 Schedule 1

On behalf of Furuno Electric Co., Ltd.

Nishinomiya City, Japan
28 June 2024

Akihiko Kanechika
Department General Manager
Quality Assurance Department

(Place and date of issue)

(Signature, name and function of the signatory)