

COBHAM

SAILOR 6081 Power Supply Unit and Charger

Installation manual



SAILOR 6081 Power Supply Unit and Charger

Installation manual

Document number: 98-130980-E

Release date: October 25, 2019

Disclaimer

Any responsibility or liability for loss or damage in connection with the use of this product and the accompanying documentation is disclaimed by Thrane & Thrane A/S. The information in this manual is provided for information purposes only, is subject to change without notice and may contain errors or inaccuracies. Manuals issued by Thrane & Thrane A/S are periodically revised and updated. Anyone relying on this information should acquire the most current version e.g. from www.cobham.com/satcom, **Cobham SYNC Partner Portal**, or from the distributor. Thrane & Thrane A/S is not responsible for the content or accuracy of any translations or reproductions, in whole or in part, of this manual from any other source. In the event of any discrepancies, the English version shall be the governing text.

Thrane & Thrane A/S is trading as Cobham SATCOM.

Copyright

© 2019 Thrane & Thrane A/S. All rights reserved.

Manufacturer address

Thrane & Thrane A/S, Lundtoftegaardsvej 93 D, DK-2800, Kgs. Lyngby, Denmark.

Disposal

Old electrical and electronic equipment marked with this symbol can contain substances hazardous to human beings and the environment. Never dispose these items together with unsorted municipal waste (household waste). In order to protect the environment and ensure the correct recycling of old equipment as well as the re-utilization of individual components, use either public collection or private collection by the local distributor of old electrical and electronic equipment marked with this symbol.



Contact the local distributor for information about what type of return system to use.

Safety summary

The following general safety precautions must be observed during all phases of operation, service and repair of this equipment. Failure to comply with these precautions or with specific warnings elsewhere in this manual violates safety standards of design, manufacture and intended use of the equipment. Thrane & Thrane A/S assumes no liability for the customer's failure to comply with these requirements.

GROUND THE EQUIPMENT

To minimise shock hazard, the equipment chassis and cabinet must be connected to an electrical ground and the cable instructions must be followed.

DO NOT OPERATE IN AN EXPLOSIVE ATMOSPHERE

Do not operate the equipment in the presence of flammable gases or fumes. Operation of any electrical equipment in such an environment constitutes a definite safety hazard.

KEEP AWAY FROM LIVE CIRCUITS

Operating personnel must not remove equipment covers. Component replacement and internal adjustment must be made by qualified maintenance personnel. Do not service the unit with the power cable connected. Always disconnect and discharge circuits before touching them.

OBSERVE MARKED AREAS

Under extreme heat conditions do not touch areas of the unit that are marked with this symbol, as it may result in injury.



COMPASS SAFE DISTANCE

Minimum safety distance: 30 cm from the unit.



Warning! Never insert or remove a power supply while its power switch is in the On (I) position. Make sure the power switch is Off (O) first.

Failure to comply with the rules above will void the warranty!

About the manual

Intended readers

This manual is an installation manual for the SAILOR 6081 Power Supply Unit and Charger. It is important that you observe all safety requirements listed in the beginning of this manual, and operate the SAILOR 6081 Power Supply Unit and Charger according to the instructions and guidelines in this manual. All installation must be done by qualified service personnel.

Manual overview

This manual has the following chapters:

- **Introduction** contains a description of the principle of operation and uses and features of the power supply.
- **Installation** contains step-by-step guidelines how to install the power supply as a stand-alone unit or in a combined setup and describes the connectors.
- **Service and repair** contains information on support, how to return units for repair and instructions how to exchange the fuses.
- Appendices with **Technical specifications** and **Upgrade instructions**.

Typography

In this manual, typography is used as indicated below:

Bold is used to emphasize words and to indicate connector names of the unit.

Italic is used to emphasize the paragraph title in cross-references.

Related documents

SAILOR 6080 Power Supply, Installation manual (98-129099).

Table of contents

Chapter 1	Introduction	
	1.1 General description	1
	1.2 Features.....	3
	1.3 System configuration – examples.....	4
Chapter 2	Installation	
	2.1 Unpacking.....	5
	2.2 Installing the SAILOR 6081.....	6
Chapter 3	Service and repair	
	3.1 Support, repair and service.....	25
	3.2 Alert messages.....	27
	3.3 Exchanging the fuses	29
	3.4 Returning units for repair	31
Chapter 4	Customizing battery settings	
	4.1 Battery settings.....	33
	4.2 Changing the battery settings.....	34
Appendix A	Technical specifications	
	A.1 SAILOR 6081 Power Supply Unit and Charger	37
	A.2 SAILOR 6080 Power Supply	39
Appendix B	Upgrade	
	B.1 Overview.....	41
	B.2 Upgrading with additional SAILOR 6080 units.....	47

Appendix C Approvals

C.1 IEC 60945 53
C.2 Wheelmark..... 53

Glossary 55

Index 57

Introduction

1.1 General description

The SAILOR 6081 Power Supply Unit and Charger provides DC power at five DC power outlets (all separately fused) and a 15 V DC power outlet, e.g. for CAN interface. It also charges a connected battery automatically. If the AC power fails the SAILOR 6081 provides uninterrupted switch over to DC power from battery to the connected equipment.

You can access control and monitoring data via the Ethernet interface. The SAILOR 6081 provides dry contact alarm output for AC failure as well as alarm for DC high and low voltage on the battery.

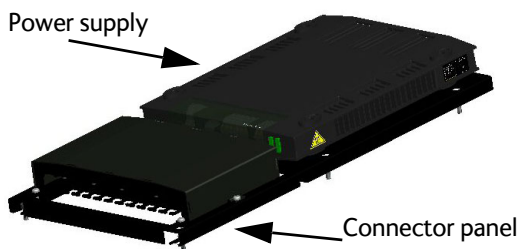

The power supply provides up to 1480 W peak in total. The following models are available:

Model	Peak output power
SAILOR 6081	Max. 370 W
SAILOR 6081 with 1 additional SAILOR 6080	Max. 740 W
SAILOR 6081 with 2 additional SAILOR 6080	Max. 1110 W
SAILOR 6081 with 3 additional SAILOR 6080	Max. 1480 W

Depending on the output power needed, the SAILOR 6081 Power Supply Unit and Charger includes up to four SAILOR 6080 units and one connector

panel. The SAILOR 6081 can be upgraded on site to more output power by adding up to three SAILOR 6080 units. The connectors for DC power are placed at the same end of the unit for easy mounting and installation. The connection between the SAILOR 6081 Power Supply Unit and Charger unit(s) and the connector panel is protected by a cover. A cable relief bracket to secure heavy cables is integrated in the wall-mount tray.

1.1.0.1 SAILOR 6080

The SAILOR 6080 Power Supply can deliver 300 W output power on average with a peak of 370 W for max. 2 minutes (10% duty cycle). The SAILOR 6081 Power Supply Unit and Charger is AC powered and has an on/off switch which is lit when the power is turned on.



1.1.1 Battery charger

In case of AC power failure or overload a battery connected to the SAILOR 6081 Power Supply Unit and Charger delivers the required power seamlessly. Note that output power has a higher priority than the charging current.

To charge deeply discharged batteries (battery voltage lower than 23 V) the SAILOR 6081 Power Supply Unit and Charger has a pre-charge mode. Regular charging starts as soon as the battery voltage is above 23 V. The maximum charging current and the nominal battery voltage can be adjusted. For further details see *Customizing battery settings* on page 33.

Note

If the charging voltage of the battery terminal is below 8 V the charging process will not start.

1.2 Features

The SAILOR 6081 Power Supply Unit and Charger has the following features:

- Output voltage according to battery requirements (range: 24 — 31.2 V)
- 15 VDC output for SAILOR 3027 Terminal
- DC connectors, 2 x 10 A, 2 x 20 A and 1 x 50 A
- Up to 1480 W peak output power (max. 2 min., 10% duty cycle)
- AC input (100-240 VAC nominal) with fuse (6.3 A) with Power Factor Correction
- Automatic detection of input voltage range
- AC alarm and battery voltage alarm
- Ethernet connector for monitoring and control information
- Battery charging function
- Short circuit protection
- Over-temperature protection (shutdown with automatic restart)
- Switch over to battery power in case of AC supply failure
- Link to control up to 8 SAILOR 6081 Power Supply Unit and Charger units connected to the same battery
- Upgrade on site by service personnel
- IP 30 protection
- Approval and certification: IEC 60945 and Wheelmark approval

1.3 System configuration – examples

The SAILOR 6081 Power Supply Unit and Charger is designed to be used in installations that need a stable and powerful power supply with battery charger. The drawing below shows a setup in which the SAILOR 6081 Power Supply Unit and Charger generates the DC supply in a GMDSS system.

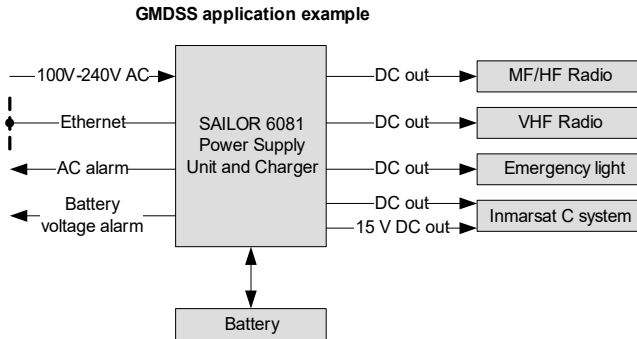

The drawing below shows an example how this power supply fits into an installation with two segments, which is a GMDSS requirement. Each segment has its own power supply, but often the two segments share the battery.

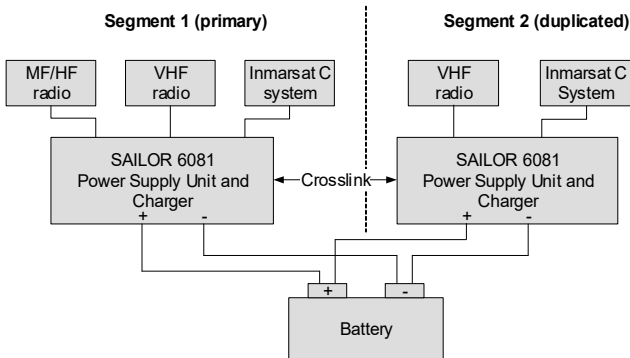

Installation

This chapter provides information about

- *Unpacking*
- *Installing the SAILOR 6081*

2.1 Unpacking

The following items are included in the delivery:

- SAILOR 6081 Power Supply Unit and Charger
- SAILOR 6081 Power Supply Unit and Charger Installation manual (this manual)
- Installation kit for adding up to 2 SAILOR 6080 units

For SAILOR 6081 Power Supply Unit and Charger with 3 additional SAILOR 6080 units you must order the following option:

- Installation kit, for mounting 3 additional SAILOR 6080 (Part number S-406081-004)

2.2 Installing the SAILOR 6081

You can mount the power supply in a vertical or horizontal position. Vertical mounting is recommended if more than 2 units are stacked.



Warning! Never insert or remove a power supply while its power switch is in the On (I) position. Make sure the power switch is Off (O) first.

2.2.1 Temperature conditions

The SAILOR 6081 must be placed in a ventilated area with free space around all sides of the unit, except the bottom side.

Ambient temperature range is -15°C to $+55^{\circ}\text{C}$.

If the SAILOR 6081 is installed in a location where the ambient temperature may exceed 45°C , we recommend placing the SAILOR 6081 where unintentional contact is avoided. If the maximum ambient temperature does not exceed 45°C , the SAILOR 6081 can be placed in a public area.

The SAILOR 6081 Power Supply Unit and Charger can be mounted as a single unit. If you need more power than a SAILOR 6081 Power Supply Unit and Charger can deliver, upgrade by adding up to 3 SAILOR 6080 units. For details see *Upgrade* on page 41.

2.2.2 Outline and dimensions

The following drawing shows the wall-mount tray of the SAILOR 6081 Power Supply Unit and Charger and the SAILOR 6080.

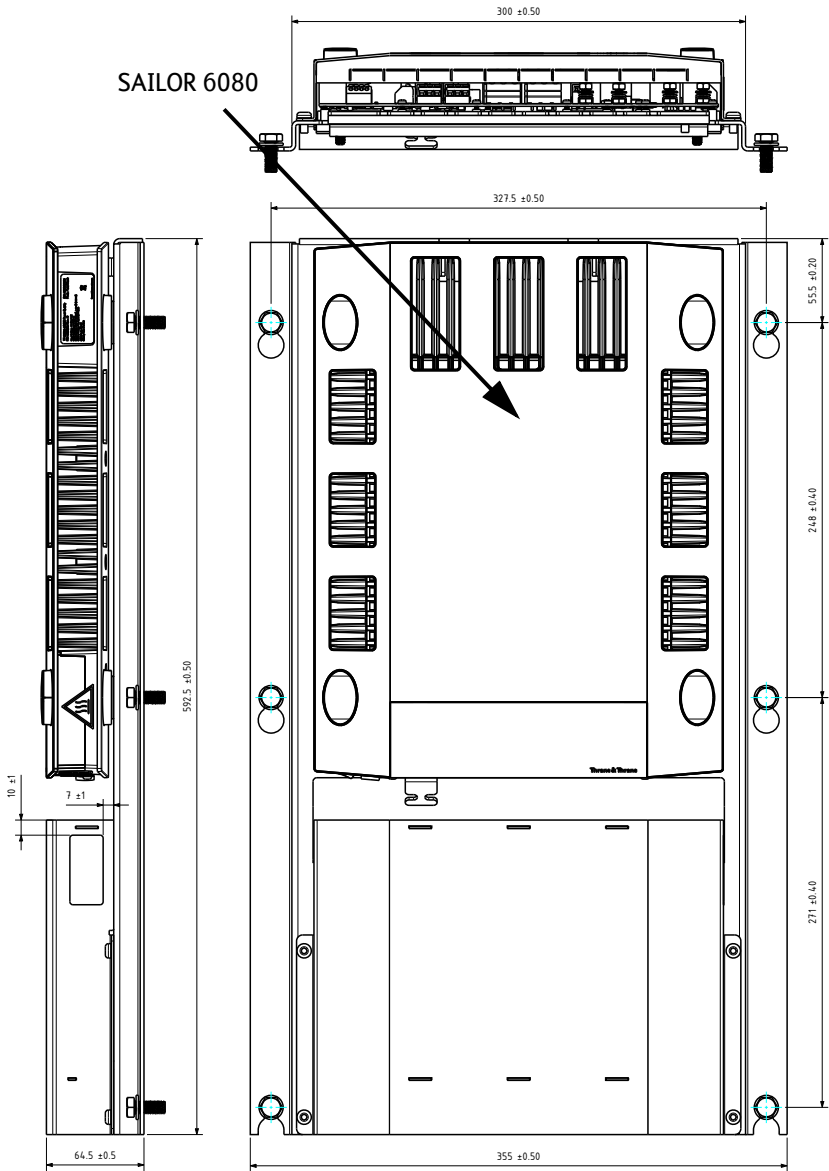

2.2.3 Connectors

2.2.3.1 Connector overview — example

The following image shows a connector panel of a SAILOR 6081 with 2 additional SAILOR 6080.

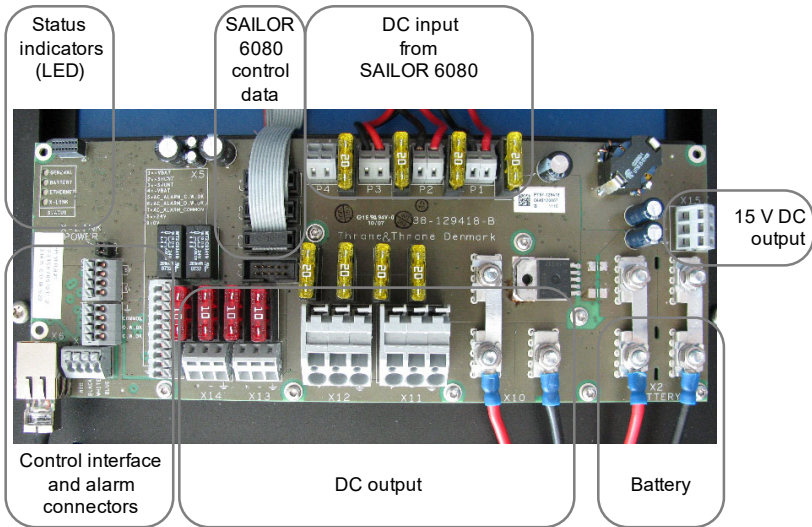

2.2.3.2 Connectors on the SAILOR 6081

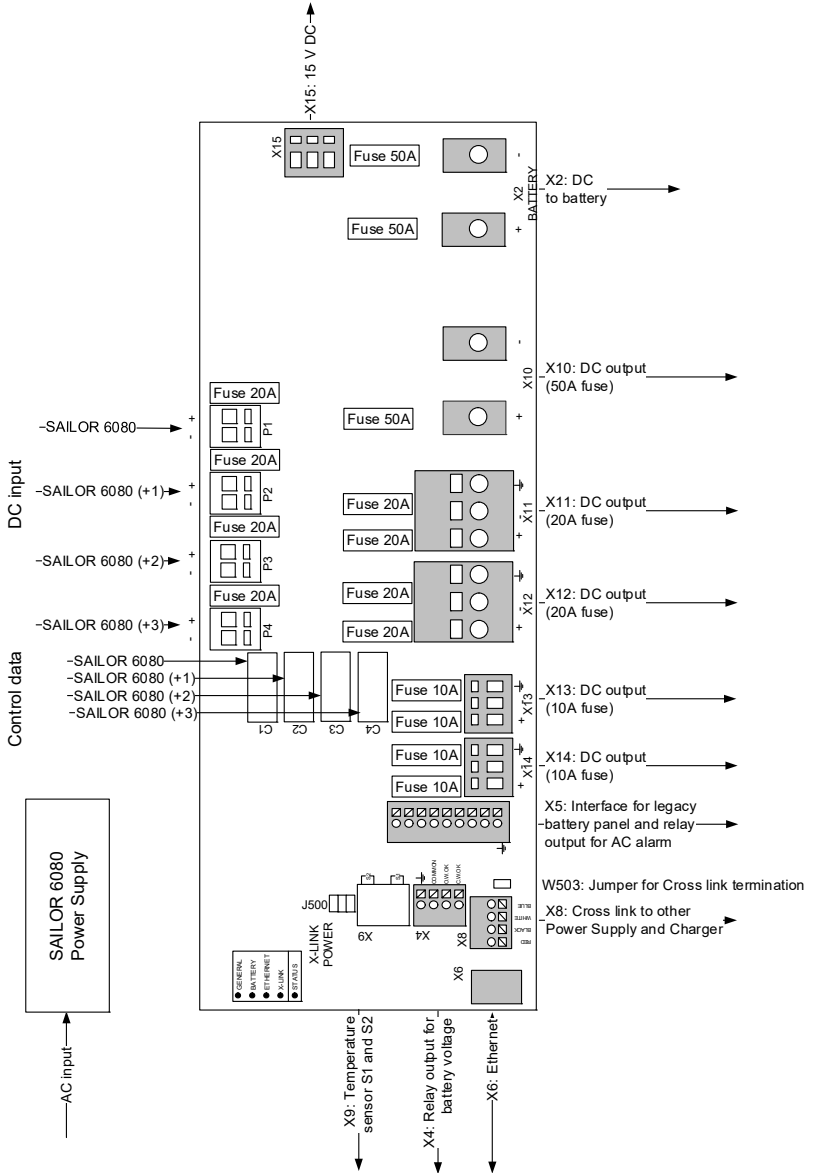

Installation

2.2.3.3 Grounding

1. Connect chassis to ship with a cable (minimum wire cross section: 4 mm²) or equivalent. The maximum cable length is 1 m.
2. Connect the drain wire for each cable to the designated GND terminal or bolt it to the mounting plate as shown below (2).

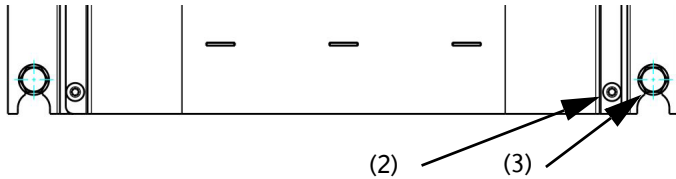

3. Ground the SAILOR 6081 Power Supply Unit and Charger to ship, for example at the screw holding the mounting plate, as shown above (3).

2.2.4 Connectors and jumpers

- AC input (on SAILOR 6080)
- DC output (50 A) (X10)
- 2 x DC output (20 A) (X11 and X12)
- 2 x DC output (10 A) (X13 and X14)
- 15 V DC output (3 A) (X15)
- Battery connector (X2)
- Battery temperature sensor S1 (X9)
- Ethernet interface for monitoring and control (X6)
- Interface for legacy battery panel and relay output for AC alarm (X5)
- Relay output for battery voltage alarm (X4)
- C1, C2, C3 and C4 for Control data
- P1, P2, P3 and P4 for DC input from SAILOR 6080
- Crosslink interface (X8) when sharing a battery
- Jumper J500 for crosslink interface (X-LINK POWER)
- Jumper W503 for termination of crosslink

2.2.4.1 AC input (on SAILOR 6080)

The SAILOR 6080 Power Supply is AC powered. To connect the AC input do as follows:

1. Remove the u-shaped cut-out for this input from the protective lid.
2. Connect the Mains cable to the connector marked **MAINS AC**.

Mains AC (on SAILOR 6080)	
Connector type	Spring loaded terminal, dual-row connector
Wire cross section	Up to 2.5 mm ² (AWG 13)
L	Line. AC power cord
N	Neutral. AC power cord
	GND. AC power cord
Fuse	6.3 A. It is accessible from outside the housing. It is positioned next to the on/off switch. To remove the fuse turn the device that holds the fuse and extract it.

This connector is used when adding a SAILOR 6080 Power Supply (dual row spring loaded terminal).

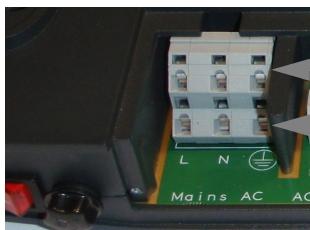

To connect to additional
AC/DC Power Supply

AC input

2.2.4.2 DC output (50 A) (X10)

DC output (X10)	
Connector type	Cable lug bolted to the board.
+	DC output plus
-	DC output minus
M5 in chassis	GND for drain wire (cable shield)
Fuse	One 50 A fuse plate for DC output plus. You must use the fuse with the part number S-33-205377-050.

2.2.4.3 2 x DC output (20 A) (X11 and X12)

DC output (X11 and X12)	
Connector type	Spring loaded terminal
Wire cross section	Up to 6 mm ² (AWG 9)
+	DC output plus
-	DC output minus
M5 in chassis	GND for drain wire (cable shield)
	GND for safety wire
Fuses	Two 20 A fuses, one for DC output plus and one for DC output minus. ^a

a. This output is rated up to 30 A, thus 30 A fuses may be used.

2.2.4.4 2 x DC output (10 A) (X13 and X14)

DC output (X13 and X14)	
Connector type	Spring loaded terminal
Wire cross section	Up to 2.5 mm ² (AWG 13)
+	DC output plus
-	DC output minus
M5 in chassis	GND for drain wire (cable shield)
	GND for safety wire
Fuses	Two 10 A fuses, for DC output plus and one for the DC output minus.

2.2.4.5 15 V DC output (3 A) (X15)

15 V DC output (X15)	
Connector type	Spring loaded terminal
Wire cross section	Up to 2.5 mm ² (AWG 13)
+	15 V DC output plus
-	15 V DC output minus
M5 in chassis	GND for drain wire (cable shield)
	GND for safety wire

2.2.4.6 Battery connector (X2)

The SAILOR 6081 Power Supply Unit and Charger can charge a connected battery.

BATTERY (X2)	
Connector type	Cable lug bolted to the board
Screw size	5 mm
+	Battery plus
-	Battery minus
M5 in chassis	GND for drain wire (cable shield)
Fuses	One 50 A fuse plate for battery plus and one for the battery minus. You must use the fuse with the part number S-33-205377-050.

In case of overload and/or missing AC power the power supply seamlessly delivers power from the connected battery.

The default maximum charging current is 8 A. The default float voltage is 27.2 V at 20° C. These values depend on the battery specification. Check the documentation for the battery.

The maximum charging current and the float voltage can be configured, for further details see *Customizing battery settings* on page 33.

2.2.4.7 Battery temperature sensor S1 (X9)

In order to optimize the battery charging profile, a temperature sensor may be mounted on the battery and connected to X9-S1. It is part of the delivery and available as an option. You can order it (part number: 406081-010).

Note | One battery temperature sensor serves all cross-linked units.

2.2.4.8 Ethernet interface for monitoring and control (X6)

There is one Ethernet (10/100 MB) connector on the connector panel. Monitoring and control data are available at this interface.

Ethernet (X6)		Wire color
Connector type	RJ-45, female	
Pin 1	Tx+	white/orange
Pin 2	Tx-	orange
Pin3	Rx+	white/green
Pin 4	Not connected	blue
Pin 5	Not connected	white/blue
Pin 6	Rx-	green
Pin 7	Not connected	white/brown
Pin 8	Not connected	brown

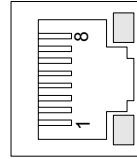

2.2.4.9 Interface for legacy battery panel and relay output for AC alarm (X5)

Attach the cable to the connector marked **X5** according to the specifications in the table below:

AC ALARM (X5)	
Connector type	Spring loaded terminal
Wire cross section	Up to 0.75 mm ² (AWG 18)
Terminal 1	VBAT

AC ALARM (X5)	
Terminal 2	+ SHUNT
Terminal 3	- SHUNT
Terminal 4	- VBAT
Terminal 5	Closed when OK (AC alarm)
Terminal 6	Open when OK (AC alarm)
Terminal 7	Common (AC alarm)
Terminal 8	24 V
Terminal 9	0 V
	GND for drain wire (cable shield)

The current shown in the connected battery panel is the sum of all currents to or from the battery.

Example: 2 SAILOR 6081 Power Supply Unit and Charger units share one battery, each unit charges with 4 A. The sum of all charging currents shown in the battery panel will be 8 A.

Example: 2 SAILOR 6081 Power Supply Unit and Charger units share one battery, one unit **charges** with 4 A, the other unit **draws** 3 A. The sum of all charging currents shown in the battery panel will be 1 A (4 A minus 3 A).

2.2.4.10 Relay output for battery voltage alarm (X4)

An alarm is generated if the battery voltage is outside the allowed voltage range.

- Default voltage for battery alarm, lower limit: 23.5 V
- Default voltage for battery alarm, upper limit: 29.5 V

These limits can be changed. For further details see *Customizing battery settings* on page 33. Connect the cable to the connector marked **X4** according to the specifications in the table below:

Battery Alarm (X4)	
Connector type	Spring loaded terminal
Wire cross section	Up to 0.75 mm ² (AWG 18)
Terminal 1	Closed when ok
Terminal 2	Open when ok
Terminal 3	Common
Terminal 4 	GND for drain wire (cable shield)

2.2.4.11 C1, C2, C3 and C4 for Control data

These connectors are used for control data from the installed SAILOR 6080 units to the SAILOR 6081 Power Supply Unit and Charger.

Connecting SAILOR 6080 units	Connector
SAILOR 6081	C1
SAILOR 6081 + 1 SAILOR 6080	C1 + C2
SAILOR 6081 + 2 SAILOR 6080	C1 + C2 + C3
SAILOR 6081 + 3 SAILOR 6080	C1 + C2 + C3 + C4

For instructions how to connect control data from an additional SAILOR 6080 when upgrading, see *Upgrading with additional SAILOR 6080 units* on page 47.

2.2.4.12 P1, P2, P3 and P4 for DC input from SAILOR 6080

These connectors are used for DC input from the installed SAILOR 6080 units to the SAILOR 6081 Power Supply Unit and Charger.

Connecting SAILOR 6080 units	Connector
SAILOR 6081	P1
SAILOR 6081 + 1 SAILOR 6080	P1 + P2
SAILOR 6081 + 2 SAILOR 6080	P1 + P2 + P3
SAILOR 6081 + 3 SAILOR 6080	P1 + P2 + P3 + P4

For instructions how to connect DC input from an additional SAILOR 6080 when upgrading, see *Upgrading with additional SAILOR 6080 units* on page 47.

2.2.4.13 Crosslink interface (X8) when sharing a battery

If several SAILOR 6081 Power Supply Unit and Charger units (in primary and duplicated segments) are installed and share the same battery, you must connect them in order to control the charging load for the shared battery. This ensures dynamic adjustments to the requirements for charging the battery and all DC outputs. The crosslink ensures that the maximum charging current is not exceeded.

The maximum charging current and the float voltage can be configured, for further details see *Customizing battery settings* on page 33.

For crosslink use 2 x 2 x 0.5 mm (AWG 20) twisted pair shielded marine installation cable.

Connect the cable to the connector marked **X8** of each power supply according to the specifications in the table below:

Crosslink (CAN bus cable)	
Connector type	Spring loaded terminal
Wire cross section	Up to 0.75 mm ² (AWG 18)
Red	CAN +15 V
Black	CAN 0 V
White	CAN_H
Blue	CAN_L

2.2.5 Jumpers

2.2.5.1 Jumper J500 for crosslink interface (X-LINK POWER)

The jumper **J500** has two functions:

1. Enabling power to the X-LINK (crosslink) connection.
2. Identifying the default power supply as the power supply in the primary segment.

In order to prevent ground loops, the X-LINK POWER interface is isolated. For the interface to work properly, place the jumper **J500** in one power supply in the primary segment.

Important

Mount the jumper **J500** on one power supply — and **only ONE power supply in the primary segment**.

This will break the isolation on the unit and provide a 15 V DC for the interface. This supply is fused by an auto-reset fuse with a maximum break current of 200 mA.

The jumper **J500** marks also the default power supply in the primary segment. The SAILOR 6081 can provide various status and alarm information. To forward alarms correctly to the connected devices (MF/HF, VHF, Inmarsat C, etc), it is important that each SAILOR 6081 is configured correctly with information about the connected equipment. For configurations with one SAILOR 6081 in one segment this can be done with the X-LINK jumper J500.

- Jumper **J500** mounted: The SAILOR 6081 drives all equipment in the **primary** segment.
- Jumper **J500** not mounted: The SAILOR 6081 drives all equipment in the **duplicated** segment.

In configurations with several SAILOR 6081 units in one segment you must configure the individual SAILOR 6081 units with a software tool. For further details see *Setup of several SAILOR 6081 units in a segment* on page 22.

2.2.5.2 Jumper W503 for termination of crosslink

Terminate the crosslink with a jumper in W503 in the first and the last SAILOR 6081 Power Supply Unit and Charger.

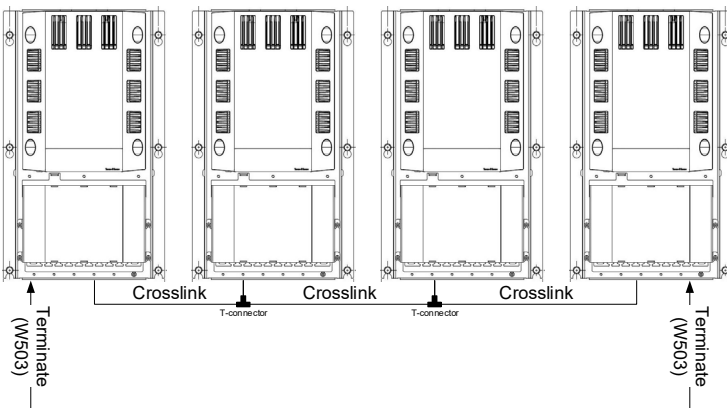

Micro NMEA 2000 T-connector: Part number 406100-931

NMEA 2000 Micro Device Cable (6 m): Part number 406100-040

2.2.6 Configuring multiple SAILOR 6081 Power Supply Unit and Charger units

2.2.6.1 Example 1: 2 SAILOR 6081 without sharing the battery (no crosslink)

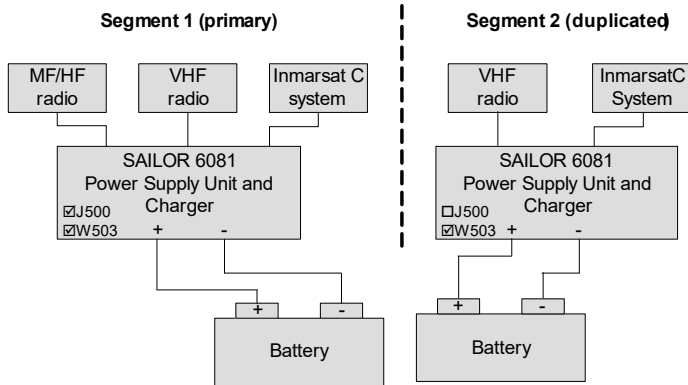

2.2.6.2 Example 2: 2 SAILOR 6081 share one battery (crosslink)

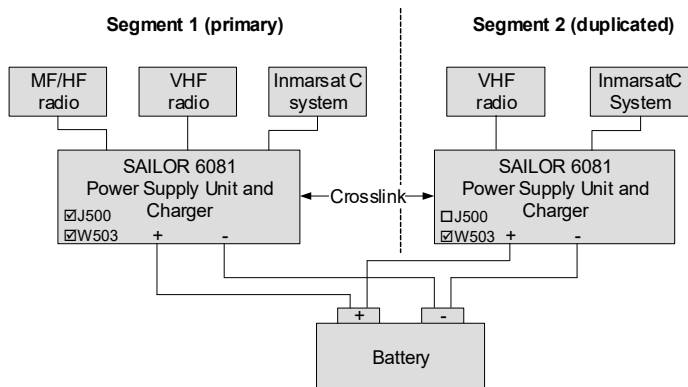

2.2.6.3 Example 3: 3 SAILOR 6081, 2 sharing a battery

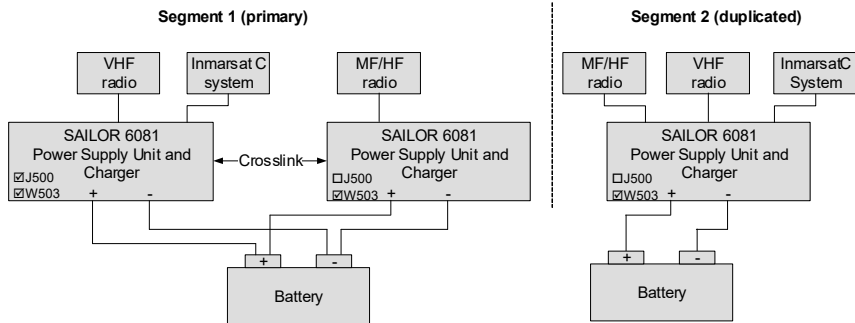

Important

Further configuration is needed, as there is more than one SAILOR 6081 in one segment (no jumper in J500). Read carefully the following section.

2.2.6.4 Setup of several SAILOR 6081 units in a segment

You must setup each SAILOR 6081 with the following information so that each SAILOR 6081 Power Supply Unit and Charger can provide alarms etc. to the relevant connected equipment:

- Is the SAILOR 6081 part of the primary or duplicated segment?
- Which devices (MF/HF, VHF, Inmarsat mini-C) does the SAILOR 6081 power?

Once correctly set up, the alarms and status information from the SAILOR 6081 are correctly displayed in the respective system.

2.2.6.5 Example 4: 4 SAILOR 6081, all sharing a battery

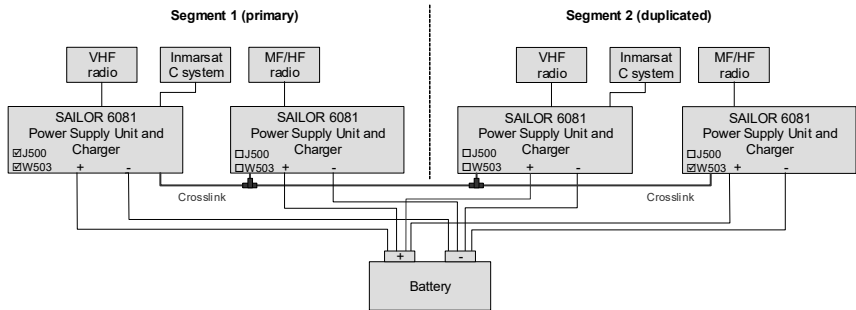

Important

Further configuration is needed, as there is more than one SAILOR 6081 in one segment (no jumper in J500). Read carefully *Setup of several SAILOR 6081 units in a segment* on page 22.

2.2.6.6 Connectors on the SAILOR 6080 Power Supply



On/off switch	AC input	AC alarm	DC 1	DC 2	Battery
		Not used		Not used	Not used

The following connectors on the SAILOR 6080 are used:

- AC input
- Black 10-pin plug for control data
- One DC out (DC1 or DC2)

The following connectors on the SAILOR 6080 are not used:

- AC alarm
- Battery
- One DC out (DC1 or DC2)

Note | The two 20 A fuses of the SAILOR 6080 are not used if the SAILOR 6080 is part of a SAILOR 6081 installation.

Service and repair

The SAILOR 6081 Power Supply Unit and Charger is designed to operate without preventive maintenance.

Repair or repair attempts performed by unqualified personnel may limit the warranty. The warranty on the system is defined and outlined by the distributor that supplied the SAILOR 6081 Power Supply Unit and Charger.

3.1 Support, repair and service

3.1.1 Contact for support

For support contact the distributor that supplied the SAILOR 6081 Power Supply Unit and Charger. For further information on warranty and service, you may also use the Cobham SATCOM home page at www.cobham.com/satcom.

3.1.2 Repair and servicing

The device does not require maintenance and adjustment apart from routine checking of its installation.



Warning! Never insert or remove a power supply while its power switch is in the On (I) position. Make sure the power switch is Off (O) first.

Important

In case of malfunction do not open the SAILOR 6080 Power Supply but send it in for repair. For information how to proceed see *Returning units for repair* on page 31. The SAILOR 6081 charger option board is replaceable and available as spare part S-60-129418.

3.1.3 Status indicators (LED)

The status LEDs are on the connector panel under the black cover.

3.1.3.1 General status LED

- Error-free operation: The green LED is constantly lit.
- Operation with errors:
 - One flash of the green LED: AC alarm
 - Two flashes of the green LED: Battery alarm
 - Three flashes of the green LED: Device error

3.1.3.2 Battery status LED

- Battery is fully charged: The green LED is constantly lit.
- Battery is being pre-charged: One flash of the green LED.
- Battery is being charged: Two flashes of the green LED.
- Battery delivers power: Three flashes of the green LED.
- Battery not detected: The LED is off.

3.1.3.3 Ethernet status LED

- Error-free operation: The green LED is constantly lit.
- No Ethernet connection: The LED is off.
- Operation with errors: One flash of the green LED.

3.1.3.4 X-LINK status LED.

- Active. Error-free operation: The green LED is constantly lit.
- No X-Link: The LED is off.
- Operation with errors: One flash of the green LED.

3.2 Alert messages

Alert messages in the Message Terminal for MF/HF setup:

Title	Description
AC power supply alarm	A power outage has occurred.
AC power supply alarm	No communication with the power supply
Battery alarm	The battery voltage is above the configured limit of (set value) V.
	The battery voltage is below the configured limit of (set value) V.
	The battery temperature is above the configured limit of (set value) °C.
	The battery temperature is below the configured limit of (set value) °C.
External alarm	AUX 1 alarm.
	AUX 2 alarm.
AC power supply alarm	Power supply crosslink error.

Alert messages in the Message Terminal for Inmarsat mini-C setup:

Title	Description
AC Power Outage	Check AC power distribution. A power outage has occurred
BATT VOLT High	The battery voltage is above the configured limit of xx.x V
BATT VOLT Low	The battery voltage is below the configured limit of xx.x V

Title	Description
BATT TEMP High	The battery temperature is above the configured limit of xx <degree-sign>
BATT TEMP Low	The battery temperature is below the configured limit of xx <degree-sign>
AUX 1	AUX 1 alert
AUX 2	AUX 2 alert
INTERN TEMP High	Check power supply. Internal power supply temperature too high
PS Crosslink ERR	Check power supply crosslink. Power supply crosslink error.
PS COMM Lost	Check LAN-cable to power supply. No communication with power supply

3.3 Exchanging the fuses

The SAILOR 6081 Power Supply Unit and Charger has separately fused DC outputs. To exchange a fuse for one of the DC outputs, do as follows:

1. Minimize the current drawn by switching off as many devices as possible.



Warning! Use insulated tools and pay attention not to introduce accidentally a short circuit at the battery terminals.

2. Locate the fuse to be exchanged on the connector panel.
3. Take out the blown fuse and put in a new of the same size.

Connector	Fuse type	Fuse size
X11, X12	ATO blade	20 A
P1, P2, P3, P4	ATO blade	20 A
X13, X14	ATO blade	10 A
X2	S-33-205377-050	50 A
X10	S-33-205377-050	50 A

The SAILOR 6080 Power Supply has a fuse to secure the AC input.

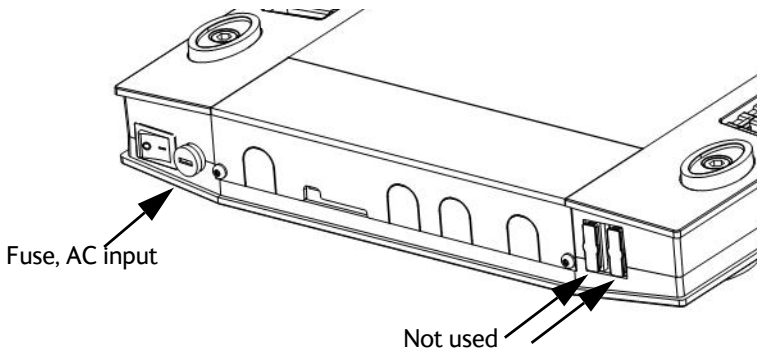

To exchange the AC fuse, do as follows:

1. Locate the fuse, it is accessible from outside the housing. It is positioned next to the on/off switch.
2. Turn the fuse holder and extract it.
3. Take out the old fuse and insert a new one (type: 5x20 mm, 6.3 AT).
4. Insert and fasten the fuse holder.



Caution! If the AC fuse is blown directly after being replaced there might be a critical fault in the SAILOR 6081 Power Supply Unit and Charger. Return the unit for repair.

3.4 Returning units for repair

Should your Cobham SATCOM product fail, please contact your dealer or installer, or the nearest Cobham SATCOM partner. You will find the partner details on www.cobham.com/satcom, **Technical Service Partner List**. You can also access the **Cobham SYNC Partner Portal** at <https://sync.cobham.com/satcom>, which may help you solve the problem. Your dealer, installer or Cobham SATCOM partner will assist you whether the need is user training, technical support, arranging on-site repair or sending the product for repair. Your dealer, installer or Cobham SATCOM partner will also take care of any warranty issue.

3.4.1 Repacking for shipment

Should you need to send the product for repair, please read the below information before packing the product.

The shipping carton has been carefully designed to protect the SAILOR 6081 Power Supply Unit and Charger and its accessories during shipment. This carton and its associated packing material should be used when repacking for shipment. Attach a tag indicating the type of service required, return address, part number and full serial number. Mark the carton FRAGILE to ensure careful handling.

Note

Correct shipment is the customer's own responsibility.

If the original shipping carton is not available, the following general instructions should be used for repacking with commercially available material.

1. Wrap the defective unit in heavy paper or plastic. Attach a tag indicating the type of service required, return address, part number and full serial number.
2. Use a strong shipping container, e.g. a double walled carton.
3. Protect the front- and rear panel with cardboard and insert a layer of shock-absorbing material between all surfaces of the equipment and the sides of the container.
4. Seal the shipping container securely.
5. Mark the shipping container FRAGILE to ensure careful handling.

Failure to do so may invalidate the warranty.

Customizing battery settings

4.1 Battery settings

To customize some parameters and alert thresholds use the SAILOR 6018 Message Terminal or a software tool. The communication is via the Ethernet interface. The following parameters can be changed:

Parameter	Default value	Allowed range
Maximum charging current ^a	10 A	1 A – 40 A
Maximum charging voltage ^b	28.8 V	26 V – 31 V
Float voltage ^b	27.2 V	24 V – 29.5 V
Min. battery alert voltage	23.5 V	10 V – 30 V
Max. battery alert voltage	29.5 V	20 V – 35 V
Recharge voltage ^c	25 V	20 V – 26 V
Min. alert temperature ^d	-5 °C	-20 – +25 °C
Max. alert temperature ^d	55 °C	+25 – +110 °C

- a. The charging current may be lower depending on the currently available output power.
- b. All voltages at 20 °C. If a temperature sensor is mounted the voltages are compensated with -36 mV/°C.
- c. If the recharge voltage is higher than the float voltage, recharging starts only when the battery voltage reaches the Recharge voltage level.
- d. Only relevant if a battery temperature sensor is installed.

4.2 Changing the battery settings

Note

You need the password 1234 for the Message Terminal to view and edit the battery settings.

4.2.1 Viewing the battery settings

You can view the battery settings¹ in the SAILOR 6018 Message Terminal. Use the touchscreen to enter the menu **System**, then **Power**.

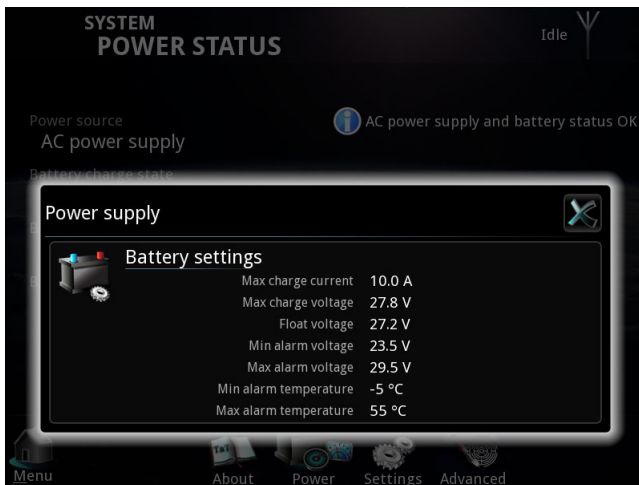

To display the screen for editing battery settings, press **Battery settings** or anywhere else in the window **Power supply**.

1. The recharge voltage is not displayed in the SAILOR 6018 Message Terminal.

4.2.2 Editing the battery settings

Edit the battery settings¹ by using the touchscreen.

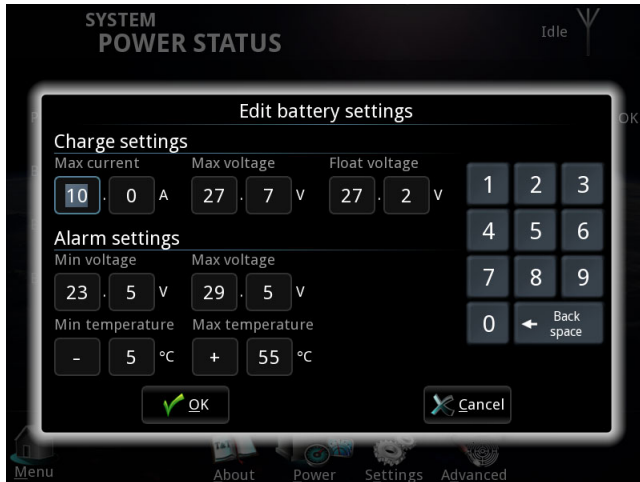

1. The recharge voltage cannot be set in the SAILOR 6018 Message Terminal.

Technical specifications

A.1 SAILOR 6081 Power Supply Unit and Charger

The following tables show the electrical and environmental specifications of the SAILOR 6081 Power Supply Unit and Charger.

Output power	SAILOR 6081	SAILOR 6081 + 1 SAILOR 6080	SAILOR 6081 + 2 SAILOR 6080	SAILOR 6081 + 3 SAILOR 6080
100 - 240 VAC Continuous Peak (2 min., 10% duty cycle)	300 W 370 W	600 W 740 W	900 W 1110 W	1200 W 1480 W
90 - 100 VAC Continuous Peak (2 min., 10% duty cycle)	270 W 333 W	500 W 616 W	730 W 899 W	960 W 1182 W

Specifications	Value
DC output 15 VDC (X15) DC output (X10) DC to battery (X2)	14.25 VDC to 15.75 VDC 24 VDC to 31.2 VDC 8 VDC to 31.2 VDC (Precharge: 8 VDC to 23 VDC)
Alarm	In case of AC power failure or if battery power is outside allowed range
IP rating	IP 30
Operating temperature	-15° to +55° C
Storage temperature	-40° to +80° C
Cooling	The SAILOR 6081 must be placed in a ventilated area with free space around all sides, except the bottom side.
Survival temperature (power on)	-40° to +80° C
Dimensions SAILOR 6081: SAILOR 6081 + 1 SAILOR 6080: SAILOR 6081 + 2 SAILOR 6080: SAILOR 6081 + 3 SAILOR 6080:	H: 66 mm, L: 590 mm, W: 355 mm H: 112 mm, L: 590 mm, W: 355 mm H: 158 mm, L: 590 mm, W: 355 mm H: 204 mm, L: 590 mm, W: 355 mm
Weight SAILOR 6081: SAILOR 6081 + 1 SAILOR 6080: SAILOR 6081 + 2 SAILOR 6080: SAILOR 6081 + 3 SAILOR 6080:	6.2 kg 10.1 kg 14 kg 17.9 kg
Compass safe distance	30 cm

A.2 SAILOR 6080 Power Supply

The following table shows the specifications of the SAILOR 6080.

Specifications	Value
Output power at 100 VAC - 240 VAC	300 W continuous 370 W peak (max. 2 min. with 10% duty cycle) ^a
Output power at 90 VAC - 100 VAC	270 W continuous 333 W peak (max. 2 min. with 10% duty cycle) ^a
DC output (nominal), without control, if not used in SAILOR 6081 with up to 4 SAILOR 6080.	31.2 VDC at 0 A 29.3 VDC at 10 A 28.7 VDC at 13 A
AC input voltage	100-240 VAC nominal, 90-264 VAC operating
Alarm in case of	AC power failure
IP rating	IP 30
Operating temperature	-15° to +55° C
Storage temperature	-40° to +80° C
Cooling	The SAILOR 6080 must be placed in a ventilated area with free space around all sides of the unit, except the bottom side.
Heat dissipation	31,104 Kcal / hour

- a. Output power capability depends on the mounting position (horizontal or vertical), input voltage, ambient temperature and ventilation at the place of installation.

Specifications	Value
Survival temperature (power on)	-40° to +80° C
Dimensions	H: 46.5 mm, L: 354 mm, W: 265 mm
Weight	Approx. 3.7 kg
Compass safe distance	30 cm

Upgrade

B.1 Overview

B.1.1 Upgrading to 740 W, 1110 W or 1480 W peak output power

You can upgrade the SAILOR 6081 Power Supply Unit and Charger on site with up to 3 SAILOR 6080 Power Supply units to increase the DC power output up to 1480 W peak. The upgrade can be made on site by trained service personnel.

Model	Peak output power	Upgrade kit
SAILOR 6081	Max. 370 W	—
SAILOR 6081 + 1 SAILOR 6080	Max. 740 W	Included. Spare kits can be ordered (S-676081).
SAILOR 6081 + 2 SAILOR 6080	Max. 1110 W	
SAILOR 6081 + 3 SAILOR 6080	Max. 1480 W	Not included. Order number: S-406081-004

The following image shows a SAILOR 6081 with 2 SAILOR 6080 connected and an open connector panel.

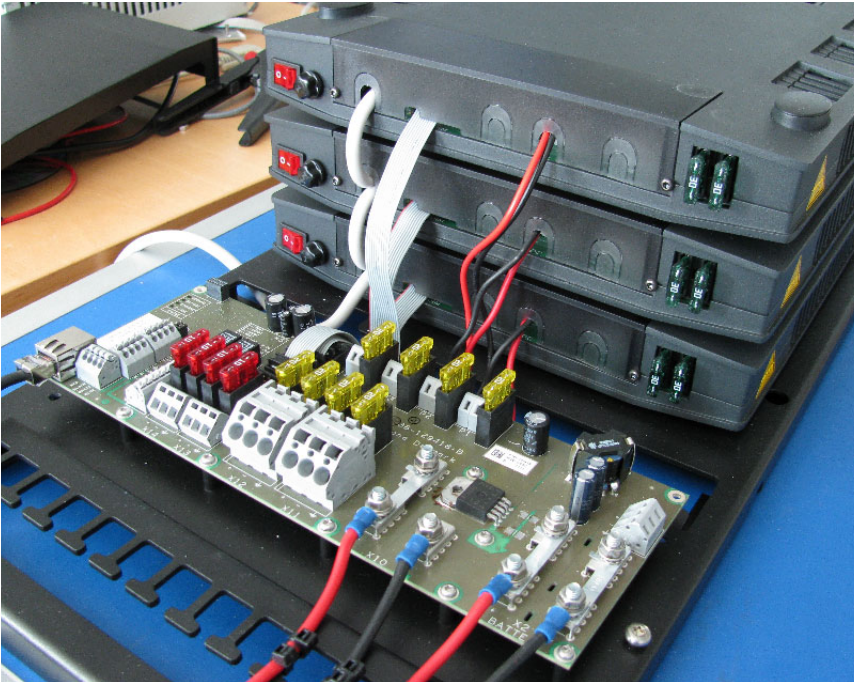

When upgrading, you must connect:

6. Mains AC from additional SAILOR 6080 to Mains AC on the original power supply.¹
7. Control data connector from SAILOR 6080 to the connector in the SAILOR 6081 marked C2, C3, or C4.

1. For easy access you may connect the incoming AC Power to the uppermost unit.

8. DC output from SAILOR 6080 to the connector in the SAILOR 6081 marked P2, P3, or P4.



Caution! Use different colors for DC+ and DC- to make sure you connect to the right polarity! Note that the connectors on the SAILOR 6080 are oriented opposite to the connectors on the SAILOR 6081, so the plus and minus cables cross each other (see photo in previous page).

For a detailed description how to proceed see *Upgrading SAILOR 6081 with 1 SAILOR 6080 (detailed)* on page 47.

B.1.1.1 Upgrading a SAILOR 6081 with 1 SAILOR 6080

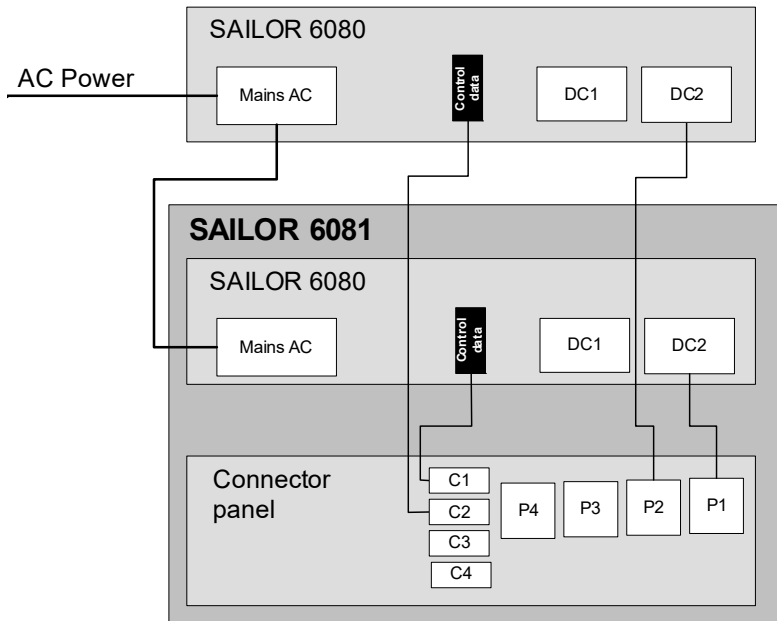

B.1.1.2 Upgrading a SAILOR 6081 with 2 SAILOR 6080

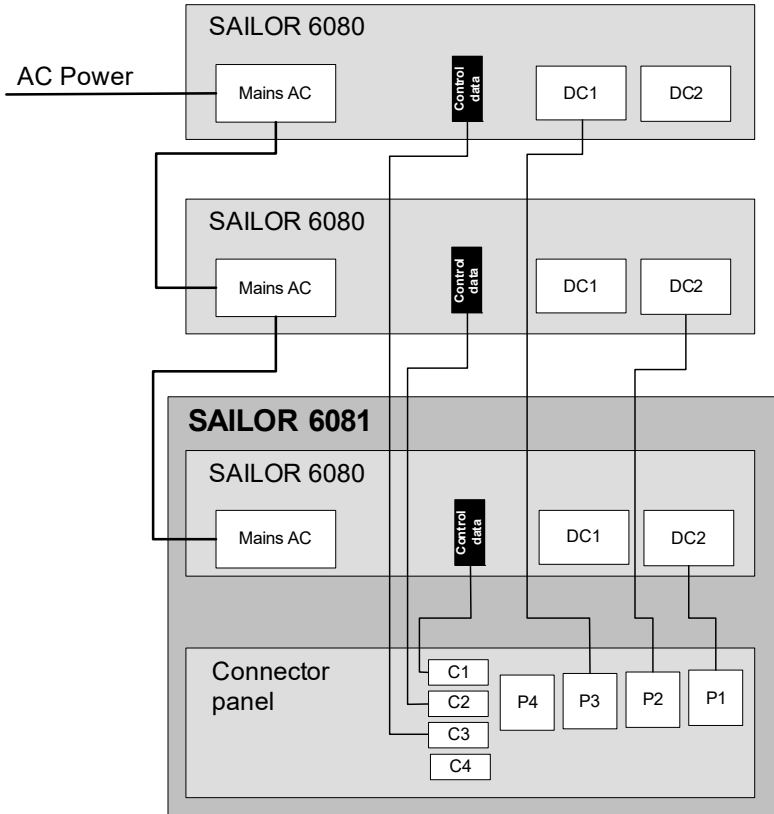

B.1.1.3 Upgrading a SAILOR 6081 with 3 SAILOR 6080

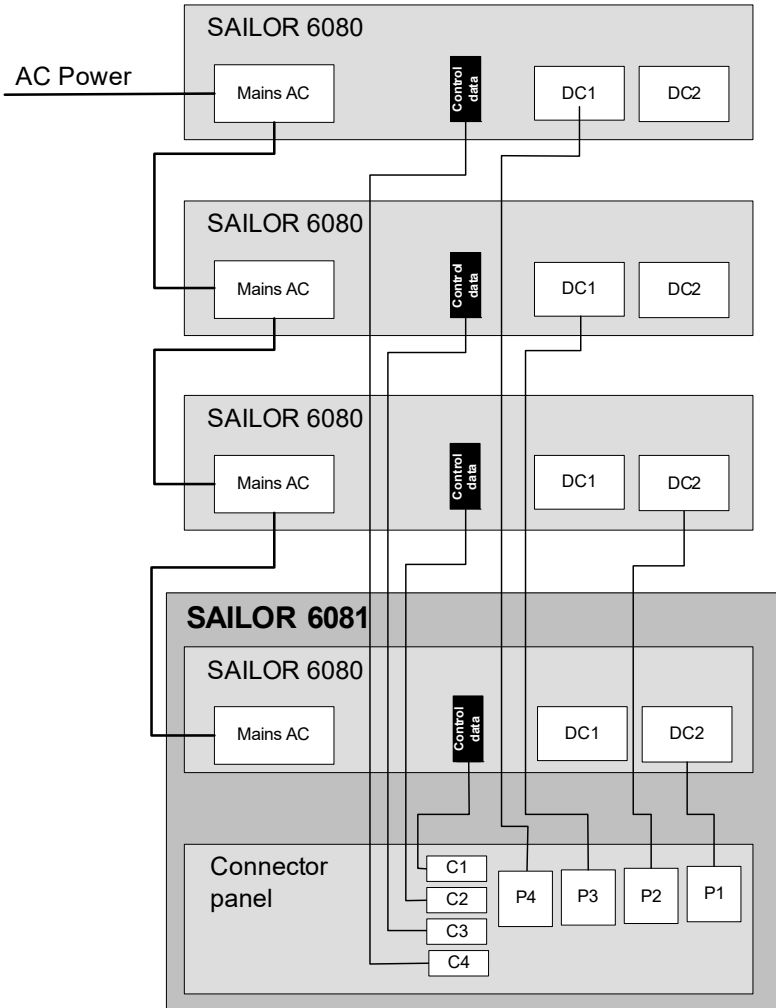

Upgrade

B.1.1.4 Connectors involved

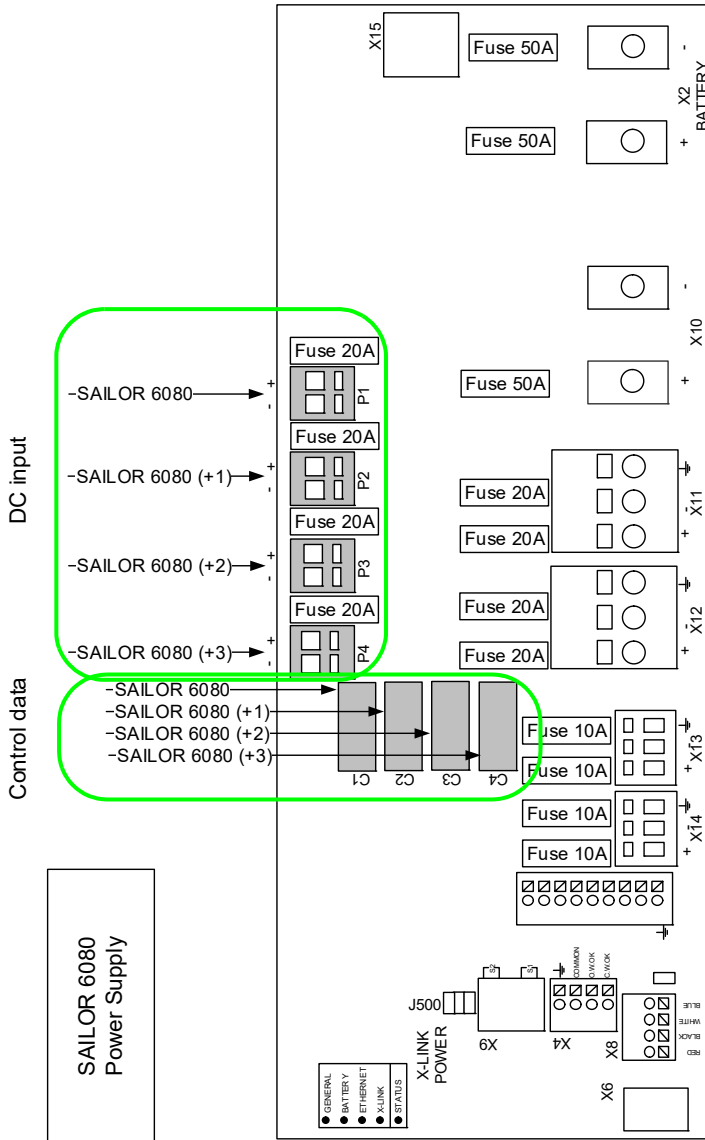

B.2 Upgrading with additional SAILOR 6080 units

The following drawing shows the SAILOR 6080 Power Supply and the position of the mounting holes.

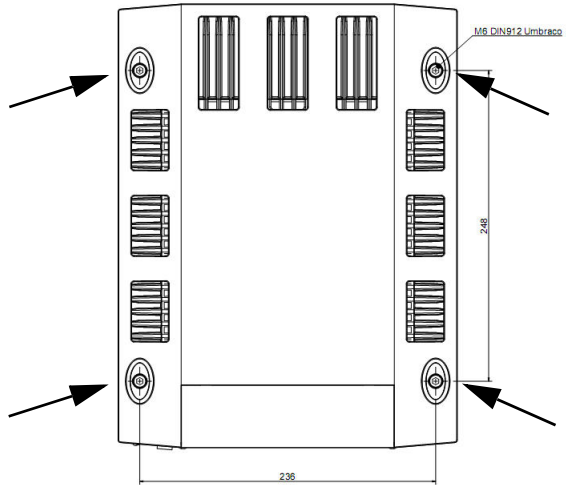

B.2.1 Upgrading SAILOR 6081 with 1 SAILOR 6080 (detailed)

To add 1 SAILOR 6080, do as follows:

1. **Switch off** the SAILOR 6081 Power Supply Unit and Charger.
2. **Disconnect** the battery.
3. **Remove the 4 mounting bolts** holding the power supply on the wall-mount tray.

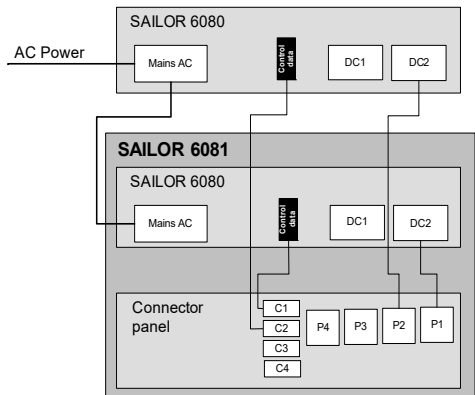

4. **Prepare SAILOR 6081:**
 - a) Take off the protective lid.
 - b) Connect the cable for Mains AC for SAILOR 6080.
5. **Prepare SAILOR 6080:**
 - a) Take off the protective lid.
 - b) Attach DC power cables (195 mm length) to DC2.¹
 - c) Attach black flat cable (225 mm length) to control data plug in SAILOR 6080.
6. **Connect the SAILOR 6080 units to SAILOR 6081:**
 - a) Put the SAILOR 6080 in place.
 - b) Connect AC cables as shown in the illustration.
 - c) Connect DC2 from SAILOR 6080 to P2 in SAILOR 6081.¹
 - d) Connect control data from SAILOR 6080 to C2 in SAILOR 6081.
7. **Attach the protective lids** when all cables are connected.
8. **Fasten the SAILOR 6080 unit to the wall mount tray** with the 4 mounting bolts (M6x100 mm).

Important

To ensure adequate cooling of the AC/DC Power Supplies an unobstructed space of minimum 5 cm must be maintained around all sides of the group of units (except between the units and the bottom side).

1. Use different colors for DC+ and DC-! See Caution on page 43.

B.2.2 Upgrading SAILOR 6081 with 2 SAILOR 6080 units (detailed)

To add 1 SAILOR 6080, proceed as described in *Upgrading SAILOR 6081 with 1 SAILOR 6080 (detailed)* on page 47.

1. Repeat steps 1 to 5 from the previous page.

Note Steady the upper SAILOR 6080 manually until the additional SAILOR 6080 is placed on top and the mounting bolts are inserted and fastened.

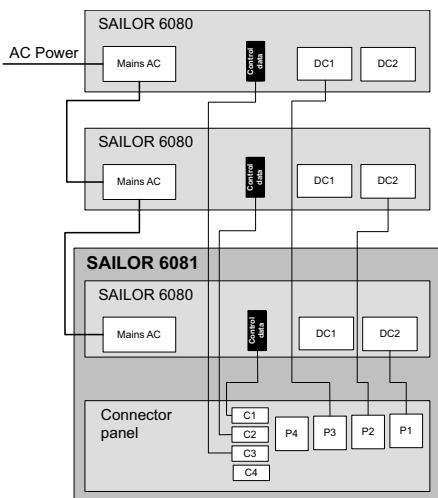

2. **Connect SAILOR 6080 to SAILOR 6081:**
 - a) Put the SAILOR 6080 in place.
 - b) Connect AC cable from SAILOR 6081 to SAILOR 6080.
 - c) Connect DC1 from SAILOR 6080 to P3 in SAILOR 6081.¹
 - d) Connect control data from SAILOR 6080 to C3 in SAILOR 6081.
3. **Attach the protective lids** when all cables are connected.
4. **Fasten all units to the wall mount tray** with the 4 mounting bolts (M6x140 mm).

Important

To ensure adequate cooling of the AC/DC Power Supplies an unobstructed space of minimum 5 cm must be maintained around all sides of the group of units (except between the units and the bottom side).

1. Use different colors for DC+ and DC-! See Caution on page 43.

Note

When adding 3 SAILOR 6080 you need the installation kit S-406081-004 which includes a mounting bracket and long mounting bolts.

To add 3 SAILOR 6080, do as follows:

1. **Switch off** the SAILOR 6081 Power Supply Unit and Charger.
2. **Disconnect** the battery.
3. **Remove the 4 mounting bolts** holding the power supply on the wall-mount tray.
4. Mount the long bolts from the installation kit in the wall mount tray.
5. **Prepare SAILOR 6081:**
 - a) Take off the protective lid.
 - b) Connect the cable for Mains AC for SAILOR 6080.
6. **Prepare the SAILOR 6080 units:**
 - a) Take off the protective lid.
 - b) Attach black DC power cable (195 mm length) to DC2.
 - c) Attach black flat cable (225 mm length) to control data plug in SAILOR 6080.
 - d) Connect the cable for Mains AC for the next SAILOR 6080 (see illustration).
7. **Connect the SAILOR 6080 units to SAILOR 6081:**
 - a) Put all SAILOR 6080 units in place.
 - b) Attach the mounting bracket and fasten it with the cap nuts.
 - c) Connect AC cable for SAILOR 6080 units as shown in the illustration.

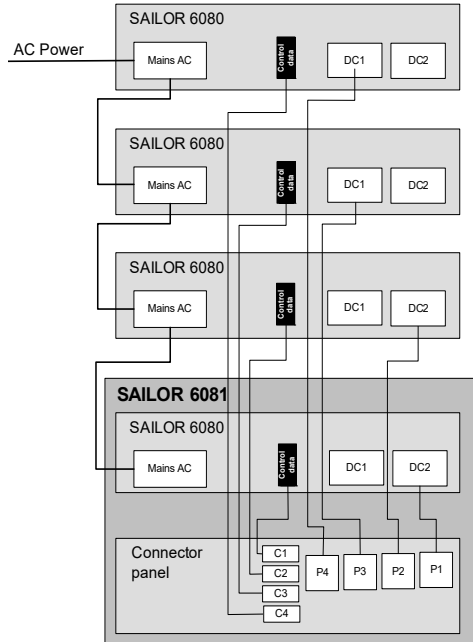

- d) Connect DC2 from SAILOR 6080 to P2, P3 and P4 in SAILOR 6081.¹
- e) Connect control data from SAILOR 6080 to C2, C3 and C4 in SAILOR 6081.

8. Attach the protective lids when all cables are connected.

Important

To ensure adequate cooling of the AC/DC Power Supplies an unobstructed space of minimum 5 cm must be maintained around all sides of the group of units (except between the units and the bottom side).

B.2.4 Removing the protective lid and cut-out for cables

To remove the protective lid unscrew the two screws (M3x7mm Torx-8) as shown in the picture.

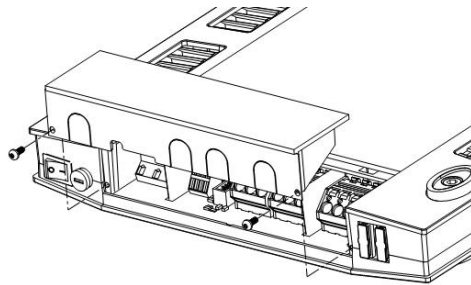

To make room for the connector cables, remove the appropriately sized U-shaped cutout. Example: To use AC Mains and one DC connector, remove the U-shaped cutouts shown in the picture.

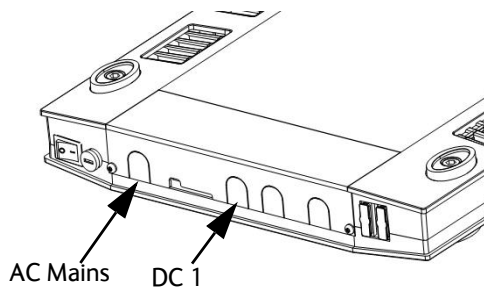

1. Use different colors for DC+ and DC-! See Caution on page 43.

Approvals

C.1 IEC 60945

The SAILOR 6081 Power Supply Unit and Charger is compliant with the IEC standard 60945.

C.2 Wheelmark

The SAILOR 6081 Power Supply Unit and Charger is Wheelmark approved. Refer to the certificate of the Wheelmark approved system, of which the SAILOR 6081 Power Supply Unit and Charger is a part.

A

AC Alternating Current

D

DC Direct Current

G

GMDSS Global Maritime Distress and Safety System

GND Ground

H

HF High Frequency. The frequency band between 3 and 30 MHz. Used for medium and long range terrestrial radio communication.

I

IEC International Electrotechnical Commission is an international standards organization that prepares and publishes International Standards for all electrical, electronic and related technologies.

IP

International Protection Rating, sometimes also interpreted as Ingress Protection Rating, consists of the letters IP followed by two digits and an optional letter. It classifies the degrees of protection provided against the intrusion of solid objects (including body parts like hands and fingers), dust, accidental contact, and water in electrical enclosures.

L

LED Light Emitting Diode

M

MF Medium Frequency. Radio frequencies (RF) in the range of 300 kHz to 3 MHz. Navtex, which is part of the current Global Maritime Distress Safety System occupies 518 kHz and 490 kHz for important digital text broadcasts.

N

NMEA National Marine Electronics Association (standard). A combined electrical and data specification for communication between marine electronic devices such as echo sounder, sonars, anemometer (wind speed and direction), gyrocompass, autopilot, GPS receivers and many other types of instruments. It has been defined by, and is controlled by, the U.S.-based National Marine Electronics Association.

V

VHF Very High Frequency. 30-300 MHz, a "straight-line" signal used for short-distance terrestrial communication and navigation.

X

X-LINK Cross link

A

- AC alarm
 - displayed, 22
- add further power supplies, 41
- alarm
 - display in connected units, 22
 - messages, 27
- alarm temperature
 - battery, 33
- applications, 4
- approval
 - maritime, 3

B

- battery
 - sharing, 18
- battery alarm
 - program, 33
 - temperature, 33
 - voltage, 33
- battery charge, 1
- battery settings, 33

C

- CE compliance, 53
- charging current
 - max, 33
- charging voltage
 - max, 33
- chassis
 - ground, 10
- combining
 - several power supplies, 41
- Compass safe distance, 38, 40
- conformity, 53
- connector
 - overview, 8

- cooling requirements
 - several units, 48, 49, 52
- cross link
 - cable, 20
 - T-connector, 20
- crosslink
 - termination, 20
- customizing, 33

D

- document number
 - this manual, i
- drain wire
 - grounding, 10

F

- features, 3
- float voltage, 33
- fuse
 - AC input, 11
 - battery, 12, 13, 14
 - battery connector, 14
 - DC output X10, 12
 - DC output X11 and X12, 12
 - DC output X13 and X14, 13
 - MAINS AC, 11

G

- grounding, iii, 10

I

- IEC 60945, 3
- input
 - AC, 3
- installation
 - more power supplies, 41

IP rating, 3, 38, 39

L

lid

remove, 52

M

manual

document number, i

maximum charging current
programming, 33

N

NMEA 2000 Micro Device Cable, 20

NMEA 2000 T-connector, 20

O

outline drawing, 6

P

peak output power

increase, 41

programming

battery alarm, 33

maximum charging current, 33

protective lid

remove, 52

R

recharge voltage, 33

repackaging, 32

repair, 25

returning units for repair, 31

S

safety summary, iii

servicing, 25

sharing a battery, 18

specifications, 37

support

contact, 25

T

technical specifications, 37

termination

crosslink, 20

U

unpacking, 5

upgrade, 41

W

warranty, 31

