

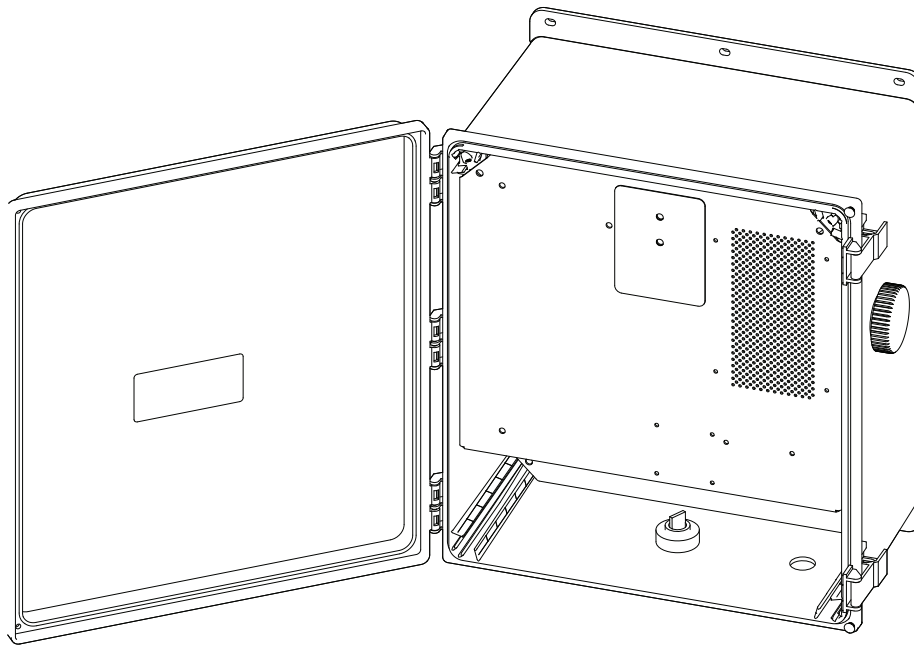

NETCOM MODEL ADH NEMA

AUTOMATIC AIR DEHYDRATOR WITH ETHERNET COMMUNICATIONS



FEATURES & BENEFITS

- Provides dry pressurized air to ensure signal quality of antenna waveguide and dielectric coaxial cable
- Highly configurable to meet the needs of wide ranging applications
- Programmable operating pressure range: 0.3 psig - 7.50 psig (20.68mbar - 517mbar)
- Brushless compressor for long life
- Future-proof software based features allow updates and upgrades while in service
- Remote monitoring and control with web interface or SNMP
- Configurable Master/Slave operation
- Ethernet, RS-422/485, RS-232 and alarm relay outputs
- Durable, light weight IP66, NEMA 4X enclosure
- Designed to allow minimal flex without damaging enclosure or components for mobile and other high vibration applications
- Optionally available with military style connectors
- Low energy use minimizes operational costs

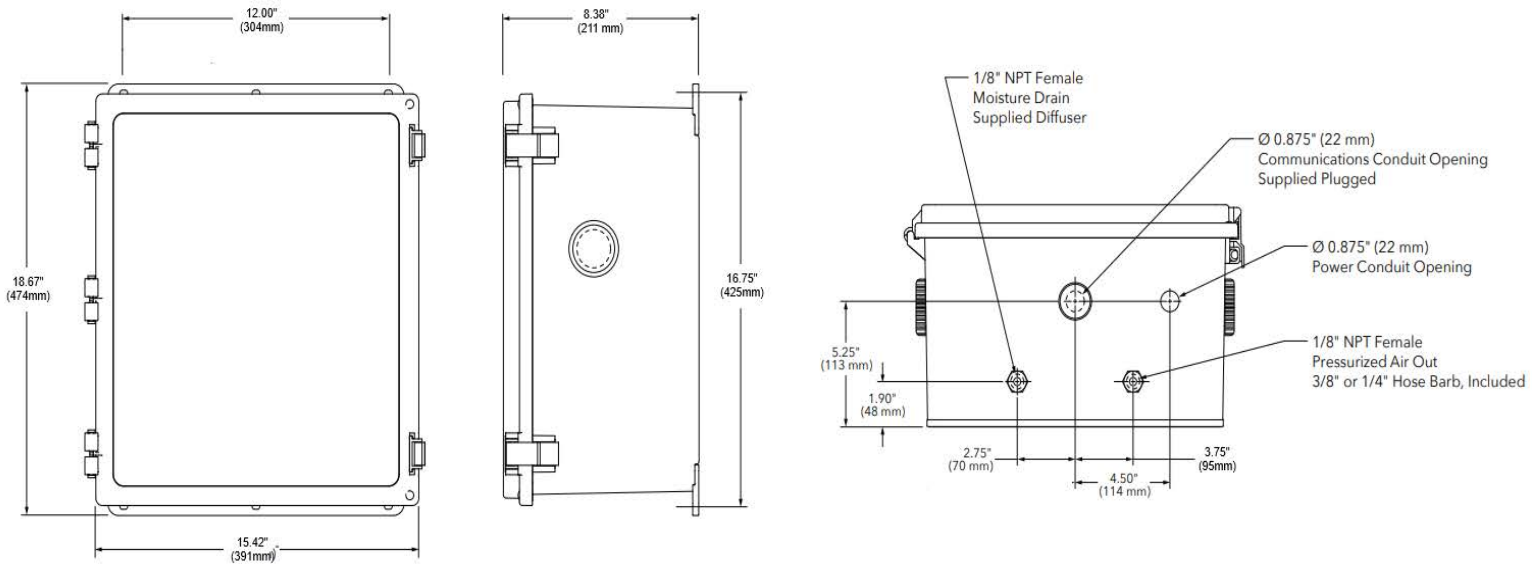

DESCRIPTION

The ADH NETCOM automatic dehydrator supplies low pressure dry air to keep waveguide and coaxial cable dry. Output pressure is configurable from 0.30 psig to 7.50 psig (20.68mbar to 517mbar) in 0.01 psig (0.67mbar) increments. Factory default pressure is 0.5 psig (34.5mbar).

Operational monitoring and alarms are software based making them highly configurable in the field. Future software features can be installed while in service over the Internet or local Ethernet network.

The ADH NETCOM automatic dehydrator is Ethernet network ready. Units can be configured and monitored using either built in SNMP support or the web interface. Legacy system support is provided via RS-422/485 or RS-232 interfaces. Three programmable alarm relays are also included.

Communicated operational information includes

output pressure, duty cycle, temperature, compressor hours and air drying canister status.

The ADH NETCOM automatic dehydrator uses a brushless dual-diaphragm pump for long life. Dehydrator operates with exceptionally low noise and vibration levels. The air drying canisters use aluminum oxide desiccant for high efficiency.

The humidity sensor signals for regeneration based upon current dew point rather than at fixed time intervals for additional energy savings and long desiccant life.

The ADH NETCOM NEMA automatic dehydrator provides the same functionality as a standard ADH NETCOM in an environmentally sheltered IP66, NEMA 4X enclosure.

It is ideal for use with mobile satellite antenna installations and for outdoor mounting for pressurization systems localized to the antenna

pedestal. This outdoor configuration is also ideal for use in pressurization systems in remote locations such as along rail lines, pipe lines and at power distribution substations. While the NEMA enclosure keeps out moisture, the temperature control system allows operation down to -40°F (-40°C). The ADH NETCOM NEMA automatic dehydrator weighs just 24 lbs (10.9 kg).

For complete information describing its application, installation and features, please contact Customer Service or check on the web at www.networketi.com.

SPECIFICATIONS

GENERAL

Area of use Non-hazardous locations

Regeneration Method Automatic, demand
Maximum dew point -40° F/C

ENCLOSURE

Type INTEGRA® Polycarbonate Type 4X PREMIUM
Cover Attachment Hinged, lockable
Protection IP66, NEMA 4X
Dimensions 15.42" × 18.67" × 8.38"
(391mm × 474mm × 211mm)
Entries 1 × 0.88" (22mm) entry for supply power
2 × 0.63" (16mm) entry for dry pressurized air
and condensate discharge

POWER

Supply voltage 100-240 VAC, 50/60 Hz
Maximum current 2.0 amps @ 100VAC
Power usage 150 W max.
Heat dissipation 512 BTU/hr max. @150 W

OUTPUT

Flow rate 25.4 scfh (12 lpm)
Maximum pressure 7.5 psig (517mbar)
Internal safety relief valve 8 psig (552mbar)
Discharge port 1/8" NPT
3/8" or 1/4" hose barb (both included)
Display units SI (millibars); English (psig), default

ENVIRONMENTAL

Operating temperature -40°F to 130°F +/-2°F (-40°C to 55°C +/-1°C)
Storage temperature -40°F to 150°F (-40°C to 60°C)
Cold Start Pressurization will commence when internal
temperature reaches 32°F (0°C) or above; 11
minutes at -4°F (-20°C)

CONTROL

Protocols HTTP (Web Interface), SNMP, UDP, TFTP Configurable
Maximum pressure Range: 0.30 psig - 7.5 psig (20.68mbar - 517mbar),
Default: 0.50 psig (34.5mbar)
Minimum pressure Configurable Range: 0.20 psig - 7.4 psig (13.79mbar -
510mbar), Default: 0.30 psig (21mbar)
Low pressure alarm level User Configurable, Default: 0.15 psig (10mbar) User
High pressure alarm level Configurable, Default 1.5 psig (103.5mbar)
Alarm relays Contact Type - Form C, SPDT, reverse acting Ratings -
0.25 Amps @ 60 V
User Configurable, Defaults - Alarm Relay 1: Summary
Alarm, Alarm Relay 2: Low
Pressure Alarm, Alarm Relay 3: Over Pressure Alarm
Duty cycle alarm User Configurable, Default: 50%
Master/Slave Config. User Configurable, Default: Standard/Slave

ORDERING INFORMATION

ORDER NUMBER	DESCRIPTION
25896	ADH NETCOM NEMA Automatic Dehydrator, 100-240 VAC
25921	ADH NETCOM NEMA Automatic Dehydrator, AC w/ Mil-Spec Connectors, Type 1
23739	Mil-Spec Connector Accessory Kit (for 25896)
25922	ADH NETCOM NEMA Automatic Dehydrator, AC w/ Mil-Spec Connectors, Type 2
23883	Mil-Spec Type 2 Kit

LIMITED WARRANTY

ETI's two year limited warranty covering defects in workmanship and materials applies. Contact Customer Service for complete warranty information.

DISCLAIMER

ETI makes no representations or warranties, either expressed or implied, with respect to the contents of this publication or the products that it describes, and specifically disclaims any implied warranties of merchantability or fitness for any particular purpose. ETI reserves the right to revise this publication, and to make changes and improvements to the products described in this publication, without the obligation of ETI to notify any person or organization of such revisions, changes or improvements.

The ETI logo, We Manage Heat, and ADH are registered trademarks of ETI. NETCOM is a trademark ETI. Copyright © 2012 ETI. All rights reserved.