

FURUNO

OPERATOR'S MANUAL

SATELLITE COMPASS™

Model

SC-33

IMPORTANT NOTICES

General

- This manual has been authored with simplified grammar, to meet the needs of international users.
- The operator of this equipment must read and follow the instructions in this manual. Wrong operation or maintenance can void the warranty or cause injury.
- Do not copy any part of this manual without written permission from FURUNO.
- If this manual is lost or worn, contact your dealer about replacement.
- The contents of this manual and the equipment specifications can change without notice.
- The example screens (or illustrations) shown in this manual can be different from the screens you see on your display. The screens you see depend on your system configuration and equipment settings.
- Save this manual for future reference.
- Any modification of the equipment (including software) by persons not authorized by FURUNO will void the warranty.
- The following concern acts as our importer in Europe, as defined in DECISION No 768/2008/EC.
 - Name: FURUNO EUROPE B.V.
 - Address: Siriusstraat 86, 5015 BT, Tilburg, The Netherlands
- The following concern acts as our importer in UK, as defined in SI 2016/1025 as amended SI 2019/470.
 - Name: FURUNO (UK) LTD.
 - Address: West Building Penner Road Havant Hampshire PO9 1QY, U.K.
- All brand, product names, trademarks, registered trademarks, and service marks belong to their respective holders.

How to discard this product

Discard this product according to local regulations for the disposal of industrial waste. For disposal in the USA, see the homepage of the Electronics Industries Alliance (<http://www.eiae.org/>) for the correct method of disposal.

How to discard a used battery

Some FURUNO products have a battery(ies). To see if your product has a battery, see the chapter on Maintenance. If a battery is used, tape the + and - terminals of the battery before disposal to prevent fire, heat generation caused by short circuit.

In the European Union

The crossed-out trash can symbol indicates that all types of batteries must not be discarded in standard trash, or at a trash site. Take the used batteries to a battery collection site according to your national legislation and the Batteries Directive 2006/66/EU.



In the USA

The Mobius loop symbol (three chasing arrows) indicates that Ni-Cd and lead-acid rechargeable batteries must be recycled. Take the used batteries to a battery collection site according to local laws.

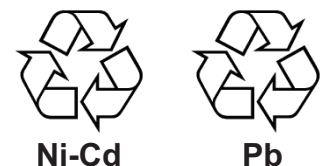

In the other countries

There are no international standards for the battery recycle symbol. The number of symbols can increase when the other countries make their own recycle symbols in the future.



SAFETY INSTRUCTIONS

The operator and installer must read the applicable safety instructions before attempting to install or operate the equipment.



WARNING

Indicates a potentially hazardous situation which, if not avoided, could result in death or serious injury.



CAUTION

Indicates a potentially hazardous situation which, if not avoided, can result in minor or moderate injury.



Warning, Caution



Prohibitive Action



Mandatory Action

Safety instructions for the operator



WARNING



Do not open the equipment.

Only qualified personnel should work inside the equipment.



Do not disassemble or modify the equipment.

Fire, electrical shock or serious injury can result.

Warning Label

A warning label is attached to the equipment. Do not remove the label. If the label is missing or illegible, contact a FURUNO agent or dealer about replacement.

WARNING
To avoid electrical shock, do not remove cover. No user-serviceable parts inside.
警告
感電の恐れあり。 サービスマン以外の方はカバーを開けないで下さい。内部には高電圧部分が多くあり、万一さわると危険です。

Name: Warning Label(1)
Type: 86-003-1011-3
Code No.: 100-236-233-10

Safety instructions for the installer



WARNING



Turn off the power at the switchboard before beginning the installation.

Fire or electrical shock can result if the power is left on.



Be sure that the power supply is compatible with the voltage rating of the equipment.

Connecting an incompatible power supply can cause fire or damage the equipment. The voltage rating appears on the inlet of power.



CAUTION



Observe the following compass safe distances to prevent interference to a magnetic compass:

	Standard compass	Steering compass
SC-33	0.45 m	0.40 m



Do not use high-pressure cleaners to clean this equipment.

This equipment has the waterproof rating outlined in the specifications, at the back of this manual. However, the use of high-pressure cleaning equipment can cause water ingress, resulting in damage to, or failure of, the equipment.

TABLE OF CONTENTS

- FOREWORD..... iv**
- SYSTEM CONFIGURATION vi**

- 1. MOUNTING 1**
 - 1.1 Equipment Lists 1
 - 1.2 Mounting Considerations..... 3
 - 1.3 Mounting Procedure 8

- 2. WIRING 10**
 - 2.1 NMEA 2000 Network Connection..... 10
 - 2.2 NMEA 0183 Network Connection..... 11
 - 2.2.1 How to connect the Cable Assembly (FRU-NMEA-NFF-R15/30)..... 11
 - 2.2.2 How to connect the Cable Replacement Kit (OP20-50)..... 12
 - 2.2.3 How to secure and waterproof the cable connections 15

- 3. ADJUSTMENTS 16**
 - 3.1 [GNSS Setup] Menu 16
 - 3.2 [Sensor] Menu 17
 - 3.3 [Input/Output] Menu..... 19
 - 3.4 [System] Menu..... 20
 - 3.5 [Advanced Sensor Setting] Menu 21

- 4. NMEA 2000 I/O DATA 23**
 - 4.1 Input Data 23
 - 4.2 Output Data 24

- 5. MAINTENANCE, TROUBLESHOOTING 26**
 - 5.1 Preventive Maintenance 26
 - 5.2 Troubleshooting..... 26

- MENU TREE AP-1**

- WHAT IS SBAS?..... AP-4**

- SPECIFICATIONS SP-1**

- PACKING LISTS A-1**

- OUTLINE DRAWING D-1**

- INTERCONNECTION DIAGRAM S-1**

FOREWORD

A Word to the Owner of the SC-33

Congratulations on your choice of the FURUNO SC-33 SATELLITE COMPASS™. We are confident you will see why the FURUNO name has become synonymous with quality and reliability.

Since 1948, FURUNO Electric Company has enjoyed an enviable reputation for quality marine electronics equipment. This dedication to excellence is furthered by our extensive global network of agents and dealers.

This equipment is designed and constructed to meet the rigorous demands of the marine environment. However, no machine can perform its intended function unless installed properly. Please carefully read and follow the recommended procedures for installation.

Thank you for considering and purchasing FURUNO equipment.

Features

The SC-33 outputs highly accurate heading, GNSS position data and speed and motion data for AIS, Tracked Target (TT) radar, autopilots, etc. Data is output in NMEA 2000® (NMEA2000 is a trademark of National Marine Electronic Association (the United States)) format, and with connection of the optional interface unit the data can be converted to NMEA 0183 format. Setting time is within three minutes and the follow-up performance is an excellent 45°/s.

- Heading accuracy of 0.4° RMS
- Perfect heading sensor for radar/TT, AIS, scanning sonar, etc.
- Outputs accurate heading, position, time, speed, course.
- Pitch and roll output in digital format for ship's motion correction
- A new SATELLITE COMPASS™ designed with FURUNO advanced GNSS kinematic technology.
- Data can be output in NMEA 2000 format
- Free from regular maintenance
- Aesthetically pleasing antenna fits nicely on recreational boats
- Outputs acceleration speed and angular velocity at installation

Software used in this product

This equipment uses the following open source software.

This product includes software to be licensed under the GNU General Public License (GPL) version 2.0, GNU Lesser General Public Software License (LGPL) version 2.0, Apache, BSD and others. The program(s) is/are free software(s), and you can copy it and/or redistribute it and/or modify it under the terms of the GPL version 2.0 or LGPL version 2.0 as published by the Free Software Foundation. Please access to the following URL if you need source codes.

https://www.furuno.co.jp/en/contact/cnt_oss_e01.html

Program No.

OS: 2051593-01.**

APL: 2051594-01.**

GNSS: 48505230**

** denotes minor modifications.

CE/UKCA declaration

With regards to CE/UKCA declarations, please refer to our website (www.furuno.com) for further information about RoHS conformity declarations.

Disclosure of Information about China RoHS

With regards to China RoHS information for our products, please refer to our website (www.furuno.com).

SYSTEM CONFIGURATION

Connection with the NMEA2000 network

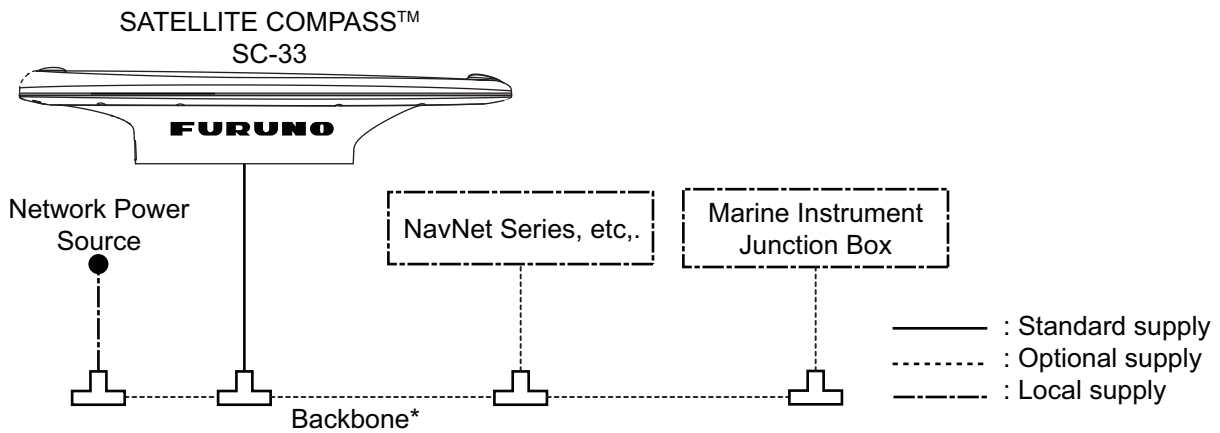

*: Termination resistors must be installed at both ends of the backbone.

Connection NMEA0183 connection with the IF-NMEASC

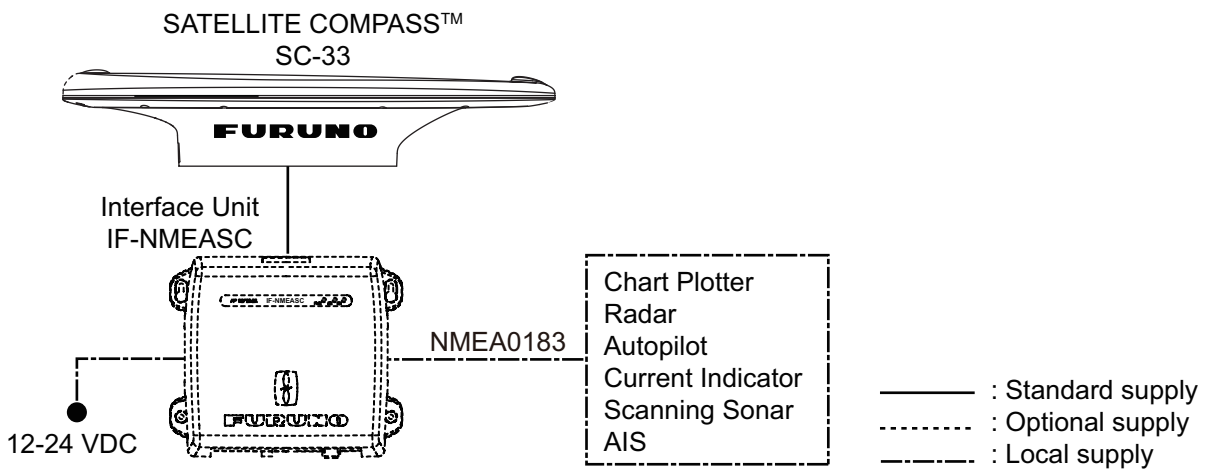

NMEA0183 connection with the IF-NMEA2K2

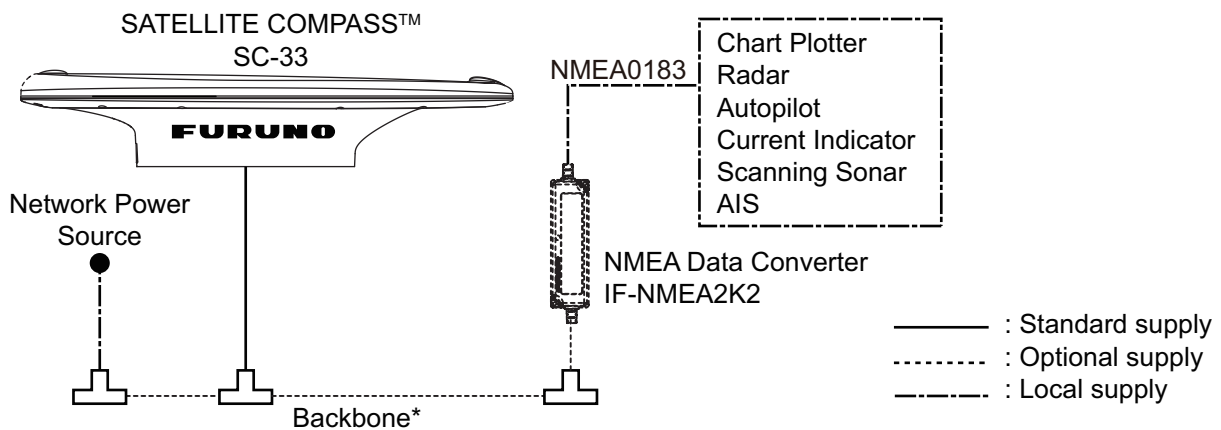

*: Termination resistors must be installed at both ends of the backbone.

1. MOUNTING

1.1 Equipment Lists

Standard supply

Name	Type	Code No.	Qty	Remarks
SATELLITE COMPASS™	SC-33	-	1	
Installation Materials	CP20-04400	000-035-094	1 (Select)	For NavNet Series, etc., With cable FRU-NMEA-PMMFF-060 (6 m) and Installation materials CP20-04401
	CP20-04410	000-035-095		For connecting IN-NMEASC, With cable FRU-NMEA-NFF-R15 (15 m) and Installation materials CP20-04401
	CP20-04401	001-508-130		No cable

* See packing list at back of manual for details.

1. MOUNTING

Optional supply

Name	Type	Code No.	Remarks
Interface Unit	IF-NMEASC	-	See OME-72651-x attached to the Interface Unit.
NMEA Data Converter	IF-NMEA2K2	-	
Cable Assembly	FRU-NMEA-NFF-R15	001-507-080	For IF-NMEASC, 15m, φ6.7
	FRU-NMEA-NFF-R30	001-507-090	For IF-NMEASC, 30m, φ6.7
Cable Conversion kit	OP20-50	001-506-810	Replacement kit for SC-30 ?(MJ-A10SPF0015-xxxC) Contents - Waterproof relay box (JPBS 06) - 120 Ω Lead resistance ?(03S9939) - FRU-NMEA-PFF-060 - Vinyl tape (0.2X19X10000MM Black, 000-172-691-10) - Self-bonding tape (No.15, 000-174-646-10)
Bird-Repellent Fixture	OP20-36	004-380-830	Four pieces
	OP20-37	004-380-840	Single
Cable for NMEA2000 (Micro)	FRU-NMEA-PMMFF-010	001-506-820	w/connectors (Light), 1m
	FRU-NMEA-PMMFF-020	001-506-830	w/connectors (Light), 2m
	FRU-NMEA-PMMFF-060	001-507-000	w/connectors (Light), 6m
	FRU-NMEA-PFF-010	001-507-010	w/connector (Light), 1m
	FRU-NMEA-PFF-020	001-507-030	w/connector (Light), 2m
	FRU-NMEA-PFF-060	001-507-040	w/connector (Light), 6m
Connector for NMEA2000	FRU-MM1MF1MF1001	001-507-050	T-Connector, Micro Style: 3
	FRU-MF000000001	001-507-060	Micro Style, female, termination resistor
	FRU-MM100000001	001-507-070	Micro Style, male, termination resistor

1.2 Mounting Considerations

In addition to the considerations described in this section, keep the length of the SC-33 cable in mind when selecting a mounting location.

General considerations

Mount the SC-33 above radar mast

As shown in the figure below, mount the SC-33 above a radar mast. This provides an unobstructed path between the SC-33 and the satellite, regardless of vessel heading. Follow the procedure on the next page to choose an installation site.

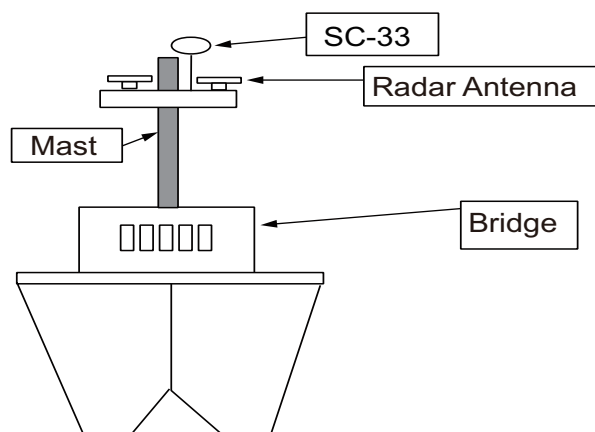

SC-33 mounted above antennas and structures

If SC-33 cannot be installed above radar mast

If absolutely impossible to do otherwise, the SC-33 may be installed below a radar mast. However, certain guidelines must be followed to prevent the shading and multipath problems which occur as shown in the figure below. Follow the procedure on the next page to choose an installation site.

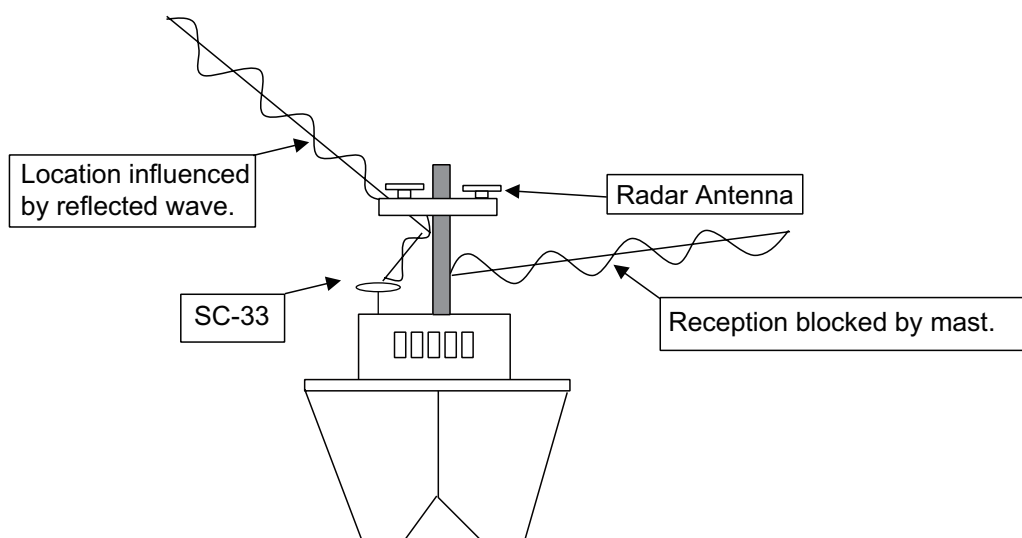

Problems associated with mounting SC-33 below a radar mast

1. MOUNTING

Selecting the installation site

The installation site must satisfy the four conditions described in this section. After choosing the site, determine installation height, following the procedure in the next section.

CONDITION 1: Locate the SC-33 away from masts that might prevent reception of the GNSS signal

- Install the SC-33 where the field of view against zenith is at least $\pm 85^\circ$. The installation site should be as high as possible, above masts, etc. which might interfere with reception.

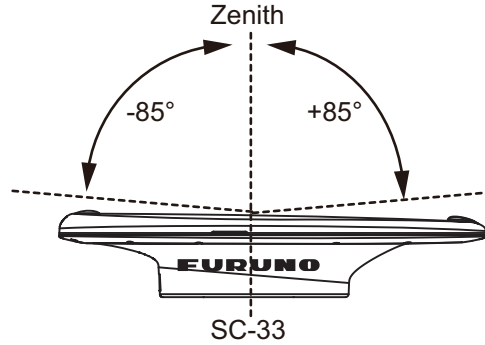

- If the above condition cannot be satisfied, separate the SC-33 so that the horizontal angle to the interfering object is less than 10° . Refer to the table below to determine minimum separation distance.

Mast diameter	Min. separation distance
10 cm	1.5 m
30 cm	3 m

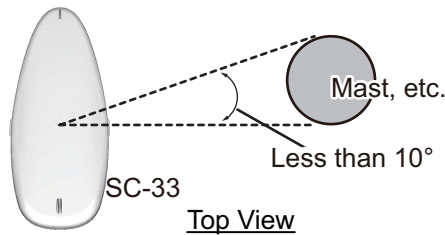

CONDITION 2: Locate the SC-33 out of radar beams

- Locate the SC-33 more than 20° above the top of a radar antenna.
- Separate the SC-33 at least 3 m from an open-type radar antenna.
- If the SC-33 cannot be separated at least 3 meter from an open-type radar antenna, install it at least 80 cm above the top of the radar antenna.

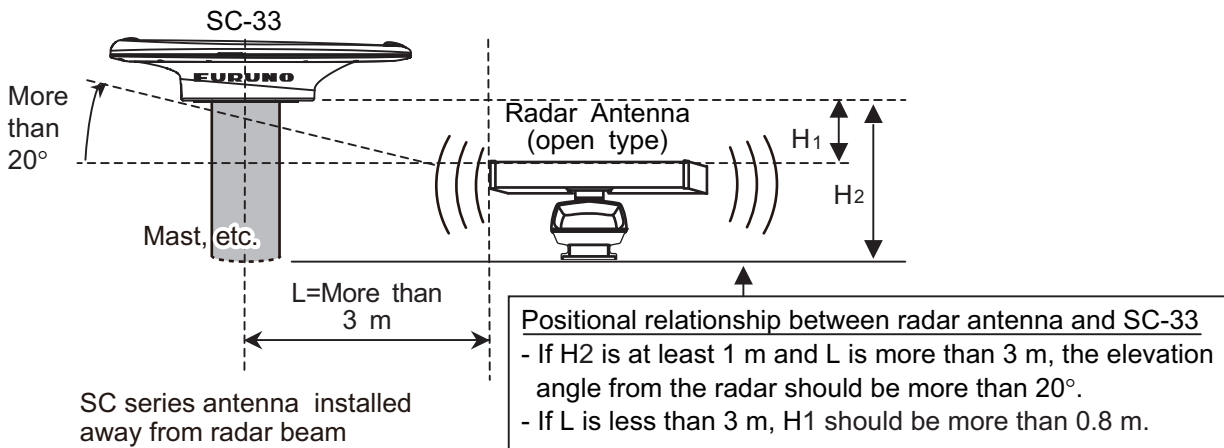

SC series antenna installed away from radar beam

Separation distances from radar antenna

CONDITION 3: Locate the SC-33 out of Inmarsat

Separate the SC-33 from an Inmarsat Fleet Broadband Antenna by at least 3 m.

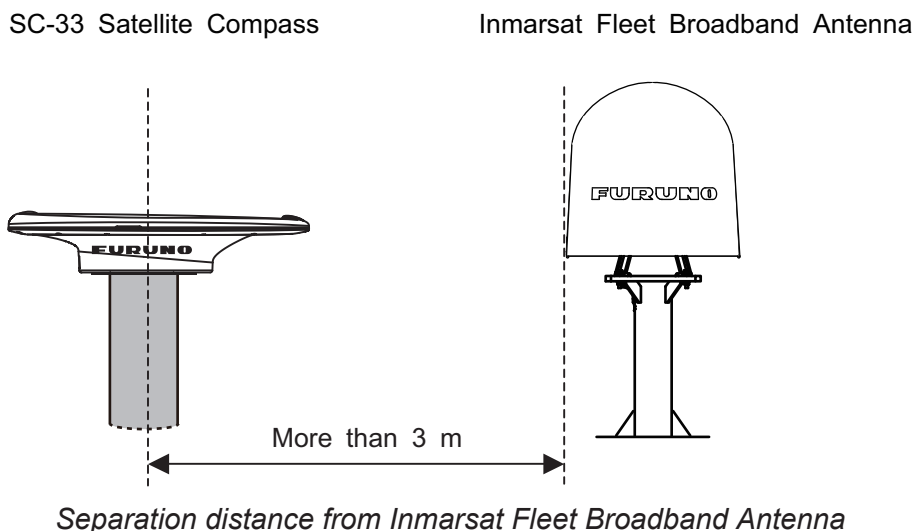

CONDITION 4: Locate the SC-33 away from communication (VHF, etc.) antennas

Separate the SC-33 as far as possible from communication antennas.

CONDITION 5: Select a stable location with minimal or no vibrations from engines or waves

Install the SC-33 in a stable location. The SC-33 contains highly sensitive GNSS and angular speed sensors. Therefore, try to install it where shock, vibration, etc. are minimal.

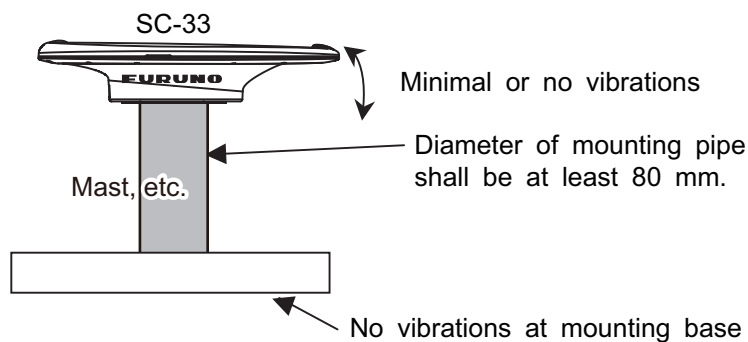

1. MOUNTING

Installation height

After choosing the installation site, determine the installation height, considering composition of the deck and surrounding area.

The deck is flat and metallic, or the area around the installation site is metallic

- If metallic surface is wider than the area of the top view of the SC-33, install the SC-33 at least 800 mm above the deck.

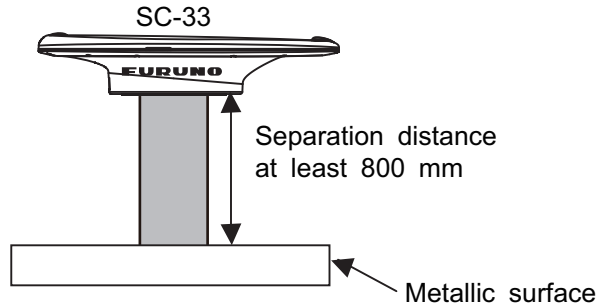

The deck is non-metallic (FRP, etc.) and there are no metallic objects around the installation site

- If mounting surface is non-metallic and there is no radar or Inmarsat antenna in the vicinity, mount the SC-33 directly on the non-metallic surface. This can be done provided the metallic material support is smaller than the SC-33. If the SC-33 is to be fixed to a mounting pipe, choose a site where there is less vibration.

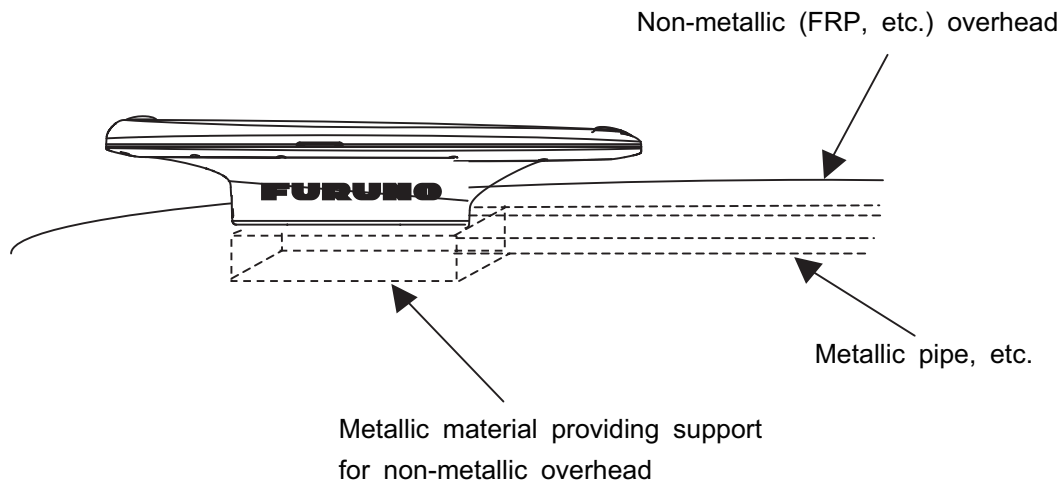

Installation examples for a pleasure boat

No tuna tower

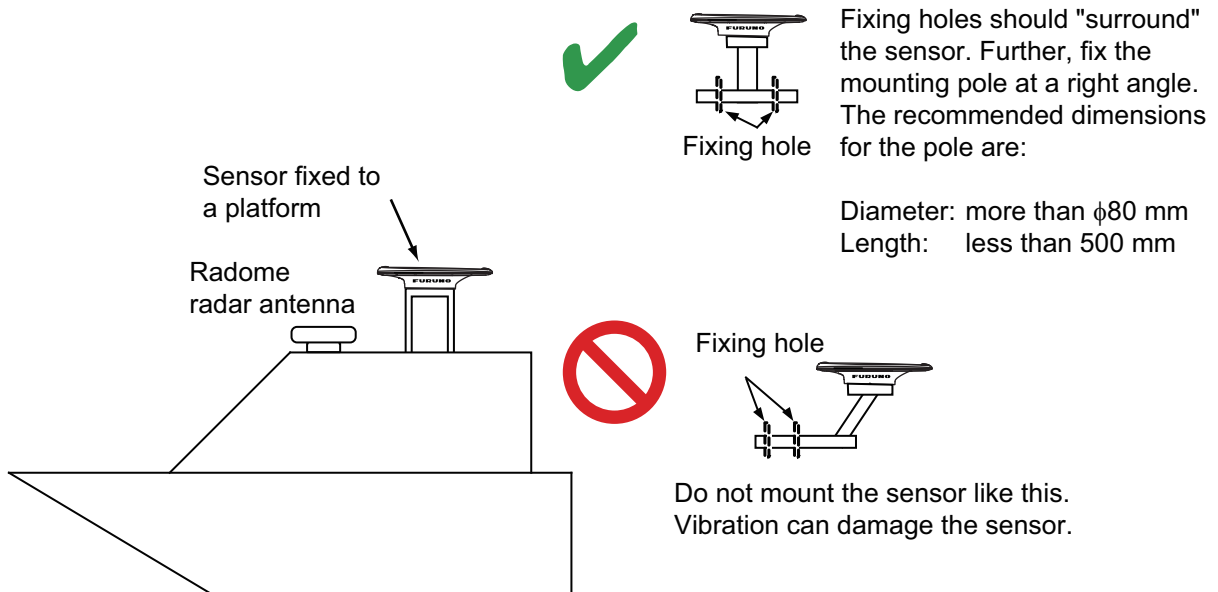

With tuna tower

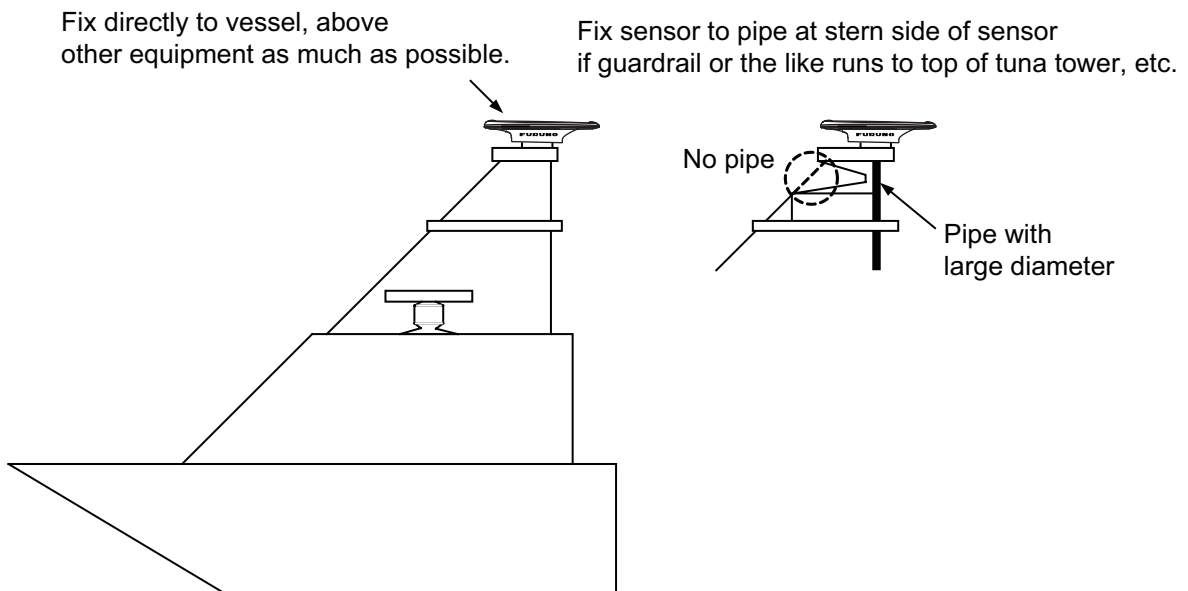

1. MOUNTING

1.3 Mounting Procedure

Note 1: The bird-repellent fixtures (optional supply) can be attached to the antenna cover to prevent birds from landing on the cover. If it is more convenient to attach the bird-repellent fixtures before securing the antenna unit to the mounting location, do step 6 below before fixing the antenna unit.

Note 2: According to the installation location, connecting the antenna pig tail connector to the NMEA2000 bus or a cable from an optional unit in advance is easy to fix to the location. Connect a cable with reference to step 5 beforehand. Then, waterproof the connection.

1. As shown in the figure below, weld a platform (local supply) for which to mount the SC-33. The thickness of the platform should be 5 mm to 15 mm.

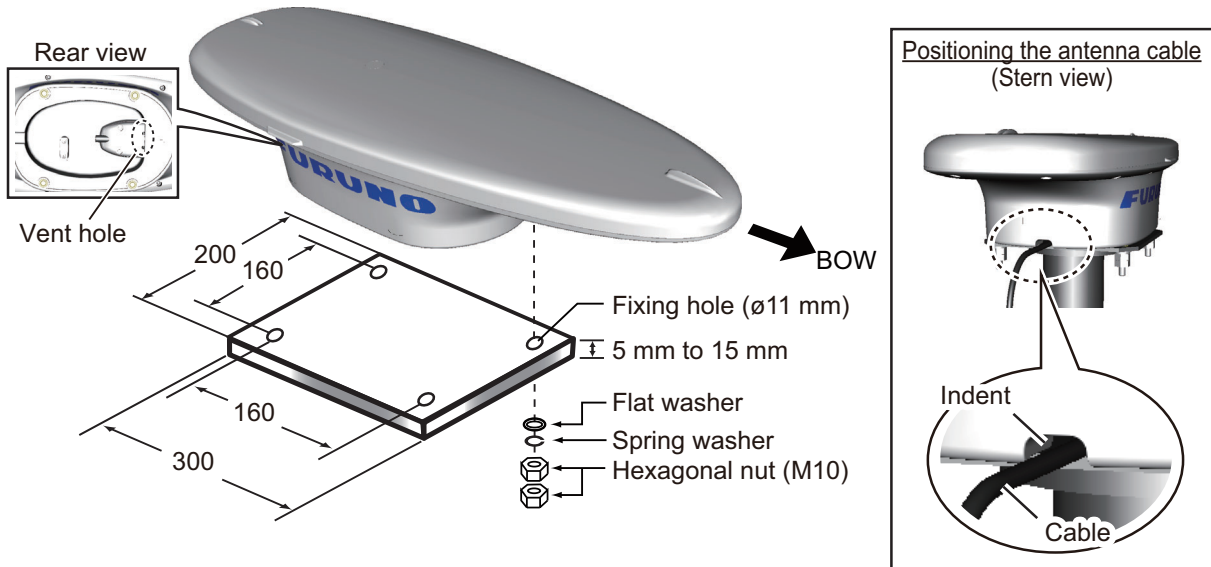

2. Orient the antenna unit to face the bow, referring to the figure above. The antenna should be installed within $\pm 2.5^\circ$ of the bowline.

Note 1: Take care not to crush the cabling when mounting the antenna to the platform.

Note 2: Take care not to cover the vent hole on the antenna.

3. Secure the unit to the platform with four sets of M10 hex. nuts, spring washers and flat washers (all included as installation materials) with 20 ± 2 N•m torque.

How to fasten double nuts

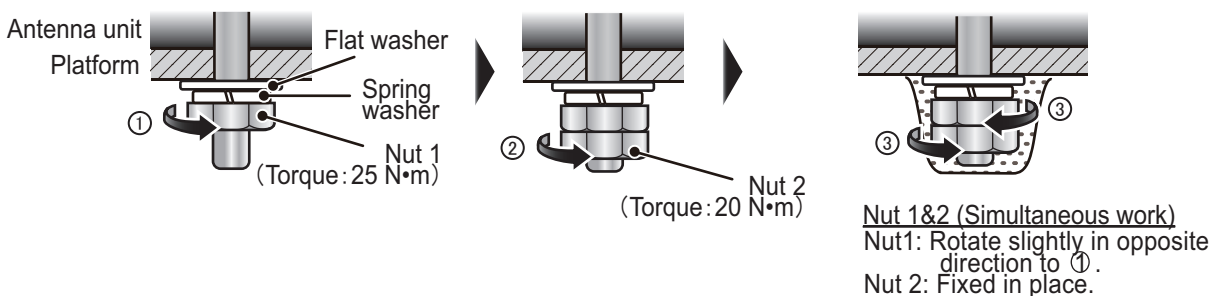

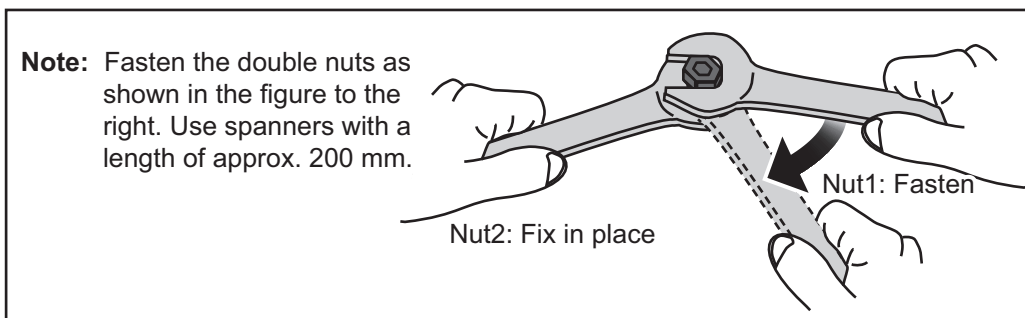

4. Coat the exposed parts of the nuts, bolts and washers with the Adhesive TB5211 (included) to prevent corrosion.

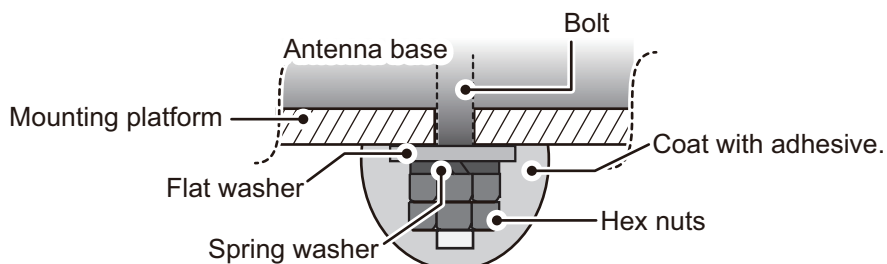

5. Connect the antenna pig tale connector to the NMEA2000 bus or a cable from the optional unit, then waterproof the connection. See chapter 2 for the wiring and the waterproofing.
6. Remove the double-sided tape from the optional bird-repellent fixtures, then attach to the antenna cover. Coat around the bird-repellent fixtures with the Adhesive TB5211 (included).



7. Fix the SC-33 cable to the pipe at suitable intervals with the cable ties (local supply).
Note: Create a loop in the cable close to the SC-33 and tie the loop with a cable tie for maintenance work, as shown in the below figure.

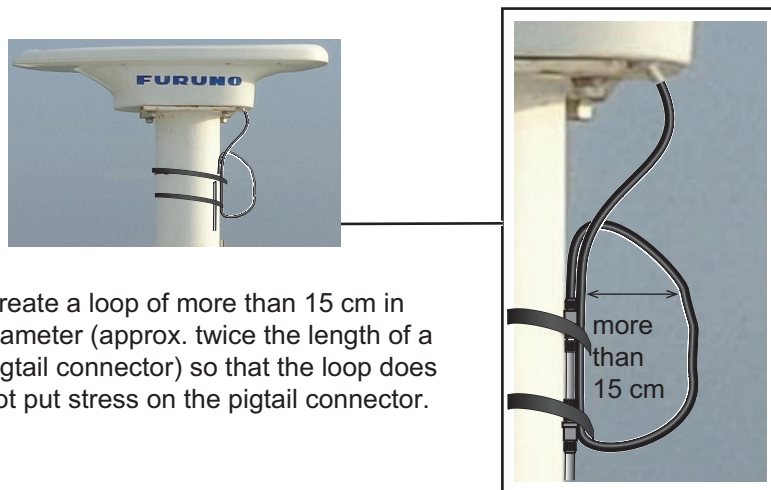

2. WIRING

Attention

- Do not loop the antenna cable.
- Do not bundle the SC-33 cable with radio equipment cables.
- When the above noise reductions are insufficient, adjust the squelch on the radio equipment.

2.1 NMEA 2000 Network Connection

Using the supplied cable assembly, connect the SC-33 cable (Micro style connector) to the NMEA2000 network backbone.

The SC-33 connects to the devices in an NMEA 2000 network with a drop cable, which is connected to a backbone cable w/T-type connectors. The backbone cable can be light or heavy type. Attach a terminator at both ends of the backbone cable. Use a Micro-C connector to connect to the devices. We recommended that power from the NMEA 2000 network be input at the center of the backbone cable. For connection to the IF-NMEA SC Interface Unit, see its operator's manual.

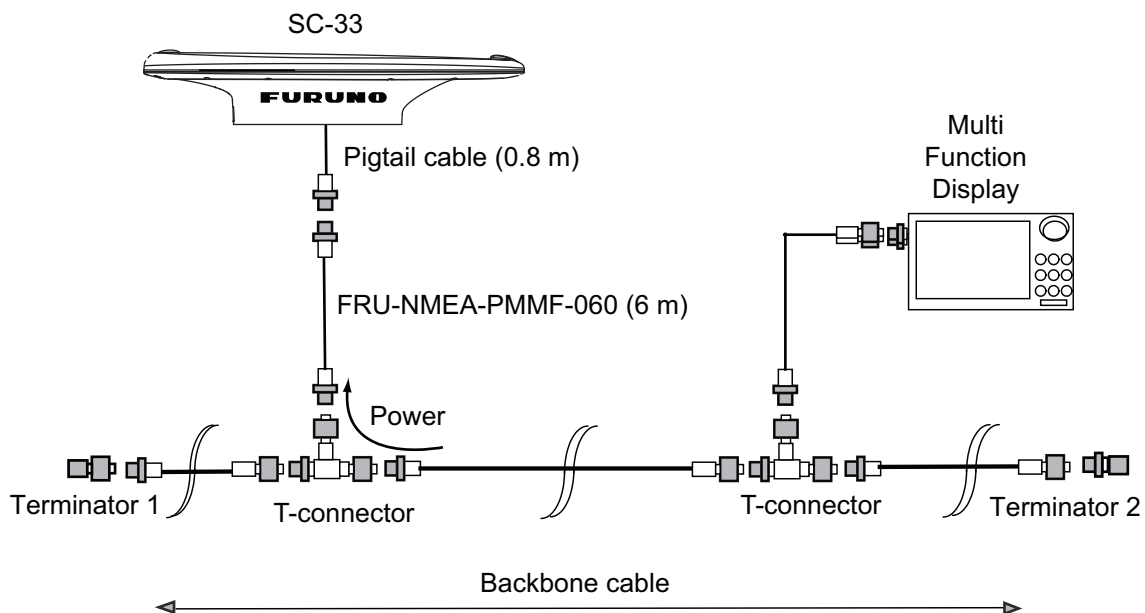

What is NMEA 2000 (CAN) bus?

CAN bus is a communication protocol (NMEA2000 compliant) that shares multiple data and signals through a single backbone cable. You can simply connect any CAN bus devices onto the backbone cable to expand your network on-board. With CAN bus, IDs are assigned to all the devices in the network, and the status of each sensor in the network can be detected. All the CAN bus devices can be incorporated into the CAN bus network. For detailed information about CAN bus wiring, see "Furuno CAN bus Network Design Guide" (Type: TIE-00170) on Tech-Net.

Guideline for Connecting

Follow these guidelines when selecting a mounting location.

- Where the cable connectors and CAN bus/NMEA2000 connectors are subjected to moisture or water spray, waterproof the connectors as shown below.
 1. Wrap the connection point with a single layer of vinyl tape.
 2. Wrap one layer of self-bonding tape over the vinyl tape.
 3. Wrap two layers of vinyl tape over the self-bonding tape.

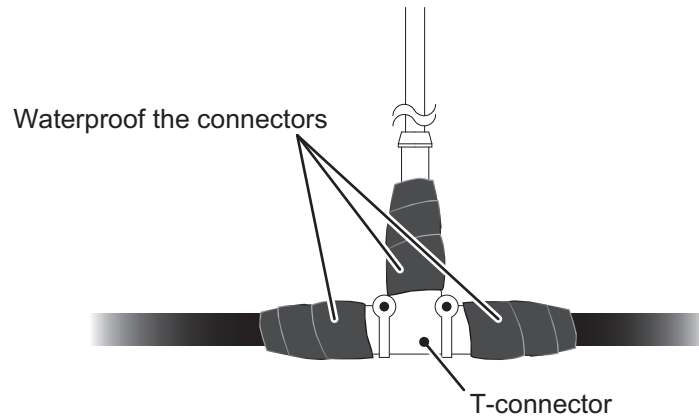

2.2 NMEA 0183 Network Connection

Optional interface unit IF-NMEASC is required when connecting with NMEA0183 equipment. For IF-NMEASC, see the Operator's Manual of the IF-NMEASC.

2.2.1 How to connect the Cable Assembly (FRU-NMEA-NFF-R15/30)

The installation of the other terminal connector and T-connector is not required because the FRU-NMEA-NFF-R15/30 is the terminal resistance internal cable of 120 ohm.

Securing and waterproofing connections

- Where the cable connectors and CAN bus/NMEA2000 connectors are subjected to moisture or water spray, waterproof the connectors as shown below.
 1. Wrap the connection point with a single layer of vinyl tape.
 2. Wrap one layer of self-bonding tape over the vinyl tape.
 3. Wrap two layers of vinyl tape over the self-bonding tape.

STEP 1

Wrap connection in self-bonding tape for waterproofing.

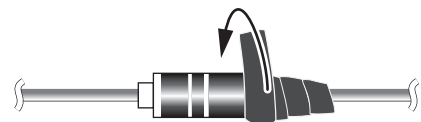

STEP 2

Wrap the self-bonding tape with vinyl tape, covering approx. 50 mm of the connecting cable.

Bind the tape ends with cable cable ties to prevent the tape from unraveling.



2. WIRING

2.2.2 How to connect the Cable Replacement Kit (OP20-50)

Use a waterproof relay box (JPBS06) to relay connection when connecting to the SC-33 with the MJ-A10SPF0015-150C/300C cable used in SC-30.

- 1) Unfasten four washer head screws on the top of the waterproof relay box to remove the cover.



- 2) Fabricate the MJ-A10SPF0015-150C/300C as follows.

- 1) Cut the MJ-10 connector part. Expose inner vinyl sheath by approx. 40 mm. Be careful not to damage inner shield and cores.

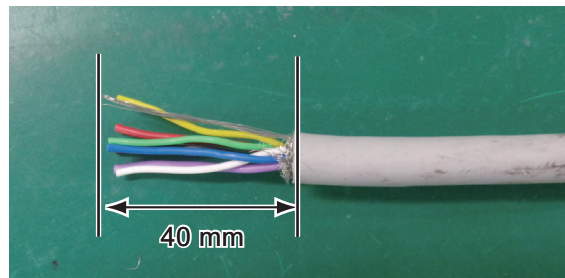

- 2) Cut unused wires (green, yellow and purple) to approx. 10 mm, then isolate them with vinyl tape. Wrap the drain wire with a vinyl tube. Wrap the drain wires with the vinyl tube.

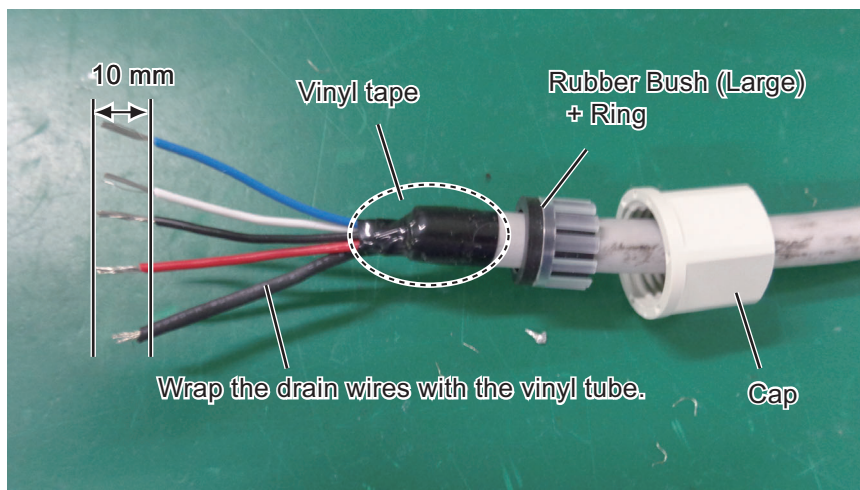

Note: Make sure the rubber bush and ring are oriented correctly (as shown in the figure above).

3) Fabricate the FRU-NMEA-PFF-060 cable as follows.

- 1) On the end of the side without the FRU connector, cut into the one end part of the FRU connector. Expose inner vinyl sheath by approx. 40 mm. Be careful not to damage inner shield and cores.

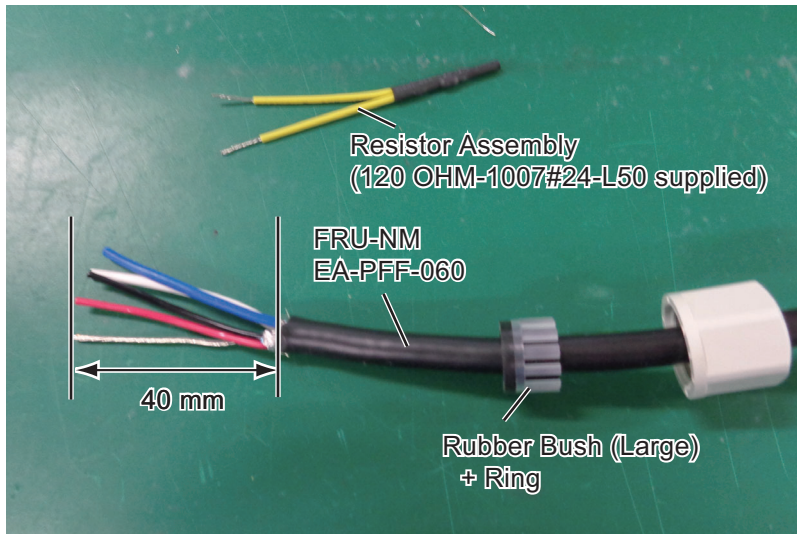

- 2) Wrap the drain wire with a vinyl tube.

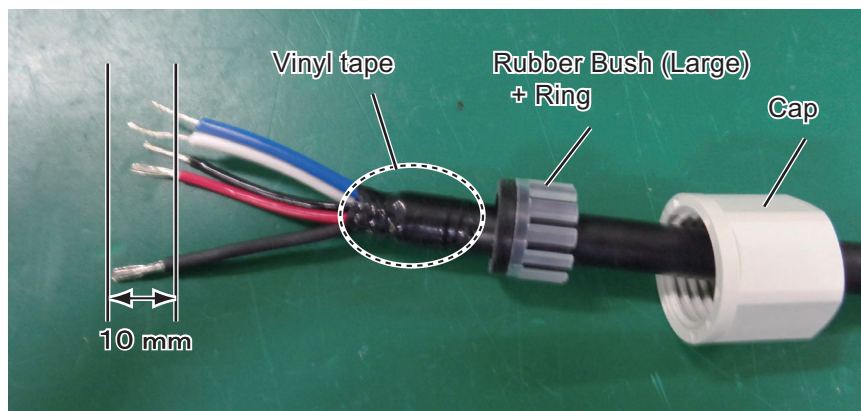

Note: Make sure the rubber bush and ring are oriented correctly (as shown in the figure above).

- 3) Twist the blue and white core wires and a resistor assembly, and attach a closed-end lug to the wires.

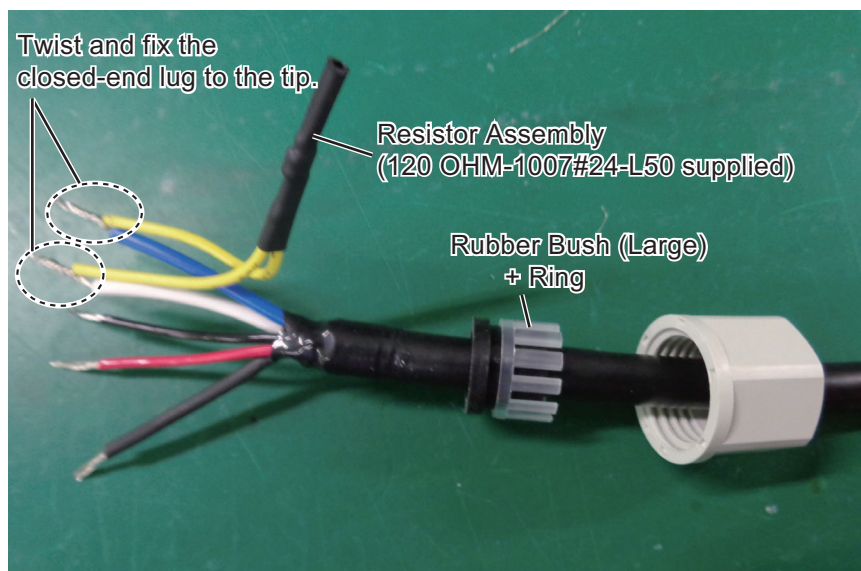

2. WIRING

- 4) Connect the cables to the waterproof relay box.
Connect the CAN cable (FRU-NMEA-PFF-060) included to the cable replacement kit and the cable for SC-30 (MJ-A10SPF0015-150C/300C) to the internal terminal box.

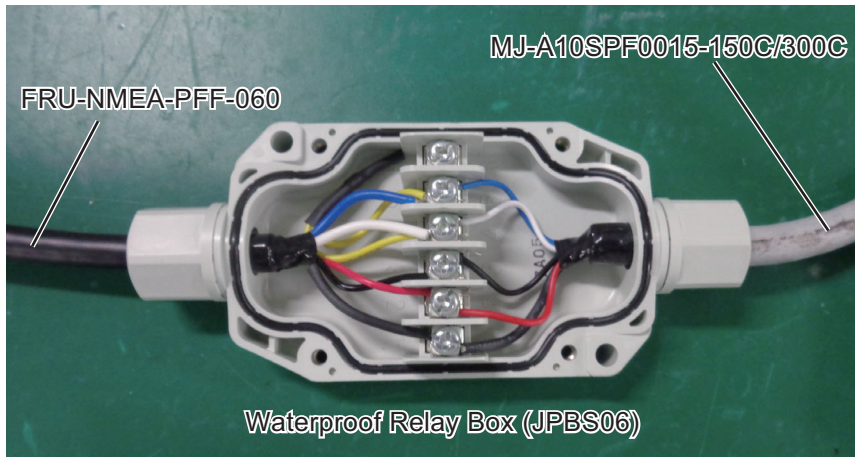

- 5) Fit the rubber bush, ring and cap, in that order. Make sure the order is as shown in the below figure, to keep the IP rating.

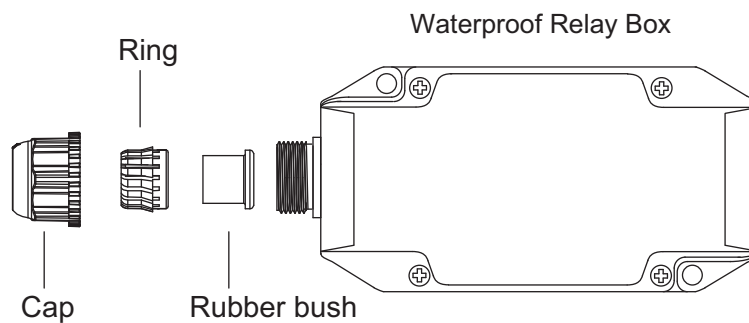

- 6) Fit the cover to the waterproof relay box, then secure the cover with the four washer screws removed at step 1.



2.2.3 How to secure and waterproof the cable connections

Cable connection for the waterproof relay box, whether exposed to weather or otherwise, should be waterproofed and secured after making the connection.



- 1) Wrap the cap with several layers of self-bonding tape (supplied), to reduce the height difference between the cap and the box.



- 2) Starting at approximately 40 mm from the both caps, wrap the cap and waterproof relay box with three layers of self-bonding tape.

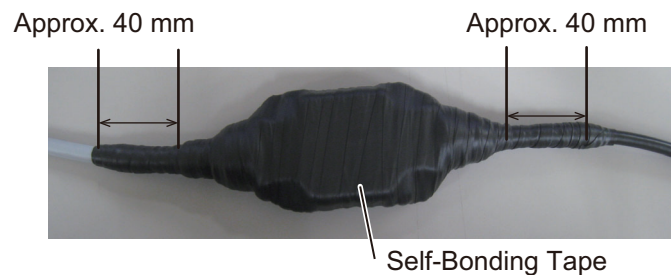

Note: Take care that the self-bonding tape is not cut on the waterproof relay box or cap edges.

- 3) Wrap two layers of vinyl tape, in opposite direction, to cover the self-bonding tape.



3. ADJUSTMENTS

When the unit is powered, it is in a “cold start” state. There is no satellite data (almanac data) stored. In this state, the unit searches for, and stores, satellites to find its heading. This process takes approximately 90 seconds. If the heading is not found within 30 minutes, the antenna installation location may not be suitable. Ensure an unobstructed path between the SC-33 and satellites. Once a heading has been found, initial settings should be done.

If the heading error is 5° or higher, adjust the antenna unit orientation while monitoring the heading indication.

Initial settings can be done via the NMEA2000 network with one of the following methods:

- Access the setting menu of the SC-33 from compatible equipment.
 - TZTL12F/TZTL15F/TZT2BB: Software version must be “06.01” or later.
 - NAVpilot-300: Software version of the control unit must be “01.07” or later, and software version of the processor unit must be “01.06” or later.

See the operator’s manual of the equipment used to access the SC-33 for how to access the setting menu.

- Connect a PC and setup the SC-33 using the SC setting tool.
You can download the SC setting tool from the quick response code to the right. For how to use the SC setting tool, see the operator’s manual provided with the SC setting tool (OME-72851).



Note 1: If the SC-33 is re-booted, re-connection is required to access the SC-33 menu.

Note 2: This manual provides descriptions for the SC-33 setting menu that you can access from the compatible equipment. See the "MENU TREE" on page AP-1 for menu details. For how to use the SC setting tool, see the operator’s manual provided with the SC setting tool (OME-72851).

3.1 [GNSS Setup] Menu

You can disable (ignore) satellites and adjust the elevation mask from the [GNSS Setup] menu.

Menu item	Description
Disable SV	
QZSS All	Select [YES] to ignore all satellites of the QZSS system.
QZSS1	You can ignore satellites of the QZSS system by specifying the satellite number. A maximum of three satellites can be registered to be ignored. Note: When [QZSS All] is set to [YES], the setting values for [QZSS1] to [QZSS3] are automatically changed to “0”.
QZSS2	
QZSS3	
GPS All	Select [YES] to ignore all satellites of the GPS system.
GPS1	You can ignore satellites of the GPS system by specifying the satellite number. A maximum of three satellites can be registered to be ignored. Note: When [GPS All] is set to [YES], the setting values for [GPS1] to [GPS3] are automatically changed to “0”.
GPS2	
GPS3	
GLONASS All	Select [YES] to ignore all satellites of the GLONASS system.

Menu item		Description
GLONASS1		You can ignore satellites of the GLONASS system by specifying the satellite number. A maximum of three satellites can be registered to be ignored. Note: When [GLONASS All] is set to [YES], the setting values for [GLONASS1] to [GLONASS3] are automatically changed to "0".
GLONASS2		
GLONASS3		
Galileo All		Select [YES] to ignore all satellites of the Galileo system.
Galileo1		You can ignore satellites of the Galileo system by specifying the satellite number. A maximum of three satellites can be registered to be ignored. Note: When [Galileo All] is set to [YES], the setting values for [Galileo1] to [Galileo3] are automatically changed to "0".
Galileo2		
Galileo3		
SV ELEV		
SV ELEV		Adjust the elevation mask angle. This equipment does not track satellites with an elevation angle lower than the angle set here. A higher elevation mask angle increase the positioning accuracy, but the number of the available satellites may be decreased and equipment may not be able to obtain an accurate position fix
SBAS		
SBAS Mode		Enable/disable correction from SBAS (Satellite-based Augmentation System). • [On]: Enable correction from SBAS. • [Off]: Disable correction from SBAS.
SBAS Search		Select [Auto] to search automatically for SBAS satellites, or [Manual] to manually input the SBAS satellite number.
SBAS Satellite Selection		Manually input the SBAS satellite number(s) you want to use. Note 1: This item is only available when [SBAS Search] is set to [Manual]. Note 2: A satellite number entered at [Disable SBAS] will be rejected.
Disable SBAS	SBAS All	Select [YES] to ignore all SBAS satellites.
	SBAS 1	You can ignore SBAS satellites by specifying the satellite number. A maximum of three satellites can be registered to be ignored. Note: When [SBAS All] is set to [YES], the setting values for [SBAS 1] to [SBAS 3] are automatically changed to "0".
	SBAS 2	
	SBAS 3	
QZSS		
ON/OFF		Enable/disable the use of the QZSS system. Reboot the SC-33 to apply the setting.

3.2 [Sensor] Menu

Enter the ship's information and installation location of the SC-33 and adjust the sensor offset values on the [Sensor] menu.

Menu item	Description
Offset	
HDG	Offset the heading angle. When the heading angle is skewed right, enter a negative value. When the heading angle is skewed left, enter a positive value.
Pitch	Offset the roll angle.
Roll	Offset the pitch angle.
Air Pressure	Offset the air pressure value.

3. ADJUSTMENTS

Menu item	Description
Air Temperature	Offset the air temperature value. Note: The displayed temperature appears lower than the actual temperature immediately after the power is turned on. It takes approximately one hour for the equipment to display the correct temperature in a stable manner.
Smoothing	
ROT	Set the time delay (smoothing) for ROT data output. Normally, keep the default setting. If you want to improve the response performance of ROT data, enter the lower value than the default setting (2.0 sec).
DR Time	
DR Time	When the SC-33 cannot receive the signal from the satellite, the SC-33 keeps outputting the heading data to use dead reckoning for the time set here. If the signal from the satellite cannot be retrieved with in the time set here, the SC-33 stops outputting the heading data.
Ship Size, ANT Position	
<p>Enter the appropriate value according to the ship's size, to improve the accuracy of the 3-axis speed. The reference position for mounting position and calculating position of the 3-axis speed are shown in the following figure:</p>	
Ship's Width	Set the ship's width, calculated from the port-side to starboard-side of the widest section of the vessel.
Ship's Length	Set the ship's length, calculated to the bow-tip to the stern, along the center of the vessel.
Ship's Height	Set the ship's height, calculated to the bottom of the keel to the top of the mast.
ANT Position X0	Set the port-starboard (Lateral) position of the SC-33. Enter negative value for port-side, positive value for starboard-side. The center of the vessel is "0".
ANT Position Y0	Set the bow-stern (Longitudinal) position of the SC-33. Set the distance from the bow to the stern with the bow as 0 m.
ANT Position Z0	Set height of the SC-33, from the bottom of the ship.
CALN-SPD-POSN Y1 (Bow)	Set the bow-stern position for calculating the 3-axis speed. Ship's speed can be measured at two locations in addition to the antenna position. Enter the backward distance from the reference position (Fwd Center of the bow) to the position where you want to measure the ship's speed. Normally, enter the bow position (Y1) and stern position (Y2). Note: In the default setting, Y1 and Y2 are entered as follows: <ul style="list-style-type: none"> • Y1: 0 m (bow position) • Y2: 20 m (20 m backward from bow position)
CALN-SPD-POSN Y2 (Stern)	

Menu item	Description
CALN-SPD-POSN Z (Height)	Set the height for calculating the 3-axis speed. Enter the distance from the bottom of the ship to the position where you want to measure the ship's speed. For example, enter the draft value when you want to measure the speed at draft position.

3.3 [Input/Output] Menu

You can enable/disable PGN output from the SC-33 and adjust transmission rate on the [Input/Output] menu.

The following table shows the PGNs that the SC-33 outputs and transmission rate is adjustable. If you want to disable the PGN, set the transmission rate to "0 msec". The setting range changes according to the PGN. For the setting range of each PGN, see "MENU TREE" on page AP-1.

Note: Normally, keep the default setting. If there is a need to change the transmission rate, only change the rate for necessary PGNs. An excessive number of PGNs with a low transmission rate can cause problems with PGN output and transmission rates.

PGN	PGN name
065280	Heave
126992	System Time
126993	Heartbeat
127250	Vessel Heading
127251	Rate of Turn
127252	Heave
127257	Attitude
127258	Magnetic Variation
129025	Position, Rapid Update
129026	COG and SOG, Rapid Update
129029	GNSS Position Data
129033	Time and Date
129539	GNSS DOPs
129540	GNSS Sats in View
130310	Environmental Parameters
130312	Temperature
130314	Actual Pressure
130316	Temperature, Extended Range
130577	Direction Data
130578	Vessel Speed Components
130820	Motion Sensor Status
130826	Multi Sats In View
130842	Six Degrees of Freedom Movement
130843	Heel Angle and Roll Information
130845	Multi Sats In View Extended
130846	Motion Sensor Status Extended

3.4 [System] Menu

You can check the system information, perform the diagnostic test and restore the factory default from the [System] menu.

Menu item	Description
System Information	
Main PCB	Version of the Main board.
Sub IMU PCB	Version of the SUB IMU board. When the SUB IMU board is not installed, "- -" appears.
MAIN CPU OS Version	OS version.
MAIN CPU Application Version	SC-33 software version.
WMM	Software version of the WMM (World Magnetic Model).
GNSS1	Version of the GNSS core 1 to 3.
GNSS2	
GNSS3	
CAN Unique Number	CAN unique ID of the SC-33.
Main Overall Powered Time	Total operation time of the Main board.
Sub IMU Runtime	Total operation time of the SUB IMU board. When the SUB IMU board is not installed, "- -" appears.
Antenna1 Powered Time	Total operating time of the antenna 1 and 2.
Antenna2 Powered Time	
Model	Product model name (SC-33).
Simple Diagnostic Test	
Simple Diagnostic	Select [START] to perform the diagnostic test.
ROM	ROM test result (OK or NG).
Internal RAM	Internal RAM test result (OK or NG)
GNSS1 ROM	ROM and RAM check results for GNSS1 to 3 (OK or NG).
GNSS1 RAM	
GNSS2 ROM	
GNSS2 RAM	
GNSS3 ROM	
GNSS3 RAM	
CAN	CAN check result (OK or NG).
Main Accelerometer Status X	Test result for the acceleration sensor on the MAIN board (OK or NG). X-axis, Y-axis and Z-axis test results are shown. When the SUB IMU board is installed, check result indicates ""- -".
Main Accelerometer Status Y	
Main Accelerometer Status Z	
Main Rate Gyro Status X	Test result for the gyro sensor on the MAIN board (OK or NG). X-axis, Y-axis and Z-axis test results are shown. When the SUB IMU board is installed, check result indicates ""- -".
Main Rate Gyro Status Y	
Main Rate Gyro Status Z	
Main Magnetic Sensor Status	Test result for the magnetic sensor on the MAIN board (OK or NG). When the SUB IMU board is installed, check result indicates ""- -".
Main Pressure Sensor Status	Test result for the air pressure sensor on the MAIN board (OK or NG). When the SUB IMU board is installed, check result indicates ""- -".
Sub IMU Accelerometer Status X	Test result for the acceleration sensor on the SUB IMU board (OK or NG). X-axis, Y-axis and Z-axis test results are shown. When the SUB IMU board is not installed, check result indicates ""- -".
Sub IMU Accelerometer Status Y	
Sub IMU Accelerometer Status Z	

Menu item	Description
Sub IMU Rate Gyro Status X	Test result for the gyro sensor on the SUB IMU board (OK or NG). X-axis, Y-axis and Z-axis test results are shown. When the SUB IMU board is not installed, check result indicates "'- -'".
Sub IMU Rate Gyro Status Y	
Sub IMU Rate Gyro Status Z	
Sub IMU Magnetic Sensor Status	Test result for the magnetic sensor on the SUB IMU board (OK or NG). When the SUB IMU board is not installed, check result indicates "'- -'".
Sub IMU Pressure Sensor Status	Test result for the air pressure sensor on the SUB IMU board (OK or NG). When the SUB IMU board is not installed, check result indicates "'- -'".
Antenna1 Test	Antenna1 and 2 test result.
Antenna2 Test	
Reset Setting	
GNSS	Select [YES] to restore the factory default settings for the [GNSS Setup] menu. Reboot the SC-33 to apply the setting.
Menu Settings	Select [YES] to restore the factory default settings for the following menus: <ul style="list-style-type: none"> • [GNSS Setup] menu • [DR Time] menu • [Offline] menu Reboot the SC-33 to apply the setting.
Factory Reset	Select [YES] to restore the factory default settings for all menus excludes the following menus. <ul style="list-style-type: none"> • [Offset] menu • [Ship Size, ANT Position] menu Reboot the SC-33 to apply the setting.
Performance	
CPU	Show the CPU usage.
Memory	Show the memory usage.
Offline	
Offline	This menu item is prepared for the service person. Normally, keep the default setting ([OFF]).

3.5 [Advanced Sensor Setting] Menu

You can check and adjust the gain and offset setting of the sensor on the MAIN and SUB IMU boards from the [Advanced Sensor Setting] menu. The gain and offset settings for the sensor on the MAIN board cannot be adjusted.

Menu item	Description
Rate Gyro	
Main X Percent	Shows the gain setting of the gyro sensor on the MAIN board. The setting values for X-axis, Y-axis and Z-axis are shown.
Main Y Percent	
Main Z Percent	
Main X Offset	Shows the offset setting of the gyro sensor on the MAIN board. The setting values for X-axis, Y-axis and Z-axis are shown.
Main Y Offset	
Main Z Offset	
Sub IMU X Percent*	Adjusts the gain setting of the gyro sensor on the SUB IMU board. The setting values for X-axis, Y-axis and Z-axis can be adjustable.
Sub IMU Y Percent*	
Sub IMU Z Percent*	

3. ADJUSTMENTS

Menu item	Description
Sub IMU X Offset*	Adjusts the offset setting of the gyro sensor on the SUB IMU board. The setting values for X-axis, Y-axis and Z-axis can be adjustable.
Sub IMU Y Offset*	
Sub IMU Z Offset*	
Accelerometer	
Main X Percent	Shows the gain setting of the acceleration sensor on the MAIN board. The setting values for X-axis, Y-axis and Z-axis are shown.
Main Y Percent	
Main Z Percent	
Main X Offset	Shows the offset setting of the acceleration sensor on the MAIN board. The setting values for X-axis, Y-axis and Z-axis are shown.
Main Y Offset	
Main Z Offset	
Sub IMU X Percent*	Adjusts the gain setting of the acceleration sensor on the SUB IMU board. The setting values for X-axis, Y-axis and Z-axis can be adjustable.
Sub IMU Y Percent*	
Sub IMU Z Percent*	
Sub IMU X Offset*	Adjusts the offset setting of the acceleration sensor on the SUB IMU board. The setting values for X-axis, Y-axis and Z-axis can be adjustable.
Sub IMU Y Offset*	
Sub IMU Z Offset*	
Magnetic	
Main X Percent	Shows the gain setting of the magnetic sensor on the MAIN board. The setting values for X-axis, Y-axis and Z-axis are shown.
Main Y Percent	
Main Z Percent	
Main X Offset	Shows the offset setting of the magnetic sensor on the MAIN board. The setting values for X-axis, Y-axis and Z-axis are shown.
Main Y Offset	
Main Z Offset	
Sub IMU X Percent*	Adjusts the gain setting of the magnetic sensor on the SUB IMU board. The setting values for X-axis, Y-axis and Z-axis can be adjustable.
Sub IMU Y Percent*	
Sub IMU Z Percent*	
Sub IMU X Offset*	Adjusts the offset setting of the magnetic sensor on the SUB IMU board. The setting values for X-axis, Y-axis and Z-axis can be adjustable.
Sub IMU Y Offset*	
Sub IMU Z Offset*	
Air Pressure	
Main Offset	Shows the offset setting of the air pressure sensor on the MAIN board.
Sub IMU Offset*	Shows the offset setting of the air pressure sensor on the SUB IMU board.
Air Temperature	
Main Offset	Shows the offset setting of the temperature sensor on the MAIN board.
Sub IMU Offset*	Shows the offset setting of the temperature sensor on the SUB IMU board.

*: The setting value is adjustable even if the SUB IMU board is not installed, but the setting value does not affect the SC-33 performance.

4. NMEA 2000 I/O DATA

The SC-33 handles the NMEA 2000 I/O data PGNs listed below. The LEN (Load Equivalency Number) is 11. (LEN is the amount of current a device draws from the NMEA 2000 network. 1 LEN = 50 mA.)

4.1 Input Data

PGN	Name	Remarks			
059392	ISO Acknowledgement				
059904	ISO Request	Request for PGN output of Note1 in the output data table on page 25.			
060160	ISO Transport Protocol, Data Transfer				
060416	ISO Transport Protocol, Connection Management - BAM Group Function	BAM = Broadband Announce Message			
060928	ISO Address Claim				
061184	Self Test Group Function				
065240	ISO Commanded Address				
126208	NMEA-Request Group Function	Request for PGN output of Note 1, 2 and 3 in the output data table on the page 25, also interval change for regular PGN output in the output data table on the next page.			
	NMEA-Command Group Function	Standard PGNs and their changeable fields			
		PGN	Name	Field	Name
		060928	ISO Address Claim	#3	Device Instance Lower
				#4	Device Instance Upper
				#8	System Instance
		126998	Configuration Information	#1	Installation Description, Field 1
				#2	Installation Description, Field 2
				#3	Installation Description, Field 3
		129538	GNSS Control Status	#1	SV Elevation Mask
#6	0 or 1 (Default 1) 0: SBAS OFF 1: SBAS ON				
126208	NMEA-Command Group Function	Other setting change is possible other than the above used Furuno proprietary PGN.			
		PGN	Name		
		126720	Variable Sensor Calibration Control Status		
		130817	FURUNO GNSS Control Status		
		130818	Heading & Attitude Sensor Control Status		
		130819	Motion Sensor Control Status		
		130833	Device Position and Ship Dimension Report		
130834	Position of Speed Measurement				
126720	GMM Message	Proprietary PGN			

4.2 Output Data

PGN	Name	Remarks	
059392	ISO Acknowledgement	-	Output for rejection of output request by ISO Request.
060928	ISO Address Claim	Note 1, 2	- Transmission at the time of address generation. - Output for receiving the output request by ISO Request.
061184	Self Test Group Function	-	- Proprietary PGN - Output for receiving the Self Test Group Function
065280	Heave	100 ms	- Proprietary PGN
126208	NMEA-Acknowledge Group Function	-	
126464	PGN List - Transmit PGN's Group Function	Note 1, 2	
	PGN List - Received PGN's Group Function	Note 1, 2	
126720	GMM Message	-	- Proprietary PGN - Output for GMM Message received.
	Variable Sensor Calibration Control Status	Note 2	- Proprietary PGN
126992	System Time	1000 ms	
126993	Heart Beat	60000 ms	
126996	Product Information	Note 1, 2	
126998	Configuration Information	Note 1, 2	
127250	Vessel Heading	100 ms	
127251	Rate of Turn	100 ms	
127252	Heave	100 ms	
127257	Attitude	100 ms	
127258	Magnetic Variation	100 ms	
129025	Position, Rapid Update	100 ms	
129026	COG & SOG Rapid Update	250 ms	
129029	GNSS Position Data	1000 ms	
129033	Time & Date	Note 1, 2, 3	
129538	GNSS Control Status	Note 1, 2	
129539	GNSS DOPs	1000 ms	
129540	GNSS Sats in View	1000 ms	
129547	GNSS Pseudo Range Error Statistics	Note 1, 2	
130310	Environmental Parameters - DEPRECATED	500 ms	
130312	Temperature - DEPRECATED	2000 ms	
130314	Actual Pressure	2000 ms	
130316	Temperature, Extended Range	2000 ms	
130577	Direction Data	1000 ms	
130578	Vessel Speed Components	250 ms	
130816	Self Test Report	-	- Proprietary PGN - Output for Self Test Group Function received.
130817	Furuno GNSS Control Status	Note 2	- Proprietary PGN
130818	Heading & Attitude Sensor Control Status	Note 2	- Proprietary PGN
130819	Motion Sensor Control Status	Note 2	- Proprietary PGN
130820	Motion Sensor Status	1000 ms	- Proprietary PGN

PGN	Name	Remarks	
130822	Unit Division Code	Note 2	- Proprietary PGN
130823	Blower Control Status	Note 2	- Proprietary PGN
130826	Multi Sats in View	1000 ms	- Proprietary PGN
130833	Device Position and Ship Dimension Report	Note 2	- Proprietary PGN
130834	Position of Speed Measurement	Note 2	- Proprietary PGN
130842	Six Degrees of Freedom Movement	Note 2	- Proprietary PGN
130843	Heel Angle & Roll Information	100 ms	- Proprietary PGN
130845	Multi Sats In View Extended	1000 ms	- Proprietary PGN
130846	Motion Sensor Status Extended	1000 ms	- Proprietary PGN
130847	System Debug Trace Data Stream	Note 2	- Proprietary PGN

Note 1: PGN to output independently when “PGN: 059904” or “PGN: 126208” requested.

Note 2: PGN to output independently when “PGN: 126208” requested.

Note 3: PGN to output regularly when “PGN: 126208” requested.

5. MAINTENANCE, TROUBLE-SHOOTING

This chapter provides the information for keeping your unit in good working order.

NOTICE

Do not apply paint, anti-corrosive sealant or contact spray to coating or plastic parts of the equipment.

Those items contain organic solvents that can damage coating and plastic parts, especially plastic connectors.

5.1 Preventive Maintenance

Regular maintenance is important for good performance. Following the procedures in the table below will help maintain performance.

Preventive maintenance

Item	Check point	Remedy
Connector	Check that connector is firmly fastened.	Reconnect cable if it has loosened.
Cabling	Visually check cabling for signs of wear and damage.	Replace damaged cables.
Cover	Cleanliness of cover	Dust can be removed with a soft cloth. Do not use chemical based cleaners to clean the cover, as they can remove paint and markings and deform the cover.

5.2 Troubleshooting

This section provides basic troubleshooting which the user may follow to restore normal operation. If the problem is not rectified, contact your dealer for advice.

Symptom	Possible cause and remedy
Heading is not output.	Check installation site; <ul style="list-style-type: none"> • Check for interfering objects near the antenna. • Check the installation site and mounting base for vibration. • Check for antenna of radar, radio equipment, etc. near the installation site. Check connections; <ol style="list-style-type: none"> 1) NMEA 2000 bus connection <ul style="list-style-type: none"> • Check that the connector on the SC-33 is tightly connected. • Check that no stress is applied to the cable and that a loop has been made with the cable to prevent cable stress. • Check that terminators (120 ohm) are attached at each end of the NMEA 2000 network. • Check that the input voltage to the SC-33 is between 9 to 32 VDC. • Check that all devices connected to the NMEA 2000 bus are within the current capacity of the bus. • Check that the cable (FRU-NMEA-PMMF-060 (6m)) is used. (If power is fed through a trunk line, the feeder cable shall be no longer than 6 m). • If power to the SC-33 is fed directly from the ship's mains, check breaker switch on mains switchboard and fuse in power cable. 2) IF-NMEASC interface unit connection: See the IF-NMEASC's operator's manual.
Heading output stops often. Position and GNSS-related items are output but heading is not	<ul style="list-style-type: none"> • Check for obstructions near the SC-33. • Check installation site for vibrations. • Check if other antennas (radar, radio, etc.) are near the installation site.
Equipment in NMEA 2000 network malfunctions when SC-33 is connected.	<ul style="list-style-type: none"> • Check that terminators (120 ohm) are attached at each end of the NMEA 2000 network. • Check that the input voltage to the SC-33 is between 9 to 32 VDC. • Check that all devices connected to the NMEA 2000 bus are within the current capacity of the bus. • Check that the cable (FRU-NMEA-PMMF-060 (6m)) is used. (If power is fed through a trunk line, the feeder cable shall be no longer than 6 m).
Heading is output normally in fine weather but is not output in bad weather.	<ul style="list-style-type: none"> • Check the installation site for vibrations.
Autopilot jerks suddenly.	<ul style="list-style-type: none"> • Check for obstructions near the SC-33. • Check the installation site and mounting base for vibrations. • Check if other antennas (radar, radio, etc.) are near the installation site. • Check operation at the autopilot: <ol style="list-style-type: none"> 1) Check that the rudder angle can be confirmed when heading output has stopped. Check that the necessary alarms are output. Confirm that the rudder returns to 0° and the set rudder angle is maintained. 2) Confirm that rudder does not jerk violently when heading output is resumed. For example, check that the setting for rudder angle limit is suitable.

①

②

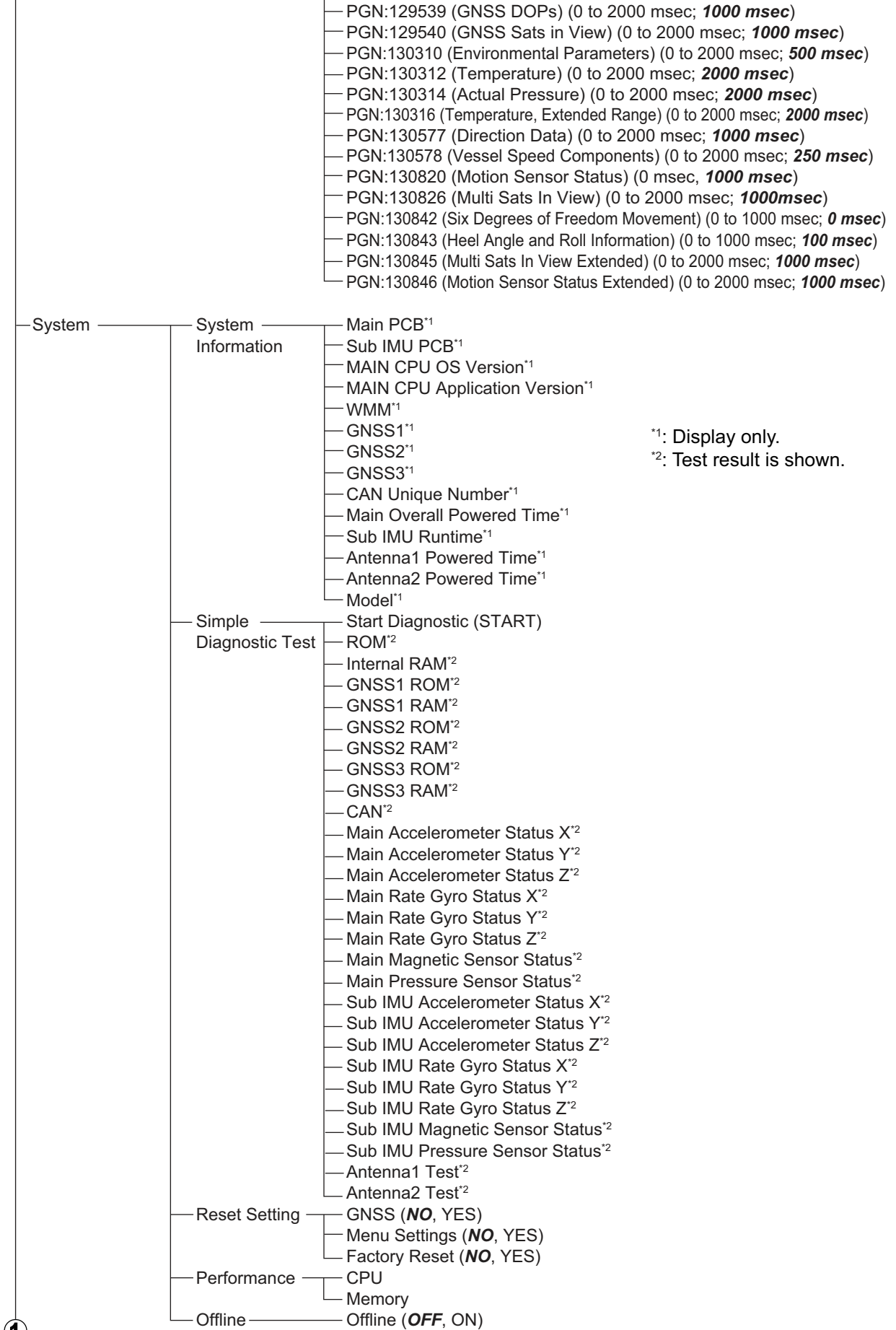

APPENDIX 1 MENU TREE

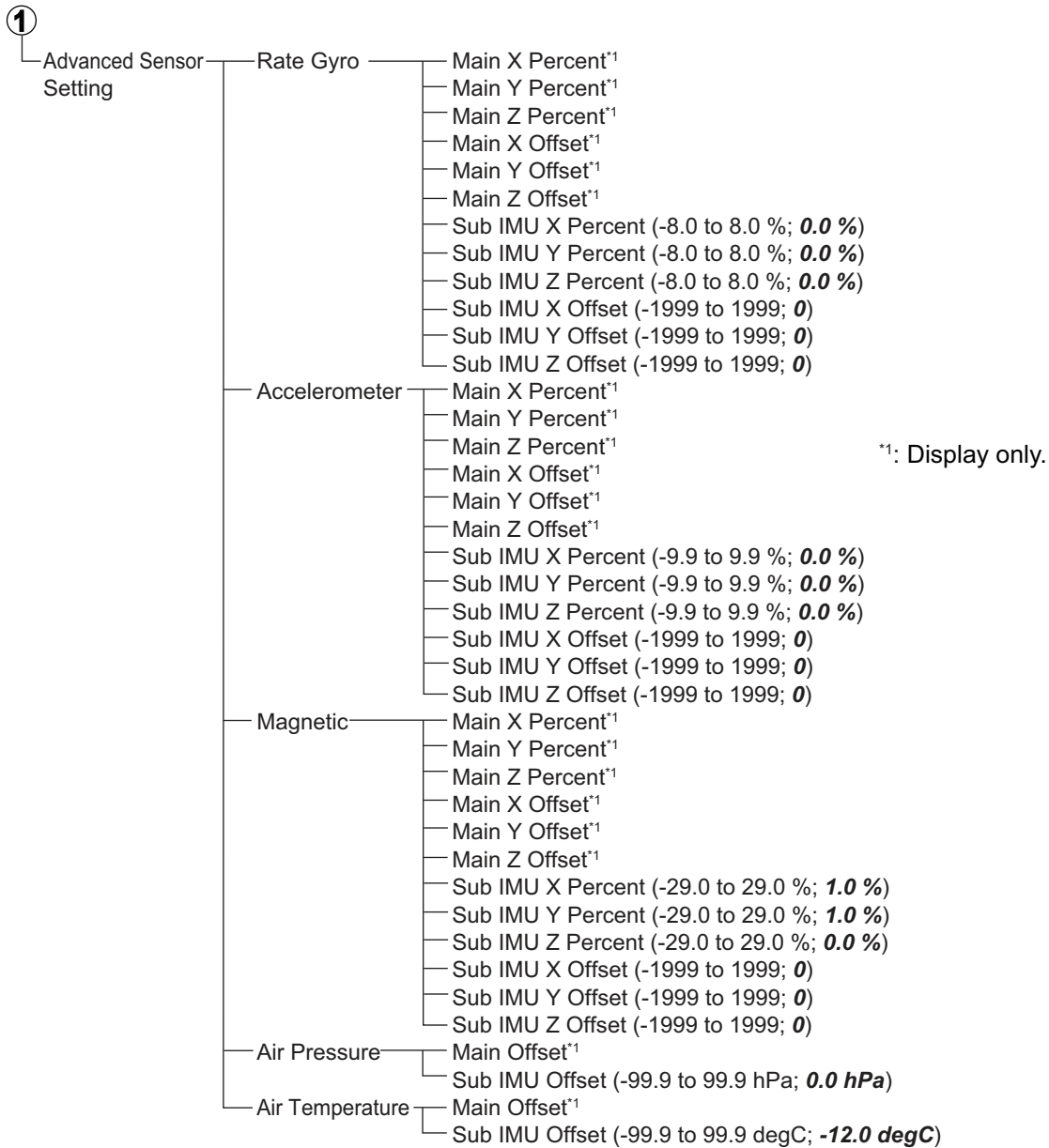

APPENDIX 2 WHAT IS SBAS?

A satellite based augmentation system, or SBAS (Satellite Based Augmentation System), is an augmentation system that uses additional messages from satellite broadcasts to support regional and wide area augmentation. SBAS provides GPS signal corrections to SBAS users, for even better position accuracy, through the GPS error corrections that are widely broadcasted from the geostationary satellite.

SBAS is used in America, Europe, Japan and India.

- America: WAAS (Wide Area Augmentation System)
- Europe: EGNOS (Euro Geostationary Navigation Overlay Service)
- Japan: MSAS (Multi-Functional Satellite Augmentation System)
- India: GAGAN (GPS And GEO Augmented Navigation)

These four systems have interoperability. The illustration below shows the coverage area for each provider. This manual uses "SBAS" for these four providers generically.

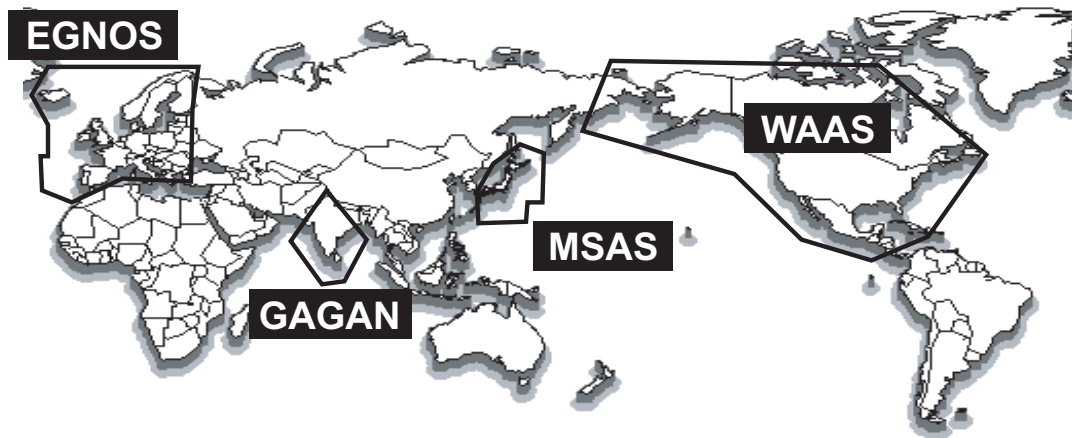

Provider	Satellite type	Longitude	Satellite No.
WAAS	Intelsat Galaxy XV	133°W	135
	TeleSat Anik F1R	107.3°W	138
	Inmarsat-4-F3	98°W	133
EGNOS	Inmarsat-3-F2/AOR-E	15.5°W	120
	Artemis	21.5°E	124
	Inmarsat-4-F2	25°E	126
	SES-5	5°E	136
MSAS	MTSAT-1R	140°E	129
	MTSAT-2	145°E	137
GAGAN	GSAT-8	55°E	127
	GSAT-10	83°E	128

As of March 6th, 2014

**SPECIFICATIONS OF SATELLITE COMPASS
SC-33**

1 GENERAL

- 1.1 Frequency L1 1575.42MHz (GPS/Galileo/QZSS), 1602.5625MHz (GLONASS)
- 1.2 Tracking code C/A (GPS/QZSS), E1B (Galileo), L1OF (GLONASS)
- 1.3 Attitude accuracy Heading/ Roll/ Pitch: 0.4° rms
- 1.4 Follow-up 45°/sec
- 1.5 Heave accuracy 30 cm
- 1.6 Attitude setting time 90 s approx.
- 1.7 Position accuracy (dependent on ionospheric activity and multipath)
 - GNSS 5 m approx. (2drms, HDOP<4)
 - SBAS 4 m approx. (2drms, HDOP<4)
 - WAAS 3 m approx. (2drms, HDOP<4)
- 1.8 Position fixing time 60 s approx.
- 1.9 Update interval Attitude: 50 Hz max, Position: 10 Hz max.
- 1.10 Ship's speed accuracy
 - Number of satellite ≥ 5: 0.2% of ship's speed or 0.02 kn rms, whichever is greater
 - Number of satellite 3 to 4: 1% of ship's speed or 0.1 kn rms, whichever is greater
- 1.11 Pressure sensor
 - Measuring range 850 to 1100 hPa (ambient temperature: 0 to +50°C)
 - Accuracy ±1.0 hPa (adjusted value after offset regulation)
- 1.12 Temperature sensor
 - Measuring range -20°C to +55°C (relative speed 4 kn or more)
 - Accuracy ±2.0°C (adjusted value after offset regulation)
- 1.13 Interface port NMEA2000: 1 port
 - Input PGN 059392/904, 060160/416/928, 061184, 065240, 126208
 - Output PGN 059392, 060928, 061184, 065280,
126208/464/992/993/996/998, 127250/251/252/257/258,
129025/026/029/033/538/539/540/547,
130310/312/314/316/577/578/816/817/818/819/820/822/823/826,
130833/834/842/843/845/846/847

2 POWER SUPPLY

12-24 VDC (10.8-31.2 V): 0.4-0.2 A (LEN: 11 at 9 VDC)

3 ENVIRONMENTAL CONDITIONS

- 3.1 Ambient temperature -25°C to +55°C (storage: -30°C to +70°C)
- 3.2 Relative humidity 95% or less at +40°C
- 3.3 Degree of protection IP56
- 3.4 Vibration IEC 60945 Ed.4

4 UNIT COLOR



N9.5

PACKING LIST

20BJ-X-9851 -1 1/1

SC-33-J-0, SC-33E-0

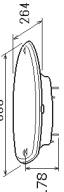
A-1

NAME	OUTLINE	DESCRIPTION/CODE No.	QTY
ユニット			
センサー		SC-33 000-035-093-00	1
工事材料			
INSTALLATION MATERIALS			
工事材料		CP20-04401 001-508-130-00	1
図書			
DOCUMENT			
取扱説明書		OM*-72850-* 000-194-661-1* **	1
OPERATOR'S MANUAL			

コード番号末尾の[**]は、選択品の代表コードを表します。
CODE NUMBER ENDING WITH "**" INDICATES THE CODE NUMBER OF REPRESENTATIVE MATERIAL.

(略図の寸法は、参考値です。DIMENSIONS IN DRAWING FOR REFERENCE ONLY.)





C7285-Z01-B

PACKING LIST

20BJ-X-9852 -3 1/1

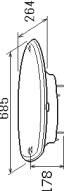
SC-33-J-6, SC-33-E-6

A-2

NAME	OUTLINE	DESCRIPTION/CODE No.	QTY
ユニット			
センサー		SC-33 000-035-093-00	1
工事材料			
INSTALLATION MATERIALS			
ケーブル(クモヒ)MIEA		FRU-NMIEA-PMMF-060 001-533-080-00	1
CABLE ASSEMBLY			
工事材料		CP20-04401 001-508-130-00	1
図書			
DOCUMENT			
取扱説明書		OM*-72850-* 000-194-661-1* **	1
OPERATOR'S MANUAL			

コード番号末尾の[**]は、選択品の代表コードを表します。
CODE NUMBER ENDING WITH "**" INDICATES THE CODE NUMBER OF REPRESENTATIVE MATERIAL.



(略図の寸法は、参考値です。DIMENSIONS IN DRAWING FOR REFERENCE ONLY.)

C7285-Z02-D

PACKING LIST

OP20-50

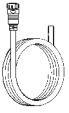

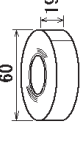
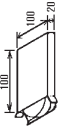
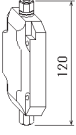
A-4

NAME	OUTLINE	DESCRIPTION/CODE No.	QTY
キット内容 KIT PARTS			
ケーブル(ミニヒン)NMEA CABLE ASSEMBLY		FRU-NMEA-PFF-060 000-194-606-10	1
抵抗器(組品) RESISTOR ASSEMBLY		120.0HM-1007#24-L50 000-167-746-11	1
ビニールテープ VINYL TAPE		0.2X19X10000MM 70 000-172-691-10	1
自己接着テープ SELF-BONDING TAPE		NO.15 000-174-646-10	1
防水中継ボックス WATERPROOF RELAY BOX		JPBS 06 000-194-639-10	1

PACKING LIST

SC-33-J-15

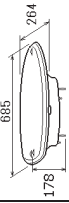

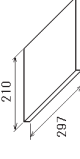
A-3

NAME	UNIT	OUTLINE	DESCRIPTION/CODE No.	QTY
ユニット SENSOR			SC-33 000-035-093-00	1
工事材料 INSTALLATION MATERIALS				
ケーブル(ミニヒン)NMEA CABLE ASSEMBLY			FRU-NMEA-NFF-R15 001-533-090-00	1
工事材料 INSTALLATION MATERIALS			CP20-04401 001-508-130-00	1
図書 DOCUMENT				
取扱説明書 OPERATOR'S MANUAL			OMJ-72850-* 000-194-660-1*	1

(略図の寸法は、参考値です。DIMENSIONS IN DRAWING FOR REFERENCE ONLY.)

(略図の寸法は、参考値です。DIMENSIONS IN DRAWING FOR REFERENCE ONLY.)

FURUNO

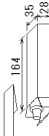
CODE NO.		001-508-130-00		208J-X-9401-0	
TYPE		CP20-04401		1/1	
工事材料表					
INSTALLATION MATERIALS					
番号 NO.	名称 NAME	略図 OUTLINE	型名/規格 DESCRIPTIONS	数量 QTY	用途/備考 REMARKS
1	六角ナット 1/2 HEX NUT		M10 SUS304 CODE NO. 000-166-475-10	8	
2	ハネばね SPRING WASHER		M10 SUS304 CODE NO. 000-167-233-10	4	
3	平座金 FLAT WASHER		M10 SUS316L CODE NO. 000-167-416-10	4	
4	接着剤塗布 ADHESIVE		TB5211 50G CODE NO. 001-477-870-00	1	

(略図の寸法は、参考値です。 DIMENSIONS IN DRAWING FOR REFERENCE ONLY.)

FURUNO ELECTRIC CO., LTD.

C7285-M01-A



表1 TABLE 1

寸法区分 (mm) DIMENSION	公差 (mm) TOLERANCE
$L \leq 50$	± 1.5
$50 < L \leq 100$	± 2.5
$100 < L \leq 500$	± 3
$500 < L \leq 1000$	± 4

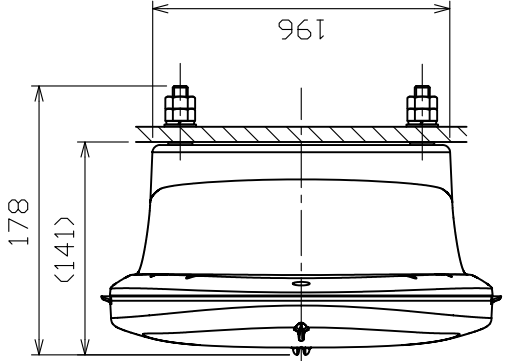
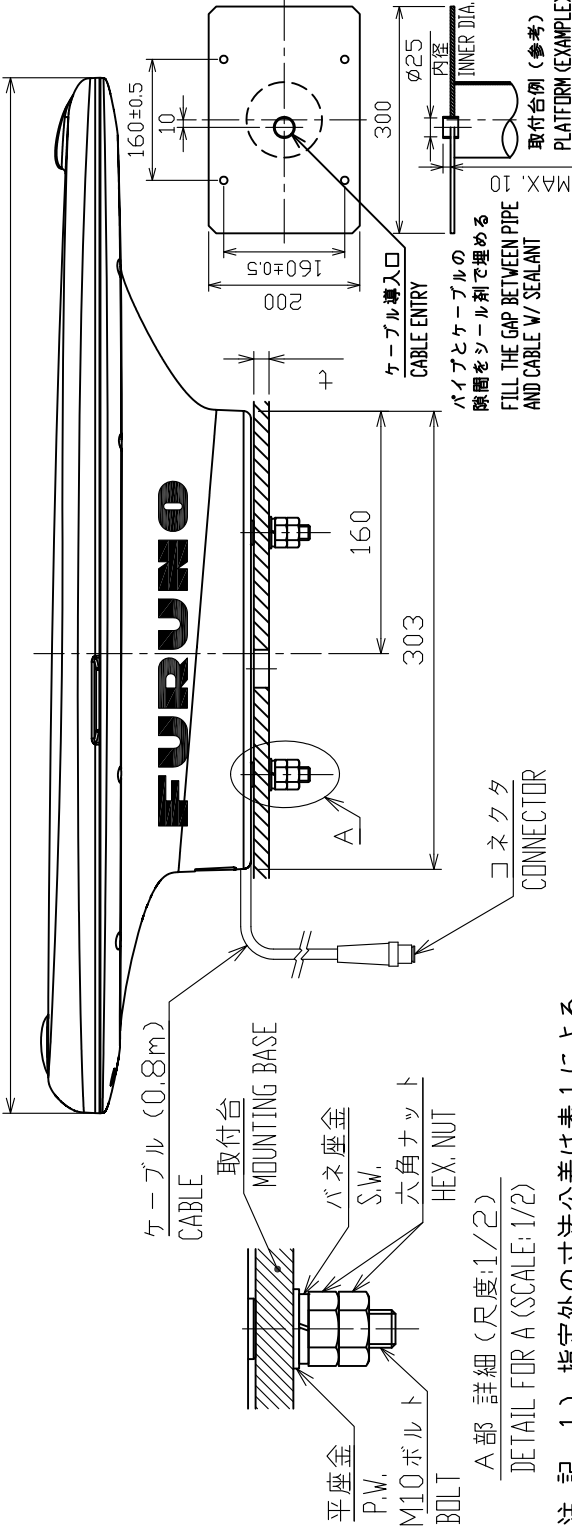
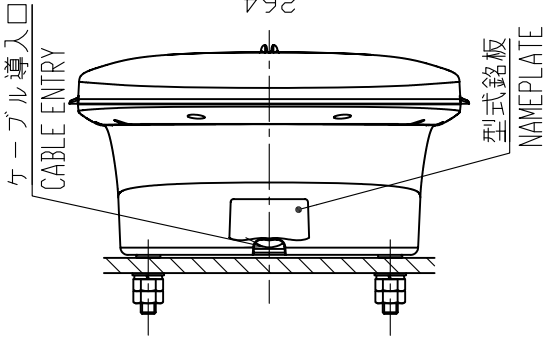
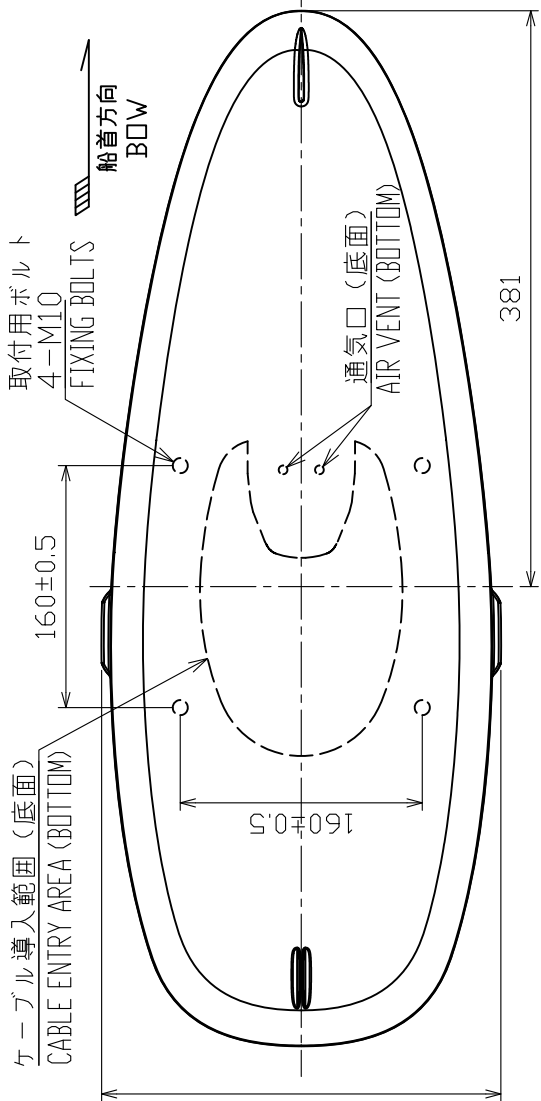

取付台例 (参考) (尺度: 1/10)
PLATFORM (EXAMPLE) (SCALE: 1/10)

DRAWN	25/Feb/2021	I. YAMASAKI	TITLE	SC-33
CHECKED	25/Feb/2021	H. MAKI	名称	サテライトコンパス
APPROVED	26/Feb/2021	H. MAKI	外寸図	
SCALE	1/5	質量 2.8 kg 寸法 1/5	NAME	SATELLITE COMPASS
FIG. No.	C7285-601-C	質量は工材を含みません。 MASS DOES NOT INCLUDE INST. MATERIALS.	OUTLINE DRAWING	
		REF. No.	20-041-300G-1	

- 注記 1) 指定外の寸法公差は表 1 による。
2) 取付台の厚さ (t) は、5 以上 15 以下とする。
- NOTE 1. TABLE 1 INDICATES TOLERANCE OF DIMENSIONS WHICH IS NOT SPECIFIED.
2. MOUNTING BASE THICKNESS (t): $5 \leq t \leq 15$.

FURUNO Worldwide Warranty for Pleasure Boats (Except North America)

This warranty is valid for products manufactured by Furuno Electric Co. (hereafter FURUNO) and installed on a pleasure boat. Any web based purchases that are imported into other countries by anyone other than a FURUNO certified dealer may not comply with local standards. FURUNO strongly recommends against importing these products from international websites as the imported product may not work correctly and may interfere with other electronic devices. The imported product may also be in breach of the local laws and mandated technical requirements. Products imported into other countries as described previously shall not be eligible for local warranty service.

For products purchased outside of your country please contact the national distributor of Furuno products in the country where purchased.

This warranty is in addition to the customer's statutory legal rights.

1. Terms and Conditions of Warranty

FURUNO guarantees that each new FURUNO product is the result of quality materials and workmanship. The warranty is valid for a period of 2 years (24 months) from the date of the invoice, or the date of commissioning of the product by the installing certified dealer.

2. FURUNO Standard Warranty

The FURUNO standard warranty covers spare parts and labour costs associated with a warranty claim, provided that the product is returned to a FURUNO national distributor by prepaid carrier.

The FURUNO standard warranty includes:

- Repair at a FURUNO national distributor
- All spare parts for the repair
- Cost for economical shipment to customer

3. FURUNO Onboard Warranty

If the product was installed/commissioned and registered by a certified FURUNO dealer, the customer has the right to the onboard warranty.

The FURUNO onboard warranty includes

- Free shipping of the necessary parts
- Labour: Normal working hours only
- Travel time: Up to a maximum of two (2) hours
- Travel distance: Up to a maximum of one hundred and sixty (160) KM by car for the complete journey

4. Warranty Registration

For the Standard Warranty - presentation of product with serial number (8 digits serial number, 1234-5678) is sufficient. Otherwise, the invoice with serial number, name and stamp of the dealer and date of purchase is shown.

For the Onboard Warranty your FURUNO certified dealer will take care of all registrations.

5. Warranty Claims

For the Standard Warranty - simply send the defective product together with the invoice to a FURUNO national distributor. For the Onboard Warranty – contact a FURUNO national distributor or a certified dealer. Give the product's serial number and describe the problem as accurately as possible.

Warranty repairs carried out by companies/persons other than a FURUNO national distributor or a certified dealer is not covered by this warranty.

6. Warranty Limitations

When a claim is made, FURUNO has a right to choose whether to repair the product or replace it.

The FURUNO warranty is only valid if the product was correctly installed and used. Therefore, it is necessary for the customer to comply with the instructions in the handbook. Problems which result from not complying with the instruction manual are not covered by the warranty.

FURUNO is not liable for any damage caused to the vessel by using a FURUNO product.

The following are excluded from this warranty:

- a. Second-hand product
- b. Underwater unit such as transducer and hull unit
- c. Routine maintenance, alignment and calibration services.
- d. Replacement of consumable parts such as fuses, lamps, recording papers, drive belts, cables, protective covers and batteries.
- e. Magnetron and MIC with more than 1000 transmitting hours or older than 12 months, whichever comes first.
- f. Costs associated with the replacement of a transducer (e.g. Crane, docking or diver etc.).
- g. Sea trial, test and evaluation or other demonstrations.
- h. Products repaired or altered by anyone other than the FURUNO national distributor or an authorized dealer.
- i. Products on which the serial number is altered, defaced or removed.
- j. Problems resulting from an accident, negligence, misuse, improper installation, vandalism or water penetration.
- k. Damage resulting from a force majeure or other natural catastrophe or calamity.
- l. Damage from shipping or transit.
- m. Software updates, except when deemed necessary and warrantable by FURUNO.
- n. Overtime, extra labour outside of normal hours such as weekend/holiday, and travel costs above the 160 KM allowance
- o. Operator familiarization and orientation.

FURUNO Electric Company, March 1, 2011

FURUNO Warranty for North America

FURUNO U.S.A., Limited Warranty provides a twenty-four (24) months LABOR and twenty-four (24) months PARTS warranty on products from the date of installation or purchase by the original owner. Products or components that are represented as being waterproof are guaranteed to be waterproof only for, and within the limits, of the warranty period stated above. The warranty start date may not exceed eighteen (18) months from the original date of purchase by dealer from Furuno USA and applies to new equipment installed and operated in accordance with Furuno USA's published instructions.

Magnetrons and Microwave devices will be warranted for a period of 12 months from date of original equipment installation.

Furuno U.S.A., Inc. warrants each new product to be of sound material and workmanship and through its authorized dealer will exchange any parts proven to be defective in material or workmanship under normal use at no charge for a period of 24 months from the date of installation or purchase.

Furuno U.S.A., Inc., through an authorized Furuno dealer will provide labor at no cost to replace defective parts, exclusive of routine maintenance or normal adjustments, for a period of 24 months from installation date provided the work is done by Furuno U.S.A., Inc. or an AUTHORIZED Furuno dealer during normal shop hours and within a radius of 50 miles of the shop location.

A suitable proof of purchase showing date of purchase, or installation certification must be available to Furuno U.S.A., Inc., or its authorized dealer at the time of request for warranty service.

This warranty is valid for installation of products manufactured by Furuno Electric Co. (hereafter FURUNO). Any purchases from brick and mortar or web-based resellers that are imported into other countries by anyone other than a FURUNO certified dealer, agent or subsidiary may not comply with local standards. FURUNO strongly recommends against importing these products from international websites or other resellers, as the imported product may not work correctly and may interfere with other electronic devices. The imported product may also be in breach of the local laws and mandated technical requirements. Products imported into other countries, as described previously, shall not be eligible for local warranty service.

For products purchased outside of your country please contact the national distributor of Furuno products in the country where purchased.

WARRANTY REGISTRATION AND INFORMATION

To register your product for warranty, as well as see the complete warranty guidelines and limitations, please visit www.furunousa.com and click on "Support". In order to expedite repairs, warranty service on Furuno equipment is provided through its authorized dealer network. If this is not possible or practical, please contact Furuno U.S.A., Inc. to arrange warranty service.

FURUNO U.S.A., INC.
Attention: Service Coordinator
4400 N.W. Pacific Rim Boulevard
Camas, WA 98607-9408
Telephone: (360) 834-9300
FAX: (360) 834-9400

Furuno U.S.A., Inc. is proud to supply you with the highest quality in Marine Electronics. We know you had several choices when making your selection of equipment, and from everyone at Furuno we thank you. Furuno takes great pride in customer service.

Declaration of Conformity

[SC-33]

- Bulgarian (BG)** С настоящото Furuno Electric Co., Ltd. декларира, че гореспоменат тип радиосъоръжение е в съответствие с Директива 2014/53/ЕС, СИ 2017/1206. Цялостният текст на ЕС/УК декларацията за съответствие може да се намери на следния интернет адрес:
- Spanish (ES)** Por la presente, Furuno Electric Co., Ltd. declara que el tipo de equipo radioeléctrico arriba mencionado es conforme con la Directiva 2014/53/UE, SI 2017/1206. El texto completo de la declaración de conformidad de la EU/UK está disponible en la siguiente dirección Internet:
- Czech (CS)** Tímto Furuno Electric Co., Ltd. prohlašuje, že výše zmíněné typ rádiového zařízení je v souladu se směrnicí 2014/53/EU, SI 2017/1206. Úplné znění EU/SK prohlášení o shodě je k dispozici na této internetové adrese:
- Danish (DA)** Hermed erklærer Furuno Electric Co., Ltd., at ovennævnte radioudstyr er i overensstemmelse med direktiv 2014/53/EU, SI 2017/1206. EU/UK-overensstemmelseserklæringens fulde tekst kan findes på følgende internetadresse:
- German (DE)** Hiermit erklärt die Furuno Electric Co., Ltd., dass der oben genannte Funkanlagentyp der Richtlinie 2014/53/EU, SI 2017/1206 entspricht. Der vollständige Text der EU/UK-Konformitätserklärung ist unter der folgenden Internetadresse verfügbar:
- Estonian (ET)** Käesolevaga deklareerib Furuno Electric Co., Ltd., et ülalmainitud raadioseadme tüüp vastab direktiivi 2014/53/EL, SI 2017/1206 nõuetele. EL/GB vastavusdeklaratsiooni täielik tekst on kättesaadav järgmisel internetiaadressil:
- Greek (EL)** Με την παρούσα η Furuno Electric Co., Ltd., δηλώνει ότι ο προαναφερθέντας ραδιοεξοπλισμός πληροί την οδηγία 2014/53/ΕΕ, SI 2017/1206. Το πλήρες κείμενο της δήλωσης συμμόρφωσης ΕΕ/UK διατίθεται στην ακόλουθη ιστοσελίδα στο διαδίκτυο:
- English (EN)** Hereby, Furuno Electric Co., Ltd. declares that the above-mentioned radio equipment type is in compliance with Directive 2014/53/EU, SI 2017/1206. The full text of the EU/UK declaration of conformity is available at the following internet address:
- French (FR)** Le soussigné, Furuno Electric Co., Ltd., déclare que l'équipement radioélectrique du type mentionné ci-dessus est conforme à la directive 2014/53/UE, SI 2017/1206. Le texte complet de la déclaration UE/RU de conformité est disponible à l'adresse internet suivante:
- Croatian (HR)** Furuno Electric Co., Ltd. ovime izjavljuje da je gore rečeno radijska oprema tipa u skladu s Direktivom 2014/53/EU, SI 2017/1206. Cjeloviti tekst EU/UK izjave o sukladnosti dostupan je na sljedećoj internetskoj adresi:
- Italian (IT)** Il fabbricante, Furuno Electric Co., Ltd., dichiara che il tipo di apparecchiatura radio menzionato sopra è conforme alla direttiva 2014/53/UE, SI 2017/1206. Il testo completo della dichiarazione di conformità UE/RU è disponibile al seguente indirizzo Internet:
- Latvian (LV)** Ar šo Furuno Electric Co., Ltd. deklarē, ka augstāk minēts radioiekārta atbilst Direktīvai 2014/53/ES, SI 2017/1206. Pilns ES/AK atbilstības deklarācijas teksts ir pieejams šādā interneta vietnē:

- Lithuanian (LT) Aš, Furuno Electric Co., Ltd., patvirtinu, kad pirmiau minėta radijo įrenginių tipas atitinka Direktyvą 2014/53/ES, SI 2017/1206.
Visas ES/JK atitikties deklaracijos tekstas prieinamas šiuo interneto adresu:
- Hungarian (HU) Furuno Electric Co., Ltd. igazolja, hogy fent említett típusú rádióberendezés megfelel a 2014/53/EU, SI 2017/1206 irányelvnek.
Az EU/EK-megfelelőségi nyilatkozat teljes szövege elérhető a következő internetes címen:
- Maltese (MT) B'dan, Furuno Electric Co., Ltd., niddikjara li msemmija hawn fuq-tip ta' taghmir tar-radju huwa konformi mad-Direttiva 2014/53/UE, SI 2017/1206.
It-test kollu tad-dikjarazzjoni ta' konformità tal-UE/RU huwa disponibbli f'dan l-indirizz tal-Internet li ġej:
- Dutch (NL) Hierbij verklaar ik, Furuno Electric Co., Ltd., dat het hierboven genoemde type radioapparaat conform is met Richtlijn 2014/53/EU, SI 2017/1206.
De volledige tekst van de EU/VK-conformiteitsverklaring kan worden geraadpleegd op het volgende internetadres:
- Polish (PL) Furuno Electric Co., Ltd. niniejszym oświadcza, że wyżej wymieniony typ urządzenia radiowego jest zgodny z dyrektywą 2014/53/UE, SI 2017/1206.
Pełny tekst deklaracji zgodności UE/UK jest dostępny pod następującym adresem internetowym:
- Portuguese (PT) O(a) abaixo assinado(a) Furuno Electric Co., Ltd. declara que o mencionado acima tipo de equipamento de rádio está em conformidade com a Diretiva 2014/53/UE, SI 2017/1206.
O texto integral da declaração de conformidade da EU/UK está disponível no seguinte endereço de Internet:
- Romanian (RO) Prin prezenta, Furuno Electric Co., Ltd. declară că echipamentul radio menționat mai sus este în conformitate cu Directiva 2014/53/UE, SI 2017/1206.
Textul integral al declarației de conformitate UE/RU este disponibil la următoarea adresă internet:
- Slovak (SK) Furuno Electric Co., Ltd. týmto vyhlasuje, že vyššie spomínané rádiové zariadenie typu je v súlade so smernicou 2014/53/EÚ, SI 2017/1206.
Úplné EÚ/SK vyhlásenie o zhode je k dispozícii na tejto internetovej adrese:
- Slovenian (SL) Furuno Electric Co., Ltd. potrjuje, da je zgoraj omenjeno tip radijske opreme skladen z Direktivo 2014/53/EU, SI 2017/1206.
Celotno besedilo izjave EU/ZK o skladnosti je na voljo na naslednjem spletnem naslovu:
- Finnish (FI) Furuno Electric Co., Ltd. vakuuttaa, että yllä mainittu radiolaitetyyppi on direktiivin 2014/53/EU, SI 2017/1206 mukainen.
EU/UK-vaatimustenmukaisuusvakuutuksen täysimittainen teksti on saatavilla seuraavassa internetosoitteessa:
- Swedish (SV) Härmed försäkrar Furuno Electric Co., Ltd. att ovan nämnda typ av radioutrustning överensstämmer med direktiv 2014/53/EU, SI 2017/1206.
Den fullständiga texten till EU/Storbritannien-försäkran om överensstämmelse finns på följande webbadress:

Online Resource

http://www.furuno.com/en/support/red_doc

Notice for radiated immunity

The test for the radiated immunity is performed up to 2.7 GHz only without the special condition of spot frequency being applied. There is a chance that this equipment may interfere with allocated services in the frequency range of 2.7 GHz to 6 GHz, particularly in harbors, rivers, lake banks, etc.

PSTI Statement of Compliance

We **FURUNO ELECTRIC CO., LTD.**

(Name of manufacturer of the product)

9-52 Ashihara-Cho, Nishinomiya City, 662-8580, Hyogo, Japan

(Address of manufacturer of the product)

declare under our sole responsibility that the product

**SATELLITE COMPASS,
SC-33**

(Product type, batch)

December / 31 / 2028

(Support period for the product)

https://www.furuno.co.jp/en/csr/sociality/customer/product_security.html

(Weblink for latest information and contact to report to the manufacturer security issues)

to which this declaration relates conforms to the following standard(s) or other normative document(s)

Product Security and Telecommunications Infrastructure Act 2022

Product Security and Telecommunications Infrastructure (Security Requirements for
Relevant Connectable Products) Regulations 2023 Schedule 1

On behalf of Furuno Electric Co., Ltd.

Nishinomiya City, Japan
10 July 2025

(Place and date of issue)

Akihiko Kanechika
Department General Manager
Quality Assurance Department

(Signature, name and function of the signatory)



FURUNO ELECTRIC CO., LTD.

9-52 Ashihara-cho,
Nishinomiya, 662-8580, JAPAN

• FURUNO Authorized Distributor/Dealer

All rights reserved. Printed in Japan

Pub. No. OME-72850-F

(REFU) SC-33

A : MAR. 2018
F : AUG. 06, 2025



0 0 0 1 0 0 5 8 6 2 0