



v60Ka 2 XCVR

65 cm Ka-Band
Maritime VSAT Antenna System

Installation & Operation User Guide

Serial number of the product

This serial number will be required for all troubleshooting or service inquiries.

Intellian

© 2022 Intellian Technologies, Inc. All rights reserved. Intellian and the Intellian logo are trademarks of Intellian Technologies, Inc., registered in the U.S. and other countries. The v60Ka 2 XCVR is a trademark of Intellian Technologies, Inc. Intellian may have patents, patent applications, trademarks, copyrights, or other intellectual property rights covering subject matter in this document. Except as expressly provided in any written license agreement from Intellian, the furnishing of this document does not give you any license to these patents, trademarks, copyrights, or other intellectual property. All other logos, trademarks, and registered trademarks are the property of their respective owners. Information in this document is subject to change without notice. Every effort has been made to ensure that the information in this manual is accurate. Intellian is not responsible for printing or clerical errors.

Disclaimer

The information in this user manual is subject to change without prior notice throughout the product life cycle. The printed version of the user manual is periodically updated, but it may contain inaccuracies or omissions compared to the most recent product information. The most up-to-date information is always available on our website at intelliantech.com.

Table of Contents

Chapter 1. Precautions	8
1.1 Warnings, Cautions, and Notes	8
1.2 General Precautions	8
Chapter 2. Certifications	9
Chapter 3. Introduction	13
3.1 Introduction of v60Ka 2 XCVR	13
3.2 Features of v60Ka 2 XCVR	14
Chapter 4. Planning Installation	15
4.1 Selecting Installation Site	15
4.1.1 Minimize Satellite Blockage	15
4.1.2 Avoid RF Interference	16
4.1.3 RF Hazard Precautions	16
4.2 System Package	18
4.2.1 Above Deck Unit (ADU)	18
4.2.2 Antenna Control Unit (ACU)	18
4.2.3 Packing List	19
4.3 System Cables (Customer Supplied)	20
4.3.1 Antenna RF Cable (Customer Supplied)	20
4.3.2 Gyrocompass Cable (Customer Supplied)	20
4.4 Unpacking System Package	21
Chapter 5. Installing Above Deck Unit (ADU)	22
5.1 Antenna Dimensions	22
5.2 Antenna Mounting Hole Pattern	23
5.3 Designing Mast (Example Only)	24
5.4 Routing RF Cable on Mast (Example Only)	28
5.5 Removing Antenna from Wooden Pallet	30
5.6 Moving Antenna Above Mast	31
5.7 Inserting Waterproof Foam	32
5.8 Mounting Antenna on Mast	33
5.9 Connecting RF Cable to Antenna	34
Chapter 6. Installing Below Deck Unit (BDU)	36
6.1 Selection of BDU Installation Site	36
6.2 ACU Dimensions	36
6.3 Mounting ACU	37
6.4 Antenna System Configurations	38
6.4.1 Single Antenna System Configuration (Basic Antenna System)	38
6.4.2 Dual Antenna System Configuration (Optional)	39

6.5 ACU Cable Connection	40
6.5.1 ACU Back Panel Connectors	40
6.5.2 ACU Connector Pinout Guide	40
6.5.3 Connecting Power to ACU	45
6.5.4 Connecting ACU to Antenna	45
6.5.5 Connecting ACU to Antenna in Dual Antenna System (Optional)	46
6.5.6 Connecting Primary/Secondary ACUs in Dual Antenna System (Optional)	46
6.5.7 Connecting ACU to Modem	47
6.5.8 Connecting ACU to Switch Router	47
6.5.9 Connecting ACU to Ship Gyrocompass	48
6.6 ACU to PC Communication Setup	49
6.6.1 TCP/IP Connection	49
6.6.2 USB Connection	50
6.6.3 Wi-Fi Connection	51
Chapter 7. Operating Install Wizard	52
7.1 Turning On System	52
7.2 Accessing AptusNX	52
7.3 Modem Configuration	53
7.4 Starting Install Wizard	55
Chapter 8. Operating ACU	60
8.1 ACU Front Panel View	60
8.2 ACU Display Menu	61
8.3 Startup	62
8.4 Diagnosis	64
8.5 Antenna Information	66
8.6 Interface Information	67
8.7 USB Function	68
8.7.1 Log Download	69
8.7.2 Firmware Upload	71
8.7.3 Backup to USB	72
8.7.4 Restore From USB	73
Chapter 9. Using AptusNX	74
9.1 Introduction	74
9.2 Accessing AptusNX for ACU	74
9.3 Main Page (Page Login)	75
9.4 Top Menus	76
9.5 Account Menu	78
9.5.1 Account	78
9.5.2 Registration	79
9.5.3 System	80
9.5.4 User Manager	81
9.6 Dashboard	82
9.6.1 How to Add & Remove Panels (Dashboard Setting)	83
9.6.2 How to Arrange Dashboard Layout	84
9.6.3 How to Use Shortcut Settings	85

9.7 Install Wizard	86
9.8 System Tools	87
9.8.1 Firmware Upgrade	87
9.8.2 iARM Upgrade	89
9.8.3 iARM Save & Reboot	91
9.8.4 Satellite Library	92
9.8.5 Graph	93
9.9 System Troubleshooting	94
9.9.1 Diagnosis	94
9.9.2 Antenna Log	96
9.9.3 Antenna Event Log	97
9.9.4 Support	97
9.10 System Setting	98
9.10.1 Ship Setting	98
9.10.2 Antenna Setting	100
9.10.3 Tracking Satellite Setting	103
9.10.4 Network Configuration	104
9.10.5 Modem/BUC Setting	107
9.10.6 SNMP Setting	109
9.10.7 Backup & Restore Setting	110
9.10.8 Mediator Setting for Dual Antenna System (Optional)	111
Chapter 10. Specification	113
10.1 Technical Specification	113
10.2 Environmental Specification	114
Chapter 11. Warranty	115
Chapter 12. Appendix	116
12.1 Appendix A. Tightening Torque Specification	116
12.2 Appendix B. Starting Dual Antenna System (Optional)	117
12.2.1 Configuration of Dual Antenna System	117
12.2.2 Setting Up Dual Antenna System	117
12.2.3 Performing Install Wizard	119
12.2.4 Monitoring Dual Antenna System	120
12.3 Appendix C. Important notice of waterproofing connector	121
12.3.1 Introduction	121
12.3.2 Outline of taping	121
12.3.3 Procedure	121

List of Figures



Chapter 4. Planning Installation	15
Figure 1: Elevation Limit of Obstacles	15
Figure 2: Potential RF Interference	16
Figure 3: Antenna focal line safety distance	17
Figure 4: Radome and Pedestal	18
Figure 5: Front Panel of ACU	18
Figure 6: Back Panel of ACU	18
Chapter 5. Installing Above Deck Unit (ADU)	22
Figure 7: Antenna Dimensions	22
Figure 8: Antenna Mounting Hole Template	23
Figure 9: Recommended Size of Mast (Option 1)	25
Figure 10: Recommended Size of Mast (Option 2)	26
Figure 11: Recommended Size of Mast (Option 2)	27
Figure 12: Routing Cable Through Outside of Mast	28
Figure 13: Routing Cable Through Inside of Mast	29
Figure 14: Installing Sequence of Bolts	33
Figure 15: Installing Bolts for Antenna-Mast Assembly	33
Chapter 6. Installing Below Deck Unit (BDU)	36
Figure 16: ACU Dimensions	36
Figure 17: 19-inch Rack Mounting ACU	37
Figure 18: Single Antenna System Configuration	38
Figure 19: Dual Antenna System Configuration	39
Figure 20: ACU Back Panel Connectors	40
Figure 21: Connecting Power to ACU	45
Figure 22: ACU to Antenna Cable Connection in Single Antenna System	45
Figure 23: ACU to Antenna Cable Connection for Dual Antenna System	46
Figure 24: Primary and Secondary ACU Cable Connection in Dual Antenna System	46
Figure 25: ACU to Modem Cable Connection	47
Figure 26: ACU to Switch Router Cable Connection	47
Figure 27: ACU to Ship's Gyrocompass Cable Connection	48
Figure 28: NMEA 0183 Gyrocompass Cable Connection	48
Figure 29: Front Panel Management LAN Port Connection	49
Figure 30: Front Panel USB Port Connection	50
Figure 31: Back Panel Wi-Fi Dongle Connection	51
Chapter 7. Operating Install Wizard	52
Figure 32: Front Panel Management LAN Port Connection	52
Chapter 8. Operating ACU	60
Figure 33: ACU Front Panel View	60

Chapter 9. Using AptusNX	74
Figure 34: Mediator Setting for Primary Antenna.....	111
Figure 35: Mediator Setting for Secondary Antenna.....	111
Chapter 12. Appendix	116
Figure 36: Flow Chart of Establishing Dual Antenna System.....	117

Chapter 1. Precautions





1.1 Warnings, Cautions, and Notes

WARNING, CAUTION, and NOTE statements are used throughout this manual to emphasize important and critical information. You must read these statements to help ensure safety and to prevent product damage. The statements are defined below.

	<p>WARNING WARNING indicates a potentially hazardous situation that, if not avoided, could result in death or serious injury.</p>
	<p>CAUTION CAUTION indicates a potentially hazardous situation that, if not avoided, could result in minor or moderate injury. It may also be used to alert users about unsafe practices.</p>
	<p>NOTE A NOTE statement is used to notify people of installation, operation, programming, or maintenance information that is important, but not hazard-related.</p>

1.2 General Precautions

Before you use the antenna, make sure that you have read and understood all safety requirements.

	<p>THIS WAY UP • Place the boxes/crates on the floor with the arrow pointing up.</p>
	<p>FRAGILE • Since the Radome is fragile, handle it with care. Do not apply excessive pressure or shock. These may cause surface cracking or other damage.</p>
	<p>DO NOT STACK • Do not stack boxes/crates as there is a risk boxes/crates may fall and be damaged.</p>
	<p>KEEP DRY • Always make sure the antenna is stored on a dry surface in a dry, well-ventilated area. • The antenna is designed to withstand a normal rain shower; however, water resistance cannot be guaranteed if the antenna is submerged.</p>

* **DO NOT SHIP VIA RAIL:** Ensure not to ship any system via rail.

* **DO NOT STORE THE ANTENNA WRAPPED IN A TARP, TENT, VINYL, OR OTHERS:**

To avoid damage to radome paint, do not use a cover on the radome. Using any type of cover may cause paint damage. Intellian radomes are designed to withstand exposure to rain, humidity, and sun/UV rays when assembled according to Intellian instructions, and when the supplied approved hardware and sealants are used. Under no circumstances should an Intellian radome be covered by any protective covering that adheres, bonds, or clings to the surface, whether by self-adhesion or tension.

Chapter 2. Certifications

FCC Part 15 Subpart B Declaration of Conformity

We, Intellian Technologies, Inc. located at 18-7, Jinwisandan-ro, Jinwi-myeon (Chungho-ri), Pyeongtaek-si, Gyeonggi-do 17709 Korea declare under our sole responsibility that the product(s) described in the below to which this declaration relates is in conformity with the requirement of the FCC Part 15 Subpart B.

Product Information:

Product Name:	Intellian v60Ka 2, 65cm Ka-band Dual Pol Maritime VSAT Antenna System
----------------------	---

Test Result:

Standard	Test	Rule Section	Test Report Number	Result
FCC Part 15 Subpart B	AC Power line conducted emission	FCC Part 15.107(a), ICES-003, Section 3.2.1	DREKFCC2106-0101	Pass
	Radiated emission	FCC Part 15.109(a), ICES-003, Section 3.2.2	DREKFCC2106-0101	Pass

Supplementary Information:

Notified Body Involved: (Testing Organization)	DT&C Co., Ltd. 42 Yurim-ro, 154beon-gil, Cheoin-gu, Yongin-si, Gyeonggi-do, Korea 17042
Technical/Compliance File Held by:	Intellian Technologies, Inc. 18-7, Jinwisandan-ro, Jinwi-myeon (Chungho-ri), Pyeongtaek-si, Gyeonggi-do 17709 Korea
Place and Date of Issue:	Gyeonggi-do, Korea on June 11, 2021

Authority: Kevin Eom
/ CTO, R&D

Signature:  _____

Date: 31th December, 2021

Intellian Technologies, Inc.
US Headquarters
9004 Research Dr.
Irvine, CA 92618 USA
Tel: +1 949 727 4498

Intellian Technologies, Inc.
EMEA & APAC Headquarters
348-5 Chungho-Ri, Jinwi-Myeon
Pyeongtaek-Si, Gyeonggi-Do, 451-862 Korea
Tel: + 82 31 379 1000

Doc Number IT21-DC1231-01

FCC Part 25 Declaration of Conformity

Intellian Technologies, manufactures of stabilized maritime VSAT antenna systems for satellite communication at sea, supplies stabilized maritime VSAT antenna systems to the satellite communication service providers for their ESV (Earth Station on Vessels) networks.

FCC §25.218 defines off-axis EIRP density envelopes for FSS earth stations transmitting in certain frequency bands. This section applies to applications for fixed and temporary-fixed FSS earth stations transmitting to geostationary space stations in the conventional C-band, extended C-band, conventional Ku-band, extended Ku-band, or conventional Ka-band, and applications for ESIMs transmitting in the conventional C-band, conventional Ku-band, or conventional Ka-band, except for applications proposing transmission of analog command signals at a band edge with bandwidths greater than 1 MHz or transmission of any other type of analog signal with bandwidths greater than 200 kHz. Earth station applications subject to this section may be routinely processed if they meet the applicable off-axis EIRP density envelopes set forth in this section. It defines the antennas radiation, and each article regulates the followings;

- §25.218 (i) (1)(3): For co-polarized transmissions in the plane tangent to the GSO arc
- §25.218 (i) (2)(3): For co-polarized transmissions in the plane perpendicular to the GSO arc
- §25.218 (i) (4): For cross-polarized transmissions in the plane tangent to the GSO arc and in the plane perpendicular to the GSO arc

Intellian Technologies, Inc. declares that v60Ka 2 complies with the threshold level as defined in §25.218(i) (1)(2)(4)

Product description	Intellian v60Ka 2, 65cm Ka-band Dual Pol Maritime VSAT Antenna System
EIRP spectral density limit	2.12dBW/Mhz

Radiation pattern data is available upon request to verify the conformance.

Signed by: Kevin Eom / CTO, R&D

Signature:  _____

Date: 31st December 2021

Intellian Technologies, Inc.
 Innovation Center, Global HQ
 18-7, Jinwisandan-ro, Jinwi-myeon (Chungho-ri),
 Pyeongtaek-Si, Gyeonggi-Do, 17709 Korea

Doc Number IT21-DC1231-02

RED Declaration of Conformity

We, Intellian Technologies, Inc. located at 18-7, Jinwisandan-ro, Jinwi-myeon, Pyeongtaek-si, Gyeonggi-do 451-862, Korea declare under our sole responsibility that the product(s) described in the below to which this declaration relates is in conformity with the *essential requirements* and *other relevant requirements* of the Radio Equipment Directive (2014/53/EU).

Product Information:

Product Name(s):	Intellian v60Ka 2, 65cm Ka-band Dual Pol Maritime VSAT Antenna System
-------------------------	---

To provide the presumption of conformity in accordance to Annex III(encompassing Annex II) of Directive 2014/53/EU; the following harmonized standards and normative documents are those to which the product's conformance is declared, and by specific reference to the essential requirements of Article 3 of the Directive 2014/53/EU.

2014/53/EU Article	Standard(s) Applied in Full	Test Report Number	Result
SAFETY (Art 3.1.a)	IEC 62368-1:2020+A11:2020	DRSCEL2106-0102	Pass
EMC (Art. 3.1.b)	EN 301 843-1 V2.2.1	DRECEE2106-0333	Pass
SPECRTUM (Art. 3.2)	EN 301-360 V2.1.1 EN 301-459 V2.1.1 EN 303-978 V2.1.2	DRTCET2106-0238 DRTCET2106-0239 DRTCET2106-0240	Pass

Supplementary Information:

Notified Body Involved: (Testing Organization)	DT&C Co., Ltd. 42, Yurim-ro, 154 beon-gil, Cheoin-gu, Yongin-si, Gyeonggi-do 449-935, Korea
Technical/Compliance File Held by:	Intellian Technologies, Inc. 18-7, Jinwisandan-ro, Jinwi-myeon, Pyeongtaek-Si, Gyeonggi-Do 451-862, Korea
Place and Date of issue:	Gyeonggi-do, Korea on 24 June 2021

Authority: **Kevin Eom**
 / CTO, R&D

Signature: _____ 

Date: _____ **31th December, 2021**

Intellian Technologies USA, Inc.
US Headquarters
11 Studebaker
Irvine, CA 92618 USA
Tel: +1 949 727 4498

Intellian Technologies, Inc.
EMEA & APAC Headquarters
348-5 Chungho-Ri, Jinwi-Myeon
Pyeongtaek-Si, Gyeonggi-Do, 451-862 Korea
Tel: +82 31 379 1000

Doc Number IT21-DC1231-03

UK-CA Declaration of Conformity

We, Intellian Technologies, Inc. located at 18-7, Jinwisandan-ro, Jinwi-myeon, Pyeongtaek-si, Gyeonggi-do 17709, Korea declare under our sole responsibility that the product(s) described in the below to which this declaration relates is in conformity with the *essential requirements* and *other relevant requirements* according to UK legislation Electrical Equipment (Safety) Regulations 2016 (S.I. 2016/1101).

Product Information:

Product Name(s):	Intellian v60Ka 2 65cm Ka-Band Maritime VSAT Antenna System Intellian v85NX Ka 85cm Ka-band Maritime VSAT Antenna System Intellian v100NX Ka, 105cm Ka-band Maritime VSAT Antenna System Intellian v150NX Ka, 150cm Ka-band Maritime VSAT Antenna System
Model Number(s):	V5-60K-U2XX V5-85K-U2XX V5-11K-U2XX V5-15K-U2XX

To provide the presumption of conformity in accordance to Annex III(encompassing Annex II) of Directive 2014/53/EU; the following harmonized standards and normative documents are those to which the product's conformance is declared, and by specific reference to the essential requirements of Article 3 of the Directive 2014/53/EU.

2014/53/EU Article	Standard(s) Applied in Full	Result
SAFETY (Art 3.1.a)	EN 62368-1	Pass
EMC (Art. 3.1.b)	EN 301 843-1	Pass
SPECTRUM (Art. 3.2)	EN 301-360 EN 301-459 EN 303-978	Pass

Authority: Yeonho.Kim
/ CTO, R&D

Signature: 

Date: January 6, 2022

Doc Number IT22-DC0719-06

APAC

Headquarter/Innovation Center
18-7, Jinwisandan-ro, Jinwi-myeon
Pyeongtaek-si, Gyeonggi-do
17709 Korea
T +82 31 379 1000

EMEA

Rotterdam Office
Tempelhof 12
3045 PV, Rotterdam
The Netherlands
T +31 1 0820 8655

AMERICAS

Irvine Office
11 Studebaker
Irvine, CA 92618 U.S.A.
T +1 949 727 4498

Chapter 3. Introduction

3.1 Introduction of v60Ka 2 XCVR

The v60Ka 2 XCVR is Intellian VAST maritime antenna system. The v60Ka 2 XCVR is designed with a compact and light-weight antenna and provides easy and convenient installation in order for user to save total cost of ownership

The v60Ka 2 XCVR provides advanced VSAT solutions for 2.5GHz wide Ka-band satellite services. V60Ka 2 XCVR is equipped with a new mounting architecture RF module. V60Ka 2 XCVR supports dual-polarization and can transmit and receive both LHCP and RHCP of Ka-band circular polarization.

The v60Ka 2 XCVR terminal uses an integral unit of multi-band BUC and LNB arranged in a 4.5W Transceiver. The system with Transceiver can use dual-polarization for both Tx and Rx with several possible topologies. The v60Ka 2 XCVR can be easily upgraded with the 9W High Power Transceiver. There is no need to replace the ACU and no additional components are required. Simply and easy upgrade 9W Transceiver to benefit from high throughput service.

The v60Ka 2 XCVR is operator-friendly and easy to install with a single cable connection combining Tx, Rx, and DC power cables for the data and reference signal transmission between the antenna and Below Deck Units. Installer can connect the cable to the antenna without the process to open the radome by the new radome design with the dome-on external cable connector on the radome.

Using Intellian's next generation antenna control software AptusNX, the v60Ka 2 XCVR antenna can be easily accessed, monitored and controlled. AptusNX is an intuitive configuration tool which is capable to provide enhanced diagnostics of the antenna system and alerts preventive maintenance issues. The Installation Wizard function in AptusNX configures the antenna system automatically and minimizes operators' work for system installation and operation by supporting automatic cable loss compensation, line-up test, and auto diagnostics.

3.2 Features of v60Ka 2 XCVR

Smaller and Lighter

The v60Ka 2 XCVR is the small and light VSAT terminal. It provided easy and convenient installation in order for user to save total cost of ownership. Even though the weight is reduced dramatically, the terminal performance is further improved. And, it still guarantees reliability in harsh sea environments.

2.5GHz Wide Ka-band Support

The v60Ka 2 XCVR has a full range-optimized reflector and radome supporting high-speed Ka-band services, which covers the entire commercial Ka 2.5GHz wide frequency band range. V60Ka 2 XCVR supports dual-polarization and can transmit and receive both LHCP and RHCP of Ka-band circular polarization.

High Power Upgradable

The v60Ka 2 XCVR terminal uses an integral unit of multi-band Transceiver and LNB arranged in a 4.5W Transceiver. The system with Transceiver can use dual-polarization for both Tx and Rx with several possible topologies. The v60Ka 2 XCVR can be easily upgraded with the 9W High Power Transceiver. There is no need to replace the ACU and no additional components are required. Simply and easy upgrade 9W Transceiver to benefit from high throughput service.

Quick & Easy Installation

The v60Ka 2 XCVR is designed to be easy to install and reduce costs for users. The system includes a single cable design, combining Tx, Rx, and DC power into one single solution. The single coaxial cable is connected externally on the base of the radome with no requirement to access the inside of the radome, reducing complexity for the customer during installation and maintenance. The v60Ka 2 XCVR can be accessed through the external connector at the bottom of the radome so that there is no need to open the radome for installation or pre-test.

Embedded Dual Antenna Mediator Function

Intellian's new ACU fully supports dual antenna operation without additional hardware such as a separate mediator, RF splitters and cables. Eliminate loss of signal due to blockage by using dual antenna systems.

AptusNX

Intellian's all new integrated M&C platform AptusNX provides responsive web user interface to manage and control the antenna system regardless of device types. AptusNX performs the real-time data monitoring and alerts preventive maintenance issues by sending warning messages to the NOC when it detects any abnormal operation. The Installation Wizard function in AptusNX configures the antenna system automatically and minimizes operators' work for system installation and operation by supporting automatic cable loss compensation, line-up test, and auto diagnostics.

Chapter 4. Planning Installation

The antenna installation requires extreme precaution and safety measures given its size and weight. Failure to follow the correct installation process may lead to injury of the installer and/or cause damage to the system. To maximize the performance of the system, a thorough review of this installation guide is strongly recommended. In addition, you should execute the installation process as it is noted in this manual.



CAUTION

DO NOT OPERATE THE ANTENNA WITHOUT THE RADOME. THIS WILL RESULT IN DAMAGE TO THE ANTENNA AND ABNORMAL OPERATION.

4.1 Selecting Installation Site

The system should be placed in an area onboard the vessel with little to no RF signal blockage. When the antenna is transmitting, obstacles in the beam path will cause decreased satellite signal strength. The antenna unit should have direct line-of-sight with the desired satellite without any obstacles in the beam path. Minimum distances between the antenna and other onboard devices must also be considered during installation. Install the antenna in accordance with the following procedures to ensure maximum performance.

4.1.1 Minimize Satellite Blockage

The ideal antenna site should have a clear view of the horizon or satellite with all around clearance. Make sure there are no obstacles within the EL range -20° to $+115^{\circ}$ from the center of the antenna. Obstacles can interrupt the satellite signal transmission and reception of the antenna.

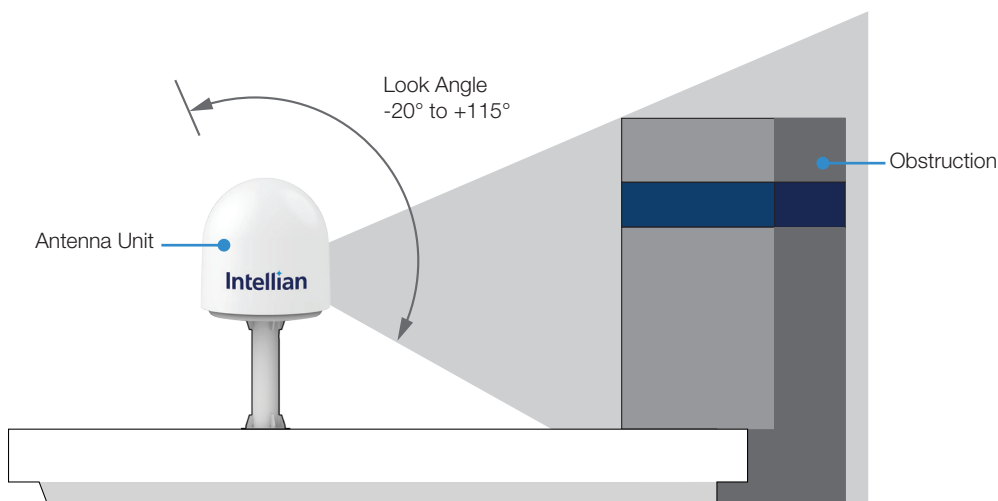

Figure 1: Elevation Limit of Obstacles

4.1.2 Avoid RF Interference

Do not install the antenna near the high power shortwave radar. Most radar transmitters emit RF energy within an elevation range of -15° to $+15^{\circ}$. For this reason, you should position the antenna at least 4.6 m (15.09 feet) away from the radar.

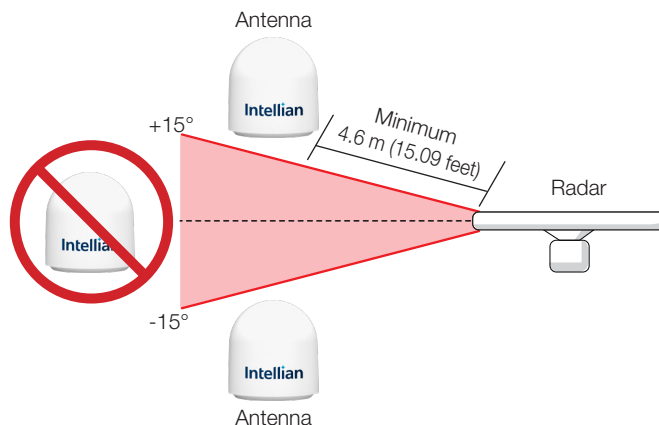

Figure 2: Potential RF Interference



WARNING

Never place the antenna in the beam path of the radar, regardless of distance. The high power shortwave radar may impair its performance or damage the antenna.

4.1.3 RF Hazard Precautions

When the antenna is transmitting there's a potential health risk, as a result of radio frequency (RF) exposure, within the vicinity of the VSAT antenna. The intensity of the RF signal is related to the transmit power, direction and distance to the signal source. In contrary to an omni-directional antenna, the RF transmit signal of a parabolic reflector antenna is concentrated in its direction towards the satellite. Since the antenna is covered with a radome, it's difficult to predict where the antenna is pointed, which could be in any direction within the antenna's range of motion as to the antenna specifications. Although the antenna elevation range is typically down to -20° , it's unlikely for the antenna to transmit at this elevation, while the negative elevation is to compensate for vessel motion. In general, dependent on the satellite link budget, the antenna will have a poor receive signal for a satellite look angle below 10° elevation. In that case when the receive signal threshold is hit, the transmit signal will be blocked, typically referred to as TX mute, on either the modem or antenna. In most situations, the risk of RF exposure is present at lower elevation, corresponding a higher latitude and reduces at higher elevation.

When considering the antenna is typically placed in an area with minimal obstruction and signal interference, an effort should be made to avoid RF exposure as well. It's the responsibility of the antenna owner and/or operator to inform personnel and the general public of the risk of RF exposure. To create awareness, signs should be placed in the potential risk areas. To mitigate the risk of RF exposure, it's suggested to:

- Place the antenna higher up, to avoid the transmit signal reaching work and transit areas.
- Add blockage zones in the ACU for high risk areas of RF exposure.
- Power off the antenna when working in close proximity of the antenna.

While the legislation concerning RF exposure in the country of operation may be different, often reference is made to the ICNIRP guidelines of RF exposure for the occupational and general public scenario. For the frequency range between 6 to 2,300 GHz, the local absorbed power density (Sab) averaged at a 6 minute interval, should not exceed the 5 mW/cm² for occupational and 1 mW/cm² for the general public . The local Sab refers to the power density averaged over a 4 cm² surface area of the human body below 30 GHz and a 1 cm² surface area above 30 GHz.

FCC limits for the maximum permissible exposure (MPE) for the frequency range of 1,500 – 100,000 MHz are set to 5 mW/ cm² for occupational/controlled and 1 mW/cm² for the general population/uncontrolled exposure.

Below table shows the minimum safety distance, with reference to the antenna focal line (Figure 3), of the different BUC configurations based on the FCC limits for occupational and general population exposure. The safety perimeter could be reduced by choosing a more suitable location for the antenna and/or adding blockage zones in the ACU.

Tx Power (W)	Occupational (m/ft)	General Public (m/ft)
	Controlled Exposure R(m), 5.0 mW/cm ²	Uncontrolled Exposure R(m), 1.0 mW/cm ²
9W	14.5/47.6	43.4/142.4

* Main/sub reflector or the feed must avoid contact for all population when the terminal is in transmission.

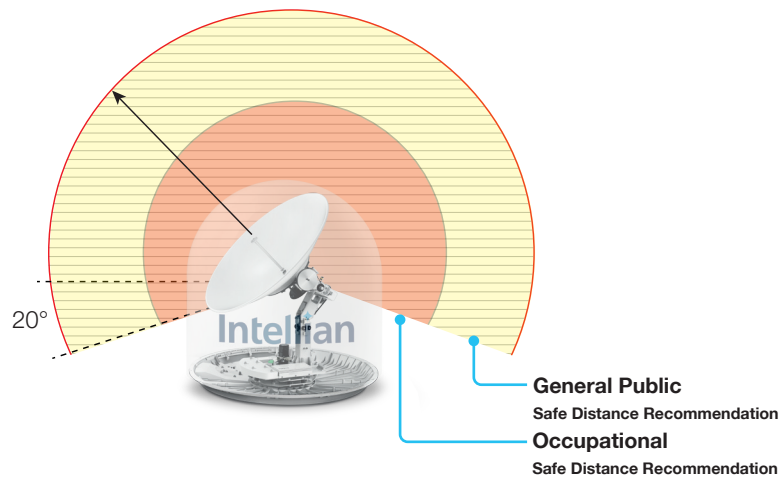

Figure 3: Antenna focal line safety distance

4.2 System Package

4.2.1 Above Deck Unit (ADU)

The ADU includes an antenna pedestal inside a radome assembly unit. The pedestal consists of a satellite antenna main dish with RF components mounted on a stabilized pedestal. The radome protects the antenna pedestal assembly unit from the severe marine environment.



Figure 4: Radome and Pedestal

4.2.2 Antenna Control Unit (ACU)

Antenna Control Unit (ACU) controls Antenna system operation. The following functions are supported by ACU.

- OLED display
- USB port to download logs and upgrade firmware (no PC required)
- Wi-Fi access
- AptusNX web application

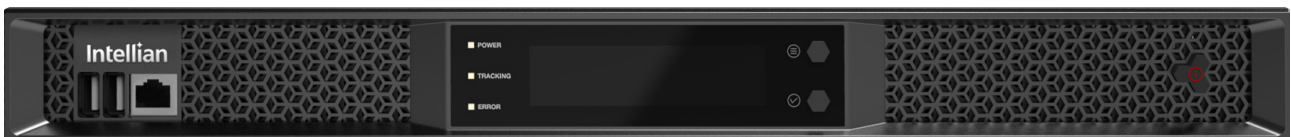

Figure 5: Front Panel of ACU



Figure 6: Back Panel of ACU

4.2.3 Packing List

Before beginning installation, make sure you have all the included components.

Item	Q'ty	Size	Description
Above Deck Unit (ADU)	1		Radome and pedestal
Antenna Control Unit (ACU)	1	431 mm x 350 mm x 44.3 mm	Antenna Control Unit
Quick Installation Guide (QIG)			Installation guide
RF Hazard Sticker	1		Radiation safety distance (30 m) label
Mounting Template	1		Real size drawing of antenna mounting hole pattern
ACU Rack Mount Bracket	2		For installing ACU to 19-inch rack
Flat Head Screw	10	M4 x 12L	For mounting ACU rack mount bracket on ACU
USB Cable (A to A)	1	1.8 m	To connect ACU (front panel left USB port) to PC
AC Power Cord (CEEE7/7)	1	1.5 m	ACU power cord (220 V)
RF Cable (F (M) to F (M))	2	1 m	To connect ACU to modem (Tx / Rx)
Modem Interface Cable (DB-9 (M) to RJ45)	1	1.5 m	To connect ACU to modem (iDirect Modem)
Transceiver Interface Cable (DB-9 (F) to RJ45)	1	1 m	To connect transceiver interface of ACU to transceiver I/O of Modem
Ethernet Cable (RJ45 to RJ45)	2	1 m	To connect ACU to PC network device
Wi-Fi Dongle	1		For Wi-Fi connection
Attenuator	1		10 dB attenuator with DC pass (F type)
Hex Bolt (BUMAX)	5	M12 x 60L	Bolt kit for antenna-deck (mast) assembly (1 spare set included)
Flat Washer (BUMAX)	5	M12	
Spring Washer (BUMAX)	5	M12	
Hex Head Wrench Bolt (Washer Assembled)	5	M6 x 40L	Bolt kit for radome assembly (1 spare set included)
Waterproof Foam	1		With an x-shaped cable hole

4.3 System Cables (Customer Supplied)

4.3.1 Antenna RF Cable (Customer Supplied)

Due to the signal loss across the length of RF coaxial cable on L-Band, use only 50 Ω coaxial cable types for standard system RF cable installation. The use of different type of cables (75 Ω coaxial types, etc.) can cause problems. If you need RF cables that run longer than the maximum cable length recommended, contact Intellian Technical Support for assistance.

Cable Requirements

Coaxial Cable Type	Connector	Max. DC Resistance	Attenuation @ 2 GHz	Max. Cable Length (\leq 16 dB loss @ 2 GHz)
LMR400	N (M) to N (M)	0.8 Ω	0.196 dB/m	60 m
LMR600			0.128 dB/m	100 m

Note:

- Optimal tightening torque for N type RF connector: 1.5 N-m
- Maximum RF loss at 2 GHz: 16 dB including connectors

4.3.2 Gyrocompass Cable (Customer Supplied)

The following general types of gyrocompass cables are recommended for compatible connection to Intellian antennas used in various vessel environments.

Standard	NMEA 2000	NMEA 0183
Connector Type	Micro-C 5 pin connector	2 pin terminal block connector
Cable Type	5-wire single cable	2-wire cable with one enclosed shield cable
Heading Information	Supports PGN, 127250: Vessel Heading	Supports \$HEHDT, baud rate 4800, format 8N1 as standard

4.4 Unpacking System Package



CAUTION

- The package box on the pallet should be lifted by a forklift.
- Follow the steps in order for easy and safe unpacking.

1. Position the "FRONT" marked side of box to the front, then remove all the plastic straps securing the box to the pallet using a cutter.
2. Open the top cover.

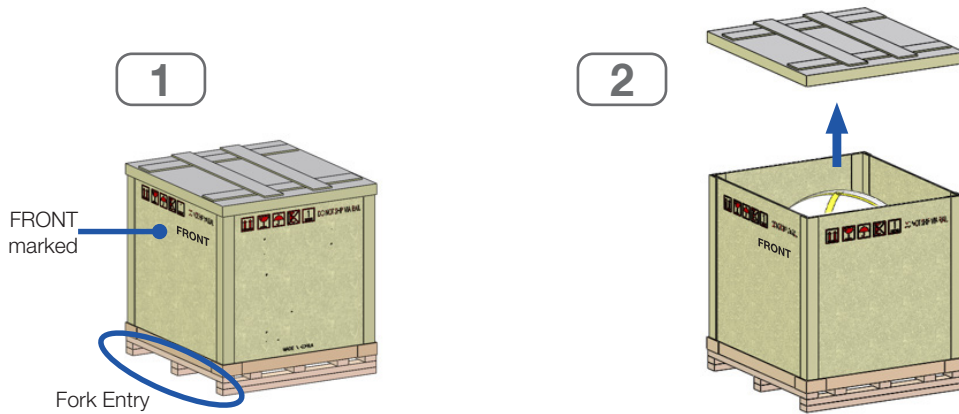

3. Lift up and remove the "FRONT" marked panel.
4. The ACU Box is located inside the side panel. Take out the box by both hands.

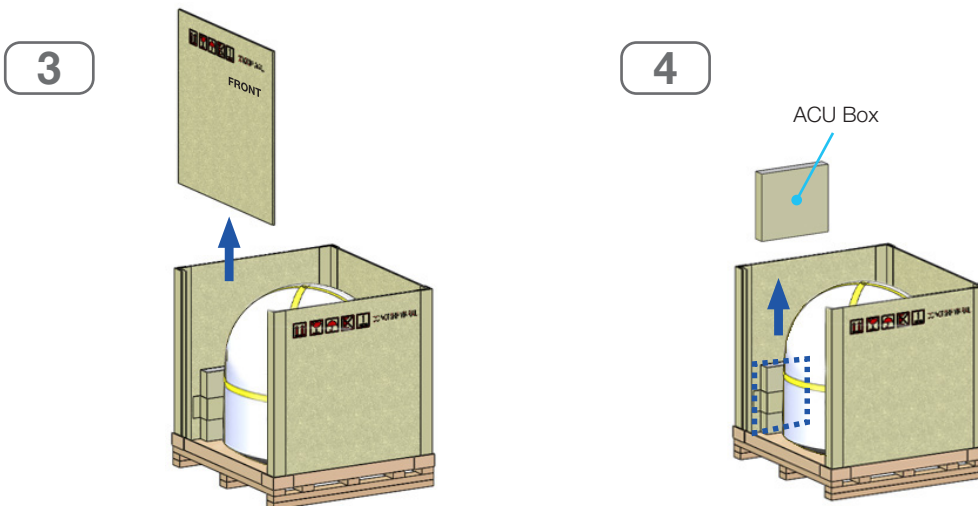

5. Lift up and remove the rest of the side panels.

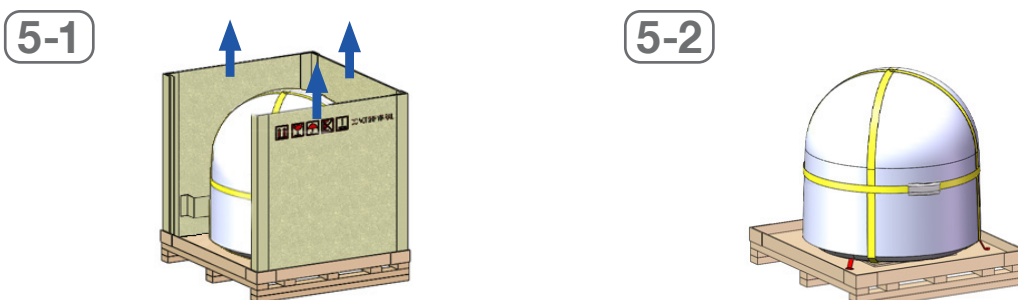

Chapter 5. Installing Above Deck Unit (ADU)

5.1 Antenna Dimensions

Before installing the antenna unit, confirm its height and diameter (see figure below). The mounting surface and overall space occupied by the antenna must be sufficient for the fully constructed radome on top of its base frame. Using a crane during the antenna installation is strongly suggested.

Unit: mm (inches)

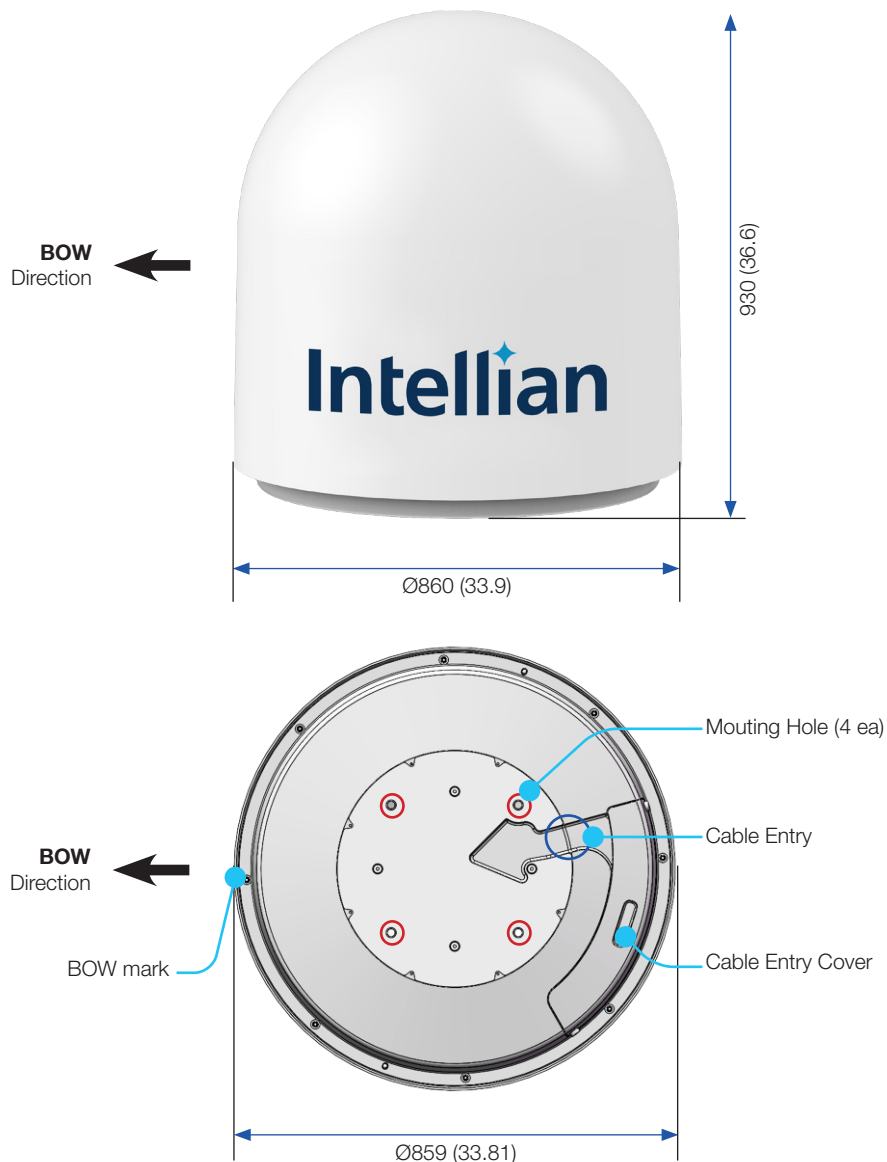

Figure 7: Antenna Dimensions



NOTE

Position the antenna with the BOW direction parallel to the center line of the ship.

5.2 Antenna Mounting Hole Pattern

Use the supplied mounting template when drilling mounting holes on the mast. The hole placement for the antenna must match the mounting hole pattern on the template.



WARNING

When reusing an existing mast, make sure the location of the holes on the mast correspond to the hole locations and sizes printed on the mounting template.

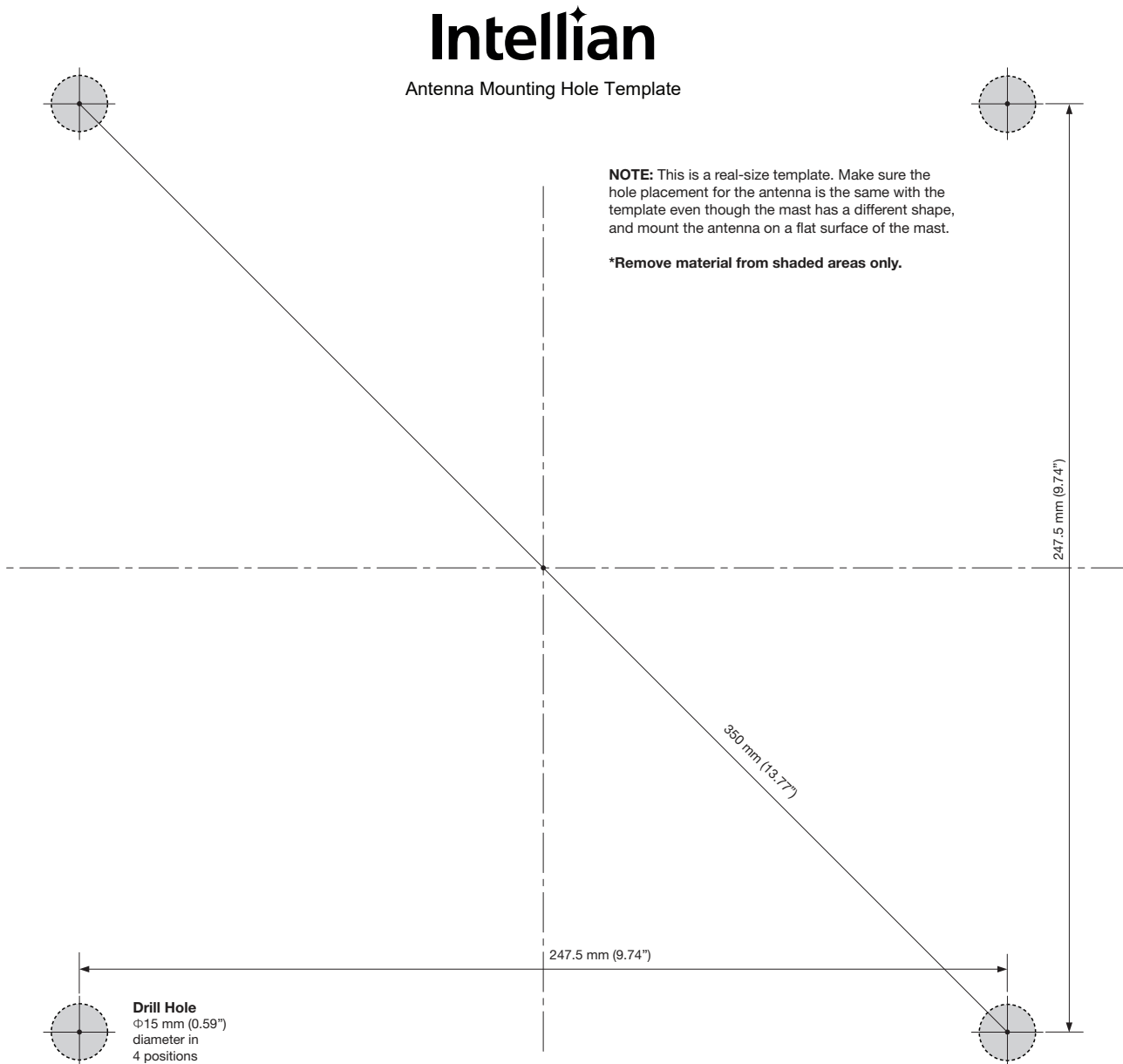

Figure 8: Antenna Mounting Hole Template

5.3 Designing Mast (Example Only)

The installation mast must be robust enough to prevent flex, vibration, and sway when an external force is exerted on the mast with antenna and radome attached. Refer to the following mast drawings for more details.



NOTE

This is a general example of designing a mast. The shape of mast may differ depending on the ship's environment.



WARNING

- When designing a mast, consider the minimum and maximum thickness of the mast plate marked on the diagram. If the thickness of the mast plate is different from the recommended size (Min. 10.0 mm/ Max. 15.0 mm), choose the bolt size for mounting the antenna on the mast according to the table below.

Mast Plate Thickness	Recommended Bolt Size
5 ~ 12 mm	M12 x 55L
10 ~ 17 mm (Recommended)	M12 x 60L (Supplied)
15 ~ 22 mm	M12 x 65L
20 ~ 27 mm	M12 x 70L
25 ~ 32 mm	M12 x 75L

- To use the supplied bolts (M12 x 60L) for mounting the antenna on a mast, the thickness of the mast plate must be 10 ~ 15 mm. **A** If the mast plate is thinner than 10 mm, the bolt thread stick-out protruding beyond the nut inside the radome can damage the AZ belt of the antenna. **B** If the mast plate is thicker than 15 mm, the supplied antenna mast mounting bolts may be too short to mount the antenna on the mast securely.

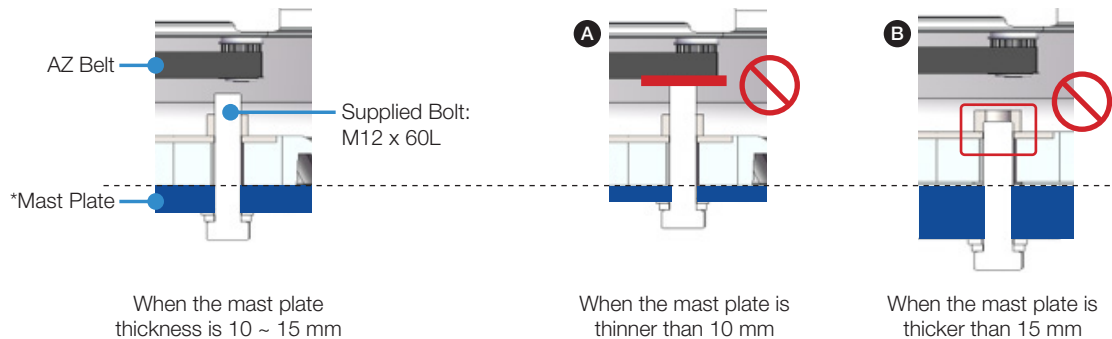

Option 1. When Installing Cable on Outside of Mast

This method is generally recommended.

Unit: mm (inches)

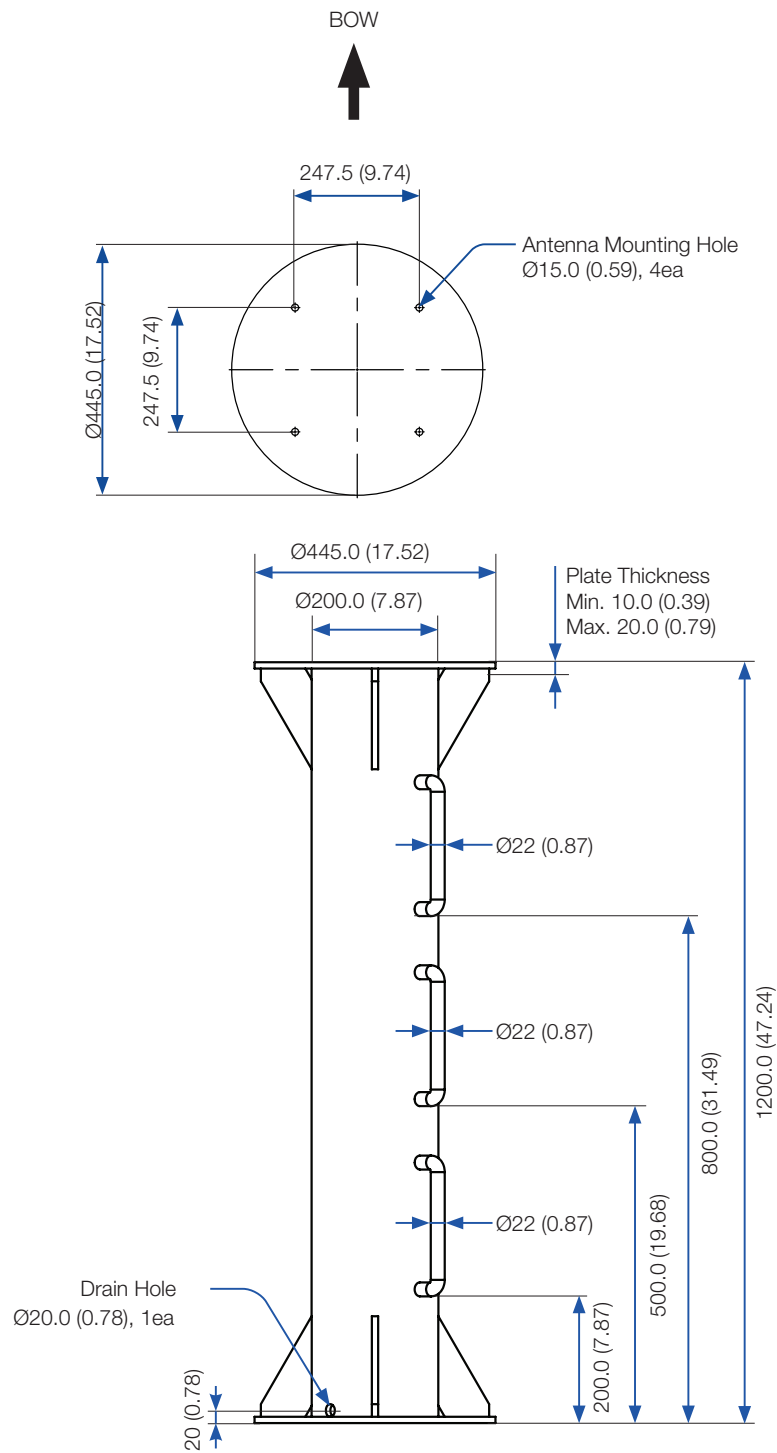

Figure 9: Recommended Size of Mast (Option 1)

Option 2. When Installing Cable Through Inside Mast

Unit: mm (inches)

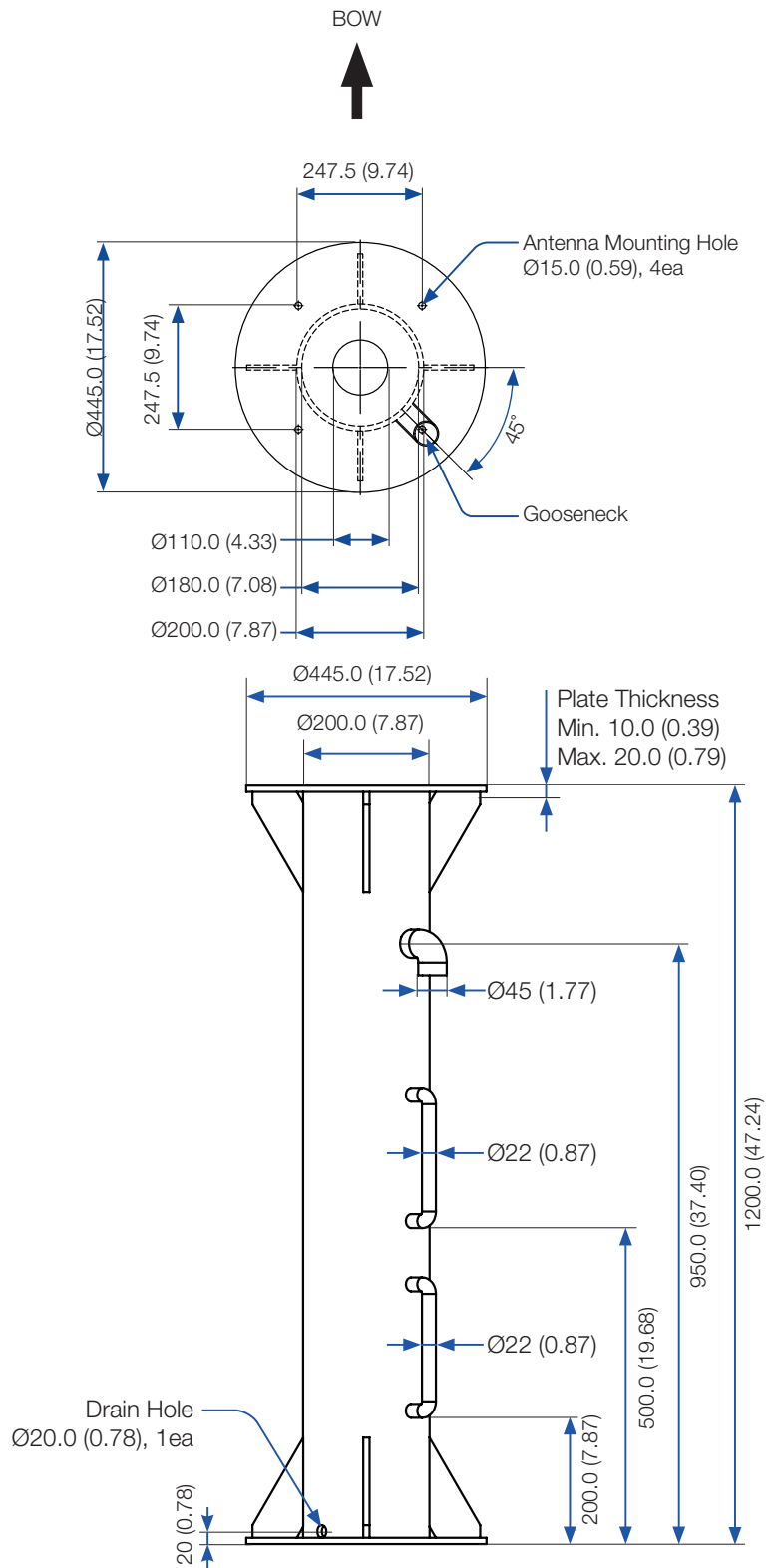

Figure 10: Recommended Size of Mast (Option 2)

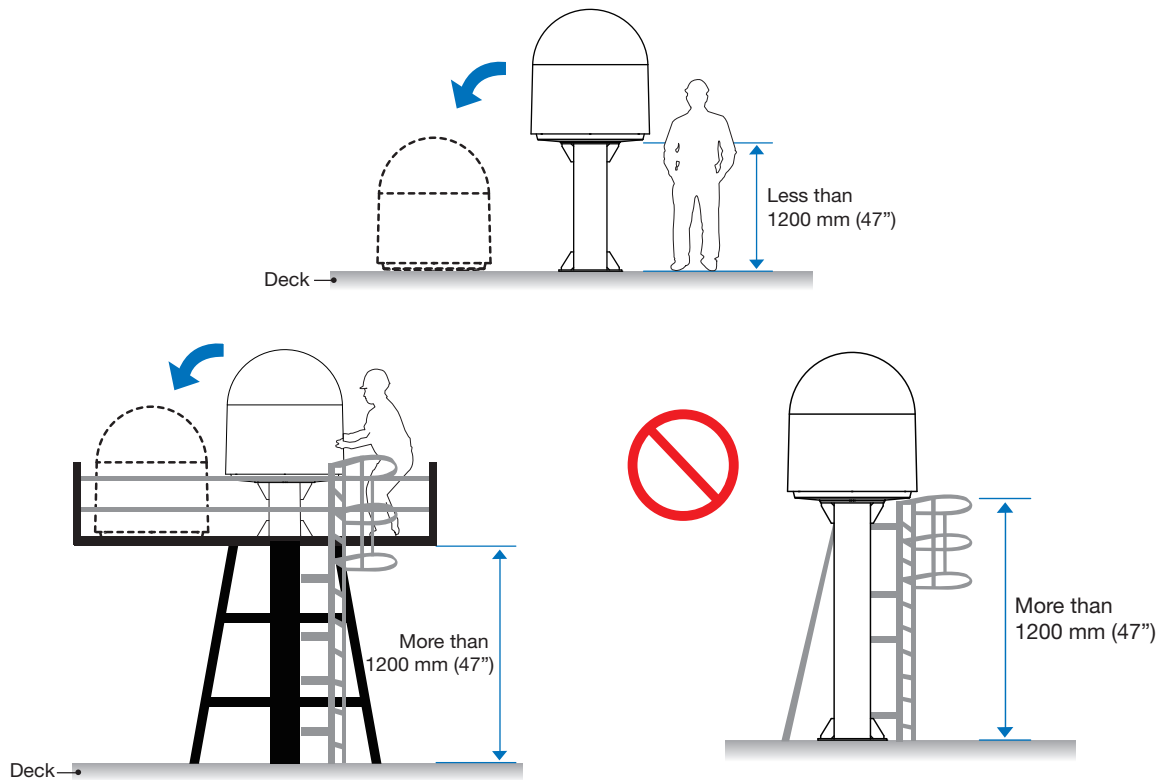

Figure 11: Recommended Size of Mast (Option 2)



WARNING

Intellian strongly recommends installing the antenna less than 1200 mm (47") above the deck for safe access and maintenance. When installing the antenna more than 1200 mm (47") above the deck, make sure to have enough working space around the mast for the installers to move around and put the radome down.

5.4 Routing RF Cable on Mast (Example Only)

The cable must be routed from the antenna and through the ship to end up at the antenna control unit. When pulling the cable in place, avoid sharp bends, kinking, and excessive force. After placement, seal the deck penetration gland and tie the cable securely in place. Cable brackets must be installed on the mast to secure the cable. The gooseneck must be installed on the side of the mast to protect the cable from water.



WARNING

Ensure that cable has been run through watertight fittings to prevent water entry into the vessel when installation is completed.



NOTE

This is a general example of routing cables on the mast. The routing method may differ depending on the ship's environment.

Option 1. Routing Cable on Outside of Mast

This method is generally recommended.

1. Route the cable from the gooseneck on the deck to the antenna as shown in the picture.
2. Maintain a sufficient cable length (at least 2 m) when routing the cable on the surface of the mast. After connecting the cable to the connector on the radome, adjust the length and fix the cable on the cable brackets using cable ties.

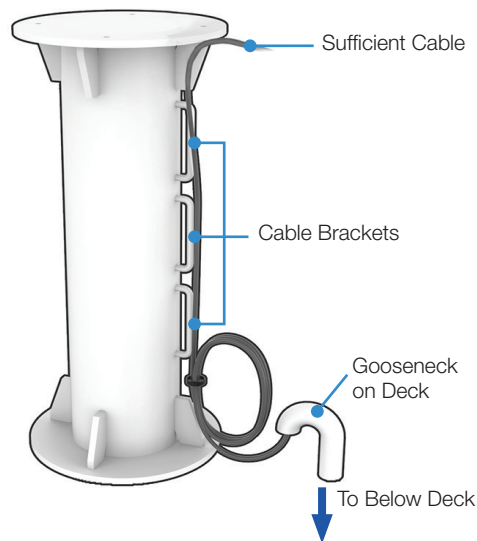

Figure 12: Routing Cable Through Outside of Mast

Option 2. Routing Cable Through Inside Mast

1. Before placing the radome on the mast, route the cable through the gooseneck on the deck and the built-in gooseneck on the mast for easier placing of the RF Cable through the inside of the mast as shown in the picture.
2. Maintain a sufficient cable length (at least 2 m) when routing the cable on the surface and inside of the mast. After connecting the cable to the connector on the radome, adjust the length and fix the cable on the cable brackets using cable ties.

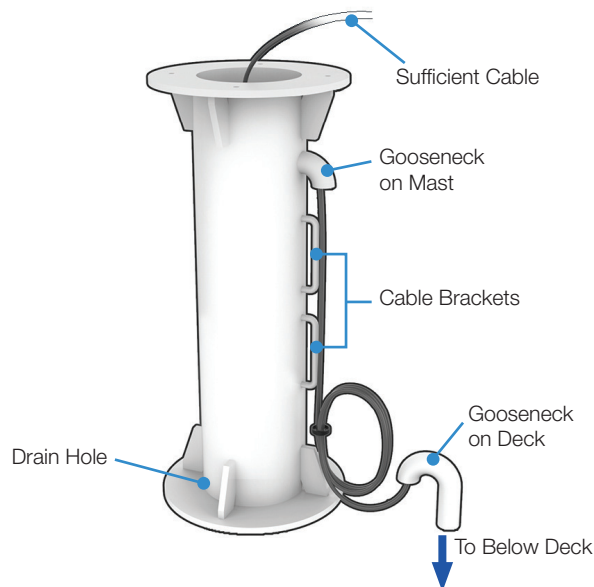

Figure 13: Routing Cable Through Inside of Mast



CAUTION

Do not leave the cables on the top surface of the mast. When putting down the antenna on the mast, there is a risk of damage to the cable connector if the cable is located on the top surface of the mast.

5.5 Removing Antenna from Wooden Pallet

Four radome brackets secure the antenna to the pallet. To remove the radome from the pallet and the brackets from the radome, use the following procedure.

1. Remove the fixing screws (2 ea) that secures the radome bracket on the pallet using a wrench.
2. Loosen and remove the radome bolt (1 ea) that secures the radome bracket on the radome by turning it counter-clockwise with a wrench. Then remove the radome bracket from the radome.
3. Find the supplied Hex Head Wrench Bolts (M6 x 40L), Spring Washers, and Flat Washers from the ACU box. Apply Loctite #243 on the bolt, and assemble the bolt and washers to the radome by turning it clockwise using a wrench. **DO NOT** reuse the removed bolt and washers.

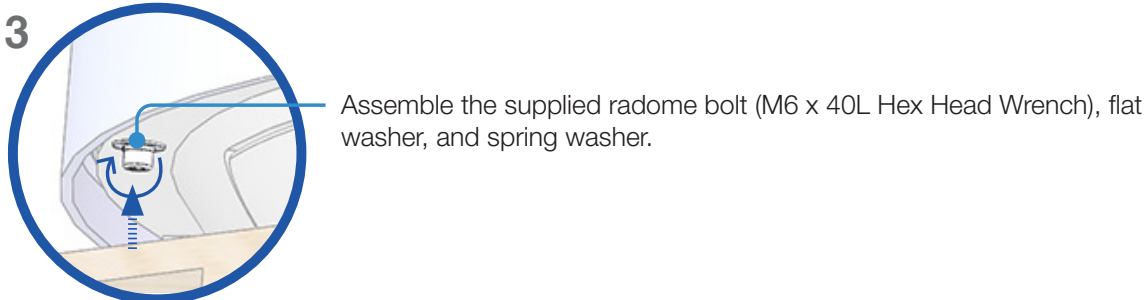
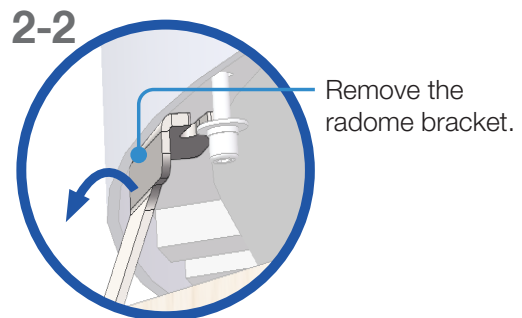
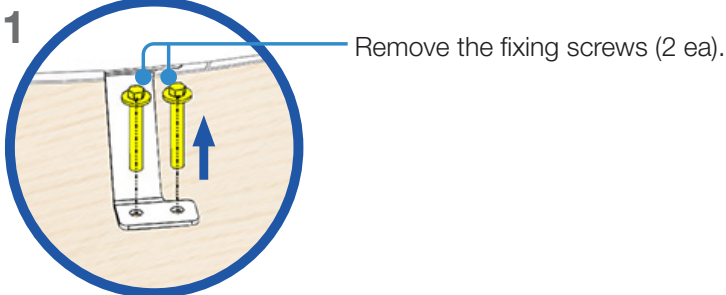
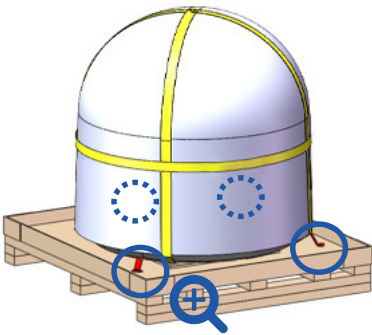

CAUTION

- Fully tighten the radome bolt.
- Use the radome bolt and washers supplied in the ACU box.
- **DO NOT** reuse the removed bolt and washers.

- Repeat the procedure to remove all four radome brackets.
- Check the condition of lifting strap to make sure the shackles (1 ea) are tightened. After checking the shackles, re-wrap them with the existing protection to avoid radome damage.

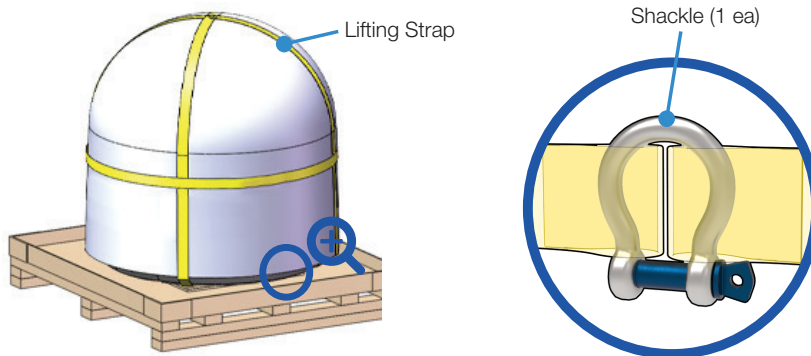
**WARNING**

Make sure to remove the radome brackets that secure the radome to the pallet before lifting the antenna using the lifting straps.

5.6 Moving Antenna Above Mast

The Intellian antenna comes from the factory with the lifting straps pre-mounted.

- Check the condition of the lifting strap and ensure the shackles are tightened up.
- Lift the antenna above the mast using a crane and carefully lower down the antenna toward the mast. Maintain sufficient space (at least 150 mm) between the bottom of radome and the mast for cabling work.

**WARNING**

The antenna may sway in the wind when suspended by a crane. Be careful when handling the antenna.

**NOTE**

Position the antenna with the BOW direction parallel to the center line of the ship.

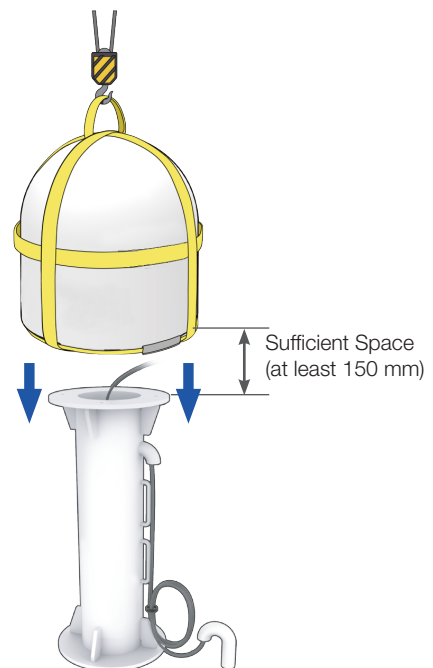

5.7 Inserting Waterproof Foam

The supplied waterproof foam must be inserted to prevent water penetration into the radome before mounting the radome on the mast. Make sure the waterproof foam is positioned where the following picture shows.

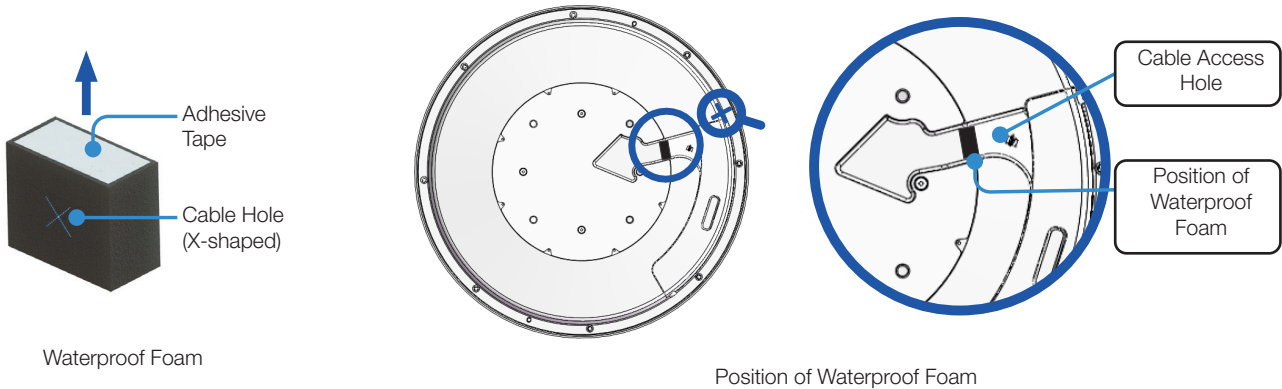

Option 1. When Installing Cable Through Inside Mast

1. Peel off the paper backing of the adhesive tape from the waterproof foam.
2. Extend the RF cable up to the radome from the mast, and pass the cable through the cable hole (X-shaped) of the waterproof form.
3. Then attach the adhesive side of waterproof foam firmly onto the surface of the cable access hole. When moving the radome, be careful with the waterproof foam and cable not to be detached.

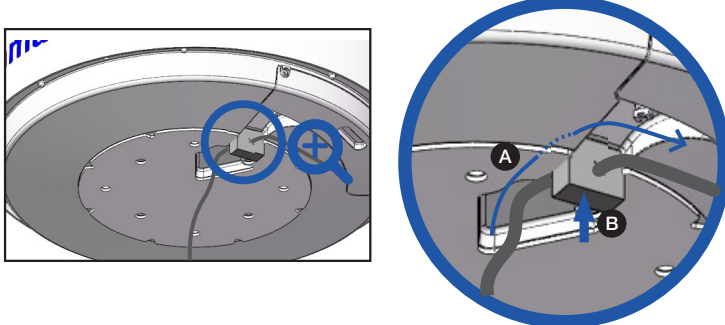

Option 2. When Installing Cable on Outside of Mast

1. Peel off the paper backing of the adhesive tape from the waterproof foam.
2. Attach the adhesive side of waterproof foam firmly onto the surface of the cable access hole.
3. Extend the RF cable up to the radome from the mast.

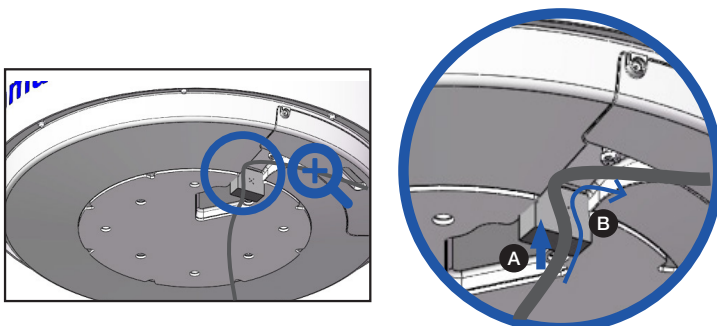

5.8 Mounting Antenna on Mast

1. Bring the M12 x 60L hex bolts (4 ea) for antenna-mast assembly from the ACU box.
2. Lower the antenna onto the mast using the crane, making sure the mounting holes of the antenna are aligned with those of the mast. Make sure the cable from the mast is aligned with the cable entry on the bottom of the antenna for stable connection.
3. Apply Loctite #263 to the bolt threads, insert the bolts and washers from under the mast into the built-in nuts on the bottom of the radome (see Figure 15), and then lightly tighten them by hand. Use a crisscross sequence as shown in Figure 14.
4. After installing all 4 bolts, fully tighten the bolts using a torque wrench in the crisscross sequence. Refer to **"12.1 Appendix A. Tightening Torque Specification"** on page 116 for the bolt tightening torque.
5. Remove the lifting strap from the antenna.

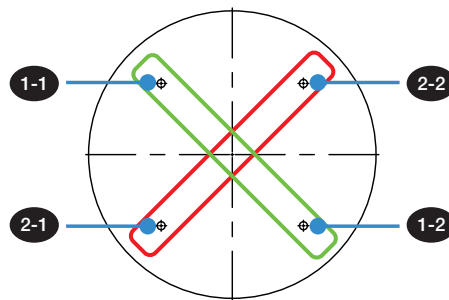

Figure 14: Installing Sequence of Bolts

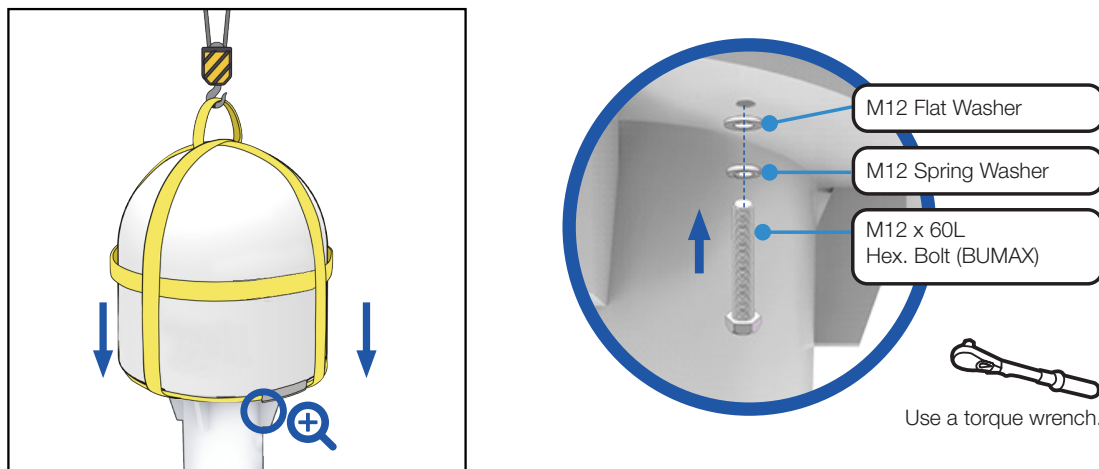

Figure 15: Installing Bolts for Antenna-Mast Assembly

NOTE



- Make sure the cable from the mast is aligned with the cable entry on the bottom of the antenna for a stable connection.
- Refer to **"12.1 Appendix A. Tightening Torque Specification"** on page 116 for the bolt tightening torque.

WARNING



If a bolt does not fit into the mounting hole when installing the bolt by hand, stop installing and check the bolt size. **DO NOT** tighten the bolts forcefully. Forceful tightening can damage the inner threads of the antenna mounting holes. This type of damage is not covered by the warranty.

5.9 Connecting RF Cable to Antenna

Connect the RF Cable (Customer Supplied) from the ANTENNA port of the ACU to the RF connector inside the cable entry of radome. Both side of the connection cable should be terminated using suitable tools. After the connection, securely fix the cable in place using cable ties.



NOTE

Make sure of the following before installing system cables.

1. All cables need to be well clamped and protected from physical damage and exposure to heat and humidity.
2. Don't use any acutely bent cable.
3. Use watertight glands or swan neck tubes at exposed bulkheads or deck heads where the cable passes through.
4. Install recommended size cables. Refer to "**4.3 System Cables (Customer Supplied)**" on page 20 for see cable requirements.

1. Remove the M4x15L Wrench Bolt by using the wrench set then open the cable entry cover.

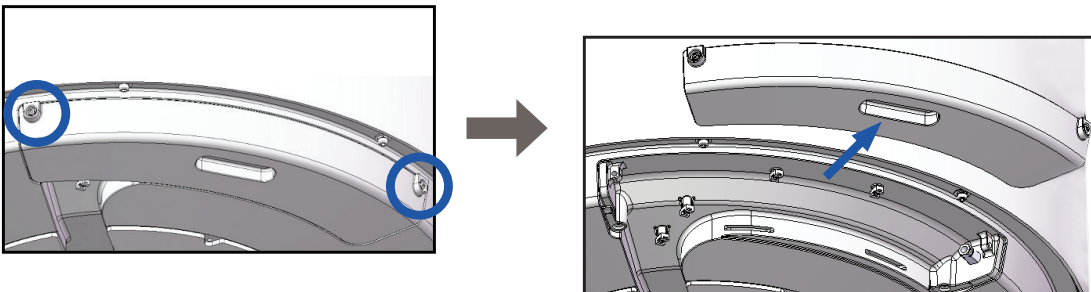

NOTE

Keep the detached cover in a safe place for later use.

2. Terminate N(M) connector on the end of the RF Cable. Intellian recommends using a genuine cable connector and tools. Refer to the cable termination instructions provided by the manufacturer to terminate the N connector.
3. Connect the terminated RF cable to the connector of the radome as the following. Ensure the cable is firmly fastened to the connector. Fix the cable position along the routing path using cable ties, cable mounts or cable clamps.

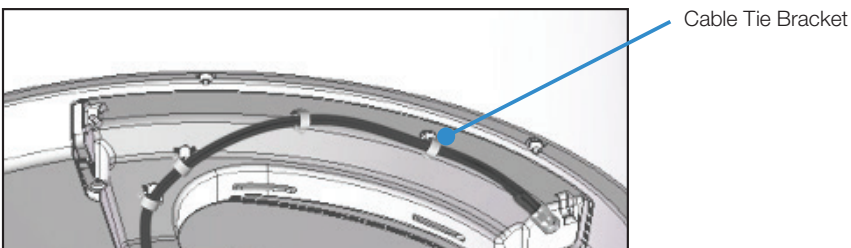

4. After completing cable connection, put the cover in the right place and close it by tightening the M4 x 15L wrench bolts (2 ea) by using a wrench set.

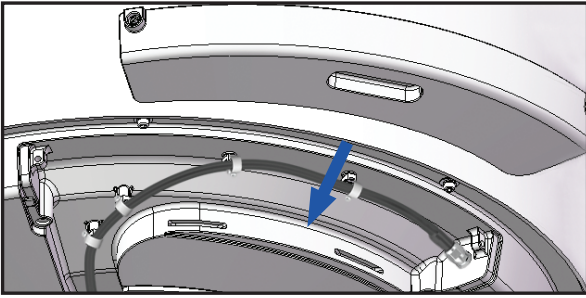

Chapter 6. Installing Below Deck Unit (BDU)

6.1 Selection of BDU Installation Site

The ACU should be installed below the deck in a location that is dry, cool and ventilated. The front panel of ACU should be easily accessible to users.

6.2 ACU Dimensions

Confirm the dimensions of the ACU before installing it.

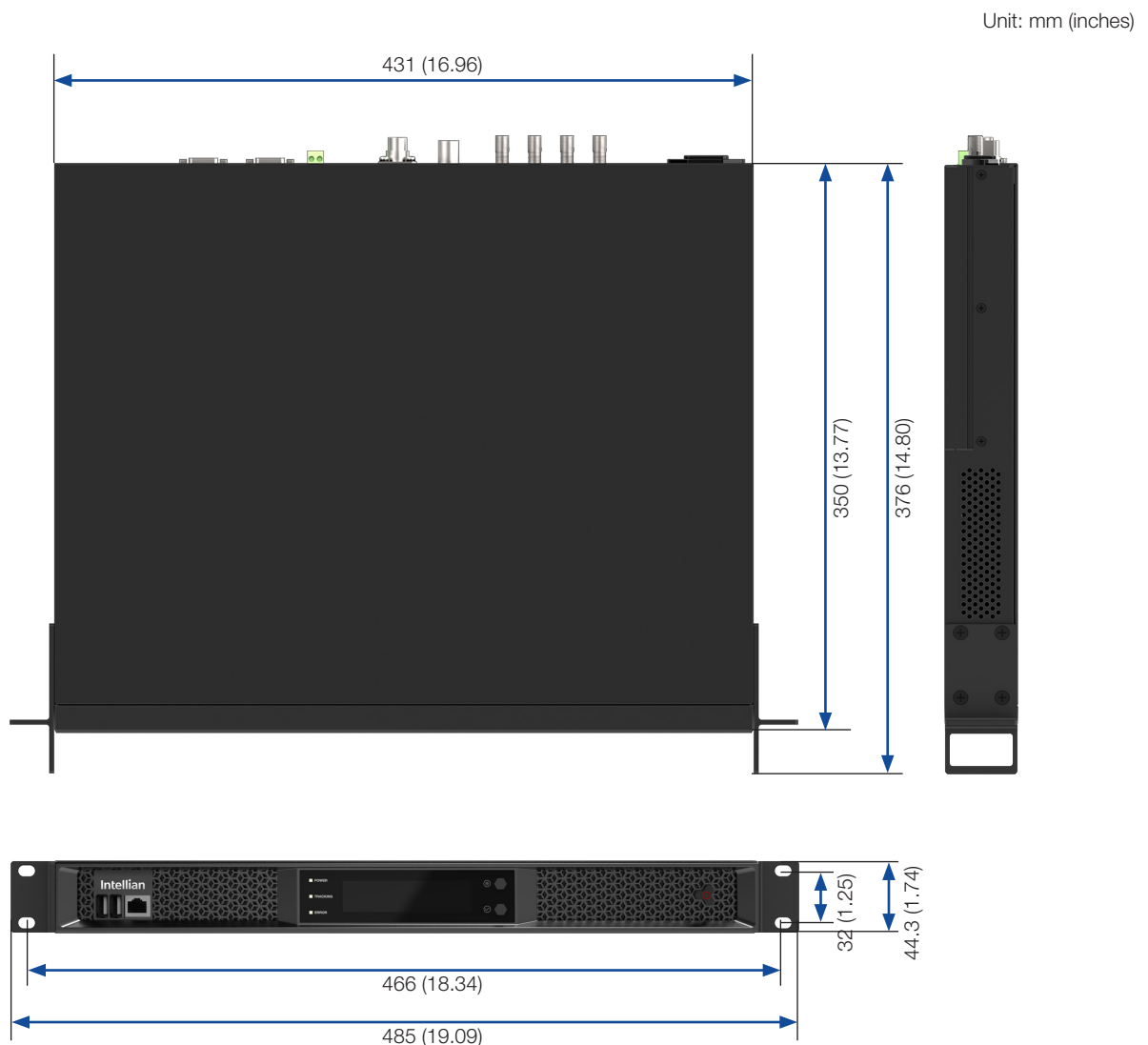

Figure 16: ACU Dimensions

6.3 Mounting ACU

Mounting ACU in a 19" Rack

The ACU can be installed in a 19" rack using the two rack mount brackets that are included in the ACU box. Attach the rack mount brackets to the sides of the ACU using the included M4 x 12L flat head screws (8 ea). Connect cables to the back side of the ACU.



Figure 17: 19-inch Rack Mounting ACU



WARNING

Ensure that the cables connected to the ACU are long enough to prevent damage when the ACU is pulled out from the rack.

6.4 Antenna System Configurations

For the proper operation of the satellite communication system, the required components must be connected as shown in the figure. Separate purchase of a satellite modem, switch router and ship's gyrocompass may be needed.

6.4.1 Single Antenna System Configuration (Basic Antenna System)

The basic system consists of one VSAT antenna and one ACU. As shown in the configuration, connect the cables correctly.

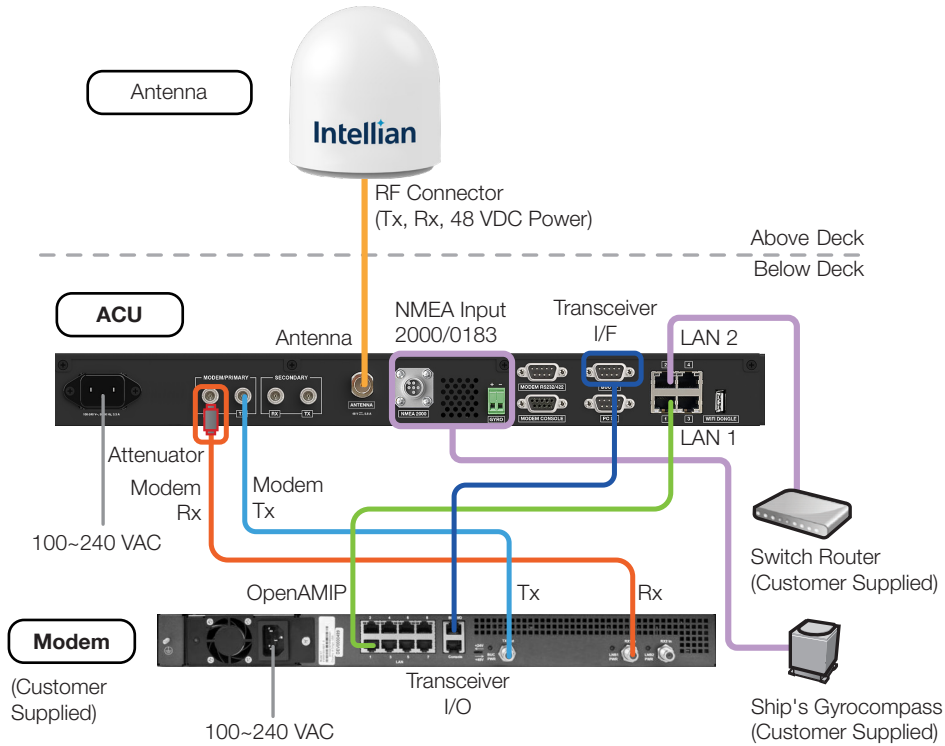
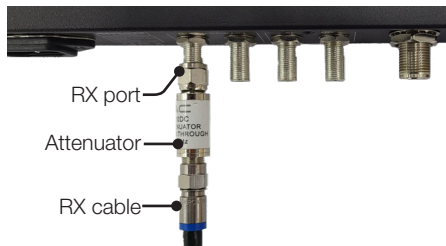

Figure 18: Single Antenna System Configuration



NOTE

Make sure that the attenuator in the ADU bolt kit box must be connected between RX port on the ACU and Rx cable.



6.4.2 Dual Antenna System Configuration (Optional)

The dual system consists of two VSAT antennas and two ACUs. The ACUs have embedded Dual Antenna Mediator function, which is capable of controlling and managing two VSAT antenna systems simultaneously. As shown in the configuration, connect the cables correctly.

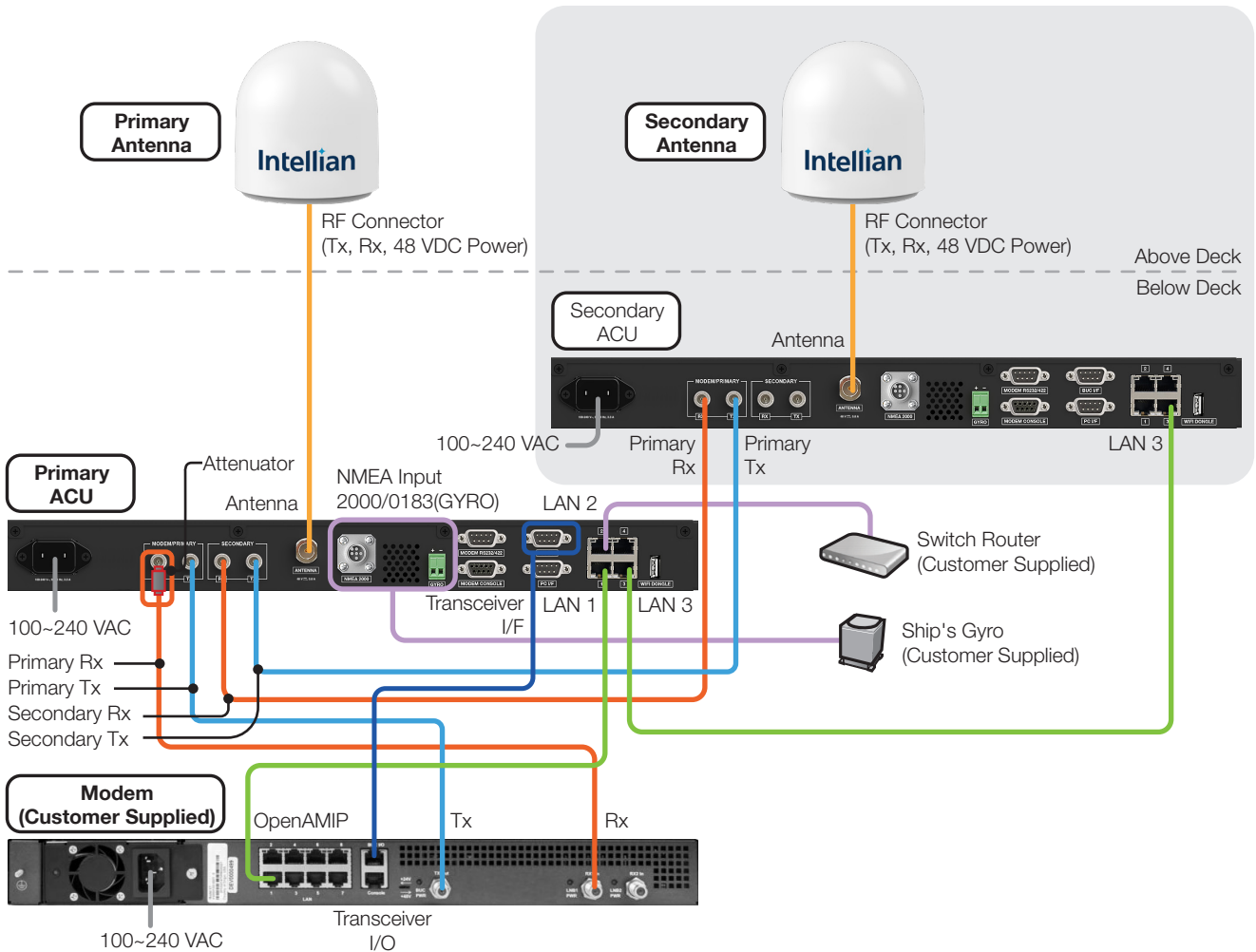

Figure 19: Dual Antenna System Configuration

6.5 ACU Cable Connection

6.5.1 ACU Back Panel Connectors

The following figure shows the ACU back panel connectors.

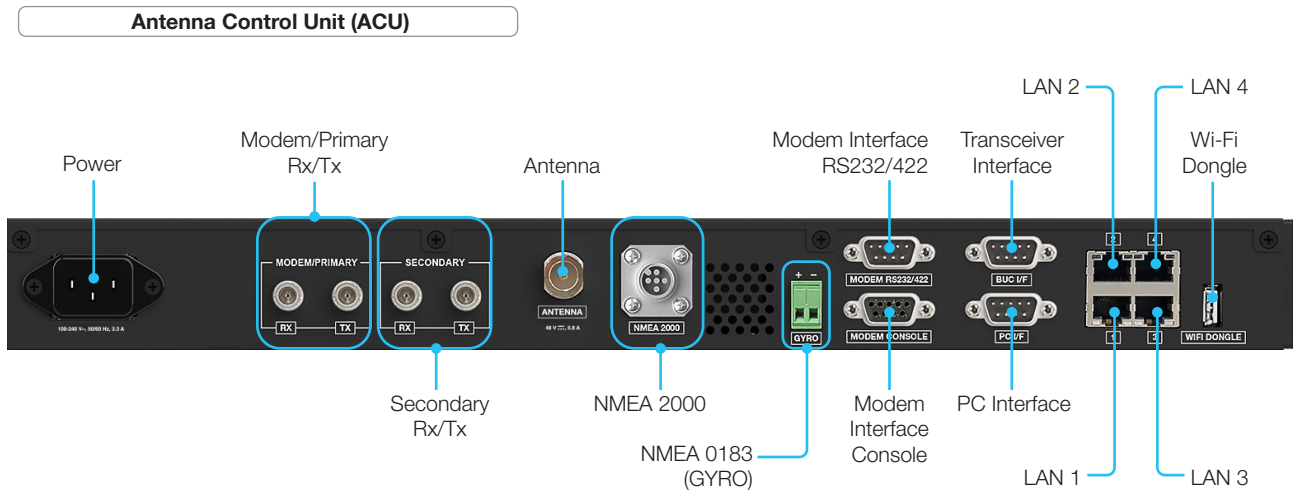
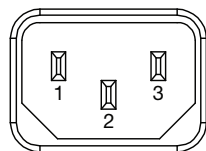

Figure 20: ACU Back Panel Connectors

6.5.2 ACU Connector Pinout Guide

Reference the following connector pinout information for the connection ports of the ACU.

Power Connector



IEC 320 C14 Plug Male

Pin	Signal
1	NEUTRAL
2	GND
3	LIVE

Modem Primary / Secondary Tx and Rx Connectors

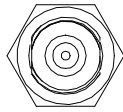

RF F Type Female

Conductor	Function
Inner	DATA
Outer	GND

Antenna Connector

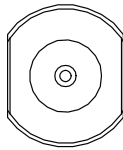

RF N Type Female

Conductor	Function
Inner	RX, TX, FSK, REFERENCE, POWER
Outer	GND

NMEA 2000 Input

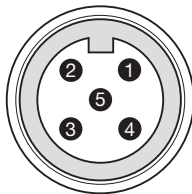

Micro-C 5-Pin Male

Pin	Signal
1	N/C
2	N/C
3	N/C
4	NET-H (CAN-H)
5	NET-L (CAN-L)

NMEA 0183 Input

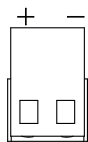

2-Pin Terminal Block

Pin	Signal
+	HEADING IN
-	HEADING GND

Modem Interface - RS232 & RS422 Connector

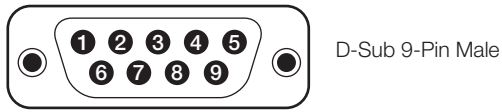

Pin	Signal
1	N/C
2	MODEM TX / MAX422 RX+
3	MODEM RX / MAX422 TX+
4	N/C
5	GND
6	N/C
7	MAX422 RX-
8	MAX422 TX-
9	N/C

Modem Interface - Console Connector



Pin	Signal
1	GND
2	GPS_OUTA
3	MODEM_LOCK
4	MUTE 0
5	N/C
6	GPS_OUTB
7	EXM_AGC
8	MUTE 1
9	N/C

Transceiver Interface - RS422 Connector

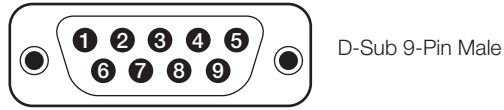

Pin	Signal
1	Transceiver RS422 RX+
2	Transceiver RS422 RX-
3	Transceiver RS422 TX+
4	GND
5	GND
6	Transceiver RS422 TX-
7	Transceiver KEYLINE RX+
8	Transceiver KEYLINE RX-
9	N/C



NOTE

Use the supplied Transceiver Interface Cable (D-Sub to RJ45) to connect between RS422 port of the ACU and Transceiver I/O port of the modem.

PC Interface - RS232 Connector



Pin	Signal
1	N/C
2	PC RX
3	PC TX
4	N/C
5	GND
6	N/C
7	IARM TO PC_DBG_TX
8	PC TO IARM_DBG_RX
9	N/C

ETHERNET (LAN) Connector (LAN 1~LAN 4)

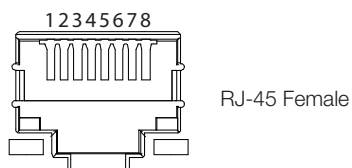

Pin	Signal
1	TX-
2	TX+
3	RX-
4	N/C
5	N/C
6	RX+
7	N/C
8	N/C

Wi-Fi Dongle USB Connector

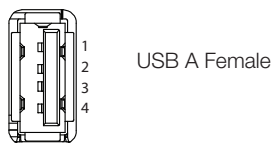

Pin	Signal
1	+5 V
2	DATA-
3	DATA+
4	GND

6.5.5 Connecting ACU to Antenna in Dual Antenna System (Optional)

For the Dual Antenna System, the antenna system needs to be installed with two ACUs and two antennas.

1. Connect an **Antenna RF cable (N to N)** (Customer Supplied) from the **ANTENNA (N)** port of the Primary ACU to the **RF (N)** port of Primary Antenna.
2. Connect another **Antenna RF cable (N to N)** (Customer Supplied) from the **ANTENNA (N)** port of the Secondary ACU to the **RF (N)** port of Secondary Antenna.

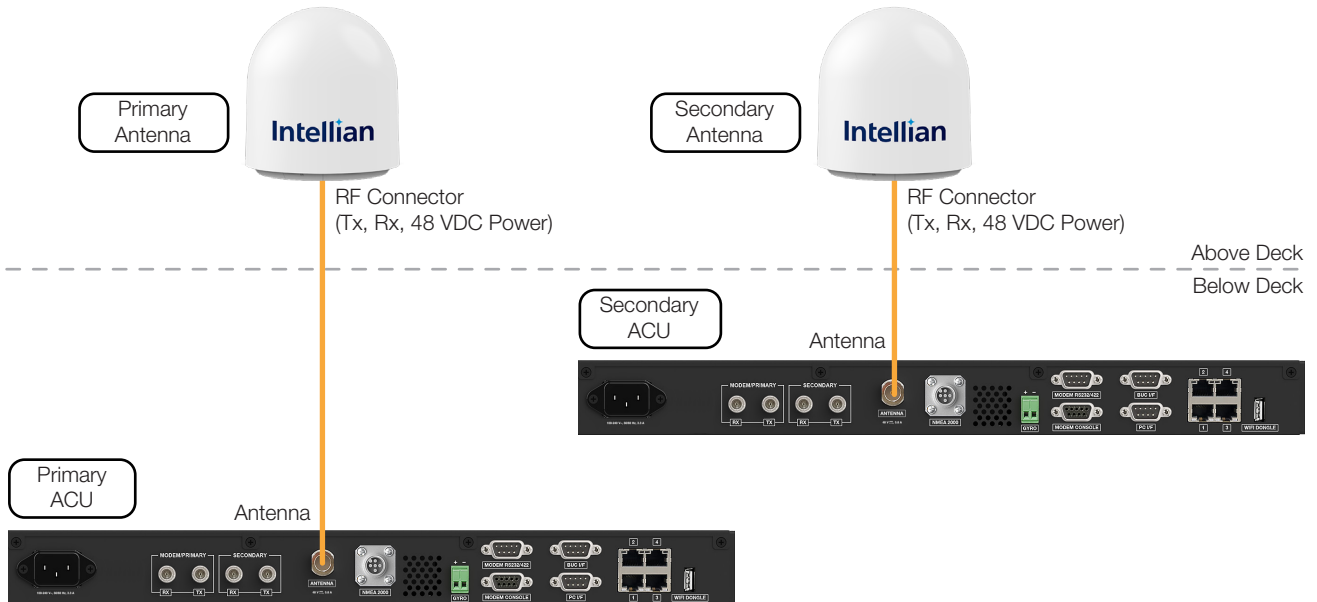

Figure 23: ACU to Antenna Cable Connection for Dual Antenna System

6.5.6 Connecting Primary/Secondary ACUs in Dual Antenna System (Optional)

For the Dual Antenna System, the antenna system needs to be installed with two ACUs and two antennas.

1. Connect a **RF cable (F to F)** from the **Secondary Rx (F)** port of the Primary ACU to the **Primary Rx (F)** port of Secondary ACU.
2. Connect another **RF cable (F to F)** from the **Secondary Tx (F)** port of the Primary ACU to the **Primary Tx (F)** port of Secondary ACU.
3. Connect an **Ethernet cable** between the **LAN 3 (RJ45)** ports of each Primary and Secondary ACUs.

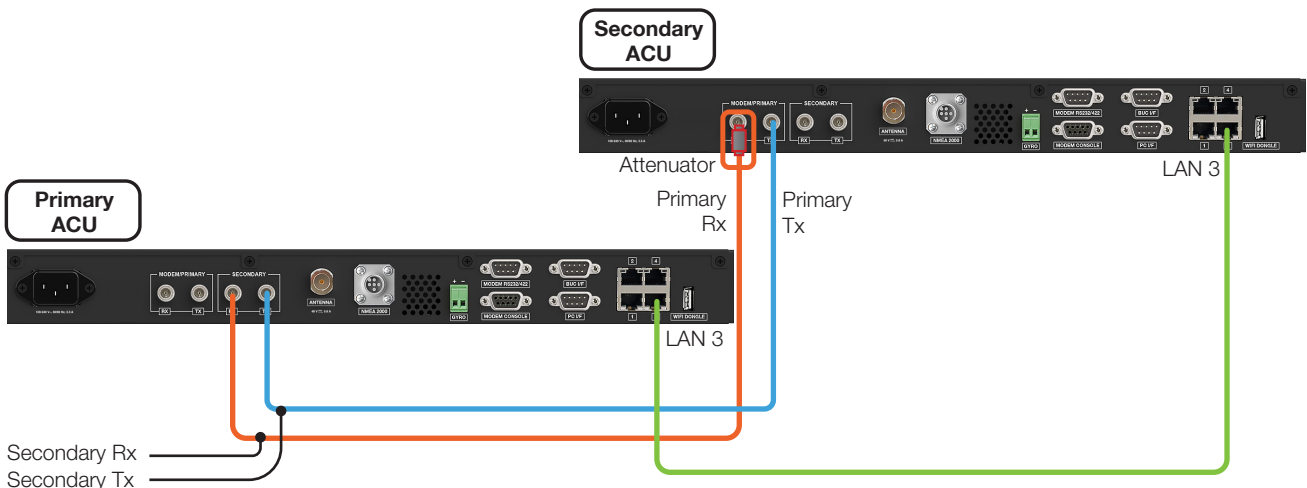

Figure 24: Primary and Secondary ACU Cable Connection in Dual Antenna System

6.5.7 Connecting ACU to Modem

1. Connect a **RF cable (F to F)** from the **MODEM Rx (F)** port of the ACU to the **Rx (F)** port of the modem.
2. Connect another **RF cable (F to F)** from the **MODEM Tx (F)** port of the ACU to the **Tx (F)** port of the modem.
3. Connect the **Transceiver Interface cable (DB-9 to RJ45)** from the **Transceiver I/F (DB-9)** port of the ACU to the **Transceiver I/O (RJ45)** port of the modem.
4. When using the OpenAMIP modem protocol, connect an **Ethernet cable** from the **LAN 1 (RJ45)** port of the ACU to a **LAN (RJ45)** port of the modem.



NOTE

Use the supplied Transceiver Interface Cable (D-Sub to RJ45) to connect between RS422 port of the ACU and Transceiver I/O port of the modem.

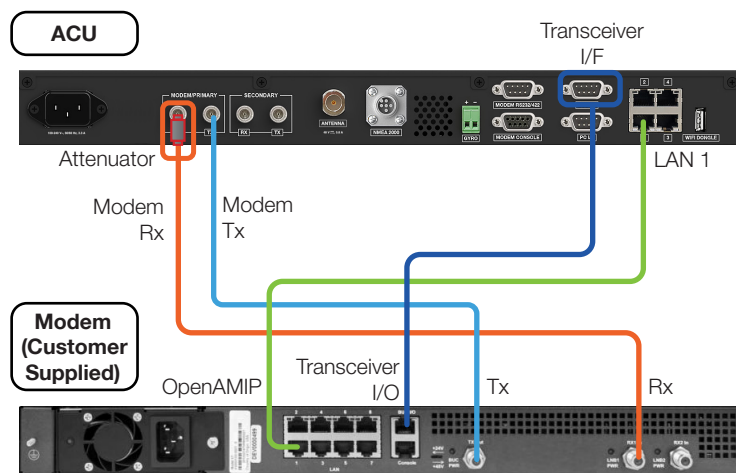

Figure 25: ACU to Modem Cable Connection

6.5.8 Connecting ACU to Switch Router

Connect an **Ethernet Cable** from the **LAN 2 (RJ45)** port of the ACU to a **LAN (RJ45)** port of the Switch Router.



Figure 26: ACU to Switch Router Cable Connection

6.5.9 Connecting ACU to Ship Gyrocompass

For satellite tracking, connect a ship gyrocompass to the antenna system through the gyrocompass interface of the ACU. The Intellian ACU supports NMEA 0183 (GYRO) gyrocompass input. If the gyrocompass has a different output standard, use a compass converter to supply the required NMEA input. The NMEA 2000 gyrocompass needs to be purchased separately. Refer to **"6.5.2 ACU Connector Pinout Guide"** on page 40 for pin configuration.

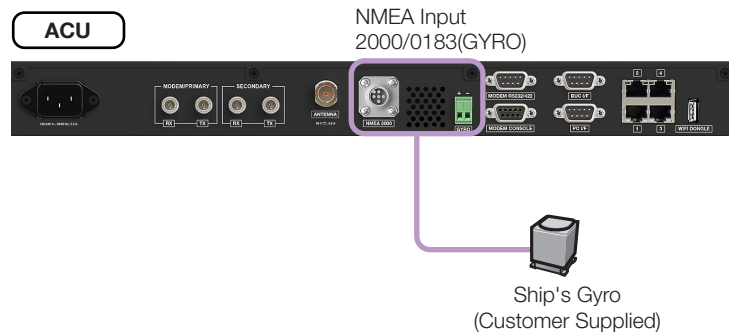
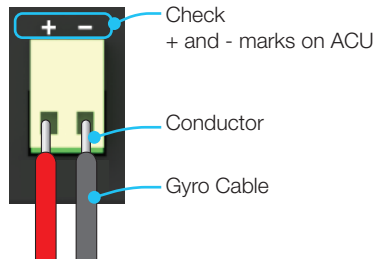

Figure 27: ACU to Ship's Gyrocompass Cable Connection

How to Connect NMEA 0183 Gyrocompass Cable

1. Using a Phillips screwdriver, loosen the two screw terminals by rotating them counterclockwise.
2. Strip wires up to 5 mm (0.2"). Do not solder the cables.
3. Insert the conductor and gyro cable wires into the – (negative) and + (positive) terminals, respectively, of the terminal block. The polarity of the terminal is indicated on the ACU with + and - marks. Check the polarity to make sure the wires are inserted correctly.



4. Fully tighten the terminal block screws by rotating them clockwise to clamp the wires securely.
5. Insert the terminal block with gyro cables to the **NMEA 0183 (GYRO) port** of ACU.

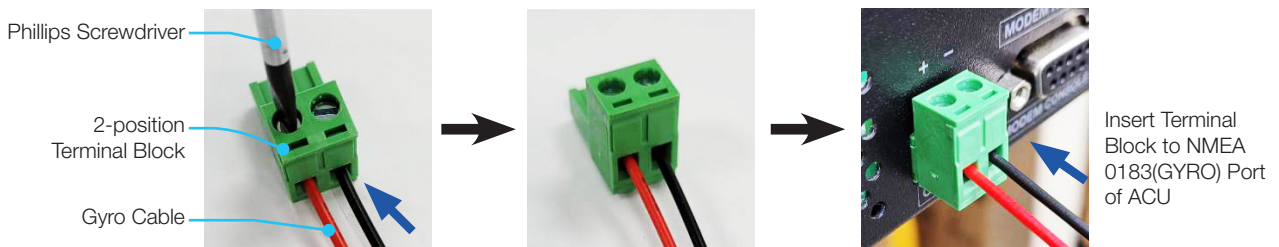

Figure 28: NMEA 0183 Gyrocompass Cable Connection

6.6 ACU to PC Communication Setup

You can establish the data communication between the ACU and a PC using a TCP/IP (Ethernet), USB, or Wi-Fi connection

6.6.1 TCP/IP Connection

Connection through Front Panel Management Port

The network is automatically configured by DHCP with no additional PC IP configuration required.

1. Connect an Ethernet cable from the management LAN port on the front panel of ACU to a LAN port of a PC. The network connection is established automatically.
2. Open a web browser (Chrome, Firefox, etc.), and then enter the following IP address to access Intellian *AptusNX* Login page.

- **IP Address: 192.168.2.1 (Default)**



Figure 29: Front Panel Management LAN Port Connection

6.6.2 USB Connection

Using Right Side USB Port on ACU Front Panel

Connect a USB flash drive to the right side USB port on the front panel of ACU to download logs, backup/restore antenna settings, and upgrade firmware.

Using Left Side USB (Serial) Port on ACU Front Panel

Connect the supplied USB Cable (A to A) from the left side USB (serial) port on the front panel of ACU to PC for monitoring and controlling the antenna system.



NOTE

- The left side USB port is only for certified engineers' use only.
- AptusNX access and iARM upgrade are NOT supported through the serial USB connection.



Figure 30: Front Panel USB Port Connection

6.6.3 Wi-Fi Connection

Connection through Wi-Fi Dongle

Intellian provides the Wi-Fi Dongle for Wi-Fi connection to AptusNX. You can connect a PC to the ACU via Wi-Fi for easy management and control whenever you are on the vessel.

1. Connect an Ethernet cable from the Management LAN port on the front panel of ACU to a LAN port of PC. The network connection is established automatically.
2. Find the Wi-Fi Dongle in the ACU box, and then insert the Wi-Fi Dongle into the USB port on the back panel of ACU.



Figure 31: Back Panel Wi-Fi Dongle Connection

3. Open a web browser, and then enter the following IP address to access Intellian AptusNX Login page.

- **IP Address: 192.168.2.1 (Default)**

4. Log in to AptusNX by typing the User Name and Password. If the system has not been changed from the factory default:

- **User Name: intellian**
- **Password: 12345678**

5. Select **SETUP** on the main menu, and then select the **Network** sub menu. Under the **Wi-Fi Access Point Configuration**, choose **Enable** for the **AP**. If you don't want to use Wi-Fi connection, choose **Disable** for the **AP**.

6. Note the **SSID** (Wi-Fi access point/network name) information.

7. Choose **Enable** for the **SSID Broadcast** option to show the **SSID** (Wi-Fi access point/network name) information.

8. Click the **Apply** button to apply the settings to the system. For more information, see **"9.8.3 iARM Save & Reboot"** on page 89.

9. After a reboot, you can connect to the Wi-Fi with any network enabled device.

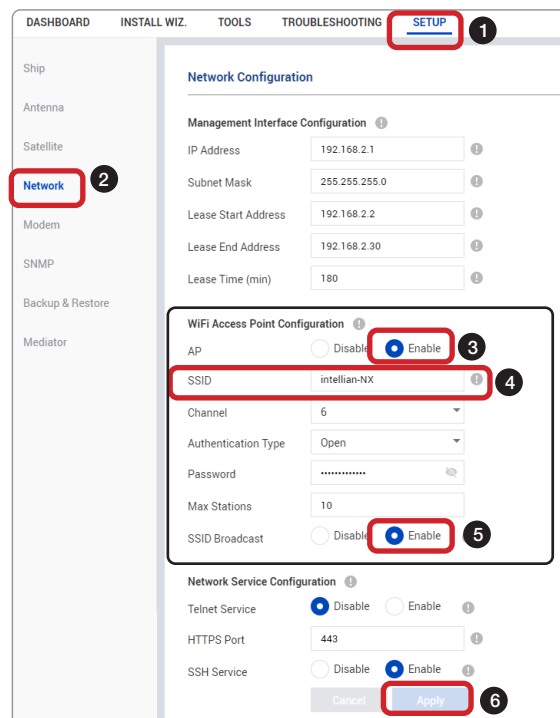

Chapter 7. Operating Install Wizard

7.1 Turning On System

Make sure the antenna has a clear view of the sky. Press the **POWER** button on the front panel of the Antenna Control Unit/ACU, and then wait a few minutes for system startup. Once the antenna finds the satellite, the **TRACKING** indicator light on the ACU display will turn green.

7.2 Accessing AptusNX

The network is automatically configured by DHCP with no additional PC IP configuration required.

1. Connect an Ethernet cable from the management LAN port on the ACU front panel to a LAN port of a PC. The network connection is established automatically.
2. Open a web browser (Chrome, Firefox, etc.), and then enter the following IP address to access Intellian **AptusNX** Login page.
 - **192.168.2.1 (Default)**
3. Log in to **AptusNX** by entering the User ID and Password.
 - **User ID: intellian (Default)**
 - **Password: 12345678 (Default)**



Figure 32: Front Panel Management LAN Port Connection

7.3 Modem Configuration

Before starting installation wizard, set up the modem configuration.

1. After accessing the **AptusNX** main page, go to **SETUP → Modem** on the main menu.

The screenshot shows the 'Modem Setting' configuration page. The top navigation bar includes 'DASHBOARD', 'INSTALL WIZ.', 'TOOLS', 'TROUBLESHOOTING', and 'SETUP' (highlighted). The left sidebar lists 'Ship', 'Antenna', 'Satellite', 'Network', 'Modem' (highlighted), 'SNMP', 'Backup & Restore', and 'Mediator'. The main content area is titled 'Modem Setting' and contains the following fields:

- Select Modem:** IDIRECT OPENAMIP
- Modem Port:** ETHERNET
- Modem Protocol:** Open AMIP
- GPS Out Sentence:** GLL
- Use Tx Mute:** YES
- Use Modem Lock:** YES

Buttons for 'Cancel' and 'Apply' are located at the bottom of the form.

2. Select your modem type from the **Select Modem** drop-down list for loading a pre-configuration of modem. The setting parameters related to the modem interface will be set automatically once the modem type is selected. If you select **USER SETTING** from the **Select Modem** drop-down list, the settings can be changed manually. Click the **Apply** button.

This screenshot is identical to the previous one, showing the 'Modem Setting' configuration page with the same fields and navigation elements.

3. Enter the modem setting values to configure the modem. Refer to the information provided by your service provider. Click the **Apply** button.

The screenshot shows the 'Modem Port Configuration' configuration page. The top navigation bar and left sidebar are the same as in the previous screenshots. The main content area is titled 'Modem Port Configuration' and contains the following fields:

- IP Address (ACU):** 10.110.5.194
- Subnet Mask:** 255.255.255.240
- Gateway:** 10.110.5.193
- DNS:** 168.126.63.1
- NAT Routing:** Enable
- TCP Modem Protocol Port:** 4001
- UDP Modem Protocol Port:** 49184

Buttons for 'Cancel' and 'Apply' are located at the bottom of the form.

4. On the pop-up window, select the checkbox if you want the system to perform the **iARM Save & Reboot** automatically. Then, click the **Confirm** button.

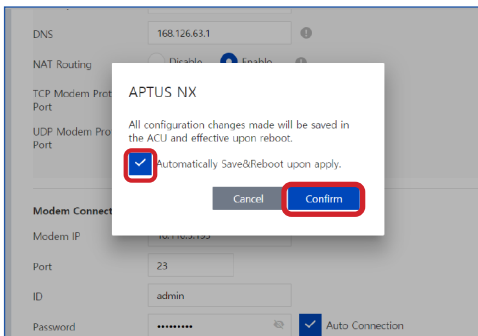

5. Reboot the system.

7.4 Starting Install Wizard

The Install Wizard will guide you through the steps of setup for the antenna system commissioning. We highly recommend using this wizard to complete the installation and commissioning of the system. You can exit the wizard at any time by clicking the **Finish** button. You can also skip steps by clicking the **Next** button. Before you start, make sure the basic devices (antenna, modem, etc.) are connected to the ACU properly. After accessing the **AptusNX** main page, go to the **INSTALL WIZ.** on the main menu then follow these steps.



NOTE

Refer to "**Chapter 9. Using AptusNX**" on page 74 for detailed description of each function.

✓ Welcome Page

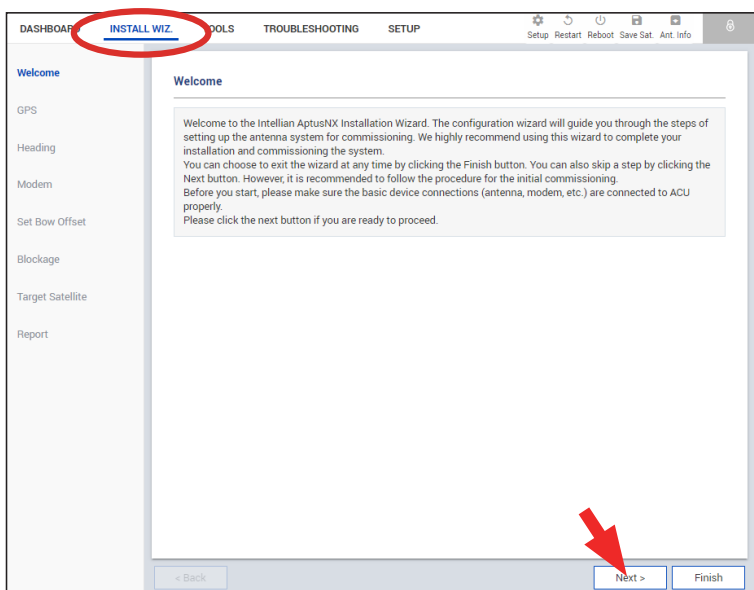

Welcome message is displayed.

Click the **Next** button.

✓ Step 1: GPS

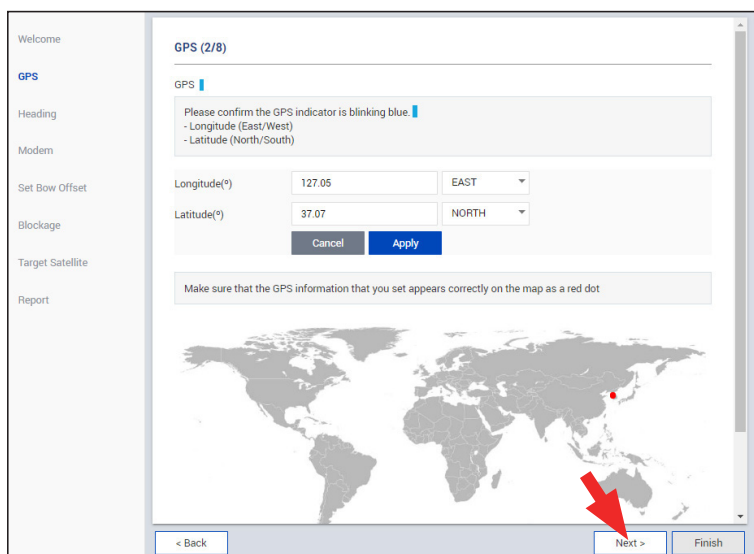

Set the GPS position of the vessel for the satellite searching. Check the GPS status connected to the antenna system. The colored indicator next to the title shows the GPS status. Make sure the GPS indicator is Blue (blinking).

- Blue (blinking): The system received a correct GPS signal.
- Red: The GPS signal is abnormal, or the received value is incorrect (Error).
- Black: The system has not received any GPS signal. You can enter the GPS value manually to set the GPS position.

Click the **Next** button to go to the next step.

✓ Step 2: Heading

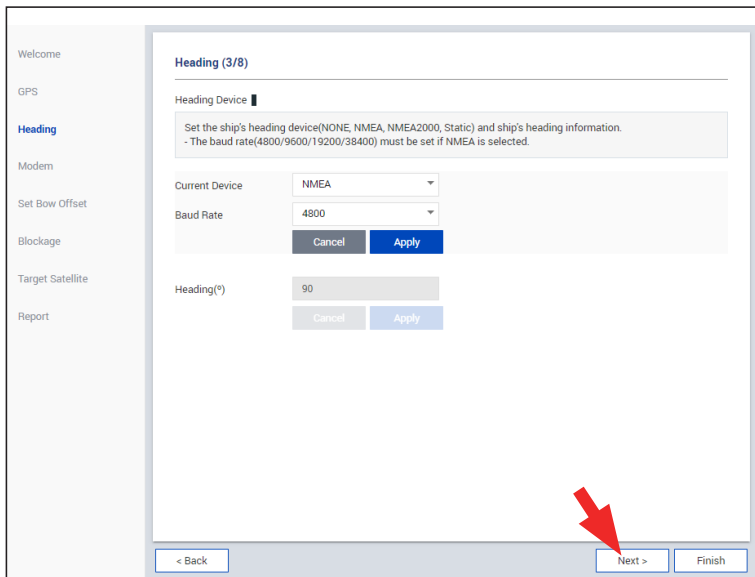

Set the ship's heading device.

The colored indicator next to the title shows the heading device connection status.

- Blue: Ship's heading device is connected.
- Black: Ship's heading device is not connected.

If a gyrocompass is connected, choose the device type from the **Current Device** drop-down list. Then, click the **Apply** button. If no gyrocompass is connected, choose **NONE** for the **Current Device** from the drop-down list. Then, click the **Apply** button.

NOTE: Skip "Step 4: Set Bow Offset" if no gyrocompass is connected.

Click the **Next** button to go to the next step.

✓ Step 3: Modem

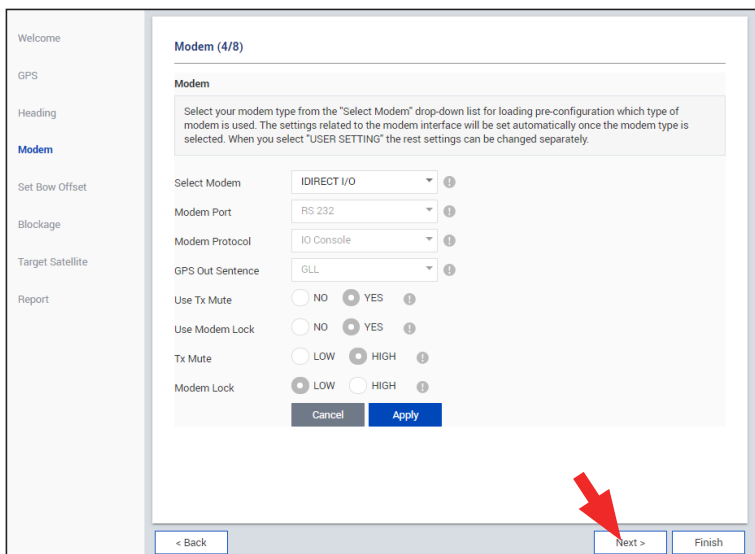

Select your modem type from the **Select Modem** drop-down list for the modem configuration. The setting parameters related to the modem interface will be set automatically once the modem type is selected. If you select **USER SETTING** from the **Select Modem** drop-down list, the settings can be changed manually.

Click the **Next** button to go to the next step.

✓ **Step 4: Set Bow Offset**

For setting BOW offset, select one of two satellite tracking types and a trackable satellite.

(Option 1: Using Beam Switch Type)

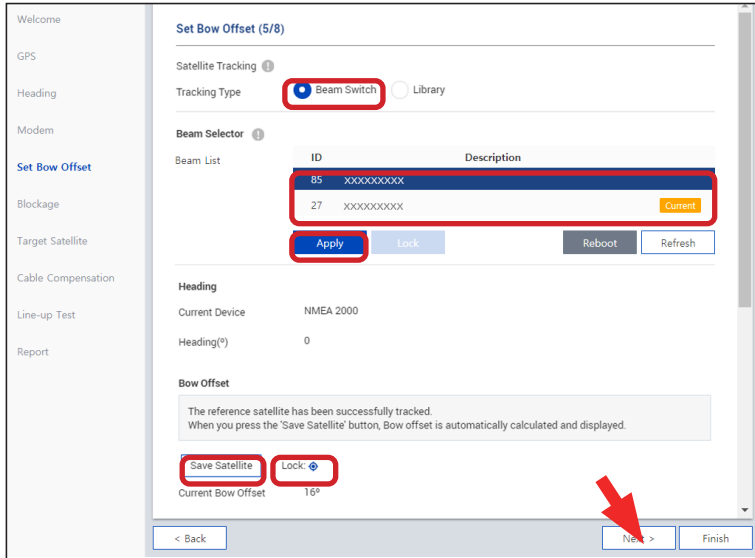

- **Step 1:** Choose the **Beam Switch** for the **Tracking Type**.
- **Step 2:** Select a satellite under the Beam List, then click the **Apply** button.

Wait while the antenna terminal tracks the satellite.

- **Step 3:** Make sure the **Lock** is on, then click the **Save Satellite** button in the **Bow Offset** menu to save the BOW offset information to ACU.

Click the **Next** button to go to the next step.

(Option 2: Using Library Type)

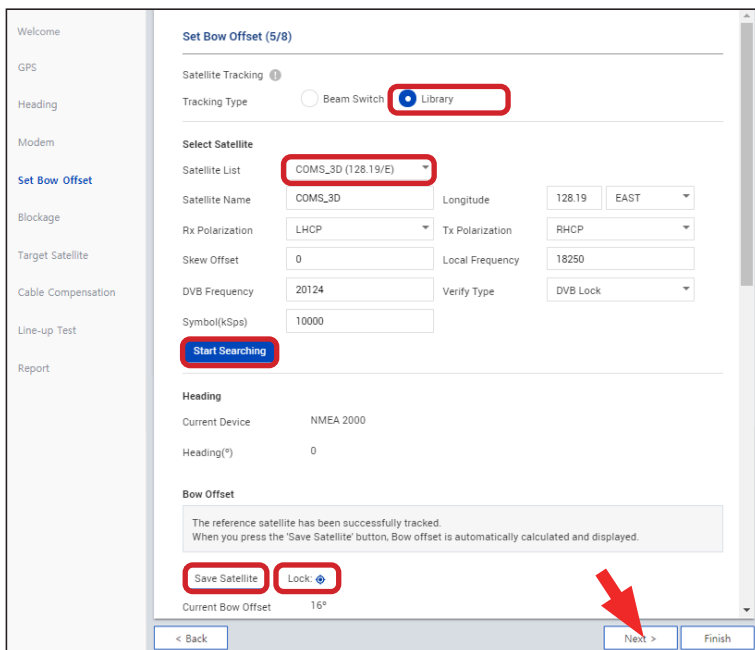

- **Step 1:** Choose the **Library** for the **Tracking Type**.
- **Step 2:** Select a satellite under the **Satellite List**, then click the **Start Searching** button.

Wait while the antenna terminal tracks the satellite.

- **Step 3:** Make sure the **Lock** is on, then click the **Save Satellite** button in the **Bow Offset** menu to save the BOW offset information to ACU.

Click the **Next** button to go to the next step.

✓ Step 5: Blockage

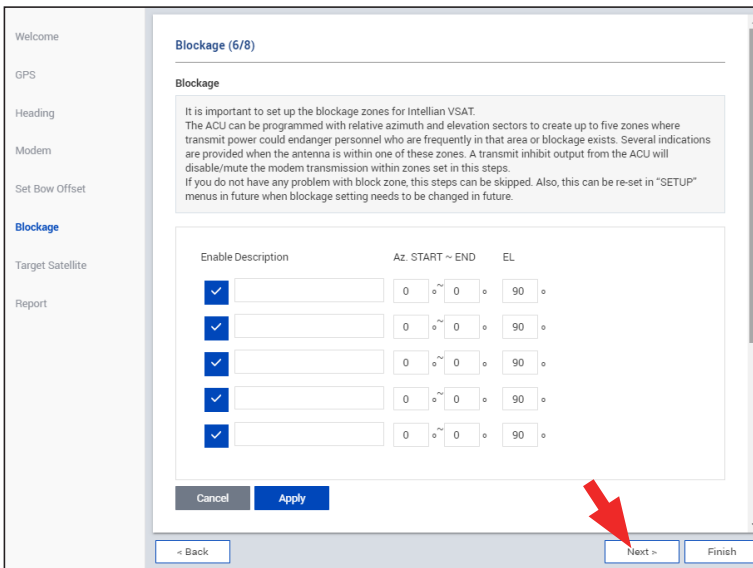

It is important to set up the blockage zones for Intellian VSAT. The VSAT system can be programmed with relative azimuth and elevation sectors to create up to five zones where transmission is muted. The **AZ START** is the relative azimuth angle where the blockage starts, and the **AZ END** is the relative azimuth angle where the blockage ends (Range: 0 ~ 360). The **EL** is the elevation angle where the blockage is set (Range: 0 ~ 90). The blockage is activated below the elevation angle.

Click the **Next** button to go to the next step.

✓ Step 6: Target Satellite

Set the target satellite to track. There are two methods for selecting a target satellite.



NOTE

The following images in this step show when the Open AMIP modem is used.

(Option 1: Using Satellite Controlled by Modem)

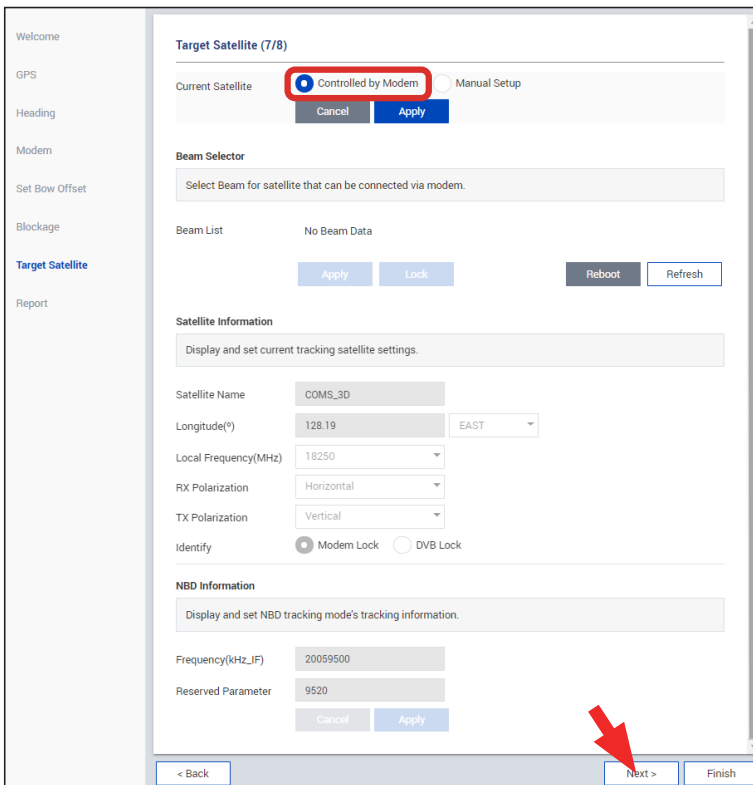

This method is generally recommended. After setting the modem connection in the **Step 3: Modem**, select the **Controlled by Modem** for the **Current Satellite**. Then, the current satellite and NBD information will be displayed automatically.

Click the **Next** button to go to the next step.

(Option 2: Using Manual Setup)

The screenshot shows the 'Target Satellite (7/8)' configuration window. At the top, there are two radio buttons: 'Controlled by Modem' (unselected) and 'Manual Setup' (selected and circled in red). Below this are 'Cancel' and 'Apply' buttons. The 'Satellite Information' section includes fields for 'Satellite Name' (SAT_000W), 'Longitude(°)' (0.7), a 'WEST' dropdown, 'Local Frequency(MHz)', 'RX Polarization' (LHCP), and 'TX Polarization' (LHCP). There are also radio buttons for 'Identify' (Modem Lock selected, DVB Lock unselected). The 'NBD Information' section has fields for 'Frequency(kHz_IF)' (20099500) and 'Reserved Parameter' (9520), with 'Cancel' and 'Apply' buttons. At the bottom, there are '< Back', 'Next >', and 'Finish' buttons. A red arrow points to the 'Next >' button.

If you did not set the modem connection, select the **Manual Setup** for the **Current Satellite**. Then enter the satellite and NBD information manually to track a satellite. Click the **Apply** button.

Click the **Next** button to go to the next step.

✓ Step 7: Report



NOTE

The following image shows when the system is using the Open AMIP modem. In case of using other modems, the displayed items on the Report may change.

The screenshot shows the 'Report (8/8)' window. At the top, there are 'Save Report', 'Export', and 'View Last Report' buttons. The 'Engineer Information' section has input fields for 'Name', 'Company', 'Certification ID', and 'Email'. The 'Line-up Test' section has a 'Test Result' header and input fields for 'Ticket Number', 'Operator', 'CPI Value(dB)' (0), and 'P1 dB Compression' (0). At the bottom, there are '< Back', 'Next >', and 'Finish' buttons. A red arrow points to the 'Finish' button.

The configuration report is displayed.

You can save the results to the ACU by clicking the **Save Report** button and download the report file (.json) by clicking the **Export** button. Click the **View Last Report** button to check the recently saved report information including the saved date and time.

After complete the steps, click the **Finish** button.

Chapter 8. Operating ACU

8.1 ACU Front Panel View

The following figure shows the features on the ACU's front panel.

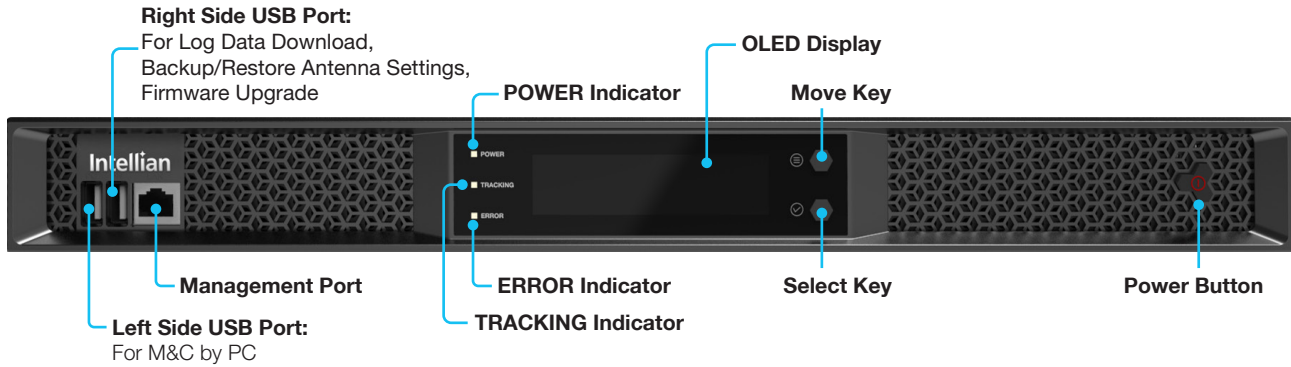

Figure 33: ACU Front Panel View

The following table describes the function of each touch key.

Touch key	Function
Power Button	Powers on/off the ACU.
Move Key	Moves to the desired screen.
Select Key	Selects the desired screen.

The following table describes status indicators on the ACU.

LED Display	Color	Description
POWER	Steady Green	The ACU is powered on.
	Off	The ACU is powered off.
ERROR	Steady Red	The antenna is in an error state.
TRACKING	Steady Green	The antenna is in tracking mode.

8.2 ACU Display Menu

The following figure shows the ACU display menu.

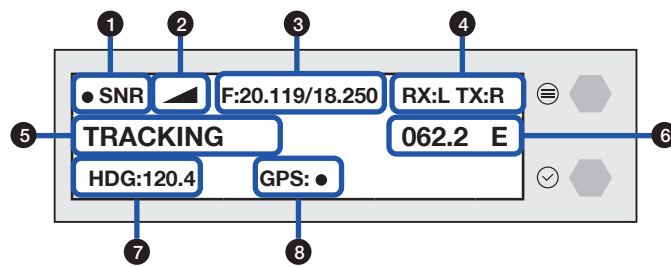

The following table shows the function of each touch key.

No.	Item	Description
①	Satellite Lock	Displays the satellite lock status.
②	Signal Level	Displays the antenna signal level.
③	Frequency Information (Target/LNB Local)	Displays the frequency information (Target / LNB Local).
④	Polarization	Displays the Rx, Tx polarization (L: LHCP, R: RHCP).
⑤	Antenna Status	Displays the antenna status (TRACKING, SEARCH 1, SEARCH 3, BEAM S/W, BLOCKING).
⑥	Target Satellite	Displays the target satellite (E: East, W: West).
⑦	Heading Information	Displays heading information (e.g. gyrocompass).
⑧	GPS Lock	Displays the GPS lock status.

8.3 Startup

After the system is installed and power is applied, the ACU display will show the following sequence.

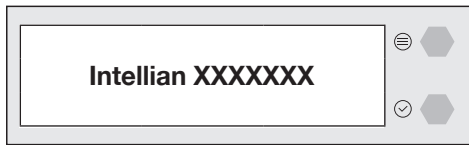

✓ **Startup**

Intellian's model name is displayed.

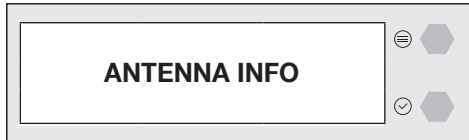

✓ **Initialize Antenna Information**

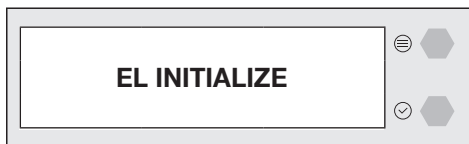

✓ **Initialize Elevation Angle**

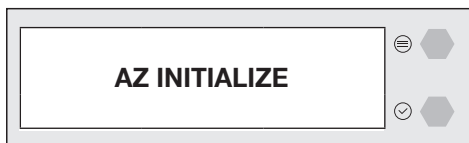

✓ **Initialize Azimuth Angle**

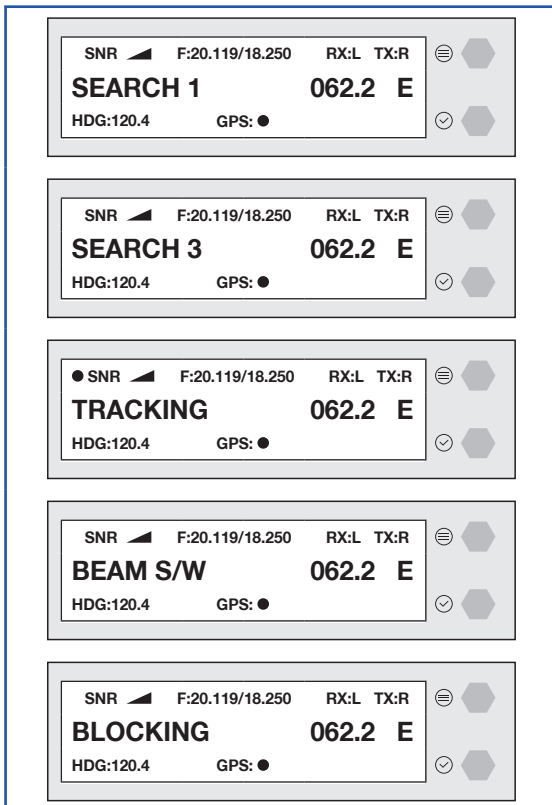

✓ **Antenna's Status**

Displays SEARCH 1 (Global Search), SEARCH 3 (Local Search), TRACKING, BEAM S/W and BLOCKING.

When the antenna is controlled by AptusNX, the ACU displays the control mode status.

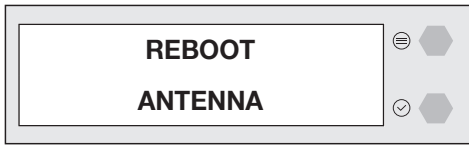

✓ **Control Mode Status**

Displays REBOOT ANTENNA mode, SETUP MODE or TEST MODE.

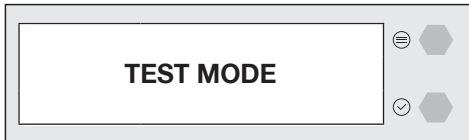
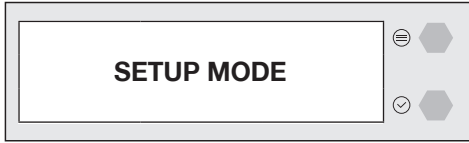

If the antenna does not communicate with ACU, the **COMMUNICATION ERROR** is displayed.

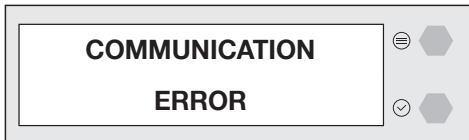

8.4 Diagnosis

Executes antenna diagnosis tests and shows the real-time diagnosis results.

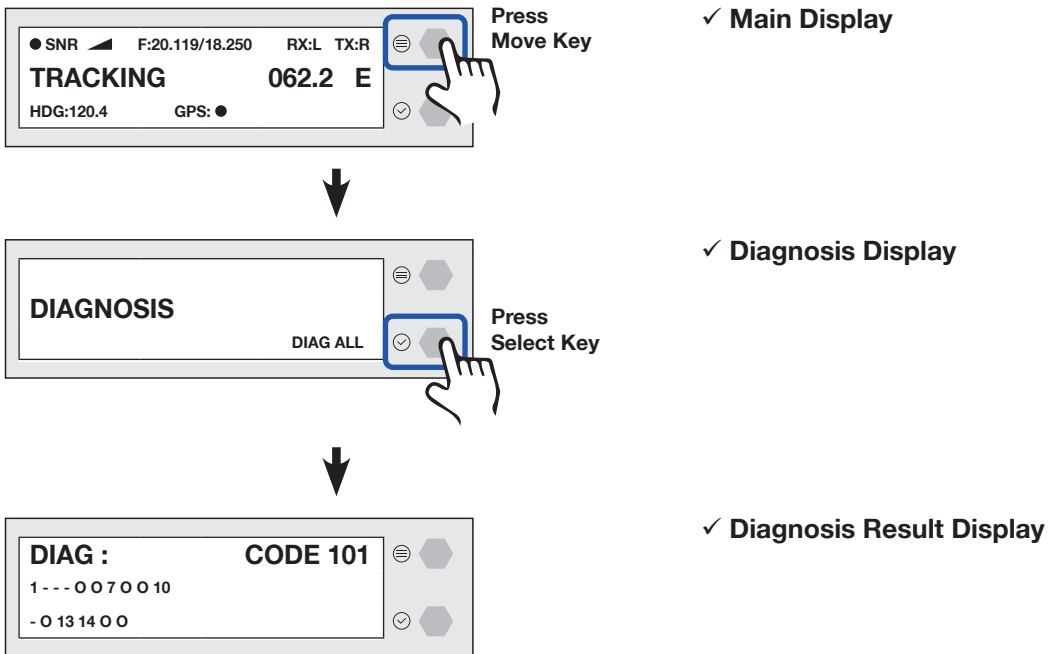

Refer to the diagnosis codes for the test results.

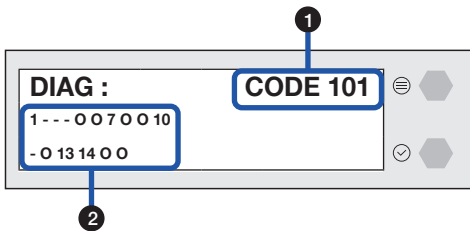

No.	Item	Description																																		
①	Diagnosis Code	<p>Displays the diagnosis code for the test that is currently running. When all tests are complete, DONE is displayed.</p> <table border="1" data-bbox="544 333 1370 1014"> <thead> <tr> <th>Code</th> <th>Test</th> </tr> </thead> <tbody> <tr> <td>101</td> <td>The data communication between the antenna and the ACU is tested.</td> </tr> <tr> <td>102</td> <td>The azimuth axis is tested.</td> </tr> <tr> <td>103</td> <td>The elevation axis is tested.</td> </tr> <tr> <td>104</td> <td>The cross-level axis is tested.</td> </tr> <tr> <td>105</td> <td>Not Available</td> </tr> <tr> <td>106</td> <td>Not Available</td> </tr> <tr> <td>107</td> <td>The rate sensor is tested.</td> </tr> <tr> <td>108</td> <td>Not Available</td> </tr> <tr> <td>109</td> <td>Not Available</td> </tr> <tr> <td>110</td> <td>The LNB / NBD is tested.</td> </tr> <tr> <td>111</td> <td>The LNB pol motor is tested.</td> </tr> <tr> <td>112</td> <td>Not Available</td> </tr> <tr> <td>113</td> <td>The antenna power is tested.</td> </tr> <tr> <td>114</td> <td>The ACU power is tested.</td> </tr> <tr> <td>115</td> <td>Not Available</td> </tr> <tr> <td>116</td> <td>The home sensor is tested.</td> </tr> </tbody> </table>	Code	Test	101	The data communication between the antenna and the ACU is tested.	102	The azimuth axis is tested.	103	The elevation axis is tested.	104	The cross-level axis is tested.	105	Not Available	106	Not Available	107	The rate sensor is tested.	108	Not Available	109	Not Available	110	The LNB / NBD is tested.	111	The LNB pol motor is tested.	112	Not Available	113	The antenna power is tested.	114	The ACU power is tested.	115	Not Available	116	The home sensor is tested.
Code	Test																																			
101	The data communication between the antenna and the ACU is tested.																																			
102	The azimuth axis is tested.																																			
103	The elevation axis is tested.																																			
104	The cross-level axis is tested.																																			
105	Not Available																																			
106	Not Available																																			
107	The rate sensor is tested.																																			
108	Not Available																																			
109	Not Available																																			
110	The LNB / NBD is tested.																																			
111	The LNB pol motor is tested.																																			
112	Not Available																																			
113	The antenna power is tested.																																			
114	The ACU power is tested.																																			
115	Not Available																																			
116	The home sensor is tested.																																			
②	Diagnosis Result	<ul style="list-style-type: none"> Below is an example of a diagnosis result: <div style="border: 1px dashed red; padding: 5px; margin: 10px 0;"> <p>1 - - - 0 0 7 0 0 10 ← Diagnosis Result of Code 101~110</p> <p>0 13 14 0 0 ← Diagnosis Result of Code 111~116</p> </div> <p>Each place in the results corresponds to the last one (codes 101 through 109) or two (codes 110 through 116) digits of a diagnosis code.</p> <ul style="list-style-type: none"> - If a dash (-) is displayed, the system passed the test. In the above example, the system passed the tests for codes 102, 103, and 104. - If the last 1 or 2 digits of a diagnosis code are displayed, the system failed the test. In the above example, the system failed the tests for codes 101, 107, 110, 113, and 114. - If O is displayed, the test was not performed. In the above example, the tests for codes 105, 106, 108, 109, 111, 112, 115 and 116 were not performed. 																																		

8.5 Antenna Information

Displays the Antenna/ACU serial number, PCU/STAB/ACU/i-ARM Version of the product.

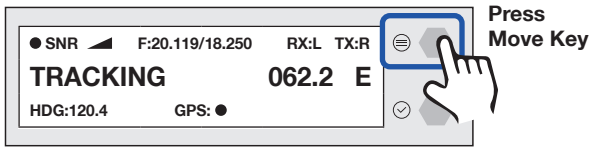

✓ **Main Display**



✓ **Diagnosis Display**



✓ **Antenna Information Display**

Product model name and antenna/ACU serial numbers are displayed.

Refer to the Antenna Information display.

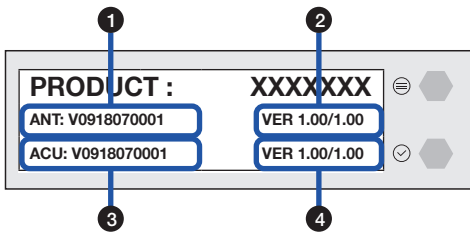

No.	Item	Description
①	Antenna Serial Number	Displays the Antenna serial number. The serial number is displayed depending on the product.
②	PCU Version/ STAB Version	Displays the PCU version / Stabilizer version.
③	ACU Serial Number	Displays the ACU serial number. The serial number is displayed depending on the product.
④	ACU Version/ i-ARM Version	Displays the ACU version / i-ARM version.

8.6 Interface Information

Displays the modem/heading type in use and the network connection status.

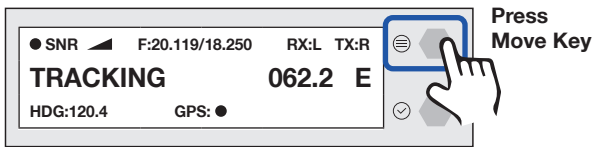

✓ **Main Display**

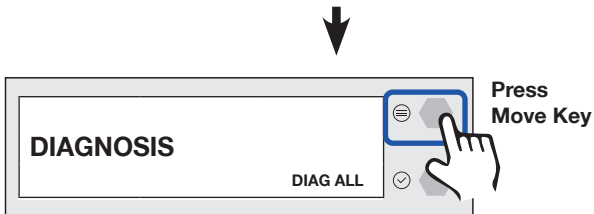

✓ **Diagnosis Display**

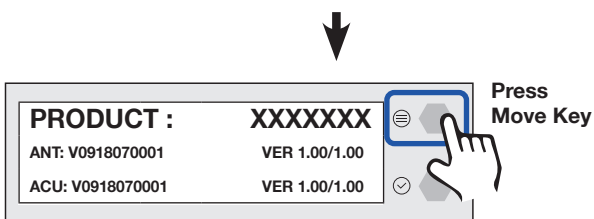

✓ **Antenna Information Display**

Product model name and antenna/ACU serial numbers are displayed.

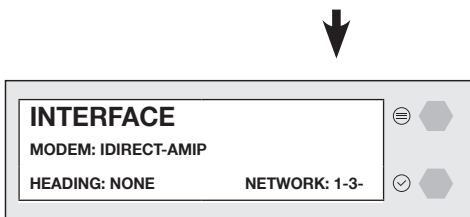

✓ **Interface Information Display**

Refer to the Interface Information.

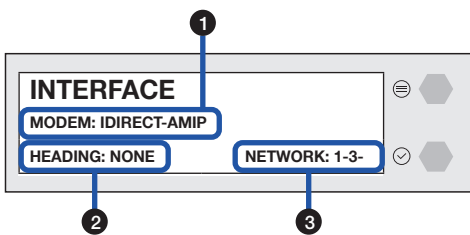

No.	Item	Description
①	MODEM	Displays the modem type in use. (IDIRECT-AMIP, SATLINK-SERIAL, IDIRECT I/O, SATLINK-VACP, NEWTEC AMIP, COMTECH I/O, ELEKTRIKOM AMIP, USER SETTING, COMTECH ROSS, GILAT-SE-II, HUGHES, IP STAR)
②	HEADING	Displays the heading type in use (NONE, NMEA0183, STATIC, NMEA2000).
③	NETWORK	Displays the network connection status with the ACU. <ul style="list-style-type: none"> An example of network result: 1-3- - ' - ' : the network is not connected. - ' 1~4 ' : the number (1~4) of connected ACU port to network.

8.7 USB Function

To use this function, insert a USB flash drive into the right side USB port on the front panel of the ACU. The USB Function includes four menus (Log Download, Firmware Upload, Backup To USB, Restore From USB). Follow the sequence below to access the USB functions. For detailed information about each function, refer to the following subsections.



NOTE

The USB function is activated only when a flash drive is detected in the front panel USB port (right side).

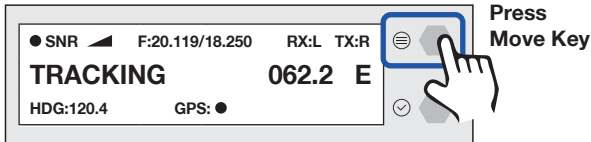

Press Move Key

✓ Main Display

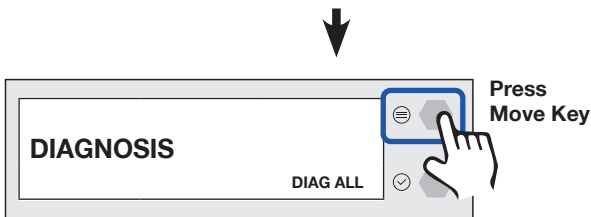

Press Move Key

✓ Diagnosis Display

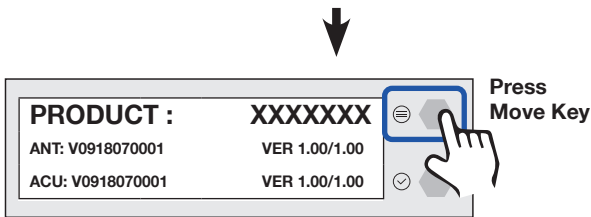

Press Move Key

✓ Interface Information Display

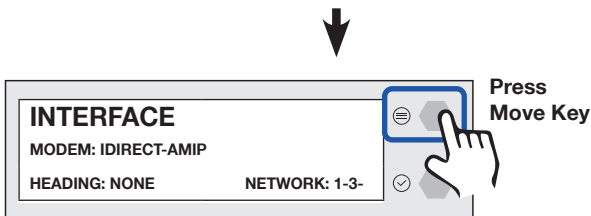

Press Move Key

✓ Antenna Information Display Product model name and antenna/ACU serial numbers are displayed.

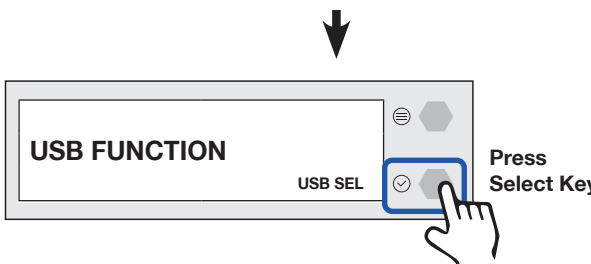

Press Select Key

✓ USB Function Display

The USB function is activated only when a flash drive is detected in the front panel USB port (right side).

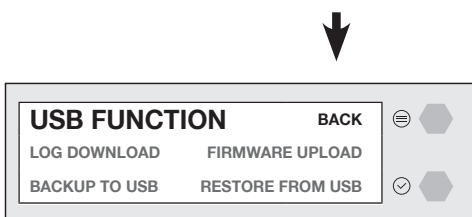

✓ USB Function Menu Display

8.7.1 Log Download

Downloads all data logs to the USB flash drive

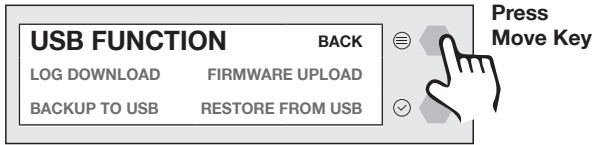

✓ USB Function Menu Display

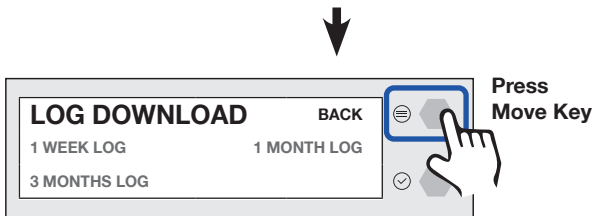
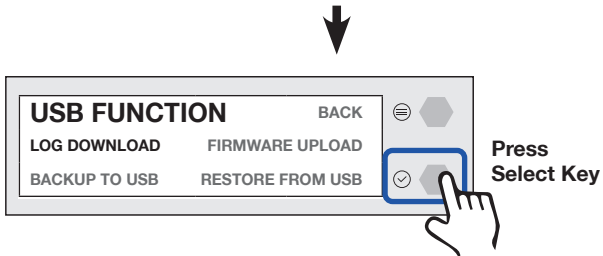

✓ Log Download Menu Display

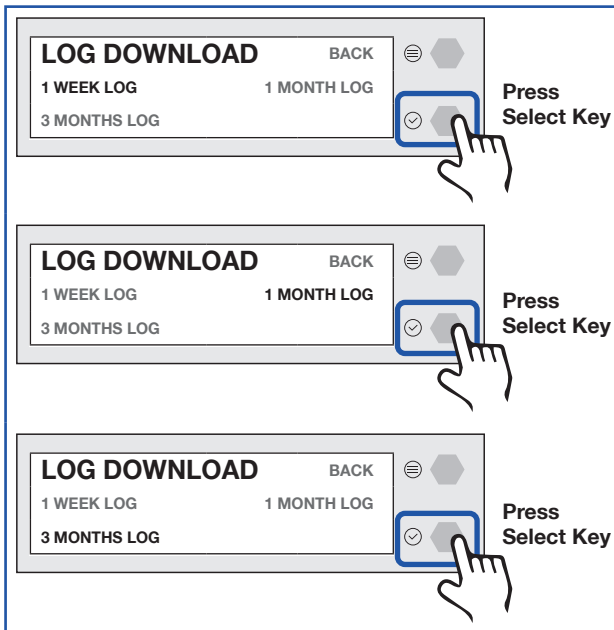

✓ Download Log File to USB

Select one of three options: 1 WEEK LOG, 1 MONTH LOG or 3 MONTHS LOG.

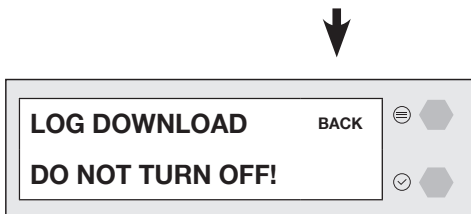

✓ Download Process Display

If there is not enough free space on the USB drive, the **NOT ENOUGH SPACE** message is displayed.

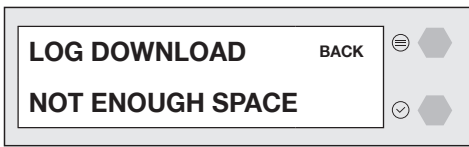

NOTE

If you want to go back to the previous screen, select the **BACK** option by pressing the **Select** key.

8.7.2 Firmware Upload

To use the Firmware Upload function, you must use the exact folder structure in the figure below. The function supports FAT32 or older formatted drives. You upgrade the antenna system by copying the FWP file to the /intellian/fw folder on a USB flash drive. You also must rename the FWP file to CTR_T4.fwp.

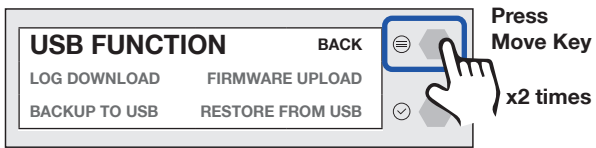
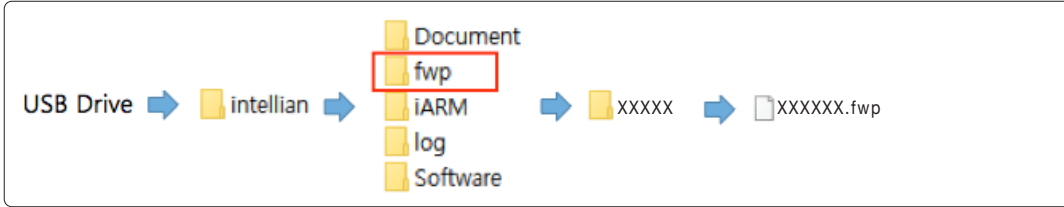

✓ USB Function Menu Display

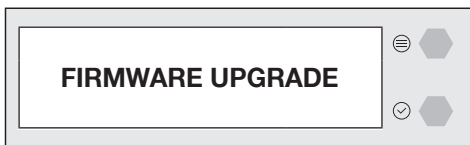
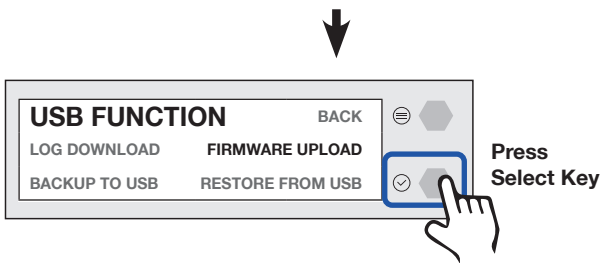

✓ Upgrade Firmware to Antenna System

If the firmware file in USB is in invalid format, the **INVALID FILE FORMAT** message is displayed.

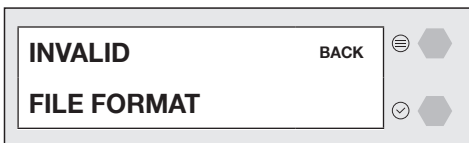

If any firmware file is not on the USB drive with the correct name and in the correct file structure, the **FILE NOT FOUND** message is displayed.

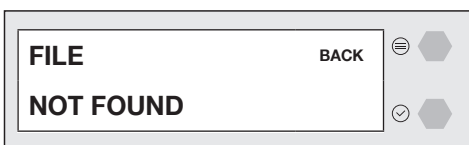

NOTE

If you want to go back to the previous screen, select the **BACK** option by pressing the **Select** key.

8.7.3 Backup to USB

Backs up the antenna setting files to the USB flash drive.

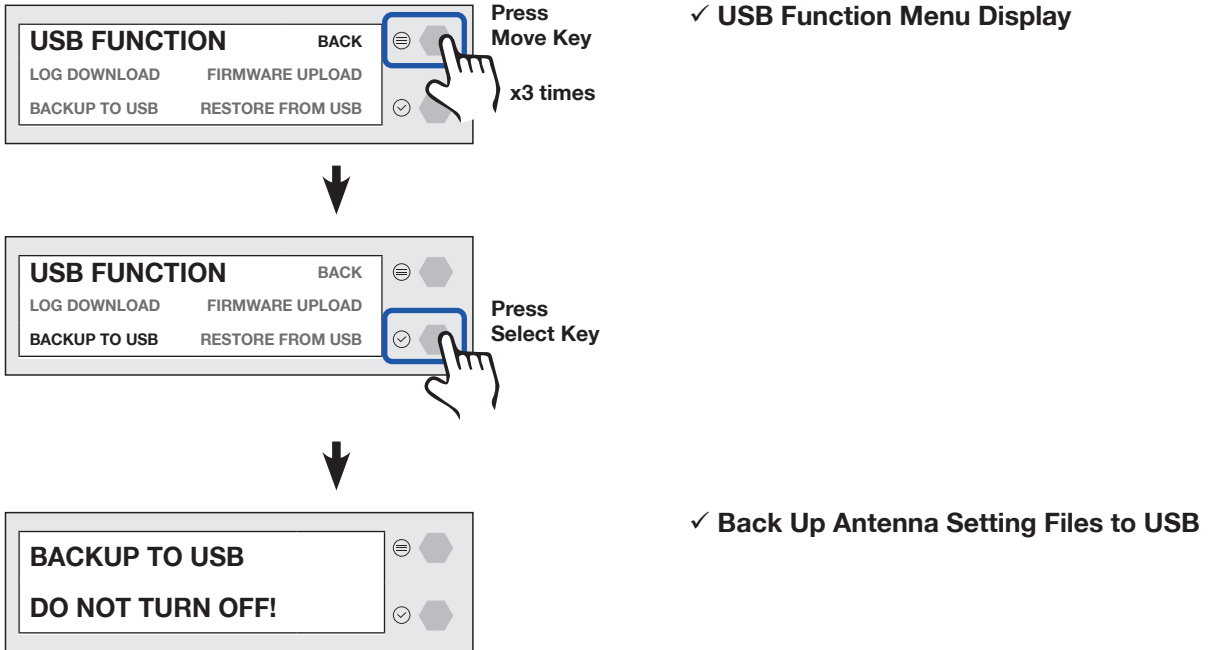

If there is not enough free space on the USB drive, the **NOT ENOUGH SPACE** message is displayed.

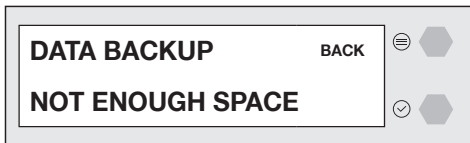

NOTE

If you want to go back to the previous screen, select the **BACK** option by pressing the **Select** key.

8.7.4 Restore From USB

Restores the antenna setting by using the setting files saved in USB flash drive.

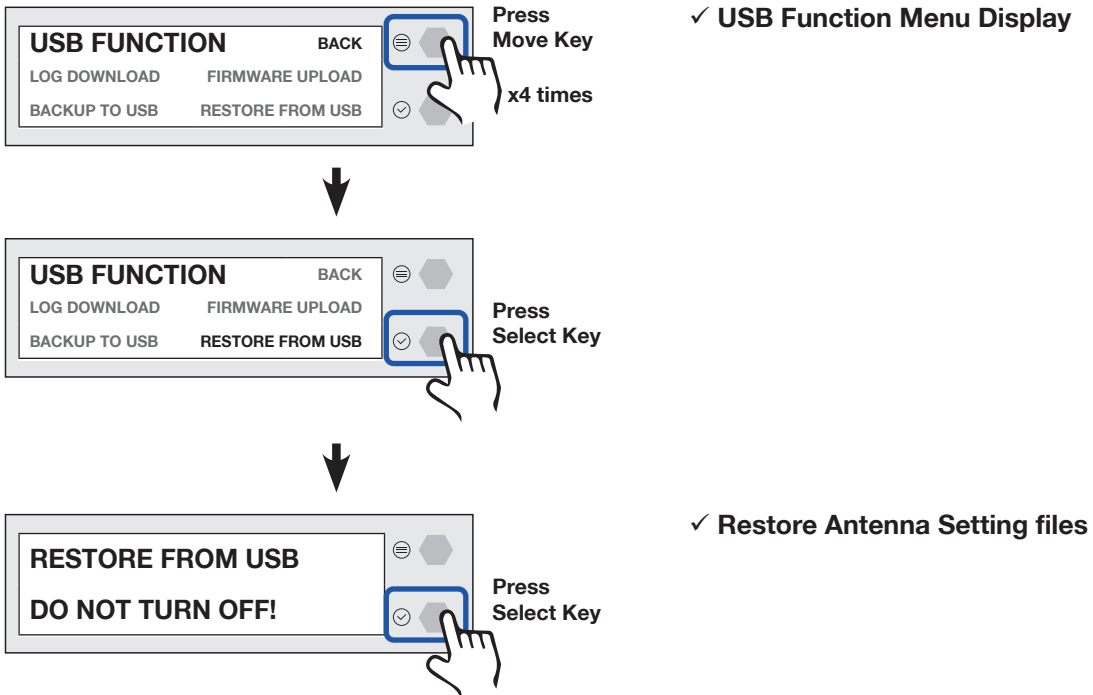

NOTE

If you want to go back to the previous screen, select the **BACK** option by pressing the **Select** key.

Chapter 9. Using AptusNX

9.1 Introduction

With the embedded **AptusNX** software, the antenna can be monitored, controlled, and diagnosed remotely from anywhere, anytime through TCP/IP protocol. This saves you the time and cost generated by various maintenance activities, such as upgrading firmware, tracking parameter resets, and diagnosing system issues.

9.2 Accessing AptusNX for ACU

1. Connect an Ethernet cable from the management LAN port on the front panel of the ACU to a LAN port of PC. This method is generally recommended.
2. Enter the ACU IP address (**Default: 192.168.2.1**) into the address bar of your web browser. The AptusNX Login page displays.



NOTE

AptusNX works on Internet Explorer 11 or higher (Windows 7 or higher editions), Firefox, Microsoft Edge and Chrome web browsers.

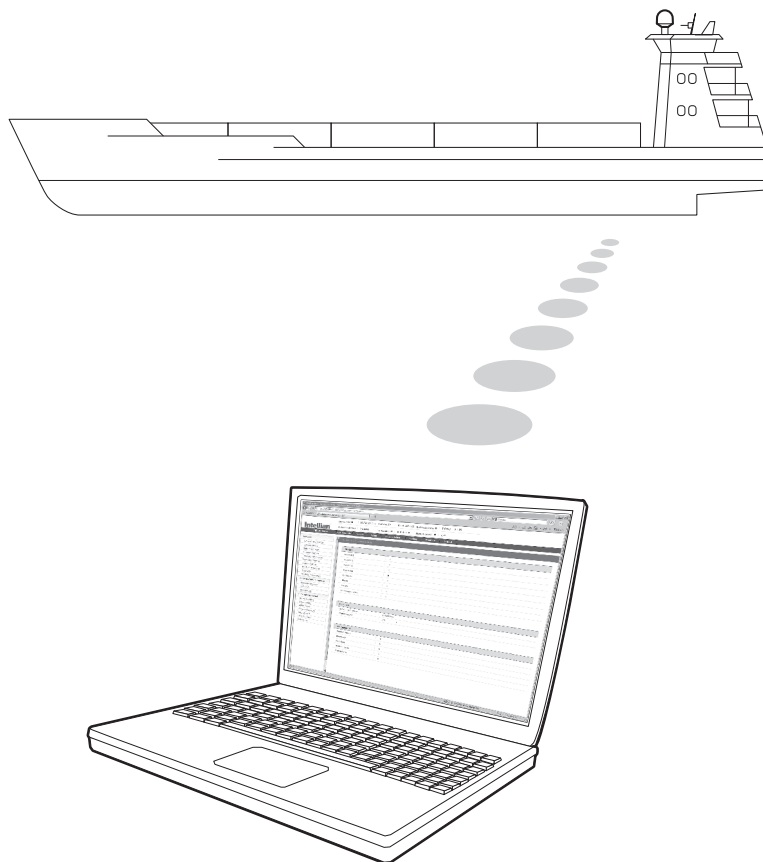

9.3 Main Page (Page Login)

The Intellian software Aptus provides different user access levels to protect the system for safe operation. Depending on the user level, the accessible functions in the software may be limited (see the table below).

Log into the ACU by typing in a User ID and Password. The table below contains the factory default values.

User Type	User ID	Password	Access Authority
Admin	<i>intellian</i>	<i>12345678</i>	All menus for monitoring and setting
	<i>captain</i>	<i>12345678</i>	All menus for monitoring and setting Assigns permissions to users
User	<i>guest</i>	<i>guest</i>	Limited menus for monitoring (Dashboard, Tools, Troubleshooting)

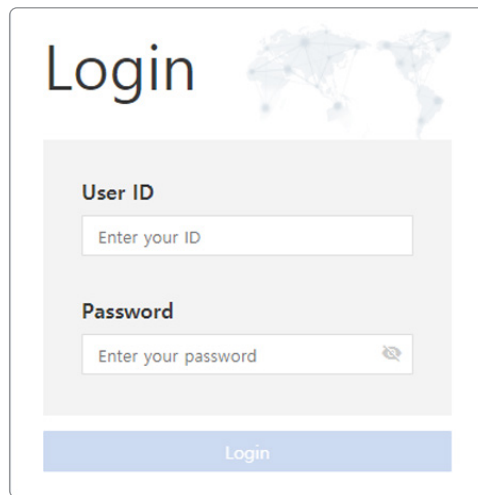



NOTE

After entering with the default password, the user must change the default password to a new password for security.

9.4 Top Menus

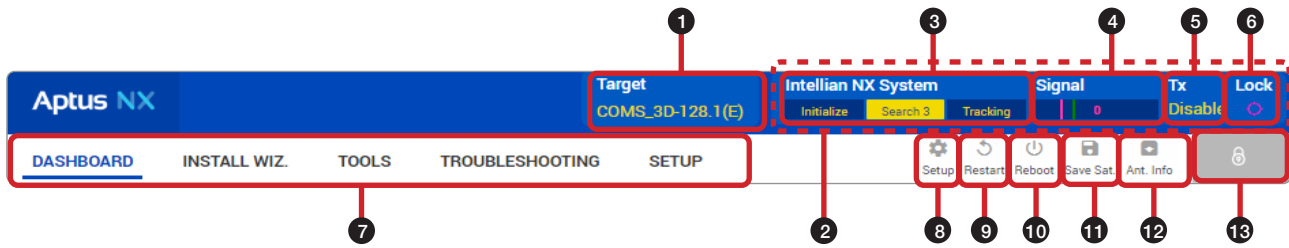
Once you log in, the following information and menus are displayed.



No.	Item	Description												
①	Target Satellite	Displays the name of the targeted satellite.												
②	Quick Status Screen Area	When clicking this top menu area (marked in the red dotted box), the "Quick Status Screen" appears. You can quickly monitor each status of the five items (Enable Mode, Blockage, Pointing, Modem Lock) through the screen (Blue: enable, Black: disable). <div style="border: 1px solid black; padding: 5px; margin-top: 10px;"> <p>APTUS NX</p> <ul style="list-style-type: none"> ■ Enable Mode ■ Blockage ■ Pointing ■ Modem Lock <p style="text-align: right;">Close</p> </div> <p style="text-align: right; margin-top: 5px;"><Quick Status Screen></p>												
③	Antenna Status Info	Displays the antenna status/mode. <ul style="list-style-type: none"> Initialize: The antenna system is initializing. Searching: The antenna is searching for the target satellite. Tracking: The antenna is tracking the target satellite. 												
④	Signal Level	Displays the current signal level using a yellow bar indicator. The length of the bar increases with signal strength.												
⑤	Tx Status	Displays whether the antenna is able to transmit data or not.												
⑥	Lock	Displays the satellite lock status. If the lock icon is lit green, the antenna has locked on the satellite.												
⑦	Main Menu	Select a main menu item (DASHBOARD, INSTALL WIZ., TOOLS, TROUBLESHOOTING, SETUP). Each main menu item displays sub menus on the left of the screen.												
⑧	Setup	Enter the setup mode to modify settings. The following functions are available only in setup mode. <table border="1" style="width: 100%; border-collapse: collapse; margin-top: 10px;"> <thead> <tr> <th>Main Menu</th> <th>Side Menu</th> <th>Function</th> </tr> </thead> <tbody> <tr> <td rowspan="4">SETUP</td> <td rowspan="3">Antenna</td> <td>Antenna Angle</td> </tr> <tr> <td>Dish Scan Range Check</td> </tr> <tr> <td>Sensor Calibration <ul style="list-style-type: none"> Tilt Sensor Bias Rate Sensor Bias </td> </tr> <tr> <td>Antenna Mode <ul style="list-style-type: none"> Set Idle Mode </td> </tr> <tr> <td></td> <td>Backup & Restore Setting</td> <td>Antenna Restore</td> </tr> </tbody> </table>	Main Menu	Side Menu	Function	SETUP	Antenna	Antenna Angle	Dish Scan Range Check	Sensor Calibration <ul style="list-style-type: none"> Tilt Sensor Bias Rate Sensor Bias 	Antenna Mode <ul style="list-style-type: none"> Set Idle Mode 		Backup & Restore Setting	Antenna Restore
Main Menu	Side Menu	Function												
SETUP	Antenna	Antenna Angle												
		Dish Scan Range Check												
		Sensor Calibration <ul style="list-style-type: none"> Tilt Sensor Bias Rate Sensor Bias 												
	Antenna Mode <ul style="list-style-type: none"> Set Idle Mode 													
	Backup & Restore Setting	Antenna Restore												
⑨	Restart	Exits the Setup mode and switches to the normal mode (Searching/Tracking mode).												
⑩	Reboot	Powers off and restarts the antenna system. After system initialization, the antenna switches to normal mode (Searching/Tracking mode).												
⑪	Save Sat.	Saves current satellite settings. Bow offset will be adjusted and saved automatically.												
⑫	Ant. Info	Obtains current antenna information.												

No.	Item	Description
⑬	Account Button	Click the  button to manage the user account. The Account , System , and User Mgr. menus are for user management. Click the Logout button to log out of the <i>AptusNX</i> web page.

9.5 Account Menu

1. Click the  button to manage the user account.
2. Select **Account**, **System**, or **User Mgr.** for user management. Select **Logout** to log out of *AptusNX*.

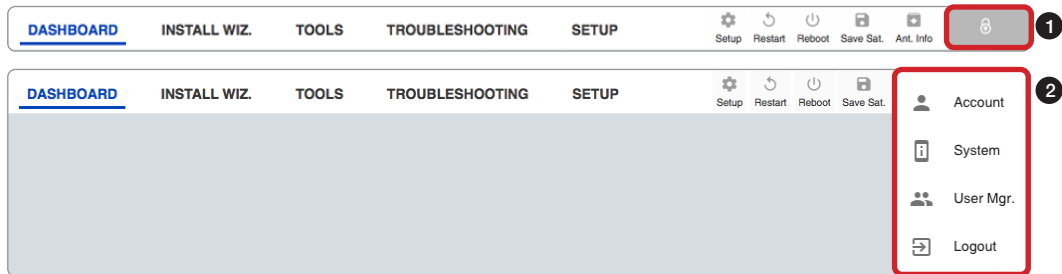

9.5.1 Account

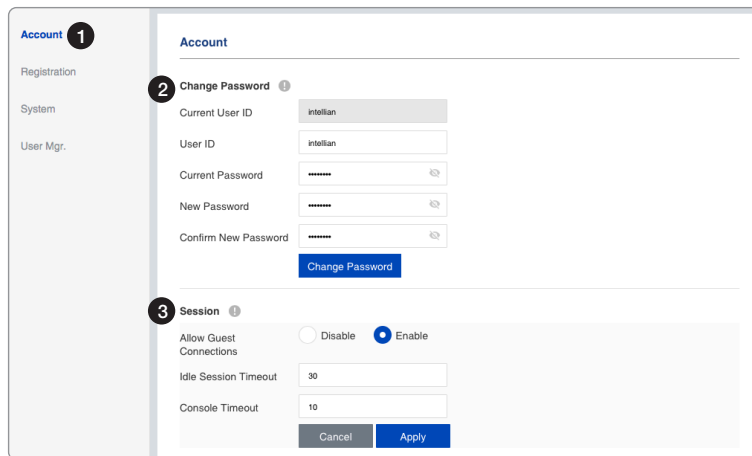

No.	Item	Description
①	Account	Updates your password and sets timeouts.
②	Change Password	<p>You can change your password.</p> <ul style="list-style-type: none"> • Current User ID: Displays your user ID. • User ID: Enter the current user ID. • Current Password: Enter the current password. • New Password: Enter the new password. • Confirm New Password: Re-enter the new password to verify that it was entered correctly. <p>Click the Change Password button to set the password to the new password. For the next login, the new password is required.</p>
③	Session	<p>You can give guests the accessibility to the AptusNX and set time-outs.</p> <ul style="list-style-type: none"> • Allow Guest Connections: Select the guest's accessibility to the system (Disable / Enable). • Idle Session Timeout: Set the idle session timeout. • Console Timeout: Set the console timeout. <p>Click the Apply button to apply the settings to the system.</p>

9.5.2 Registration

The screenshot shows a web interface for product registration. On the left is a navigation menu with 'Registration' selected. The main content area is titled 'Registration' and includes a message: 'For better customer service, please register your product information and customer information. Thank you.' Below this are four numbered sections: 'Product' with 'Antenna' and 'Serial Number' fields; 'Vessel' with 'Has IMO Number' radio buttons (Yes/No), 'Ship Name', 'Type', and 'Owner' text boxes; and 'Service Provider' with three text boxes. At the bottom are 'Cancel' and 'Register(Update)' buttons.

No.	Item	Description
①	Registration	Enter the product registration information for your convenience. Click the Register (Update) button to apply the settings to the system.
②	Product	Displays the antenna information. <ul style="list-style-type: none"> • Antenna: Displays the antenna name. • Serial Number: Displays the antenna serial number.
③	Vessel	Enter the vessel information. <ul style="list-style-type: none"> • Has IMO Number: Choose whether you have the IMO number or not. If you have the IMO number, select Yes and enter the number. If you do not have the IMO number, select No and enter the Ship Name, Type, and Owner information. • IMO Number: Enter the IMO number. • Ship Name: Enter the ship name. • Type: Enter the ship type. • Owner: Enter the owner's name.
④	Service Provider	Enter the information of your service provider. <ul style="list-style-type: none"> • Service Provider 1/2/3: Enter the names of service providers.

9.5.3 System

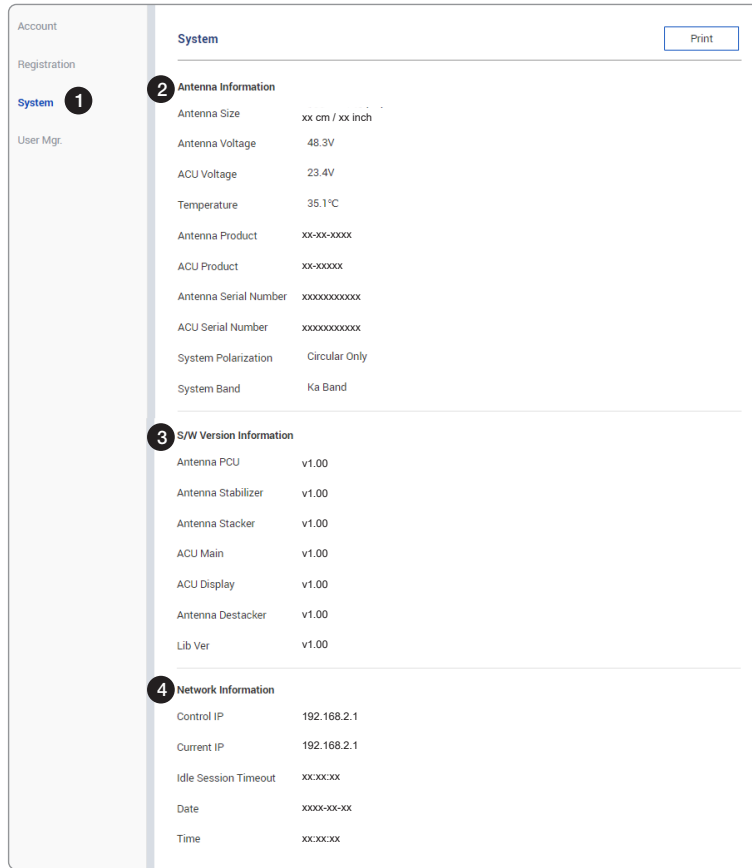

No.	Item	Description
①	System	Use this page to display system information and change the antenna name.
②	Antenna Information	Displays antenna information.
③	S/W Version Information	Displays S/W version information.
④	Network Information	Displays network information.

9.5.4 User Manager

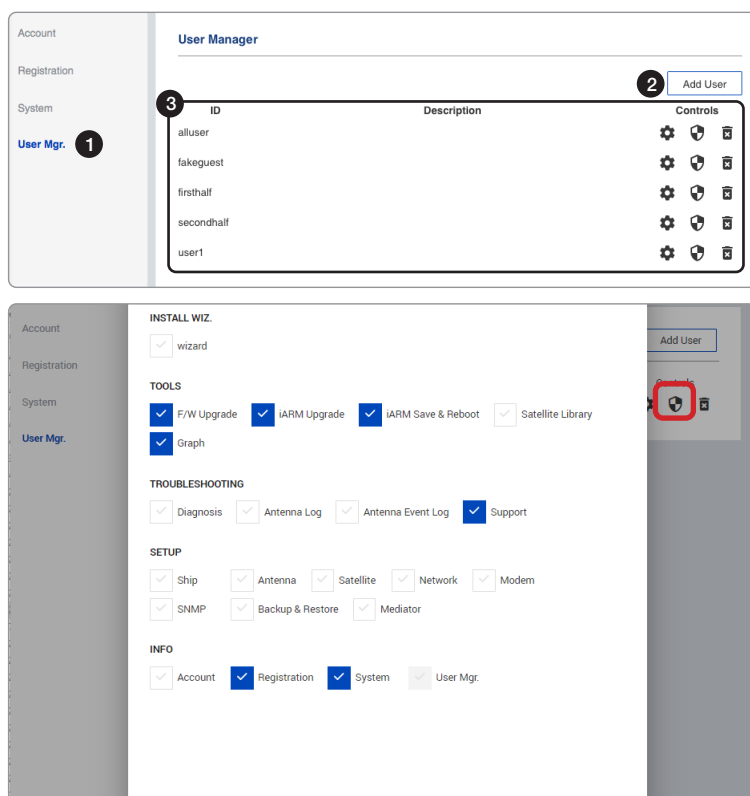

Editable User Permissions Menu

No.	Item	Description
①	User Manager	The captain with admin permissions can control and manage user permissions separately.
②	Add User	Creates new user accounts. To create a new user account, do the following: <ol style="list-style-type: none"> 1. Click the Add User button. The User Manager window is displayed. 2. Enter the new user ID, Password, and Description (optional). 3. Under Menu Authorization, select the pages to which you want the user to have access. 4. Click the Add User button.
③	User Management List	Displays the user management state and can control and manage through the control buttons. <ul style="list-style-type: none"> • ID: Displays the registered user ID. • Description: Displays the user's description. • Controls: Click the control, and then select one of the following commands to manage the selected user account. <ul style="list-style-type: none"> - User Setting: Reset the user ID by clicking the Update User button, and changes the password by clicking the Reset Password button. - Edit Menu Permission: Choose user permissions to give by selecting the checkboxes, then click the Apply button. The user can access only the permitted options. - Delete User: Deletes the user.

9.6 Dashboard

The Dashboard menu item provides access to quick monitoring of the antenna status. Once displayed, the Dashboard helps you arrange panels on a single screen, while providing you with a broad view of a variety of information at once. You can customize the dashboard by rearranging the panels to make them more readable and user-friendly.

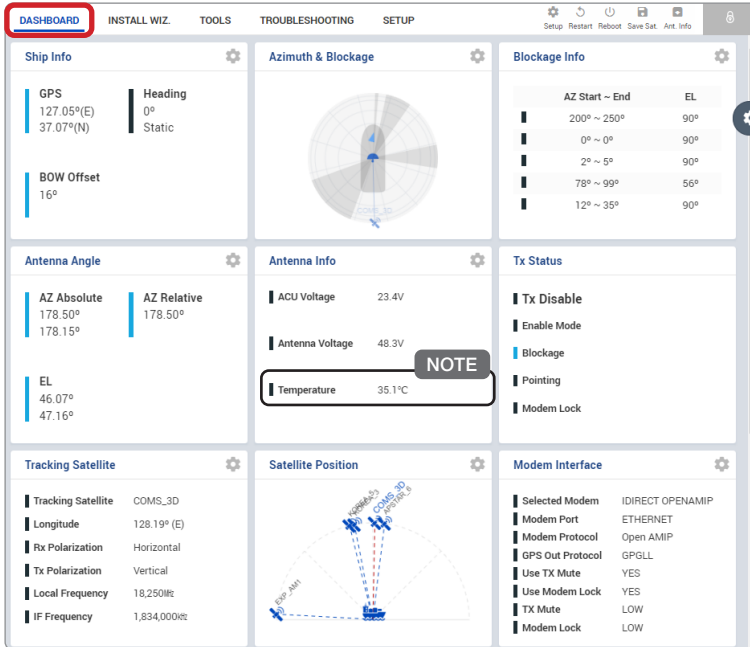

NOTE

In the BUC Info panel, the measured temperature can be different from the actual temperature.

9.6.1 How to Add & Remove Panels (Dashboard Setting)

Adding Panels

1. Click the gear icon on the right side of the page (see figure below). The Dashboard Setting window displays.
2. Check the box of the panel that you wish to add to the dashboard.
3. Click the **Apply** button to apply the settings to the system. Once the panel is added, it will be automatically placed at the bottom of the page.

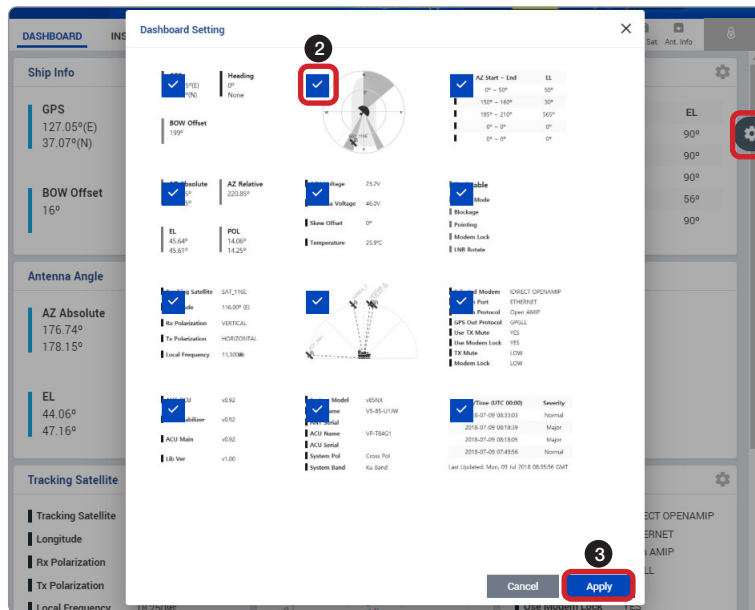

Removing Panels

1. Click the gear icon on the right side of the page (see figure below). The Dashboard Setting window displays.
2. Uncheck the box of the panel that you wish to remove from the dashboard.
3. Click the **Apply** button to apply the settings to the system.

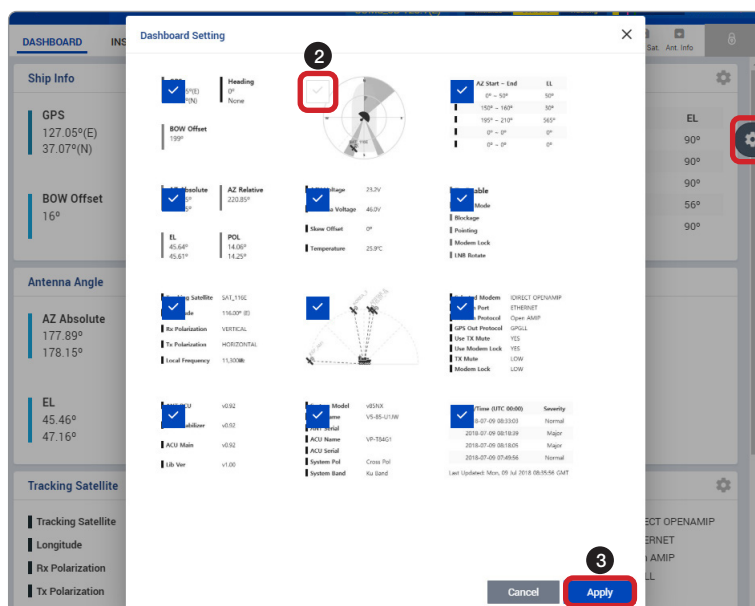

9.6.2 How to Arrange Dashboard Layout

You can customize the dashboard by rearranging panels as you wish.

1. Click and hold the left mouse button on a panel's title and then drag-and-drop in the desired position.

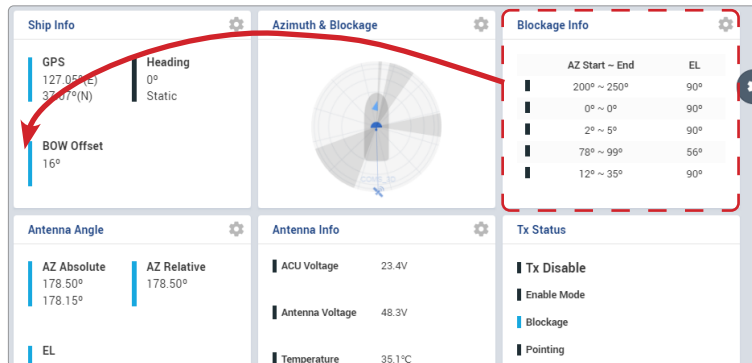

2. This time, the selected panel will be moved to the desired position. You can also move multiple panels into a customized layout in the same manner.

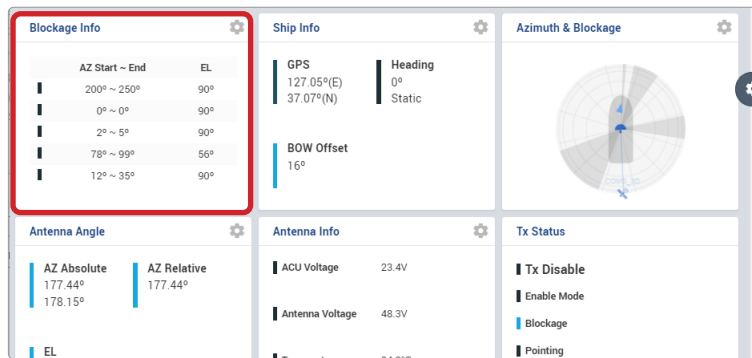

9.6.3 How to Use Shortcut Settings

Many panels on the dashboard provide shortcut function. Using the **Shortcut** button on right side of the panel, you can easily access detailed information and manage settings.

1. Click the **Shortcut** button(⚙️) to open the setting page.

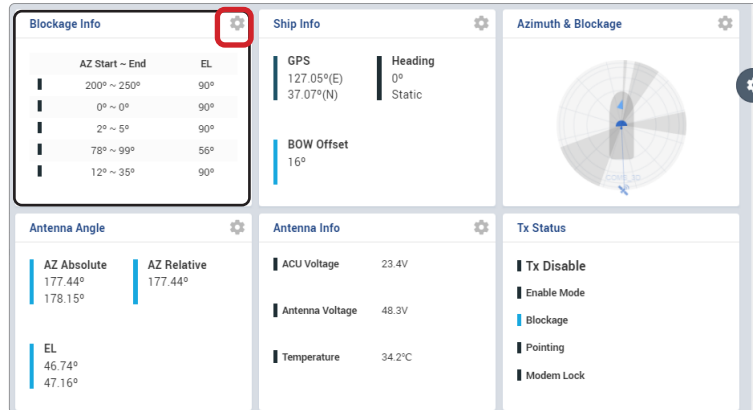

The setting page will appear on an individualized web page. On settings pages, you can check the detailed information and quickly apply the settings that you wish.

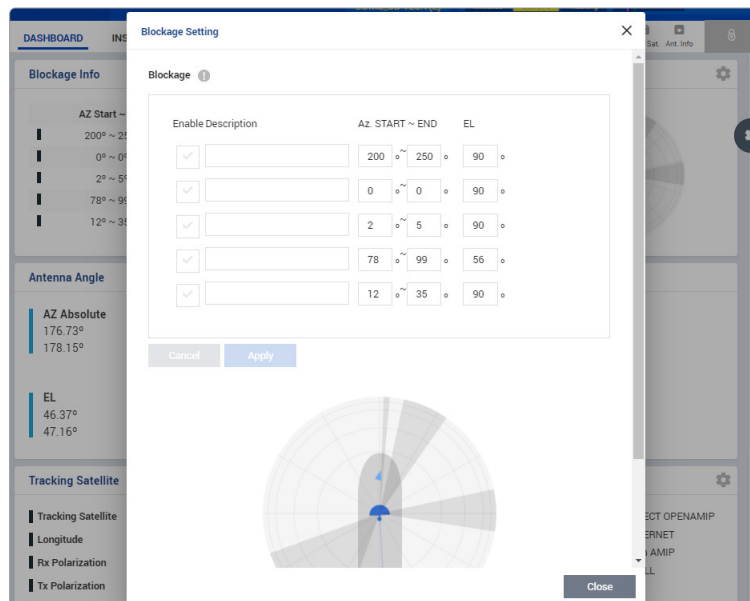

9.7 Install Wizard

The description of this menu is written on the previous page. Refer to the "7.4 Starting Install Wizard" on page 55 for more details.

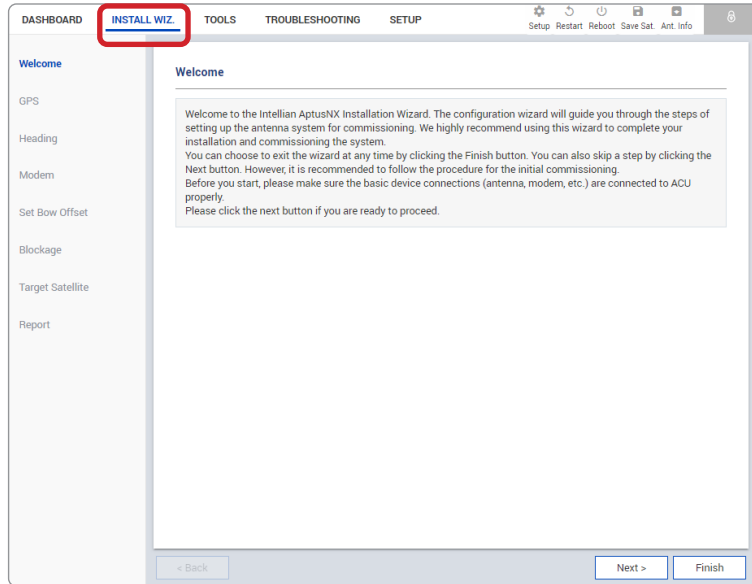

9.8 System Tools

This menu sets and displays the F/W Upgrade, iARM Upgrade, iARM Save&Reboot, Satellite Library, and Graph function.

9.8.1 Firmware Upgrade

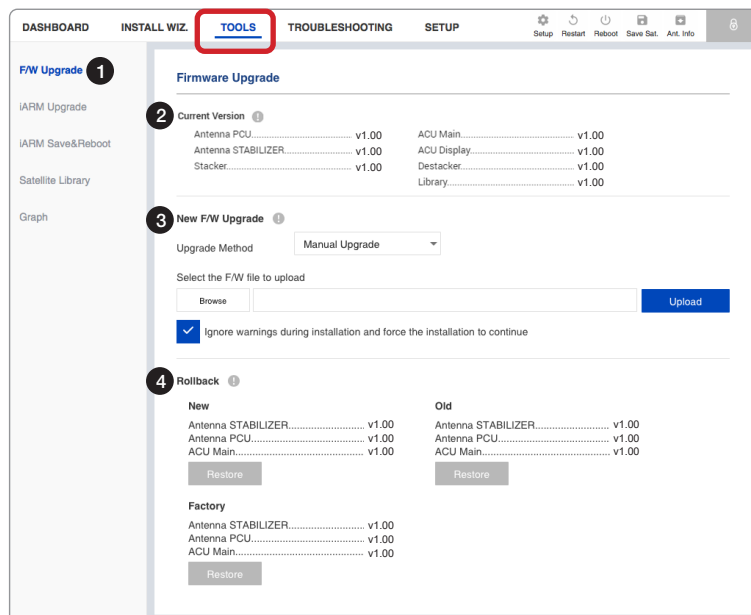

No.	Item	Description
①	Firmware Upgrade	Displays current firmware versions and upgrades antenna firmware.
②	Current Version	Displays current firmware versions (Antenna STABILIZER, Antenna PCU, ACU Main, Library, Stacker, Destacker, ACU Display)
③	New F/W Upgrade	<p>Upgrades antenna firmware. The update may take a few minutes to complete. The upload time may vary due to a variety of factors such as the speeds of your network. Uploading an incorrect firmware file may cause serious damage to your antenna and ACU. Check firmware version before uploading firmware.</p> <ul style="list-style-type: none"> Upgrade Method: Selects an upgrade method between Manual Upgrade or Auto Upgrade. <p>NOTE: For the Manual Upgrade method, refer to the following "Antenna Firmware Upgrade (Manual Upgrade) Procedures" for more details.</p>
④	Rollback	<p>Displays the new, previous/latest, and factory default firmware package versions and allows you to rollback to them.</p> <ul style="list-style-type: none"> New: Most currently upgraded version of firmware Old: Previous version of firmware before the upgrade Factory: Initial version of firmware which was installed by the factory <p>The new, old or factory version of firmware can be restored by clicking on the RESTORE button.</p>

Antenna Firmware Upgrade (Manual Upgrade method) Procedure

1. Choose **Manual Upgrade** from the pull-down menu of **Upgrade Method**. **Browse** and , in the Windows Open dialog box, select the upgrade package file to upload.
2. Click the **Upload** button to transfer the firmware package file (*.fwp-in.) to iARM module. The antenna firmware versions are displayed on the pop-up window.



NOTE

If you select the box "Ignore warnings during installation and force the installation to continue", warning messages do not appear during the upgrade.

3. Check the current version installed and the new version available, and then click the **Start Upgrade** button.

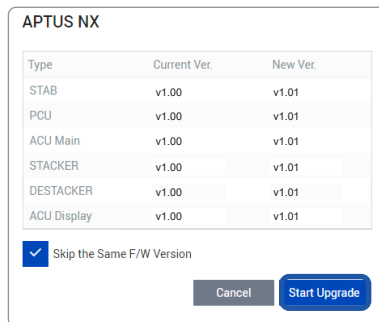

The upgrade process is displayed on the window.

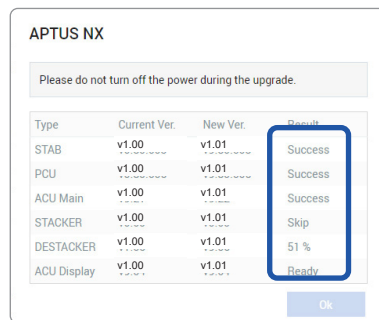

If the firmware is successfully upgraded, "Success" will be displayed in the Status column.

4. Click the **OK** button to close the pop-up window.

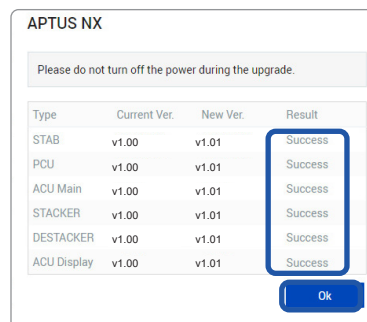

9.8.2 iARM Upgrade

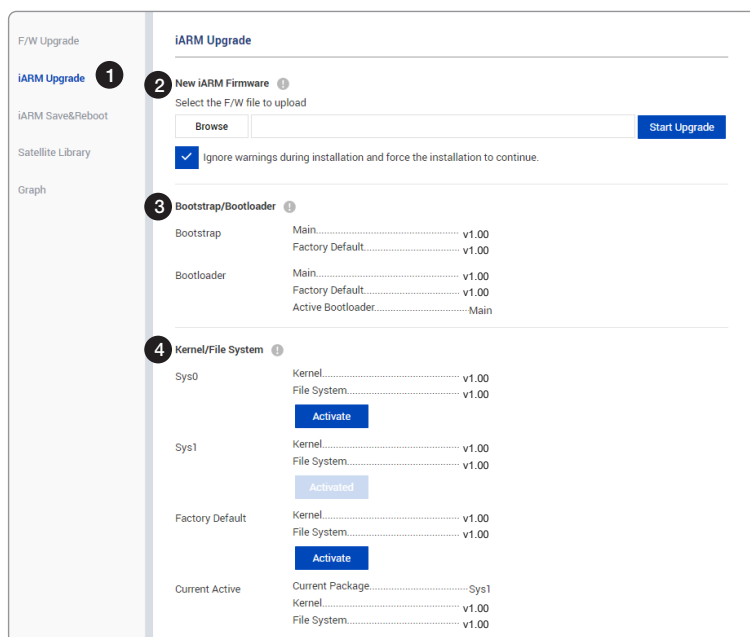

No.	Item	Description
①	iARM Upgrade	Upgrades the firmware of iARM module.
②	New iARM Firmware	<p>Browse and select the iARM firmware file to upload, and then click Start Upload button. The update may take a few minutes to complete. The upload time may vary due to a variety of factors, such as the your network speed. Uploading an incorrect firmware file may cause serious damage to your antenna and ACU. Check the firmware version before uploading firmware.</p> <p>NOTE: refer to the following "iARM Upgrade Procedures" page for more details.</p>
③	Bootstrap/Bootloader	<p>Displays current bootstrap and bootloader version.</p> <ul style="list-style-type: none"> • Bootstrap: Displays the Bootstrap Version (Main, Factory Default). • Bootloader: Displays the Bootloader Version (Main, Factory Default, Active Bootloader)
④	Kernel/File System	<p>The ACU has three storage partitions: the Sys0, the Sys1 and the Factory Default. Select the desired storage partition and click the Activate button. The currently active partition is unavailable for selection. Then perform the "9.8.3 iARM Save & Reboot" on page 91 to apply the settings to the system.</p> <ul style="list-style-type: none"> • Sys0: Displays the Sys0 version. • Sys1: Displays the Sys1 version. • Factory Default: Displays the Factory Default version. <p>The Current Active displays activated storage part Information.</p> <ul style="list-style-type: none"> • Current Active <ul style="list-style-type: none"> - Current Package: Displays the activated storage partition name (Sys0, Sys1 or Factory Default). - Kernel, File System: Displays the activated storage part's file version.

iARM Upgrade Procedure

1. Browse and , in the Windows Open dialog box, select the iARM firmware file (.tgz) that you wish to upgrade.
2. Click **Start Update** button to update the iARM firmware. Wait until the page is loaded.



NOTE

When selecting the box "Ignore warnings during installation and force the installation to continue" before performing the upgrade, the warning messages do not appear during the upgrade.

Once the update starts, the update process will be displayed on the screen. It will take about two minutes to complete the firmware upgrade.



WARNING

Do not turn off the device power if the firmware upgrade page is displayed. Failure to comply may lead to damage and/or malfunction of the system.

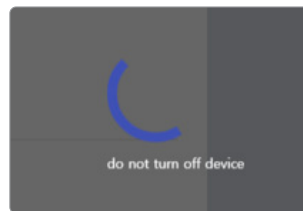

Once the upgrade is completed, the iARM module will automatically reboot in 10 seconds.

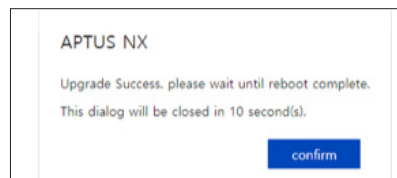

9.8.3 iARM Save & Reboot

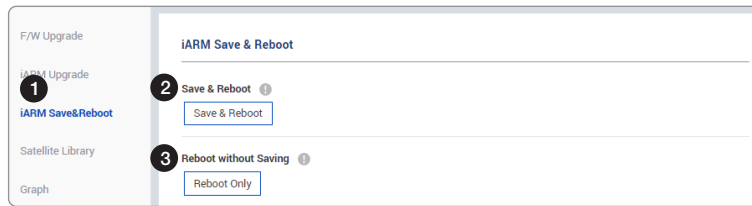

No.	Item	Description
①	iARM Save & Reboot	Saves settings to the ACU and reboot or reboot the system without saving.
②	Save & Reboot	Saves the modified settings, and reboots the iARM. All configuration changes made will be saved in the ACU and effective upon reboot. Click the Save & Reboot button.
③	Reboot without Saving	Reboots the iARM without saving the modified settings. All configuration changes made will be lost upon reboot. Click the Reboot Only button.

9.8.4 Satellite Library

The screenshot shows the 'Satellite Library' configuration window. On the left sidebar, 'Satellite Library' is highlighted with a circled '1'. The main area is titled 'Satellite Library' and contains a 'Satellite List' (2) with a scrollable list of satellites: THAICOM5 / 78.5E (selected), ST2 / 88E, MEASAT_M / 91.5E, and KORSAT_6 / 116E. To the right of the list are four buttons: 'Get Library from ACU', 'Save to PC(Download)', 'Get Library from PC', and 'Save to ACU'. Below the list is a 'Common Information' section (4) with fields for Satellite Name (THAICOM5), Longitude (78.5), Skew Offset (0), and Identify (DVB Lock). Below that is a 'DVB Information' section (3) with fields for Frequency (12272), Symbol (30000), NID (0x0058), and Verify Type (DVB Decode). At the bottom is an 'NBD Information' section (6) with fields for Frequency (972000), Bandwidth (1000), and Base Local (11300). A 'Load Satellite' button is located at the bottom center of the form.

No.	Item	Description
①	Satellite Library	Edits the satellite library information.
②	Satellite List	<p>Reads or manages satellite information from the library.</p> <ul style="list-style-type: none"> • Get Library from ACU: Obtains satellite library file from the ACU. • Get Library from PC: Obtains the satellite library file from the PC. • Save to PC (Download): Saves the current library file to the PC. • Save to ACU: Saves the current library file to the ACU.
③	Satellite Information	Select one of the satellites in the Satellite List then Click the Load Satellite button to load the satellite information.
④	Common Information	<p>Displays selected satellite information.</p> <ul style="list-style-type: none"> • Satellite Name: Displays the satellite name. • Longitude(°): Displays satellite orbit position. • Skew Offset: Displays the Skew offset. • Identify: Displays the lock setting type (Modem Lock / DVB Lock) for satellite tracking. • Rx Polarization: Displays the current Rx polarization. • Tx Polarization: Displays the current Tx polarization.
⑤	DVB Information	<p>Displays DVB mode's tracking information.</p> <ul style="list-style-type: none"> • Frequency (MHz): Displays the tracking frequency. • Symbol (kSps): Displays the symbol rate. • NID: Displays the network ID. • Verify Type: Displays the verification type.
⑥	NBD Information	<p>Displays NBD mode's tracking information.</p> <ul style="list-style-type: none"> • Frequency (kHz_IF): Displays the tracking frequency. • Bandwidth (kHz): Displays the detection bandwidth. • Base Local (MHz): Displays the base local.

9.8.5 Graph



Single Chart View

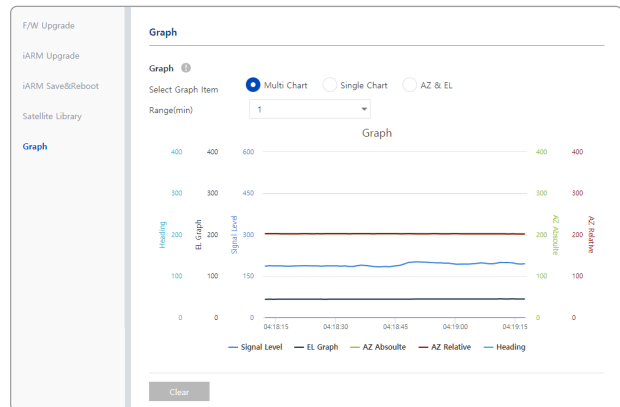

Multi Chart View

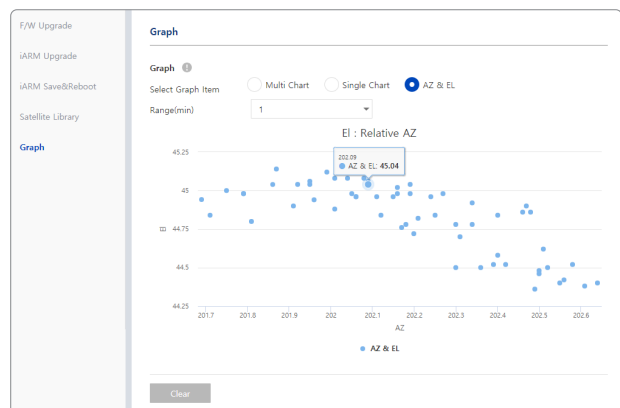

AZ & EL View

No.	Item	Description
①	Graph	This view provides information on the Signal Level, EL Graph, AZ Absolute, AZ Relative, Heading in the Multi Chart, Single Chart or AZ & EL formats.
②	Graph	<p>Sets detailed options for the graph.</p> <ul style="list-style-type: none"> • Select Graph Item: Shows the graphs of only the checked item(s) in the Multi Chart, Single Chart or AZ & EL formats. <ul style="list-style-type: none"> - Multi Chart: Displays multiple graph Items in one graph view. - Single Chart: Displays the checked graph Item in each graph view. - AZ & EL: Displays the AZ / EL angle value in one graph view. • Range (min): Displays the data for the set time. <p>By clicking the Clear button, the currently displayed graph is cleared and a new graph is displayed.</p>

9.9 System Troubleshooting

This menu sets and displays the Diagnosis, Antenna Log, Antenna Event Log and Support function.

9.9.1 Diagnosis

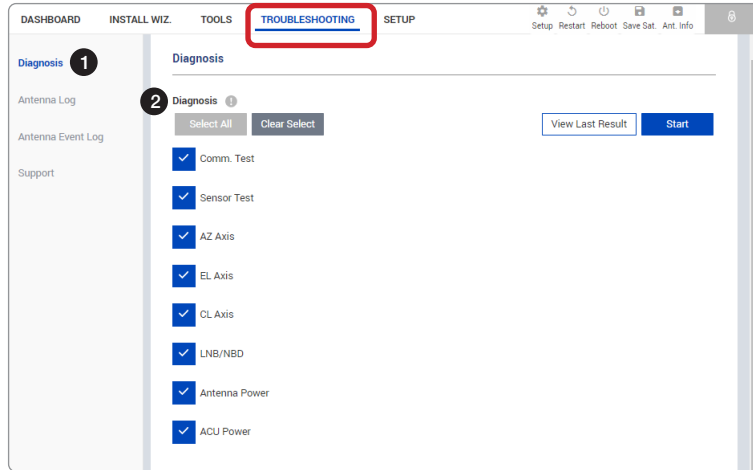

No.	Item	Description
①	Diagnosis	Executes antenna diagnosis test to check the antenna status.
②	Diagnosis	<p>Select the checkbox for each test that you want to run on the system. You can select all the tests quickly by selecting the top checkbox.</p> <ul style="list-style-type: none"> • Select All: Select to run a full diagnosis test. • Clear Select: Select to run a single diagnosis test. • View Last Result: Displays the recently saved diagnosis result. • Start: Executes the diagnosis test.

Diagnosis Procedures:

1. Select the checkbox for each test that you want to run on the system. Click the **Start** button to run the diagnostic test.

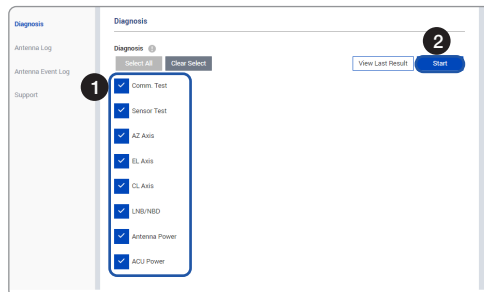

Once the diagnosis starts, the page will indicate test status. It will take a few minutes to complete the test.

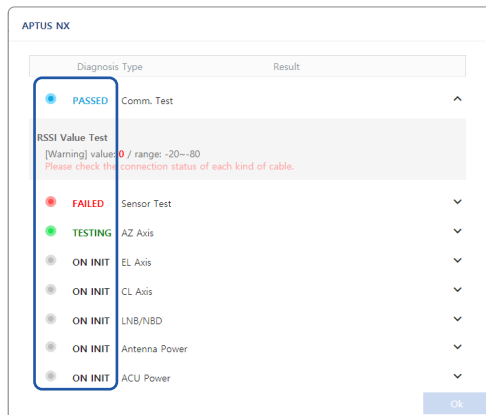

After the diagnosis is completed the system shows the diagnosis results of each item.

- You can save the results to the ACU by clicking the **Save Report** button and print this page by clicking the **Print** button.

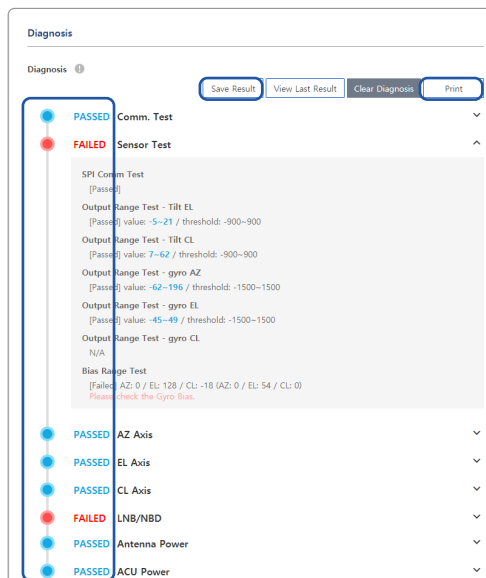

- When you want to check the recently saved diagnosis results, click the **View Last Report** button. The pop-up page of the diagnosis results, including the save date and time, will appear. You can print this page by clicking the **Print** button.

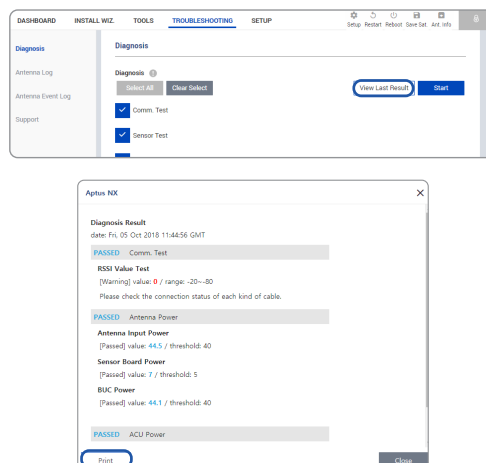

9.9.2 Antenna Log

Date/Time (UTC 00:00)	STAB	PCU	Main
Wed, 25 Jul 2018 06:16:13	0.94 Success	0.94 Success	0.94 Success

No.	Item	Description
①	Antenna Log	Displays the antenna log data.
②	GPS Log Option	Turns on/off the GPS log download option. Click the Apply button to apply the settings to the system.
③	Antenna Log Download	Any log data within three months can be downloaded. Select the duration on the calendar view that you want to show. Then click the Start Download button. NOTE: When selecting the box Include Backup/Report File before downloading, the Backup/Report File will download together. When selecting the box Compress before downloading, log files are downloaded in a compressed format.
④	Antenna F/W Log	Displays log information about firmware upgrade.

9.9.3 Antenna Event Log

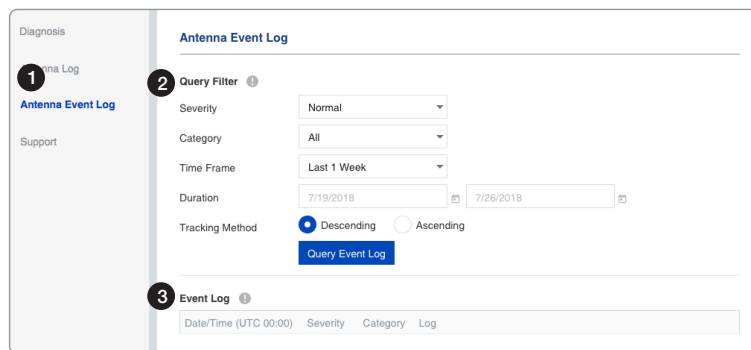

No.	Item	Description
①	Antenna Event Log	Displays the logged events of the antenna system filtered by the urgency level, category and time frame of the events.
②	Query Filter	<p>Sets the filter options to show the logged events.</p> <ul style="list-style-type: none"> Severity: Choose the urgency level of event to show. Category: Choose the event category to show. Time Frame: Choose the time frame of event log to show. Duration: Set the duration by selecting start and end dates in the calendar. Tracking Method: Select the sorting method (Descending / Ascending). <p>Click the Query Event Log button to show the logged events under the Event Log.</p>
③	Event Log	Displays the list of logged events filtered by the Query Filter options in the previous step.

9.9.4 Support

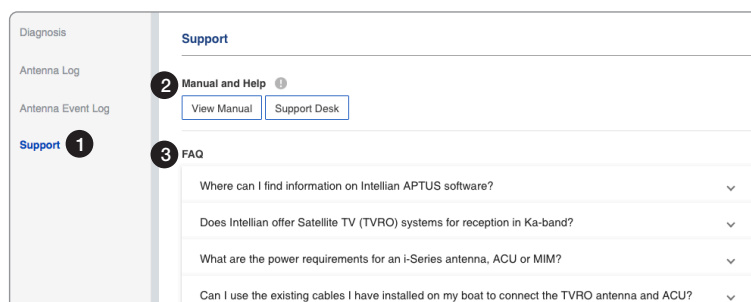

No.	Item	Description
①	Support	Supports the manual web page, support desk and FAQ list.
②	Manual and Help	<p>Shows the manual web page and support desk information.</p> <ul style="list-style-type: none"> View Manual: Click the View Manual button to open the manual web page. Support Desk: Click the Support Desk button to open Intellian's contact details for support.
③	FAQ	Provides answers for frequently asked questions about the product.

9.10 System Setting

This menu sets and displays the Ship, Antenna, Satellite, Network, Modem/BUC, SNMP, Backup & Restore and Mediator function.

9.10.1 Ship Setting

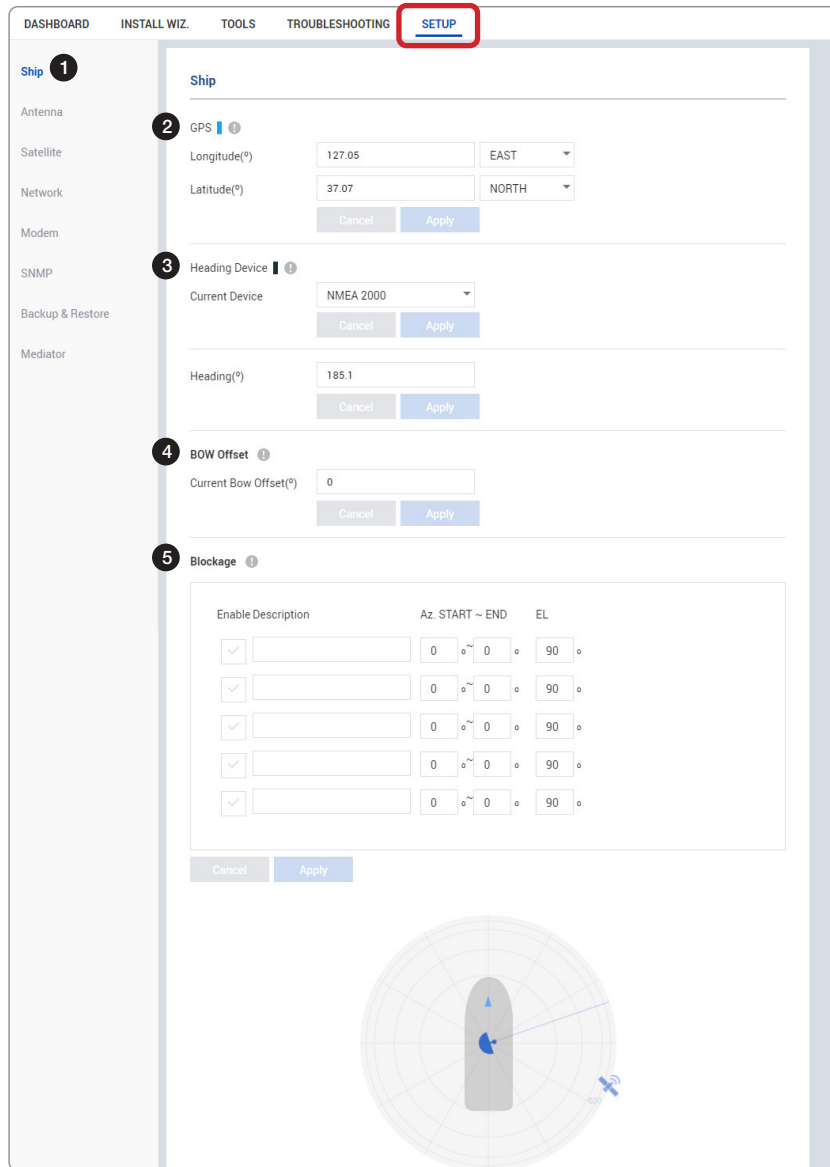

No.	Item	Description
①	Ship	Sets the ship information and blockage zones.
②	GPS	<p>Sets the GPS position of the vessel for searching for a satellite. Check the GPS status connected to the antenna system. The indicator to the left of the help button shows the GPS status. Make sure the GPS indicator is Blue (blinking). (Blue (blinking): the system received a correct GPS input. Black: the system has not received a GPS input. You can enter the GPS value manually to set the GPS position.)</p> <ul style="list-style-type: none"> • Longitude (°): Set Longitude information (East / West). • Latitude (°): Set Latitude information (North / South). <p>Click the Apply button to apply the settings to the system.</p>

No.	Item	Description
③	Heading Device	<p>Sets the ship's heading device. Choose the device type from the Current Device drop-down list. The indicator to the left of the help button shows the device connection status. (Blue: a ship's heading device is connected. Black: a ship's heading device is not connected.)</p> <ul style="list-style-type: none"> • Current Device: Select the heading device (None, NMEA, NMEA 2000, Static). If you select NMEA, you can also set the Baud Rate. • Baud Rate: Select the band rate (4800, 9600, 19200, 38400). When NMEA is selected on the Current Device list, this item appears. • Sentence: Displays the sentence information. When NMEA is selected on the Current Device list, this item appears. • Heading(°): Enter the heading information. <p>Click the Apply button to apply the settings to the system.</p>
④	BOW Offset	<p>For setting the bow offset, you need to select a satellite which is trackable in satellite library information. When the antenna tracks the selected satellite, bow offset will be set up automatically.</p> <ul style="list-style-type: none"> • Current Bow Offset(°): Enter the Bow Offset Range: 0 – 360°. <p>Click the Apply button to apply the settings to the system.</p>
⑤	Blockage	<p>It is important to set up the blockage zones for Intellian VSAT. The VSAT system can be programmed with relative azimuth and elevation sectors to create up to five zones where transmission is muted.</p> <p>When the antenna is within one of the zones, a transmit inhibit output from the ACU will disable/mute the modem transmission within the blockage zones.</p> <p>The AZ START is the relative azimuth angle where the blockage starts, and the AZ END is the relative azimuth where the blockage ends (Range: 0 ~ 360).</p> <p>The EL is the elevation angle where the blockage is set (Range: 0 ~ 90). The blockage is activated below the elevation angle.</p> <p>Click the Apply button to apply the settings to the system.</p>

9.10.2 Antenna Setting

The screenshot shows the 'Antenna Setting' configuration page. It is divided into several sections, each with a numbered callout:

- 1** **Antenna**: The main menu item on the left sidebar.
- 2** **Antenna Angle**: Contains fields for Relative Azimuth (125.76°), Absolute Azimuth (310.86° / 294.42°), and Elevation (42.33° / -35.85°). Each field has a numeric input and a +/- button.
- 3** **Tracking / Searching Parameter**: Includes 'Thresholds Setting' with fields for Detect Level (40), Tracking Level (20), and Tx Enable (50).
- 4** **Search Parameter**: Includes 'Wait Time(sec)' (5), 'Search Step(°)' (0.5), and a table for search parameters:

	Search1	Search2	Search3
Azimuth(°)	400	6	3
Elevation(°)	8	6	4
- 5** **Conical Range**: Includes fields for Azimuth (80) and Elevation (60).
- 6** **Conical Range Check**: Includes a 'Switch Activation' toggle (On) and a table:

AZ	EL
24	24
24	25
25	25
23	25
24	25
- 7** **Sensor Calibration**: Includes 'EI Adjust' (2.5).
- 8** **Tilt Sensor Bias**: Includes a 'Ready' button and fields for EL (-1) and CL (0.6).
- 9** **Rate Sensor Bias**: Includes fields for Azimuth (-89), Elevation (44), and Cross-level (158). A red dashed box highlights the 'Set RateSensor Bias' button, with a red arrow pointing to it from the word 'NOTE'.
- 10** **Antenna Mode**: Includes 'Set Idle Mode' and 'Reboot' buttons.



NOTE

The "Set Rate Sensor Bias" function must be used by experienced engineers only.

No.	Item	Description
①	Antenna Setting	Sets current antenna position and search parameters. These parameters should only be changed by an authorized service technician. Improper setting of these parameters will render your system inoperable.

No.	Item	Description
②	Antenna Angle	<p>The system must be in Setup Mode to modify these settings.</p> <p>Sets current antenna position and LNB pol angle. You can move the antenna's azimuth and elevation position and LNB pol angle by using the arrows or inputting a value to find the desired satellite manually.</p> <ul style="list-style-type: none"> • Relative Azimuth: Displays the antenna's relative azimuth angle. • Absolute Azimuth: Adjust the antenna's absolute azimuth angle. • Elevation: Adjust the elevation angle.
③	Thresholds Setting	<p>Sets current detect level threshold and tracking level threshold.</p> <ul style="list-style-type: none"> • Detect Level: Enter the current detect level threshold. • Tracking Level: Enter the current tracking level threshold. • Tx Enable: Enter the Tx enable threshold. <p>Click the Apply button to apply the settings to the system.</p>
④	Search Parameter	<p>Sets the timeout, search step and search range.</p> <ul style="list-style-type: none"> • Wait Time (sec): Set the time-out for automatic initiation of a search after the signal level drops below the pre-defined threshold value. • Search Step(°): Set increment step size. • Search1/3: Set Search 1 and 3 search range. Search is conducted in a two-axis pattern consisting of alternate movements in azimuth and elevation to form an expanding square. • Search2: It is reserved for the future use. <p>Click the Apply button to apply the settings to the system.</p>
⑤	Conical Range	<p>The relative force of the motors controlling azimuth and elevation. Sets the conical range while the antenna is in tracking mode.</p> <p>Click the Apply button to apply the settings to the system.</p>
⑥	Conical Range Check	<p>The system must be in Setup Mode to modify these settings. Monitors the Azimuth and the elevation values when the conical range is modified.</p> <ul style="list-style-type: none"> • Switch Activation: Choose whether to use the switch activation function (On / Off). <p>Click the Apply button to apply the settings to the system.</p>
⑦	Sensor Calibration	<p>Enter Setup Mode to modify settings.</p> <p>Adjusts the elevation to offset the angle difference between the mechanical elevation angle and actual elevation angle.</p> <p>Click the Apply button to apply the settings to the system.</p>
⑧	Tilt Sensor Bias	<p>NOTE: The tilt values of the elevation and cross-level axes were calibrated to the optimal condition at the factory prior to shipment. However, when the antenna MCU unit or fixed sensor unit is replaced, the elevation and the cross-level axes must be checked by adjusting tilt and rate sensor value. Refer to the replacement manual for detailed procedures. The separate device (e.g. level indicator) for manual adjustment is not provided by Intellian.</p> <p>Enter Setup Mode to modify settings.</p> <p>Maintain the elevation and the cross-level axes to keep the pedestal parallel to the horizon.</p> <ul style="list-style-type: none"> • Ready: Click the Ready button to bring the elevation and cross-level to 0. • EL/CL: Select EL/CL and click the Up and Down arrow keys to adjust the elevation and cross-level. <p>Click the Restart button on the top menu to restart the antenna system.</p>

No.	Item	Description
⑨	Rate Sensor Bias	<p>NOTE: The rate values of the azimuth, elevation, and cross-level axes were calibrated to the optimal condition at the factory prior to shipment. If additional rate adjustment is required, make sure that the antenna is placed on a rigid and flat platform. During the calibration process, the antenna must avoid any motion as it can affect the antenna's performance.</p> <p>Enter Setup Mode to modify settings manually.</p> <p>Calibrates DC voltage output from the three rate sensors used to sense antenna motion in azimuth, elevation and cross-level axes. These are used to sense antenna motion that corresponds to the ship's motion (roll, pitch, and yaw) for stabilizing the pedestal. The DC voltage output from each of the rate sensors may vary by an amount which is directly proportional to the direction and rate of motion induced on it.</p> <ul style="list-style-type: none"> • Rate Sensor Calibration: click the Rate Sensor Calibration button to calibrate the rate sensor automatically. The indicator to the left of the help button shows the rate sensor calibration status. (Black: The calibration is ready to start. Blue: the calibration is completed. Red: The calibration failed. Green: The calibration is in process.) • Save Sensor Bias: click the Save Sensor Bias button to save the calibrated value of the rate sensor to the system.
⑩	Antenna Mode	<p>Sets the motor to idle mode to check the antenna's balance.</p> <ul style="list-style-type: none"> • Set Idle Mode: The system must be in Setup Mode to modify this setting. Releases the elevation and cross-level motor. • Reboot: Reboots the system.

9.10.3 Tracking Satellite Setting

No.	Item	Description
①	Tracking Satellite Setting	Sets the current tracking satellite settings.
②	Satellite Information	<p>Sets the current tracking satellite settings.</p> <ul style="list-style-type: none"> • Satellite Name: Enter the satellite name. • Longitude (°): Enter the satellite orbit position. • Local Frequency (MHz): Select the local frequency. • Rx Polarization: Select the current Rx polarization. • Tx Polarization: Select the current Tx polarization. • Identify: Select the lock setting type (Modem Lock or DVB Lock) for satellite tracking. <p>Click the Apply button to apply the settings to the system.</p>
③	NBD Information	<p>Sets NBD mode's tracking information.</p> <ul style="list-style-type: none"> • Frequency (kHz_IF): Set the tracking frequency. • Reserved Parameter(kHz): Set the reserved parameter. <p>Click the Apply button to apply the settings to the system.</p>
④	Eutel Satellite	<p>Select ON when the antenna is tracking the Eutelsat satellite. With this option enabled, a defined skew angle for each Eutelsat satellite is automatically applied without allowing a manual modification to the skew offset value.</p> <p>Click the Apply button to apply the settings to the system.</p>
⑤	Modem Lock Use for Verification	<p>Verifies modem lock status (modem lock function: active/inactive).</p> <ul style="list-style-type: none"> • Modem Verify: Turn on or off the modem lock function (On / Off) <p>Click the Apply button to apply the settings to the system.</p>

9.10.4 Network Configuration

This function is available after performing the "9.8.3 iARM Save & Reboot" on page 91.

The screenshot shows the 'Network Configuration' page with the following sections:

- 1 Network Configuration:** IP Address (192.168.2.1), Subnet Mask (255.255.255.0), Lease Start Address (192.168.2.2), Lease End Address (192.168.2.30), Lease Time (min) (180).
- 2 Management Interface Configuration:** AP (Disable/Enable), SSID (intellian-NX), Channel (6), Authentication Type (Open), Password (.....), Max Stations (10), SSID Broadcast (Disable/Enable).
- 3 WiFi Access Point Configuration:** Telnet Service (Disable/Enable), HTTPS Port (443), SSH Service (Disable/Enable).
- 4 Network Service Configuration:** Management Server (No/Yes), Server IP (192.168.1.1), UDP Port (514), Message Type (Error, Major, Minor, Diagnosis, Periodic, Special, Setting, Notice), Syslog Target Level (LOG NOTICE).
- 5 Sys Log Configuration:** Client (Disable/Enable), Server IP (192.168.1.10), Timeout (5), Server Secret (testing123).

No.	Item	Description
①	Network Configuration	Sets the ACU's Internal IP address and ports.

No.	Item	Description
②	Management Interface Configuration	<p>Sets the Management Port's network configuration. The Management Port is located on the ACU front panel.</p> <ul style="list-style-type: none"> • IP Address: Set the network IP address (Factory default: 192.168.2.1). • Subnet Mask: Set the subnet mask (Factory default: 255.255.255.0). • Lease Start Address: Set the lease IP address start range. DHCP will only assign IP addresses within the start and end range. • Lease End Address: Set the lease IP address end range. • Lease Time: Set the lease IP address update time. This is the amount of time in seconds (default 604800 seconds or 7 days) that an IP address is reserved for a network device. <p>Click the Apply button to apply the settings to the system.</p>
③	Wi-Fi Access Point Configuration	<p>Set up for the Wi-Fi access point function of ACU.</p> <ul style="list-style-type: none"> • AP: Enable or disable the Access Point (AP) function. • SSID: The SSID is the name that allows devices to identify and connect to the wireless network. The SSID is case-sensitive and must not exceed 32 alphanumeric characters, and it can be any keyboard character. The SSID is the same for all devices that connect to your wireless network. • Channel: Select an appropriate channel from the list provided to correspond with your network settings. All devices that connect to your wireless network will use the same channel automatically. Try to avoid conflicts with other wireless networks by choosing a channel where the upper and lower three channels are not in use. • Authentication Type: The module supports an authentication mode that the 802.11 device uses when it authenticates and associates with an access point or IBSS cell. • Password: Set the password for Wi-Fi access point. • Max Stations: Enter the maximum number of stations. • SSID Broadcast: Enable or disable the SSID broadcast function. <p>Click the Apply button to apply the settings to the system.</p>
④	Network Service Configuration	<p>Sets the network service configuration</p> <ul style="list-style-type: none"> • Telnet Service: Sets the telnet service (Disable / Enable). • HTTPS Port: Sets the HTTPS port number. • SSH Service: Sets the SSH service status (Disable / Enable). <p>Click the Apply button to apply the settings to the system.</p>
⑤	Sys Log Configuration	<p>Sets the system log configuration. Antenna sends log messages according to the emergency level. Enabling this function sends the message to your management server.</p> <ul style="list-style-type: none"> • Management Server: Sets the management server status (No / Yes). • Server IP: Sets the management server IP address. • UDP Port: Sets the management port. • Message Type: Selects message type (Intellian message level) to send to the management server (Lower number indicates higher emergency). • Syslog Target Level: If you select this target level, the management server receives a log message equal to or less than this level. <p>Click the Apply button to apply the settings to the system.</p>

No.	Item	Description
⑥	Radius Configuration	<p><i>This menu is used when the network administrator needs to authorize user connections using Radius server.</i></p> <ul style="list-style-type: none"> • Client: Sets the Radius authentication (Disable / Enable). • Server IP: Sets the Radius server IP Address. • Timeout: Sets the Timeout value in seconds for the authentication process. • Server Secret: Sets the Pass-Phase. This should be matched between server and ACU. <p>Click the Apply button to apply the settings to the system.</p>



NOTE

When clicking the **Apply** button after editing the system settings, this pop-up message will appear. If you want to automatically save and reboot the system, select the checkbox and click the **Confirm** button.

APTUS NX

All configuration changes made will be saved in the ACU and effective upon reboot.

Automatically Save&Reboot upon apply.

9.10.5 Modem/BUC Setting

No.	Item	Description
①	Modem Setting	Sets the modem interface.
②	Modem	<p>Sets the interface between the ACU and the satellite modem.</p> <ul style="list-style-type: none"> • Select Modem: Select your modem type from the Select Modem drop-down list for loading a pre-configuration for the type of modem used. The settings related to the modem interface will be set automatically once the modem type is selected. When you select USER SETTING the other settings can be changed independently. • Modem Port: Select a proper data communication port of the ACU for the satellite modem interface. • Modem Protocol: Select a proper communication protocol of the ACU for the modem interface. • GPS Out Sentence: Select the GPS out sentence type. • Use Tx Mute: Select whether you use the Tx Mute function for the modem or not. • Use Modem Lock: Select whether you use Modem Lock function for the modem or not. • Tx Mute: This function can be edited when User Setting option is selected in the Select Modem menu. It selects the Tx Mute option. The Tx Mute is a transmit inhibit output from the ACU to disable/mute the modem transmit through a 5 V (HIGH) or 0 V (LOW) current whenever the antenna is blocked, searching, or pointed 0.5 degrees off from peak satellite position. • Modem Lock: This function can be edited when User Setting option is selected in the Select Modem menu. It selects the Modem Lock option. The Modem Lock provides a logic input through a 5 V (HIGH) or 0 V (LOW) current to the ACU to identify when the system is on the correct satellite. <p>Click the Apply button to apply the settings to the system.</p>

No.	Item	Description
③	Modem Port Configuration	<p>This function is available after performing the "9.8.3 iARM Save & Reboot" on page 91.</p> <p>Sets the ACU's internal IP address, routing, and ports.</p> <ul style="list-style-type: none">• IP Address: Enter the network IP address.• Subnet Mask: Enter the subnet mask.• Gateway: Enter the gateway.• DNS: Enter the current default DNS address.• NAT Routing: Select the NAT routing (Enable / Disable).• TCP Modem Protocol Port: Enter the TCP port number for modem protocols using TCP as transport.• UDP Modem Protocol Port: Enter the UDP port number for modem protocols using UDP as transport. <p>Click the Apply button to apply the settings to the system.</p>

9.10.6 SNMP Setting

No.	Item	Description
①	SNMP Setting	Sets SNMP configuration.
②	SNMP Agent Configuration	<p>Sets the SNMP configuration.</p> <ul style="list-style-type: none"> • SNMP V1/V2 Status: Choose the SNMP mode. • V1/V2 Community Name: Enter the SNMP V2 community name. • V3 Authentication Type: Enter the SNMP V3 authentication mode. • V3 Authentication Encoding: Choose the SNMP V3 authentication encoding. • V3 Username: Enter the V3 username of the SNMP Agent. • V3 Password: Set the V3 password of the SNMP agent. The password must be at least eight character long. • V3 Private Encoding: Choose the SNMP V3 private encoding. • V3 Private Password: Set the V3 private password. The password is must be at least eight character long. • TRAP IP/Port: Enter the TRAP IP/Port. • TRAP Parameter: Enter the SNMP trap specific parameter. <p>Click the Apply button to apply the settings to the system. Then perform the "9.8.3 iARM Save & Reboot" on page 91.</p>

9.10.7 Backup & Restore Setting

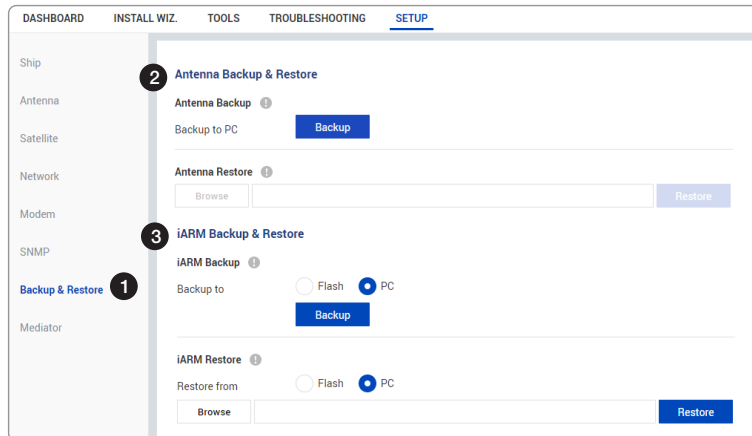

No.	Item	Description
①	Backup & Restore Setting	Backs up & Restores the antenna setting files and the iARM files.
②	Antenna Backup & Restore	<ul style="list-style-type: none"> Antenna Backup: Back up antenna settings and parameters to PC by clicking on the Backup button. Antenna Restore: Restore the antenna setting by uploading the saved backup file from PC. Browse the backup file, then click the Restore button to restore it.
③	iARM Backup & Restore	<ul style="list-style-type: none"> iARM Backup: Back up iARM setting to internal Flash drive in ACU or PC by clicking the Backup button. iARM Restore: Restore the iARM settings by uploading the saved backup file from internal Flash drive in ACU or PC. Browse the backup file, then click the Restore button to restore it.

9.10.8 Mediator Setting for Dual Antenna System (Optional)

This function is available when using the Dual Antenna System.

Refer to "**12.2 Appendix B. Starting Dual Antenna System (Optional)**" on page 117 for more detail.

Figure 34: Mediator Setting for Primary Antenna

Figure 35: Mediator Setting for Secondary Antenna

No.	Item	Description
①	Mediator Setting	Intellian's new ACU has embedded Dual Antenna Mediator function, which can be utilized to switch between two Intellian VSAT antenna systems simultaneously. When one antenna is blocked by obstacles or has sudden service loss, another antenna immediately provides fail-safe operation to maintain the high leveled system performance.
②	Mediator	<p>Enable or disable the dual antenna mediator function.</p> <ul style="list-style-type: none"> • Yes: Enables the mediator function to use the Dual Antenna System. The submenu is shown for detailed function settings. • No: Disables the mediator function. <p>Click the Apply button to apply the settings to the system. Then perform the "9.8.3 iARM Save & Reboot" on page 91.</p>
③	Antenna Active	<p>This function is available in the Primary Antenna's AptusNX when both Primary Role's ACU and Secondary Role's ACU are connected to the system.</p> <p>Sets the method for selecting the active antenna. The active antenna (either primary or secondary antenna) is communicating (Tx/Rx) with a satellite.</p> <ul style="list-style-type: none"> • Auto: This method is recommended. Automatically switch-over to the primary or secondary antenna which has no blockages and no errors. • Primary: Manually switch-over to the primary antenna which is connected to the modem and the gyrocompass. • Secondary: Manually switch-over to the secondary antenna. <p>Click the Apply button to apply the settings to the system.</p>

No.	Item	Description
④	Antenna Description	<p>This menu is differently shown in the Primary Antenna's AptusNX and the Secondary Antenna's AptusNX.</p> <p>To clearly distinguish the primary antenna and the secondary antenna, enter a description to each antenna.</p> <ul style="list-style-type: none"> • Primary: Enter the description for the primary antenna in AptusNX (Editable). This menu is not shown for the secondary antenna in AptusNX. • Secondary: Enter the description for the secondary antenna in AptusNX (Editable). This menu is displayed as Read-only for the primary antenna in AptusNX. <p>Click the Apply button to apply the settings to the system. Then perform the "9.8.3 iARM Save & Reboot" on page 91.</p>
⑤	Switching Threshold	<p>When two antennas are in Tracking mode and have no blockage, the allowable value will apply for the automatic switching.</p> <ul style="list-style-type: none"> • Signal Level: If the signal level is less than the set value, the active antenna is automatically switched (Default: 30). • Switching Time (sec): If the signal value difference between the active antenna and inactive antenna is more than the set value which is set in the Signal Level menu and the difference is maintained for a set time, the active antenna is automatically switched. Set the switching time value (Default: 5). <p>Click the Apply button to apply the settings to the system. Then perform the "9.8.3 iARM Save & Reboot" on page 91.</p>
⑥	Role	<p>Assigns the antenna's role of the primary antenna or secondary antenna.</p> <ul style="list-style-type: none"> • Primary: When running the primary ACU, which is connected to the modem and the gyrocompass, select the primary role. The primary ACU is assigned and operated as the primary antenna, which will communicate with the target satellite. • Secondary: When running the secondary ACU, select the secondary role. The secondary ACU is assigned and operated as the secondary antenna, which will be on standby and ready to assume primary antenna role to provide better service in the event of tracking failure or low signal level status. <p>Click the Apply button to apply the settings to the system. Then perform the "9.8.3 iARM Save & Reboot" on page 91.</p>
⑦	Network to connect secondary antenna	<p>Sets the primary antenna's network information to transmit to the secondary antenna.</p> <ul style="list-style-type: none"> • Primary Server IP: Enter the server IP address (Default: 192.168.205.1). • Primary Server PORT: Set the server port number for the primary antenna and the secondary antenna, which must be the same number (Default: 50205). • IP: When the antenna role is primary, enter the same IP address with the Primary Server IP. When the antenna role is secondary, enter a different IP address from the Primary Server IP; however, it must be assigned to the same network class as the primary (Default: 192.168.205.1). • Netmask: The primary and secondary netmasks must be the same (Default: 255.255.255.0). <p>Click the Apply button to apply the settings to the system. Then, perform the "9.8.3 iARM Save & Reboot" on page 91.</p>

**CAUTION**

When using the Dual Antenna System, the IP address under the Modem Port Configuration for the Primary ACU and the Secondary ACU must be assigned differently.

Chapter 10. Specification

10.1 Technical Specification

Antenna System		
Antenna Radome Height	930 mm (36.6")	
Antenna Radome Diameter	Ø860 mm (33.9")	
Antenna Reflector Diameter	Ø650 mm (25.6")	
Antenna Unit Weight (With Radome)	39.0 kg (86.0 lbs)	
Platform	3-axis: Azimuth, Elevation, Cross-level	
Positioning	3-axis Velocity Mode Servo Control: Azimuth, Elevation, Cross-Level	
Azimuth Range	Unlimited	
Elevation Range	-20° to +115°	
Cross-level Range	Up to ±37°	
Stabilization Accuracy	0.2° max in presence of specified ship motions	
Ship's motion	Roll	±25° at 6 second
	Pitch	±15° at 6 second
	Yaw	±8° at 6 second
	Turning rate	10°/sec ²
AZ/EL/CL Motor	Brushless DC motor with Encoder	
Motor Brake System	Without Motor brake	
Sensor	3 axis Gyro-Rate Sensor & 2 axis Tilt Sensor (Fixed Sensor)	
Rx	Frequency	17.7 GHz ~ 20.2 GHz Ka-band
	Gain	Min. 40.2 dBi @ 19.0 GHz (Excl.radome)
	G/T over Rx Range	Min. 15.5 dB/K @ Elevation 10 degree
	Axial Ratio	1.7 dB on Axis
Tx	Frequency	27.5 GHz ~ 30 GHz Ka-band
	Gain	Min. 44.2 dBi @ 29.0 GHz (Excl.radome)
	EIRP	Min. 50.2 dBW @ 4.5 W Transceiver
	Axial Ratio	1.0 dB on Axis
Polarization	Circular Dual Polarization (Rx: RHCP/LHCP, TX: RHCP/LHCP)	
Transceiver	4.5W, 9W Transceiver	
ACU to ADU Cable (Antenna Cable)	Single 50 Ω coax RF cable connected from ACU to ADU for Rx, Tx, FSK, Reference and Power	
Input power	48 V DC through a single RF cable	

Antenna Control Unit (ACU)	
ACU Size	431 mm x 350 mm x 44.3 mm (16.97" x 13.78" x 1.74")
ACU Weight	5.2 kg (11.5 lbs)
Display	256 x 64 Graphic OLED
Key	Two Push Keys
LED Indicator	Three LEDs for Power, Tracking and Error
USB Port	2 ea (front panel), 1 ea (back panel, for Wi-Fi dongle)
Ship's Gyrocompass Interface	NMEA 2000, NMEA 0183 (GYRO)
GPS	NMEA Out
Serial Interface	RS232C (57600 bps 8, N, 1)
Transceiver Interface	RS422/Keyline Port (LK0080_ D SUB to RJ45 Cable)
Ethernet port	RJ45 (4 ea), TCP/IP connection
Input power	100 ~ 240 V AC, 50/60 Hz, 3.3 A

10.2 Environmental Specification

Test	Intellian Standard	
Temperature (ADE)	Operational	IEC-60945 (-25 °C to +55 °C, Power On)
	Survival	IEC-60945 (-40 °C to +80 °C, Powered On and a non-functional state)
	Storage	IEC-60945 (-40 °C to +85 °C, Power off)
Temperature (ACU)	Operational	IEC-60945 (-15 °C to +55 °C)
	Survival	IEC-60945 (-25 °C to +70 °C)
	Storage	IEC-60945 (-40 °C to +85 °C)
Wind	56 m/sec (125 mph)	
Humidity	IEC-60068-2-30 Upper Test Temp: +40 °C (-3), Humidity 98 % Lower Test Temp.: +15 °C (+3), Humidity 71 % ~ 78 %	
Vibration	Operational	IEC-60945
	Survival	IEC-60721-3-6 Class 6M3 DNV Standard No. 2.4, Class C
Shock	Operational	IEC-60068-2-27 Method Ea 20g, 7ms
	Survival (Transient)	IEC-60721-3-6 Class 6M3 type II 30g, 6ms
	Survival (Bump)	IEC-60068-2-29 Method Eb 25g, 6ms
Salt mist	Saline solution : 5 ±1 % NaCl Storage period: 7 Days (IEC-60945)	
Waterproofing	IPX6 (IEC-60529)	
Solar	IEC 60945-Annex B. Operational +32 °C air temperature with the addition of 670 Watt/m ² solar radiation	

Chapter 11. Warranty

Warranty Policy

Intellian systems are warranted against defects in parts and workmanship. These warranties cover THREE (3) YEAR of parts and TWO (2) YEAR of factory repair labor to return the system to its original operational specification.

Warranty periods commence from the date of shipment from Intellian facility or date of installation, whichever is sooner. The warranty provides a maximum of 6 months additional coverage if you submit an authorized form describing the installation within 6 months of the shipment date.

Intellian Technologies warranty does not apply to a product that has been damaged and subjected to accident, abuse, misuse, non-authorized modification, incorrect and/or non-authorized service, or to a product on which the serial number has been altered, mutilated or removed. Intellian Technologies, will (at its sole discretion) repair or replace during the warranty period any product which is proven to be defective in materials or workmanship, in accordance with the relevant product warranty policy. All products returned to Intellian Technologies during the warranty period must be accompanied by a Service Case reference number issued by the dealer/distributor from Intellian Technologies, and (where applicable) a copy of the purchase receipt as a proof of purchase date, prior to shipment. Alternatively, you may bring the product to an authorized Intellian Technologies dealer/distributor for repair.

Chapter 12. Appendix

12.1 Appendix A. Tightening Torque Specification

This table shows the recommended values of tightening torques.

Bolt Size	Tightening Torque (N-m)
M2	0.5
M2.5	1
M3	1.5
M4	3
M5	6
M6	12
M8	27
M10	50
M12	85
M14	130
M16	200

12.2 Appendix B. Starting Dual Antenna System (Optional)

Intellian ACU has the embedded Dual Antenna Mediator function, which is used to instantly switch between two Intellian VSAT antenna systems. When one antenna is blocked by obstacles or has suddenly lost service, another antenna will immediately provide a fail-safe operation to maintain the highest levels of system performance and reliability. This ensures always-on broadband service by reducing the out of service time.

12.2.1 Configuration of Dual Antenna System

To use the Dual Antenna System, make sure the antenna system components are properly installed. Refer to "6.4.2 Dual Antenna System Configuration (Optional)" on page 39 for more details.

12.2.2 Setting Up Dual Antenna System

To establish Dual Antenna System communication between the primary and secondary antennas, follow the steps below.

Connecting Ethernet Cable

Connect an Ethernet cable from the Management LAN port on the front of the Primary/Secondary ACU to the LAN port of PC. The connection network is established.

Process to Set Up Dual Antenna System

The following flow chart shows the process of establishing the Dual Antenna System.

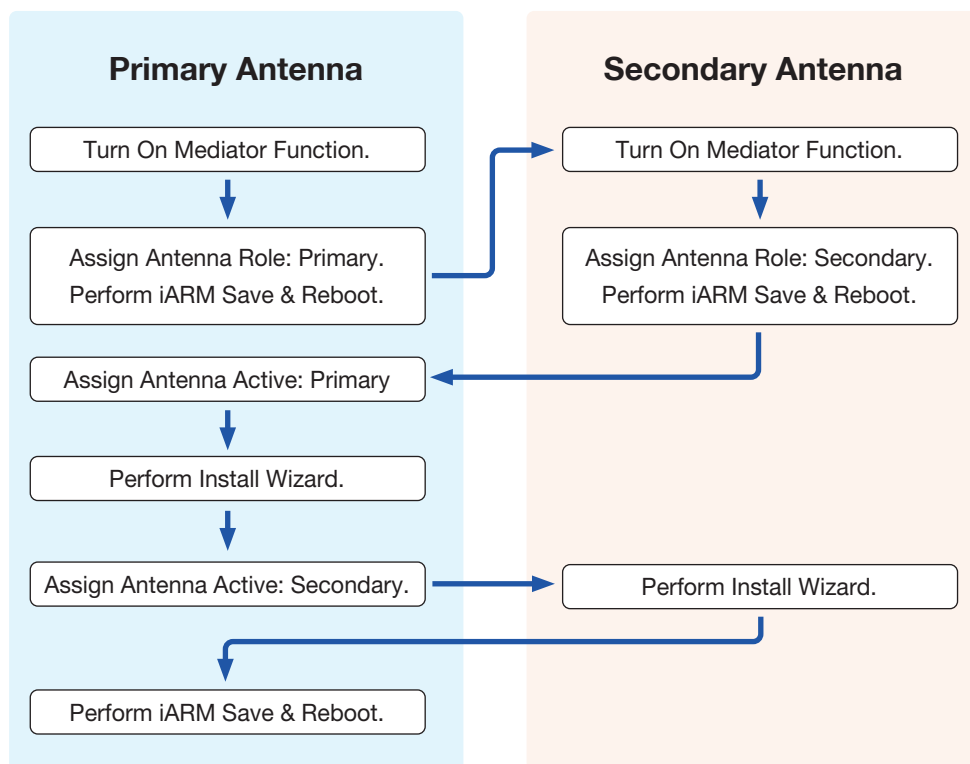
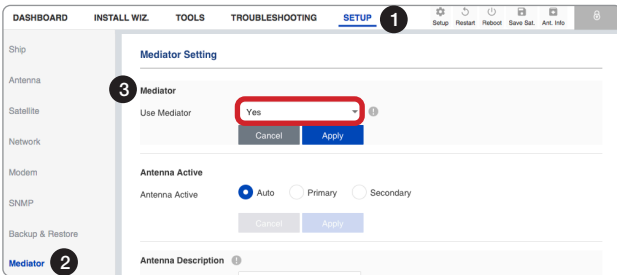

Figure 36: Flow Chart of Establishing Dual Antenna System

Assigning Antenna Role

Access the AptusNX (IP Address: 192.168.2.1) to manage and control the Dual Antenna System. Go to **SETUP > Mediator > Mediator Setting**. Select the **Yes** for the **Use Mediator** option.



1. Assigning Primary Antenna Role

When connecting the primary ACU, which is connected to the modem and the gyrocompass, select **"Primary"** for the **Role** option. The primary ACU is assigned and operated as the primary antenna, which communicates with the target satellite. Click the **Apply** button to apply the settings to the system. Then perform **"9.8.3 iARM Save & Reboot"** on page 91.

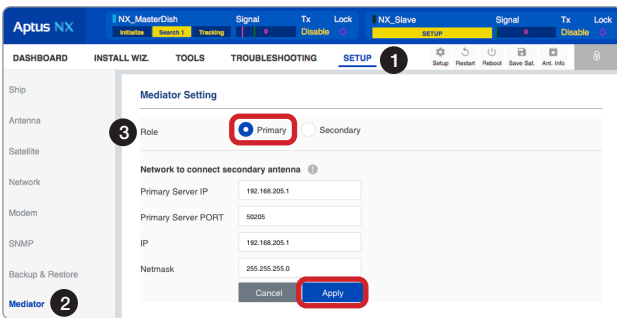

2. Assigning Secondary Antenna Role

When connecting the secondary ACU, select **"Secondary"** for the **Role** option. The secondary ACU is assigned and operated as the secondary antenna, which will be on standby and ready to assume primary antenna role to provide better service in the event of tracking failure or low signal level status. Click the **Apply** button to apply the settings to the system. Then perform **"9.8.3 iARM Save & Reboot"** on page 91.

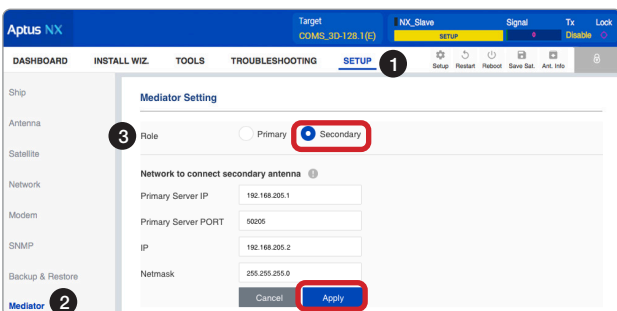

12.2.3 Performing Install Wizard

To control and manage both of the primary and secondary antenna systems, access the AptusNX with the Primary Antenna. Before starting the Dual Antenna System, perform the Install Wizard of the primary and secondary antenna system.

Performing Install Wizard for Primary Antenna System

To perform the Install Wizard of the primary antenna system, follow the steps below.

1. Assigning Active Antenna

Select **"Primary"** for the Antenna Active option. Click the **Apply** button to apply the settings to the system.

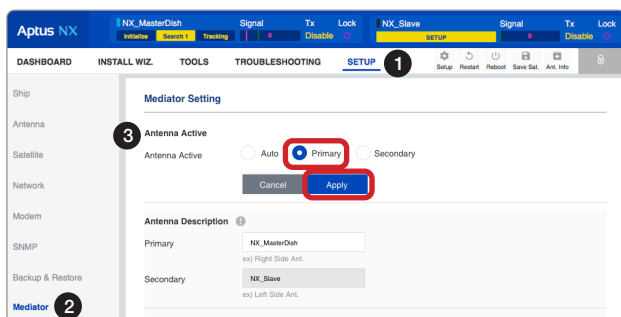

2. Performing Install Wizard

Perform the Install Wizard process. Refer to **"7.4 Starting Install Wizard"** on page 55 for more details.

Performing Install Wizard for Secondary Antenna System

To perform the Install Wizard of the secondary Tx antenna system, follow the steps below.

1. Assigning Active Antenna

Select **"Secondary"** for the Antenna Active option. Click the **Apply** button to apply the settings to the system.

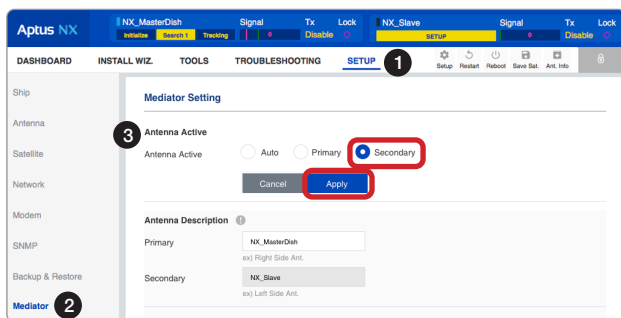

2. Performing Install Wizard

Perform the Install Wizard process. Refer to **"7.4 Starting Install Wizard"** on page 55 for more details.

Then, perform **"9.8.3 iARM Save & Reboot"** on page 91.

12.2.4 Monitoring Dual Antenna System

You can monitor the performance of the Dual Antenna System via AptusNX. The information of the primary and secondary antennas is shown on the Top Menu bar. On the Dashboard, the Dual Antenna Status, Primary Antenna, and Secondary Antenna panels are displayed for the monitoring.

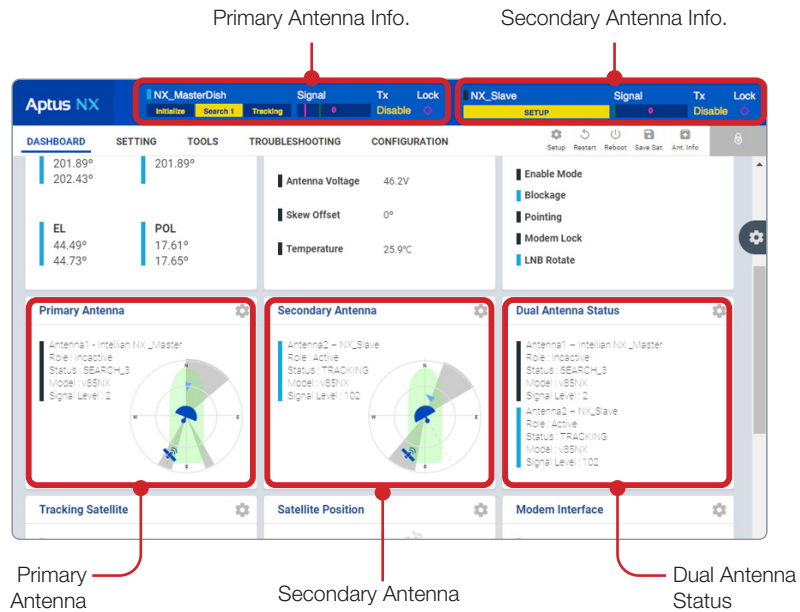

12.3 Appendix C. Important notice of waterproofing connector

12.3.1 Introduction

During antenna installation, it is important to ensure that once the cable is connected to the antenna, proper waterproofing of the connector must be done with a self-amalgamating tape.

If you need any assistance, please contact Intellian Technical Support (support@intelliantech.com).

12.3.2 Outline of taping

Self-amalgamating tape comes with a protective, plastic peel-away layer that allows the tape to be rolled and shipped. To waterproof a connector, you need to begin by peeling away a portion of this protective plastic layer and then start wrapping the tape around it.



12.3.3 Procedure

1. Connect the cable to the connector to be fully secured.



CAUTION

- DO NOT over-tighten the connector, nuts, or screws when mounting the antenna to prevent any damage.
- DO NOT leave any cables loose and non-fixed, especially for those installed outside of the antenna.

2. Apply tape over the connector.

It is important to wrap the cable onto itself and the best practice is to wrap the tape over itself by 50%, meaning that once you wrap your first layer your second layer should overlap over half of the first layer, and so on. This ensures that you get a strong bond between the different layers of tape that properly adhere to one another.

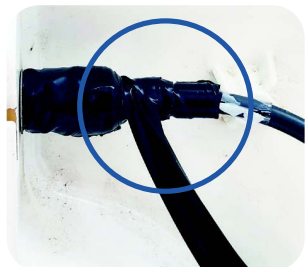

3. Ensure that the entire RF connector is taped up as shown in the picture right.





WARNING

- Note that you cannot use ordinary electrical tape to waterproof the RF connector. Only self-amalgamating tape is able to waterproof the connector properly.
- Failure to do so will result in rust and corrosion to the cable and its connector and this might end up damaging the antenna.