

SPACE42

THURAYA

MOBILE GATEWAY C NEO

Installation and user manual

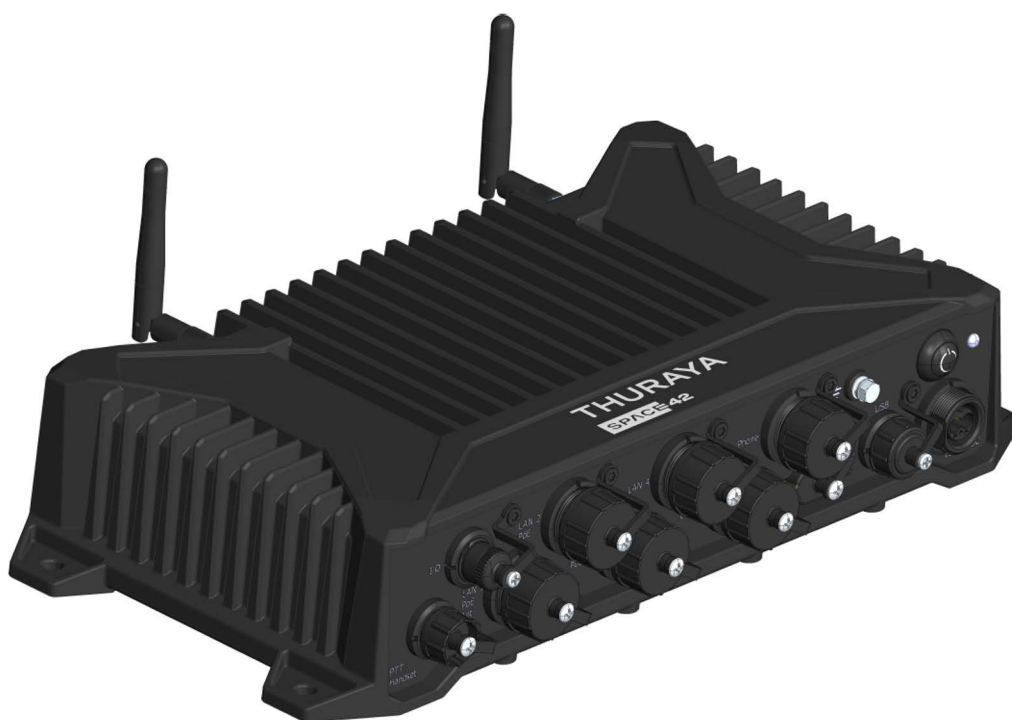

Model name and number: Mobile Gateway C NEO, 8050A

Document number: 98-188251-A

Release date: July 14, 2025

Disclaimer

Any responsibility or liability for loss or damage in connection with the use of this product and the accompanying documentation is disclaimed by Thrane & Thrane A/S. The information in this manual is provided for information purposes only, is subject to change without notice and may contain errors or inaccuracies. Manuals issued by Thrane & Thrane A/S are periodically revised and updated. Anyone relying on this information should acquire the most current version e.g. from the partner portal at <https://partnerportal.cobhamsatcom.com/eshop/downloads>, or from the distributor. Thrane & Thrane A/S is not responsible for the content or accuracy of any translations or reproductions, in whole or in part, of this manual from any other source. In the event of any discrepancies, the English version shall be the governing text.

Thrane & Thrane A/S is trading as Cobham Satcom.

Copyright

© 2025 Thrane & Thrane A/S. All rights reserved.

Manufacturer address

Thrane & Thrane A/S, Lundtoftegårdsvej 93D, DK-2800, Kgs. Lyngby, Denmark

WEEE (disposal)

Old electrical and electronic equipment marked with this symbol can contain substances hazardous to human beings and the environment. Never dispose these items together with unsorted municipal waste (household waste). In order to protect the environment and ensure the correct recycling of old equipment as well as the re-utilization of individual components, use either public collection or private collection by the local distributor of old electrical and electronic equipment marked with this symbol.



Contact the local distributor for information about what type of return system to use.

Safety summary

The following general safety precautions must be observed during all phases of operation, service and repair of this equipment. Failure to comply with these precautions or with specific warnings elsewhere in this manual violates safety standards of design, manufacture and intended use of the equipment. Thrane & Thrane A/S assumes no liability for the customer's failure to comply with these requirements.

Ground the equipment

For EMC reasons, the equipment must be connected to an electrical ground and the cable instructions must be followed.

Do not operate in an explosive atmosphere

Do not operate the equipment in the presence of flammable gases or fumes. Operation of any electrical equipment in such an environment constitutes a definite safety hazard.

Keep away from live circuits

Do not replace components with the power cable connected. Under certain conditions, dangerous voltages may exist even with the power cable removed. To avoid injuries, always disconnect power and discharge circuits before touching them.

Do not substitute parts or modify equipment

Because of the danger of introducing additional hazards, do not substitute any parts or perform any unauthorized modification to the equipment.

Power supply

The equipment must be supplied by external power sources rated:

- 12 VDC, max range 10.8-15.6 VDC or
- 24 VDC, max range 21.6-33.6 VDC

About this manual

Intended readers

This is an installation and user manual for the Mobile Gateway C NEO, intended for installers of the system, service personnel and users.

Personnel installing or servicing the system must be properly trained and authorized by Cobham Satcom. It is important that you observe all safety requirements listed in the beginning of this manual, and install the system according to the guidelines in this manual and in the included Installation guide.

Manual overview

This manual has the following chapters and appendices:

- *Introduction*
- *Installation*
- *To get started*
- *Maintenance and troubleshooting*
- *Specifications*
- *Conformity*

Related documents

The below list shows the documents related to this manual and to the Mobile Gateway C NEO system.

Refer to the Thuraya PRISM PTT+ Portal or the Cobham Satcom Partner Portal for additional documentation, tech notes etc.

Title and description	Document number
Mobile Gateway C NEO Installation guide	98-188252
IP NEO C User manual	98-188239
Voyager NEO User & Installation manual	98-188241

Table 0-1: Related documents

Typography

In this manual, typography is used as indicated below:

Bold is used for the following purposes:

- To emphasize words.
Example: “Do **not** touch the terminal during transmission”.
- To indicate what the user should select in the user interface.
Example: “Select **Terminal settings**”.

Italic is used to emphasize the paragraph title in cross-references.

Example: “For further information, see *Connecting Cables* on page...”.

COURIER is used for the following purposes:

- To indicate text appearing in a display.
Example: “the Main screen shows **READY**”.
- To indicate low level commands such as AT commands.
Example: “In your terminal program, type **ATD**”.

Table of contents

Chapter 1	Introduction	
1.1	What is the Mobile Gateway C NEO?	1-1
1.2	The Mobile Gateway C NEO unit	1-5
Chapter 2	Installation	
2.1	What's in the box	2-1
2.2	Before installation	2-2
2.3	Physical installation	2-2
2.4	Connecting cables	2-4
2.5	PTT connection examples	2-14
Chapter 3	To get started	
3.1	Authentication and initial configuration	3-1
3.2	To start up the system	3-1
3.3	To test the system	3-3
Chapter 4	Maintenance and troubleshooting	
4.1	Software update of Mobile Gateway C NEO	4-1
4.2	Status signaling	4-2
4.3	Troubleshooting	4-5
4.4	Tracking and location reporting	4-5
4.5	To reset the Mobile Gateway C NEO	4-5
4.6	To create a diagnostic report	4-6
4.7	Certificates	4-7
Appendix A	Specifications	
A.1	General specifications	A-1
A.2	Interface specifications	A-1
Appendix B	Conformity	
B.1	CE	B-1
B.2	RCM, Australia	B-1
B.3	Safety CB certificate	B-1
B.4	FCC	B-2
Glossary	Glossary-1
Index	Index-1

List of figures

Chapter 1	Introduction	
	Figure 1-1: System overview (example).....	1-2
	Figure 1-2: Local and external connections.....	1-3
	Figure 1-3: Buttons, LED and connectors.....	1-5
Chapter 2	Installation	
	Figure 2-1: Physical installation.....	2-2
	Figure 2-2: Outline drawing with dimensions.....	2-3
	Figure 2-3: Ground connection.....	2-4
	Figure 2-4: Power cable, pinout and wire colors.....	2-5
	Figure 2-5: Power connection.....	2-5
	Figure 2-6: Cable for Voyager NEO or Orion NEO satellite terminal.....	2-6
	Figure 2-7: Connector for satellite terminal.....	2-7
	Figure 2-8: USB C connector.....	2-8
	Figure 2-9: Ethernet connectors.....	2-8
	Figure 2-10: WLAN antennas.....	2-9
	Figure 2-11: Where to connect Thuraya PTT Handset.....	2-10
	Figure 2-12: Where to connect an analog phone.....	2-10
	Figure 2-13: Where to connect an IP handset.....	2-10
	Figure 2-14: Where to connect speaker, ringer and/or E&M radio.....	2-11
	Figure 2-15: I/O cable, pinout and wire colors.....	2-11
	Figure 2-16: Serial interface (RS-232, DB9 connector).....	2-13
	Figure 2-17: Serial connector (RS-232) pinout.....	2-13
	Figure 2-18: Simple PTT connection example.....	2-14
Chapter 3	To get started	
Chapter 4	Maintenance and troubleshooting	
	Figure 4-1: Light indicator (LED).....	4-2
Appendix A	Specifications	
Appendix B	Conformity	

List of tables

	Table 0-1: Related documents.....	iii
Chapter 1	Introduction	
Chapter 2	Installation	
	Table 2-1: Speaker interface pinout and wire colors.....	2-11
	Table 2-2: Ringer interface pinout and wire colors.....	2-12
	Table 2-3: Audio interface pinout and wire colors.....	2-12
	Table 2-4: PTT interface pinout and wire colors.....	2-12
Chapter 3	To get started	
	Table 3-1: Startup sequence in LEDs and PTT handset.....	3-2
Chapter 4	Maintenance and troubleshooting	
	Table 4-1: LED indications.....	4-2
	Table 4-2: Messages in Thuraya PTT Handset display.....	4-3
Appendix A	Specifications	
	Table A-1: General specifications.....	A-1
	Table A-2: Interface specifications.....	A-1
Appendix B	Conformity	

Introduction

1.1 What is the Mobile Gateway C NEO?

Mobile Gateway C NEO is an AES-256 encrypted IP-based data communications device which can be used in a portable configuration placed anywhere or, more common, mounted in vehicles or vessels. It adds support for additional interfaces such as RJ11 (phone), multiple Ethernet ports (with and without Power over Ethernet (PoE)), USB and RS232, and it features Voice-over-IP technologies optimized for use under satellite link conditions. The Mobile Gateway also hosts the client part of the PTT application with interface to the Thuraya PTT Handset and Space42 IP Handset, and support for external speaker and microphone. It supports Maritime/Land Mobile Radio integration and it features Cobham Satcom's unique PRISM PTT+ technology supporting satellite/WLAN/LAN/LTE backhaul.

1.1.1 Features and interfaces

The Mobile Gateway C NEO has the following features and interfaces:

- Optimized for use with satellite terminals from the Thuraya NEO series.
- Connects to Thuraya PTT Handset.
- Analog (RJ11) phone interface.
- WLAN, both client and access point. Configurable in the Thuraya PRISM PTT+ Portal.
- 5 Ethernet ports,
 - one with PoE (PSE) Type 4/Class 8 (for satellite terminal),
 - two with PoE (PSE) Type 1/Class 2 (for IP handsets) and
 - two standard 10/100/1000 Mbps LAN ports.
- USB interface for software update, diagnostic report or external LTE modem.
- I/O interface for speakers, ringers and radio integration.
- Serial interface.
- Support for external battery.
- Connection management with PRISM.
- AES-256 encryption.

1.1.2 Overview of a typical Mobile Gateway C NEO system

There are a number of possible system configurations. The example below shows a Mobile Gateway C NEO system using a Voyager NEO satellite terminal to create a unified network using PRISM (refer to the next section).

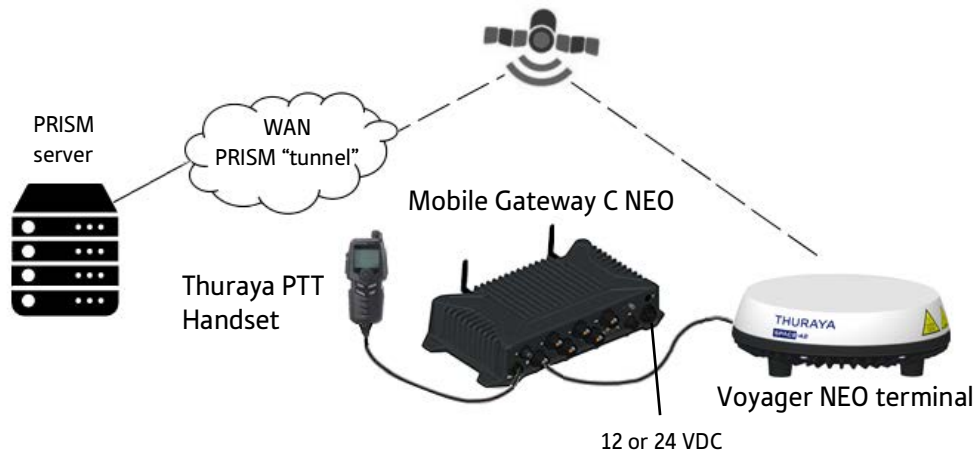

Figure 1-1: System overview (example)

1.1.3 Combining external networks with PRISM

Private Routing and Intelligent System Management (PRISM) is a hybrid communications system combining WLAN, LAN, LTE and satellite connectivity to increase resilience and coverage. It is a user-friendly voice and data solution turning various networks into one unified network.

PRISM routes all traffic to and from the Mobile Gateway C NEO through an AES-256 encrypted multi-path tunnel between the terminal and a server, using satellite, LAN or WLAN connectivity. Depending on server routing, devices attached to the Mobile Gateway C NEO will have direct access to services on the server and beyond.

1.1.4 Local and external connections to the Mobile Gateway C NEO

The Mobile Gateway C NEO communicates on the external network through the PRISM server. It has the following means of communication:

External connections	Local connections
Satellite terminal, e.g., Voyager NEO	Thuraya PTT Handset
WLAN (configured as client and within reach of a WLAN access point)	E&M radio (connected to I/O interface)
LAN connected to a router with access to the Internet.	WLAN (configured as access point)
USB cellular modem ¹	LAN connected to e.g., a PC or IP handset
	USB local device
	Analog phone (POTS)

1. For supported modems, refer to the partner portal at partnerportal.cobhamsatcom.com.

Figure 1-2: Local and external connections

1.1.5 Configuration

The administrator of your Mobile Gateway C NEO system prepares the system configuration on the server, using the Thuraya PRISM PTT+ Portal. When the Mobile Gateway C NEO connects to the network for the first time, it will go through an authentication process and will contact the server to get its configuration.

Thuraya PRISM PTT+ Portal

The Thuraya PRISM PTT+ Portal is the access point for configuration, provisioning etc. of your Mobile Gateway C NEO system.

The system administrator can create different users with different access levels. See the manuals for the Thuraya PRISM PTT+ Portal for information on how to use the portal.

We recommend connecting to the server for authentication and initial configuration **before** installing the Mobile Gateway C NEO units.

Thuraya PTT Handset

Apart from PTT communication, you can use the Thuraya PTT Handset to switch the system on and off and for minor setup and status.

The following information is accessible on the handset display:

- Satellite modem state and signal level.
- Current Call Group.
- List of Call Groups in Call Group mode.
- Phone book with list of users that can be dialed directly.
- Connectivity state.
- Current Speaker if any.
- Handset Volume level.
- Handset background light level.
- Handset Key Lock status.
- Active Events. Severity and description.
- External Audio and External Speaker state.
- Secondary Call Group state.
Indicates whether Call Groups with priority 2 is enabled.
- Configured Alias.
- Serial Number.
- Firmware Version.

Configuration of connected equipment

For Cobham Satcom equipment, e.g., IP NEO C or other satellite terminals, the system configuration is done from the Thuraya PRISM PTT+ Portal.

For 3rd party external equipment, refer to the Cobham Satcom Partner Portal at partnerportal.cobhamsatcom.com.

1.2 The Mobile Gateway C NEO unit

1.2.1 Overview of the unit

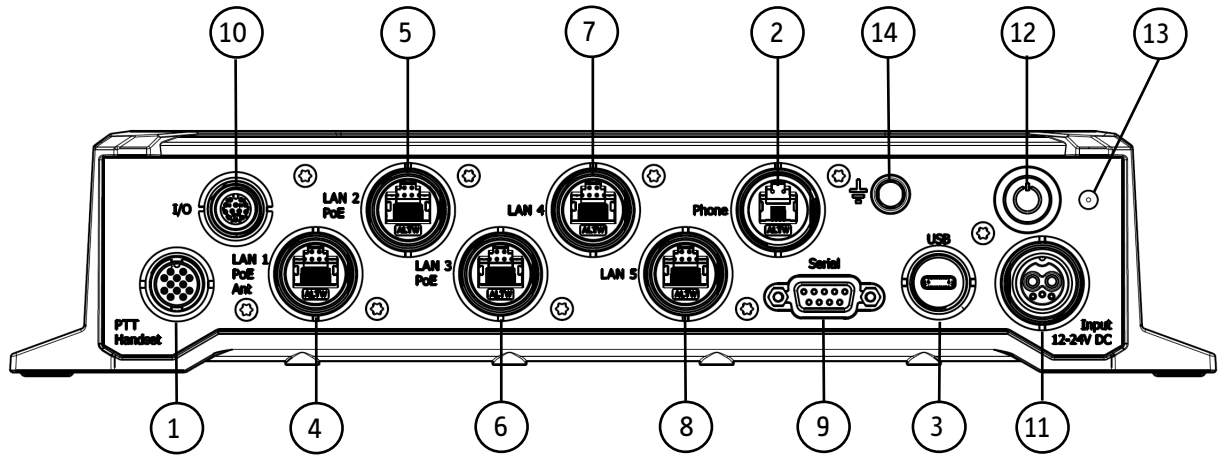

Figure 1-3: Buttons, LED and connectors

Connectors:

1. PTT Handset: Connects to the Thuraya PTT Handset.
2. Phone: Connects to a standard POTS phone (RJ11 connector).
3. USB: USB-C 3.0 for USB LTE modems, software update or diagnostic logs.
4. LAN1 PoE Ant: Ethernet with PoE Type 4/Class 8 dedicated to connection and power supply to a satellite terminal from the Thuraya NEO series.
5. LAN 2 PoE: Ethernet with PoE Type 1/Class 2 for connection to e.g. IP handset.
6. LAN 3 PoE: Same as 5.
7. LAN 4: Standard Ethernet 10/100/1000 Mbps connection.
8. LAN 5: Same as 7.
9. Serial: Serial port for RS-232.
10. I/O: I/O pins for external speakers, ringers and radio integration
11. DC-Input (12 or 24 VDC nominal): Input from DC supply and Ignition. See *To connect input power* on page 2-5.
12. Power: On/Off button.
13. Status LED.
14. Grounding bolt, for connection to Ground.

Installation

2.1 What's in the box

The following items are included in the delivery of your Mobile Gateway C NEO:

- Mobile Gateway C NEO unit
- Power cable with connector at one end, the other open-ended
- 2 WLAN antennas
- Installation guide

2.2 Before installation

2.2.1 Configuration

Before installation, the administrator of your Mobile Gateway C NEO system must prepare the system configuration on the server, using the Thuraya PRISM PTT+ Portal. When the Mobile Gateway C NEO connects to the network for the first time, it goes through an authentication process and contacts the server to get its configuration. For details, see *Authentication and initial configuration* on page 3-1.

Note Before installing the Mobile Gateway C NEO, we recommend connecting it via the Ethernet interface to a DHCP-enabled router to authenticate and get the initial configuration from the server, so that it is ready for use when installed e.g. in a vehicle.

2.3 Physical installation

2.3.1 Mobile Gateway C NEO installation

The Mobile Gateway C NEO is designed to be mounted on a wall e.g. in a vehicle.

Note In order to protect the connectors on the Mobile Gateway C NEO from physical damage, mount the Mobile Gateway C NEO vertically with the connectors facing downwards.

When placing the Mobile Gateway C NEO, make sure there is enough space to access cables and to see the status of the LED. You can find the dimensions of the Mobile Gateway C NEO in Figure 2-2.

Mount the Mobile Gateway C NEO with 4 pcs. M5x12 mm screws (or M4.8x25 mm self-tapping screws) through the 4 mounting holes. Screw head: Max height 3.7 mm, max. diameter 9.5 mm (according to ISO 14583 M5 size)

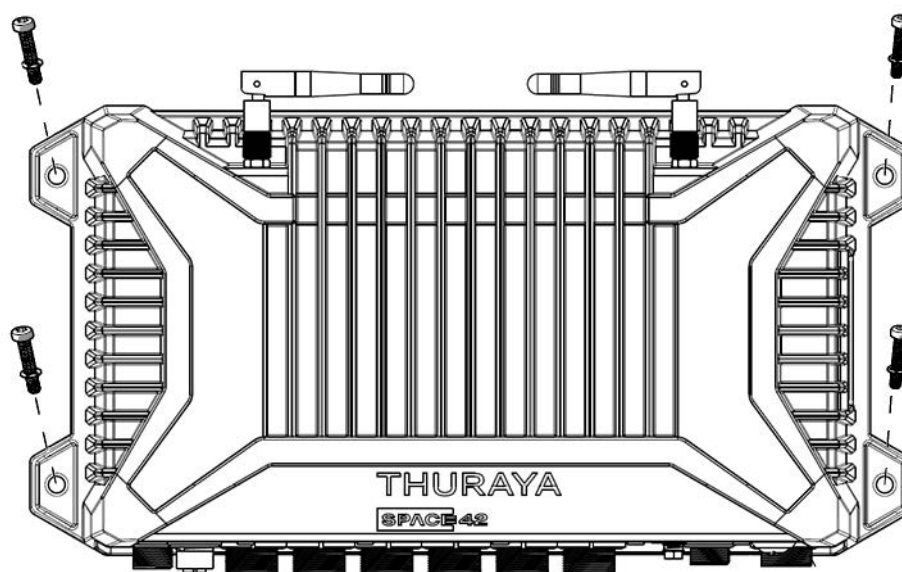

Figure 2-1: Physical installation

2.3.2 Outline drawing with dimensions

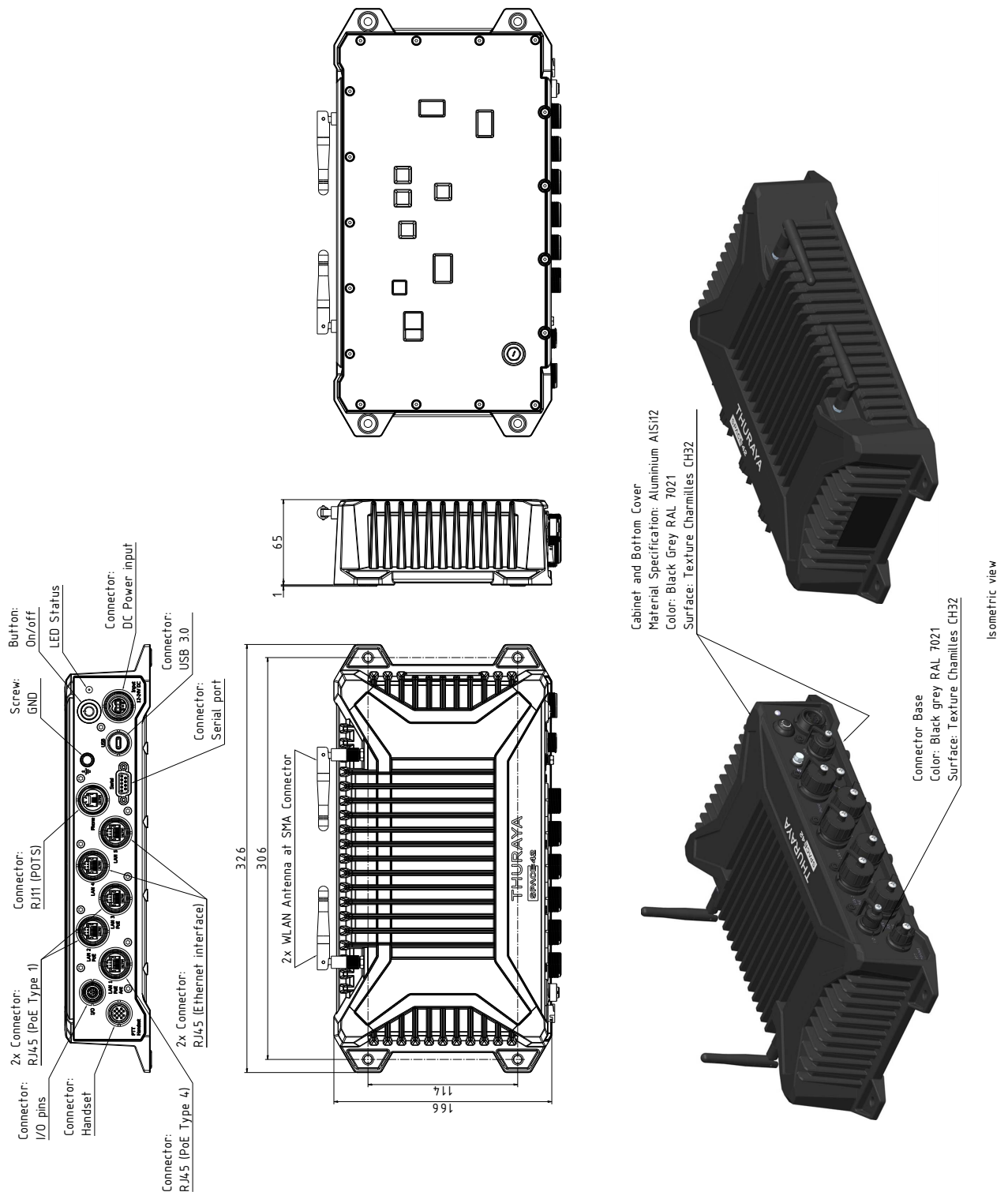

Figure 2-2: Outline drawing with dimensions

2.3.3 Handset installation

There are 3 types of handset that connect to the Mobile Gateway C NEO: Thuraya PTT Handset, Space42 IP Handset and standard analog phone.

Note When two or more of the above handset types are present and used at the same time, there is a risk of acoustic feedback from one handset into the other. Place the handsets further apart if you have these feedback issues.

Install the handsets according to their manuals, taking into consideration the distance between the handsets. Connect the handsets as described in section 2.4.7, 2.4.8 and 2.4.9 on page 2-10.

2.4 Connecting cables

2.4.1 To connect ground

The Mobile Gateway C NEO has a ground connection point next to the power button. Do as follows to connect your ground cable:

1. Crimp a ring terminal to your grounding cable (AWG17-AWG16 cable).
2. Unscrew the grounding bolt.
3. Place the ring terminal over the grounding bolt.
4. Remount and fasten the grounding bolt with the ring terminal and washer.
5. Connect the other end of the grounding cable to chassis ground of the vehicle or vessel.

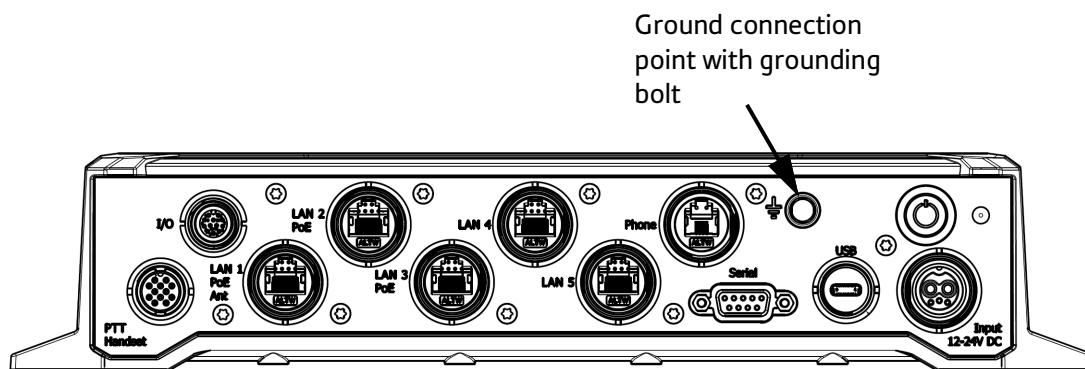
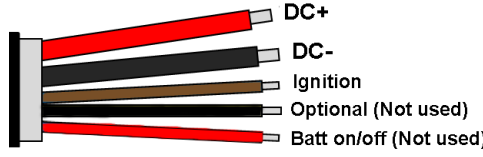

Figure 2-3: Ground connection

2.4.2 To connect input power

The delivery includes a short, open-ended power cable for connection to DC power and ignition.



Pin	Function	Wire color	Size (AWG)
1	DC+	Red	12
2	DC-	Black	12
3	Ignition	Brown	26
4	Optional	Black	26
5	Batt on/off	Red	26

Figure 2-4: Power cable, pinout and wire colors

1. Connect the DC+, DC- and Ignition wires in the cable to **power and ignition** as described below.



CAUTION! Do not connect directly to the vehicle battery! Connect to the dedicated 12 or 24 VDC output and ignition signal in the vehicle/vessel.



CAUTION! The power cable from the vehicle must be externally fused with a 30 A fuse.



CAUTION! When connecting other equipment to the same power supply, be aware that the standard upper voltage limit for 24 VDC systems is **31.2 VDC**, even though the max range for the Mobile Gateway C NEO goes up to 33.6 VDC.

- Connect the thick red wire (DC+) to V+.
 - Connect the thick black wire (DC-) to V-.
 - Connect the thin brown wire (Ignition) to the Ignition signal in the vehicle/vessel.
 - Cut off unused wires as close as possible to the cable insulation. If necessary, cover the unused wire ends with insulating tape.
2. When your installation is ready, connect the other end of the power cable to the connector marked **Input 12-24V DC** on the Mobile Gateway C NEO.

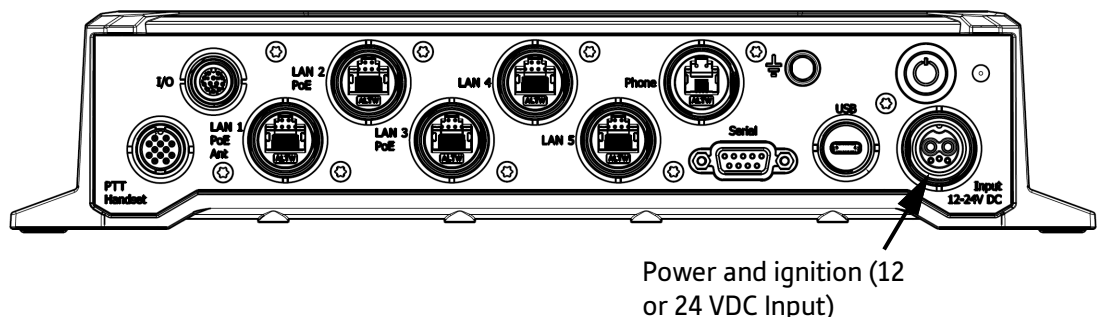

Figure 2-5: Power connection

2.4.3 To connect to a satellite terminal

Cables

- For Voyager NEO or Orion NEO satellite terminal:
Acquire a dedicated LAN/PoE cable for Voyager NEO or Orion NEO. The cable has a dedicated connector for Voyager NEO or Orion NEO at one end and is open-ended at the other end. After leading the cable, mount an RJ45 connector at the open end of the cable according to Figure 2-6 below and add a special protective connector housing. Contact your supplier for the protective connector housing.

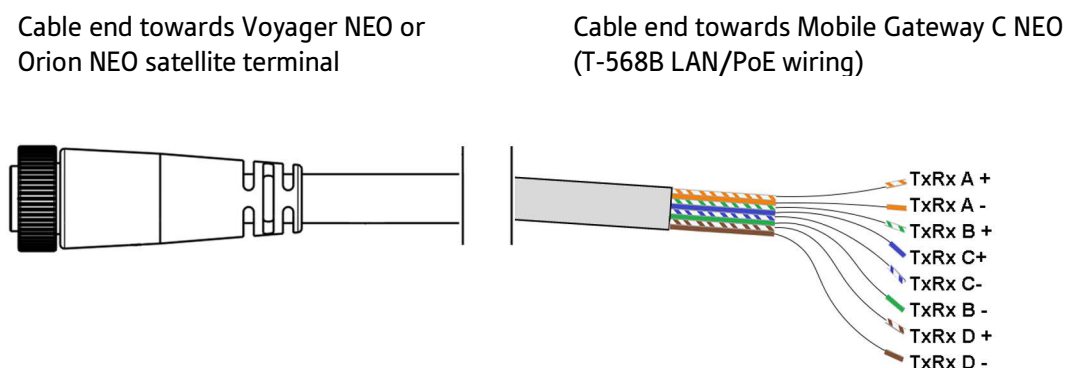

Figure 2-6: Cable for Voyager NEO or Orion NEO satellite terminal.

- For IP NEO C satellite terminal, you can use a standard LAN/PoE cable, min. cat. 5E or cat. 6A, in the length needed for your installation.

Note You may want to leave one end of the cable open until you have completed the cable routing in your installation.

For ingress protection, the cable must have special protective connector housings at both ends of the cable. The dedicated cable for Voyager NEO or Orion NEO is already protected at one end. Contact your supplier for separate protective connector housings matching the Mobile Gateway C NEO (and the IP NEO C if needed).

Mount the protective connector housings on the cable, one for each connector.

Voyager NEO or Orion NEO satellite terminal

1. Install the satellite terminal as described in the manual for the satellite terminal.
2. Connect the LAN/PoE cable (described in *Cables* above) between the satellite terminal and the Mobile Gateway C NEO connector marked **LAN1 PoE Ant.**

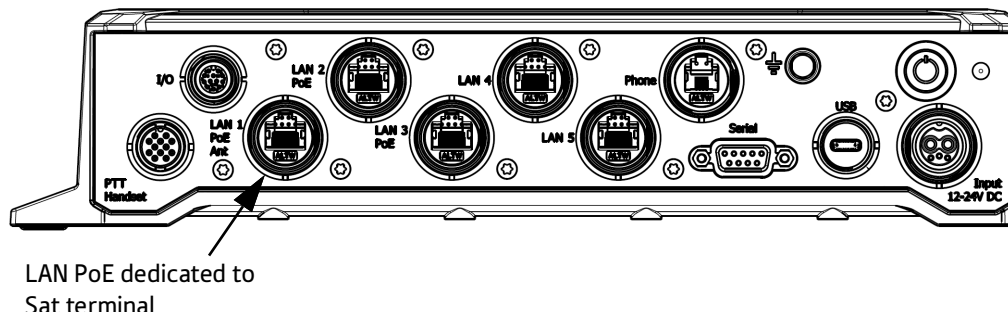

Figure 2-7: Connector for satellite terminal

3. If you are using protective connector housings, screw them on tightly when connecting the satellite terminal and the Mobile Gateway C NEO, in order to maintain the ingress protection against water and dust.

IP NEO C satellite terminal

To connect an IP NEO C terminal to the Mobile Gateway C NEO, you have two options:

1. **LAN and PoE power:** Connect the LAN/PoE cable (described in *Cables* above) between the IP NEO C connector marked **LAN PoE In** and the Mobile Gateway C NEO connector marked **LAN1 PoE Ant**.

The IP NEO C will then be supplied with power (PoE) from the Mobile Gateway C NEO together with the LAN connection.

or

LAN only. The IP NEO C has an internal battery, which can be charged by connecting a separate power supply or external battery to the DC input on the IP NEO C:

- Connect a LAN cable (min. Cat. 5E or Cat. 6A) between a LAN connector on the IP NEO C and a LAN connector on the Mobile Gateway C NEO. For ingress protection, see *Cables* on page 2-6.
 - When the battery of the IP NEO C needs recharging, connect the IP NEO C DC input to a power source as described in the IP NEO C manual.
2. If you are using protective connector housings, screw them on tightly when connecting the satellite terminal and the Mobile Gateway C NEO, in order to maintain the ingress protection against water and dust.

2.4.4 USB interface

The Mobile Gateway C NEO has a **USB C Type 3.0** connector for:

- USB cellular modems. Refer to partnerportal.cobhamsatcom.com for details (search for Mobile Gateway C NEO).
- Software update, see *To update software via USB* on page 4-1.
- Diagnostic report, see *To create a diagnostic report* on page 4-6.

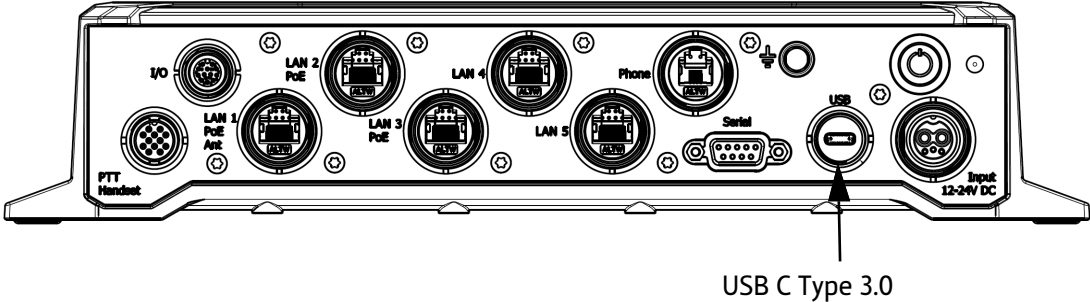

Figure 2-8: USB C connector

2.4.5 Ethernet interface

The Mobile Gateway C NEO has 5 Ethernet connectors.

- LAN1 PoE Ant: Ethernet with PoE Type 4/Class 8 dedicated to connection of a satellite terminal.
- LAN 2 PoE: Ethernet with PoE Type 1/Class 2 for connection to IP handset.
- LAN 3 PoE: Same as LAN 2 PoE.
- LAN 4: Standard Ethernet 10/100/1000 Mbps connection.
- LAN 5: Same as LAN 4.

See specifications in *Interface specifications* on page A-1.

The Ethernet interface can be used e.g., for connection to a PC, an IP handset or other IP equipment.

Note If you connect the Ethernet interface to a DHCP-enabled router, be aware that this will **disable the data routing functionality** of the Mobile Gateway C NEO, which means that all data traffic from local units will go through the DHCP-enabled router, and **not** through any connected satellite terminals. This only applies to data, voice is not affected.

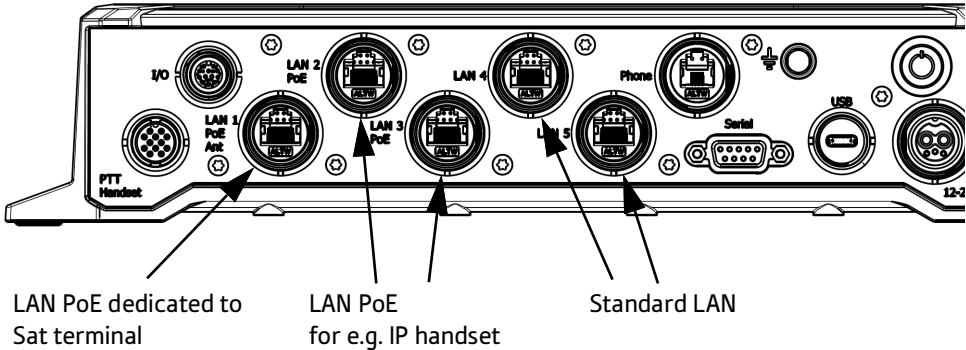

Figure 2-9: Ethernet connectors

2.4.6 To connect WLAN antennas

The Mobile Gateway C NEO has a built-in WLAN module for wireless communication devices. To use the WLAN interface, you must mount one or two WLAN antennas on the Mobile Gateway C NEO (WLAN antennas are included in the delivery package).

WLAN antennas

The Mobile Gateway C NEO is certified with WLAN antennas from Kyocera AVX, part number X9001091-W3DRMB. If you are using another WLAN antenna, the max. gain of the antenna must be no more than 3.32 dBi at 2.4 GHz and 4.41 dBi at 5 GHz.

To use the WLAN interface, you must first connect one or two WLAN antennas to the connectors marked **Wi-Fi (Main and Div)**.

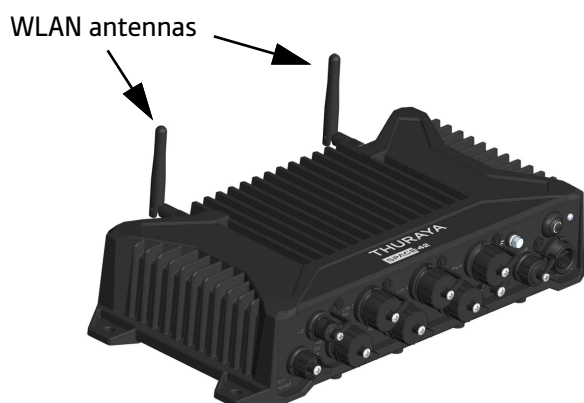

Figure 2-10: WLAN antennas

If only one antenna is used, connect it to the connector marked **Main**.

For details on how to install the antenna(s), see the documentation for your WLAN antenna.

Note

The WLAN module can be configured in the Thuraya PRISM PTT+ Portal to be

- an **access point** to which you can connect wireless devices
- a **WLAN client** that can be connected to an external WLAN access point.

2.4.7 To connect the Thuraya PTT Handset

The Thuraya PTT Handset can be used for communication in PTT systems, and for showing status for the system. See also *Handset installation* on page 2-4.

1. Connect the cable from the Thuraya PTT Handset to the connector marked **PTT Handset** on the Mobile Gateway C NEO.

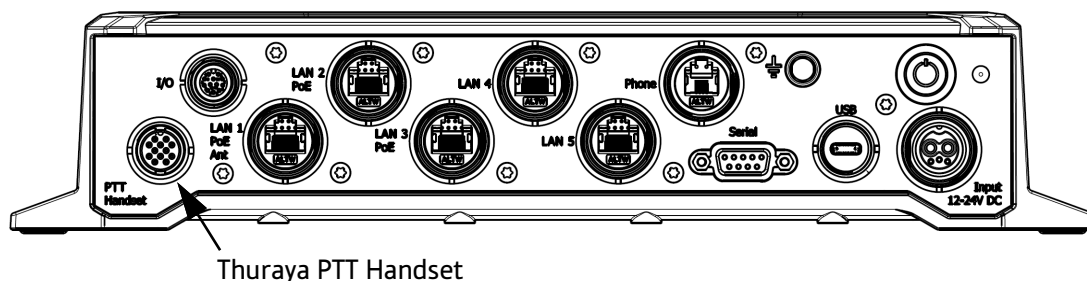

Figure 2-11: Where to connect Thuraya PTT Handset

2. When the Mobile Gateway C NEO is switched on, the Thuraya PTT Handset automatically turns on and shows the status of the system.

2.4.8 To connect an analog phone

1. Connect the cable from your analog phone (RJ11 connector) to the connector marked **Phone** on the Mobile Gateway C NEO. See also *Handset installation* on page 2-4.

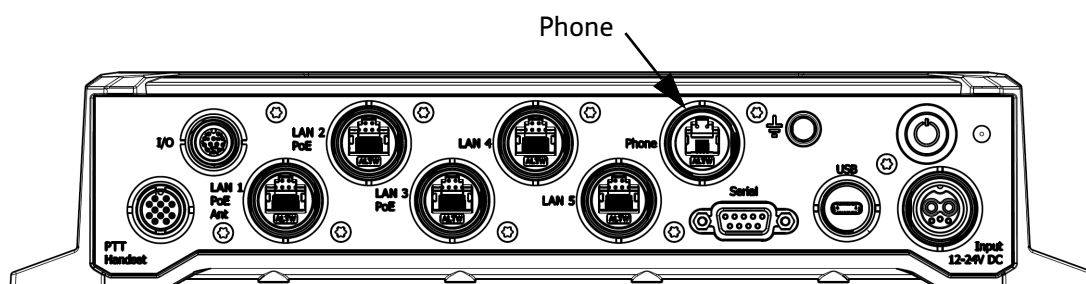

Figure 2-12: Where to connect an analog phone

2. When the Mobile Gateway C NEO is switched on and there is a connection through a satellite terminal to the satellite network, the phone can be used to make a call.

2.4.9 To connect an IP handset

Connect your IP handset to one of the Ethernet connectors. Use **LAN2 PoE** or **LAN3 PoE** if the IP handset is to be powered by PoE. See also *Handset installation* on page 2-4.

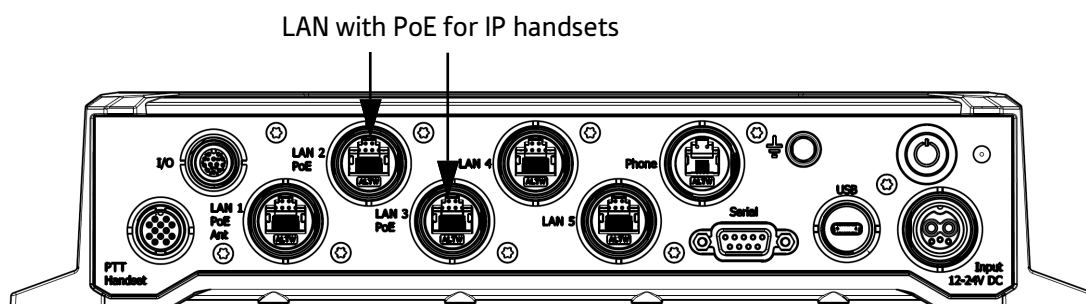

Figure 2-13: Where to connect an IP handset

2.4.10 I/O interface

The I/O interface can be used to connect:

- External speaker
- Ringer
- E&M radio

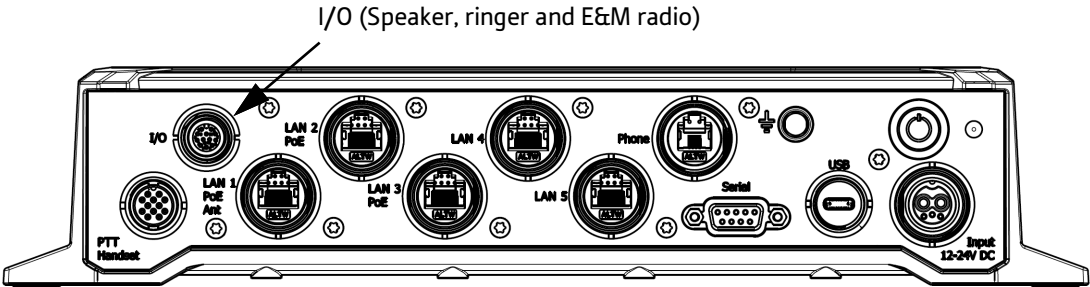
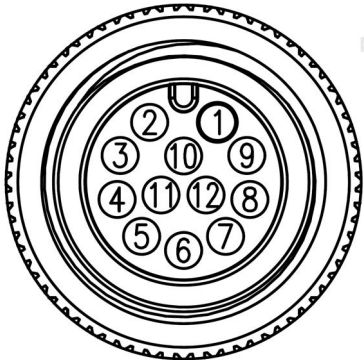

Figure 2-14: Where to connect speaker, ringer and/or E&M radio

Cable: Acquire a dedicated I/O cable for the Mobile Gateway C NEO from your supplier. The drawing below shows the pinout and wire colors for the cable.



Pin	Function	Wire color
1	Speaker+	White
2	Speaker-	Brown
3	Ringer+	Green
4	Ringer-	Yellow
5	GND	Gray
6	12 VDC I/O	Pink
7	Input A (PTT)	Blue
8	Input B (GPI)	Red
9	Output A (PTT)	Black
10	Output B (GPO)	Violet
11	Audio in	Gray/Pink
12	Audio out	Red/Blue

Figure 2-15: I/O cable, pinout and wire colors

To connect a speaker

For specifications for the Speaker interface, see *Speaker* on page A-2.

1. Connect your external speaker to the Speaker wires in the I/O cable:

Signal in connected speaker	Wire color	Pin in Mobile Gateway C NEO
Input +	White	Pin 1 (Speaker Out+)
Input -	Brown	Pin 2 (Speaker Out-)

Table 2-1: Speaker interface pinout and wire colors

To connect a ringer

For specifications for the Ringer interface, see *Ringer* on page A-2.

1. Connect your ringer device to the Ringer wires in the I/O cable:

Signal in connected ringer	Wire color	Pin in Mobile Gateway C NEO
Trigger signal +	Green	Pin 3 (Ringer+)
Trigger signal -	Yellow	Pin 4 (Ringer-)

Table 2-2: Ringer interface pinout and wire colors

To connect a radio

For specifications for the radio interface, see *Audio* on page A-2.

1. Connect the radio device to the Audio wires in the I/O cable:

Signal in connected radio	Wire color	Pin in Mobile Gateway C NEO
Audio output+	Gray/Pink	Pin 11 (Audio in)
Audio GND	Gray	Pin 5 (GND)
Audio input+	Red/Blue	Pin 12 (Audio out)
Audio GND	Gray	Pin 5 (GND)

Table 2-3: Audio interface pinout and wire colors

2. Connect the radio's PTT interface:

Signal in connected radio	Wire color	Pin in Mobile Gateway C NEO
PTT output	Blue	Pin 7 (Input A)
PTT input	Black	Pin 9 (Output A)
GND	Gray	Pin 5 (GND)

Table 2-4: PTT interface pinout and wire colors

2.4.11 Serial interface

The serial interface can be used for RS-232 serial communication.

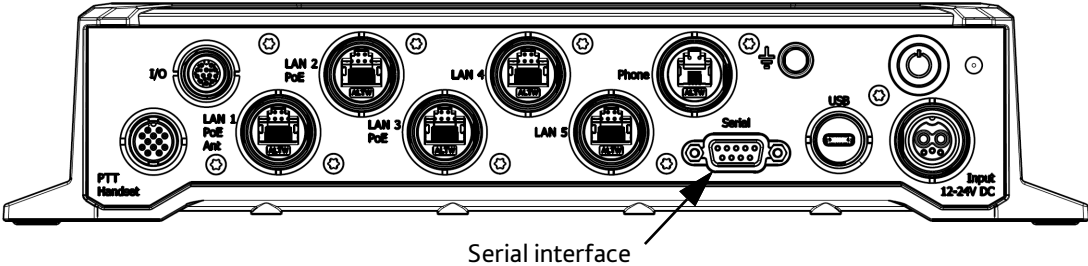
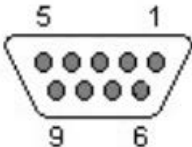

Figure 2-16: Serial interface (RS-232, DB9 connector)



DB-9 Female

Pin	Function
1	NC
2	Rx
3	Tx
4	NC
5	GND
6	NC
7	NC
8	NC
9	NC

Figure 2-17: Serial connector (RS-232) pinout

2.5 PTT connection examples

2.5.1 Basic PTT example

Below is an example of a basic PTT system with a NEO satellite terminal, a Thuraya PTT Handset and a Mobile Gateway C NEO.

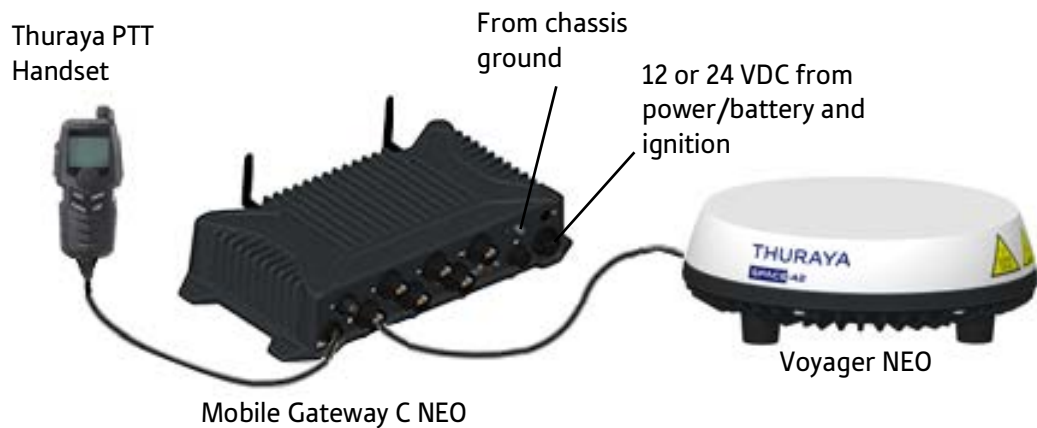

Figure 2-18: Simple PTT connection example

With this setup you can use your PTT communication over satellite, using the Voyager NEO satellite terminal.

1. Connect the power wires from the Mobile Gateway C NEO as described in *To connect input power* on page 2-5.
2. Connect the cable from the Voyager NEO to the Mobile Gateway C NEO as described in *To connect to a satellite terminal* on page 2-6.
3. Connect the Thuraya PTT Handset to the PTT Handset connector in the left side of the connector panel on the Mobile Gateway C NEO.
4. When the Mobile Gateway C NEO is powered, authenticated and connected to the satellite network, you are ready to use your PTT system.

To get started

3.1 Authentication and initial configuration

Before starting up the system, the initial configuration must be done on the server using the Thuraya PRISM PTT+ Portal. Usually the administrator of the system takes care of this in cooperation with the partner supplying the system.

When the system is configured on the Thuraya PRISM PTT+ Portal and the Mobile Gateway C NEO is turned on, the Mobile Gateway C NEO will automatically search for a DHCP server on the Ethernet interface. If a DHCP server is not found, it will search for a connected Thuraya satellite terminal. When the DHCP server or satellite terminal is found, the Mobile Gateway C NEO will contact the server for authentication and initial configuration.

3.2 To start up the system

3.2.1 To switch on the system

- Turn on the ignition of the vehicle/vessel to switch on the system, or
- If you have a Thuraya PTT Handset connected, push the power button at the top of the handset to switch on the handset and the Mobile Gateway C NEO system.

When the system is switched on, it goes through a startup sequence, as shown on the next page.

3.2.2 Startup sequence

When the Mobile Gateway C NEO is switched on, the LED blinks yellow (booting) and then turns steady yellow when power is ready. The connection status is shown in the LED and in the Thuraya PTT Handset (if connected) as follows:

Status	Thuraya PTT Handset, display	LED
Initiating (after boot)	Startup icon "System init" (briefly)	Yellow constant
Searching for new software on USB	"Search USB for new software" If new software is found: "Install vX.YY-Z?"	-
Setting up modems	"Setting up modems"	Green blinking
Getting configuration from server.	"Get config"	Green blinking
Waiting for PTT network	"Setting up network"	Green blinking
Ready	<Call group> (Ready - Ring...)	Green constant
Connected	<Call group> "Conn"	Green constant

Table 3-1: Startup sequence in LEDs and PTT handset display

Connection ready

If you have connected a Thuraya PTT Handset, it will show the status and signal strength of the satellite connection.

The LED on the Mobile Gateway C NEO is green when a connection (satellite, LTE, WLAN and/or LAN) is ready for communication.

3.3 To test the system

3.3.1 Test audio

1. Check that there are no warnings, e.g. in the display of the Thuraya PTT Handset.
2. Make a PTT call to an established PTT call group or client and check that audio is coming through.
3. Remove all external network connections except one and check that you still get audio through the system.
4. Repeat step 3 with every external network connection (satellite, WLAN etc.) to check that they are all working.

3.3.2 Test data

1. Connect a PC to one of the **LAN** connectors on the Mobile Gateway C NEO.
2. Check that you can get data through the system. The method to do this depends on your configuration, whether you have special data routing, access to the Internet or not, etc. For example if you have configured your system to have access to the Internet, you can open a browser and access a dependable Internet site.
3. Remove all external network connections except one and check that you can still get data through the system.
4. Repeat step 3 with every external network connection to check that they are all working.

Maintenance and troubleshooting

4.1 Software update of Mobile Gateway C NEO

4.1.1 Policy for software download and installation

On the Thuraya PRISM PTT+ Portal you can set up policies for download and installation of software. For example, you can set up the Mobile Gateway C NEO to only download software when it is connected via cellular network or a local connection.

If you want the software to be installed immediately after download, you can set a “Force software update” flag in the Thuraya PRISM PTT+ Portal. When this flag is set, the software will be downloaded and installed immediately after.

If this flag is **not** set, you will be prompted in the Thuraya PTT Handset to confirm installation of the software. When you have confirmed, the software will be installed. If you do not confirm, the software will be installed at next reboot of the Mobile Gateway C NEO.

4.1.2 To update software over the air

1. If there is a new software version on the server, the Mobile Gateway C NEO will automatically download the software when it connects to the network, if the policy defined in the Thuraya PRISM PTT+ Portal allows it.
2. If a Thuraya PTT Handset is connected, you may be asked if you want to install the software immediately. If you ignore this, or if a Thuraya PTT Handset is not connected, the downloaded software is automatically installed next time the Mobile Gateway C NEO is rebooted.

If needed, you can also force an immediate software update from the Thuraya PRISM PTT+ Portal.

4.1.3 To update software via USB

Note You can only install software from USB if you have a Thuraya PTT Handset connected, because the system needs confirmation from the user.

Note Before you can confirm the software installation, the LAN interface of the Mobile Gateway C NEO must be connected to an NTP server to get the correct date and time. If the Mobile Gateway C NEO is not connected to the Internet, it must be connected to a local NTP server instead. The IP address (or host name) of the local NTP server must be the same as for the NTP server set up in the PTT server infrastructure.

1. If a USB flash drive is connected to the USB connector when the Mobile Gateway C NEO starts up, the Mobile Gateway C NEO will automatically look for software on the USB flash drive.
2. If the software version in the USB flash drive is different from the currently active software version, you will be prompted in the Thuraya PTT Handset to confirm installation of the software.
3. Confirm the software update using the Thuraya PTT Handset.

The software will now be installed.

4.2 Status signaling

4.2.1 LED functions

There is one LED on the Mobile Gateway C NEO.



Figure 4-1: Light indicator (LED)

The table below shows the functions of the LED.

LED status	Description
● Green constant	Connected
● Green blinking	Setting up connection
● Yellow constant	The Mobile Gateway C NEO is powered and ready, but there is no network connection.
● Yellow blinking	Booting
● Blue blinking	Software update in progress
● Red constant	Error
○ Off	Power off

Table 4-1: LED indications

4.2.2 Messages in Thuraya PTT Handset display

The following list shows the error messages that can appear in the display of the Thuraya PTT Handset.

Note All configuration is done in the Thuraya PRISM PTT+ Portal. For configuration issues, check in the portal that the system is set up correctly.

Display	Severity	Description
Config, No modems	Warning	No modems are configured.
No PIN code found	Warning	PIN is missing for satellite terminal.
PUK code required	Error	PUK code required for satellite terminal.
Ethernet cable disc.	Warning	Ethernet cable not connected. Please check cable and connected devices.
Modem SIM locked	Error	SIM locked. Please check configuration. Reboot to try again.
Config, No IMSI	Error	Configuration error. IMSI required.
Config, No APN	Error	Configuration error. APN required.
Config, no Thuraya sat.	Error	The "Thuraya sat" setting is missing in the configuration.
Config, no Name	Error	Configuration error. Modem name required.
Config, no Type	Error	Configuration error. Modem type required.
No telnet IP	Warning	Configuration error. Telnet IP required for PPPoE modem.
Telnet logon failure	Warning	Unable to login to PPPoE modem using telnet.
Network stalled	Warning	Network stalled. No data can be sent on any modem. Might be locked or out of coverage.
Poor LAN quality!	Warning	LAN connection is too unstable and cannot be used.
Establish secure tunnels	Information	Establishing secure MPP tunnels using available online modems. If modems comes online after the tunnels are established, they will still be used.
No serial number	Error	Info of serial number missing in the unit.
No device type	Error	Info of device type missing in the unit.

Table 4-2: Messages in Thuraya PTT Handset display

Display	Severity	Description
Config Server Err.	Error	Unable to fetch configuration from either primary or secondary server.
Fetch Stage 1 config	Information	Fetching new SSL certificate and Stage 2 server IP address from Stage 1 server. A LAN connection or a satellite terminal is required.
Check Stage 2 config	Information	Check if configuration has been changed on the primary Stage 2 server and download if it has.
Check Stage 2 config	Information	Check if configuration has been changed on the secondary Stage 2 server and download if it has.
Synchronizing time	Information	Fetch NTP time from Stage 2 or Stage 1 server. Correct system time is necessary for SSL to succeed.
Invalid config	Error	Invalid configuration
FW update blocked	Warning	Over the air firmware update is not allowed on any modems. Please use USB update or change the configuration.
FW update failed	Error	Firmware update failed
Ext. 12V overload	Warning	Overload on the 12 V output in the I/O connector.
New FW ready	Notice	New firmware ready
Modems	Information	Local configuration found. The specified modems will be used. The first modem that comes online will be used for initial check/download of configuration.
Using modem	Information	Using specified modem to update system time and check/download configuration.
System Information	Information	Overview of current system configuration and status
Invalid Thuraya	Error	Invalid satellite terminal detected. PTT Can be used with following terminals: Voyager NEO, Orion NEO and IP NEO C
FW download failed	Error	Error downloading firmware:

Table 4-2: Messages in Thuraya PTT Handset display (Continued)

4.3 Troubleshooting

If an error occurs, first check if there are any error messages e.g., in the display of the Thuraya PTT Handset. See *Messages in Thuraya PTT Handset display* on page 4-3 for explanations for the error messages.

If you cannot solve the problem, you can create a diagnostic report, see *To create a diagnostic report* on page 4-6, to help you troubleshoot the problem.

4.4 Tracking and location reporting

You can set up the Mobile Gateway C NEO to report its position to a server at certain time intervals or after moving a given distance.

To use the tracking feature you must either set up a tracking server or get a tracking solution from your service provider. The Mobile Gateway C NEO must be set up in the Thuraya PRISM PTT+ Portal to match this server. Once set up on both sides, the Mobile Gateway C NEO will send position reports to the server as specified.

4.5 To reset the Mobile Gateway C NEO

You can reset the Mobile Gateway C NEO using the Thuraya PTT Handset.

Note After reset to factory defaults, the Mobile Gateway C NEO must connect to the server to authenticate and get the configuration. This procedure is the same as for a new unit. See *Authentication and initial configuration* on page 3-1.

4.5.1 Reset with the Thuraya PTT Handset

To reset the Mobile Gateway C NEO to factory defaults from the Thuraya PTT Handset, do as follows:

1. **During startup** of the Mobile Gateway C NEO, hold down the **Shift** button on the Thuraya PTT Handset until you are asked whether you want to reset to factory defaults.
2. Push the **center selector button** on the handset to confirm the reset. The Mobile Gateway C NEO will reset to factory defaults. This means that any configuration downloaded, including the Stage 2 server IP addresses will be deleted. If you do not confirm the reset within 10 seconds, the system will return to normal operation without resetting. If you push the **Home** button instead of confirming, the reset will also be canceled.

4.6 To create a diagnostic report

The diagnostics report contains relevant information for troubleshooting. When contacting your supplier for support, please enclose this file. You can create a diagnostic report in two ways:

- Initiated by the Thuraya PTT Handset
- Initiated from the Thuraya PRISM PTT+ Portal

Using the **Thuraya PTT Handset**:

1. Depending on your setup, connect the Mobile Gateway C NEO to the PRISM PTT+ server or connect a USB memory stick to the USB interface of the Mobile Gateway C NEO.
2. Press the **Home** button on the Thuraya PTT Handset for 2 seconds, until the display shows `Generate Diagnostic Report?`.
3. Press the central button to acknowledge.
4. Turn the selector wheel until the display shows what you want to do with the report. You can select **Upload to USB?** or **Upload to server?**.
5. Press the central button to acknowledge.

The display shows `Uploading` until complete. The diagnostic report is uploaded as a **tar.gz** file containing various diagnostic files.

Using **Thuraya PRISM PTT+ Portal** you can request a diagnostic report and download it to the server. For details, refer to the documentation for the Thuraya PRISM PTT+ Portal.

4.7 Certificates

For information on the Thuraya PRISM PTT+ Portal, see the manuals for the Thuraya PRISM PTT+ Portal.

4.7.1 To acquire and renew the certificate

When the Mobile Gateway C NEO connects to the server for the first time, it sends information about itself and acquires a certificate from the server over a TLS (HTTPS) connection. This certificate is used for provisioning. The certificate is automatically renewed at regular intervals, when the Mobile Gateway C NEO connects to the server.

4.7.2 Replacement of a unit

The configuration of each Mobile Gateway C NEO unit is saved on the server. When you need to replace a unit, your administrator uses the Thuraya PRISM PTT+ Portal to enter the new unit as a duplicate of the existing unit in the system. When the Mobile Gateway C NEO unit is replaced, the new terminal is automatically recognized as a duplicate and receives a new certificate from the server.

Note

The old unit is not revoked automatically when the new unit is installed. If you want the old unit revoked, the administrator must log into the Thuraya PRISM PTT+ Portal and revoke the unit.

4.7.3 Revocation

If a Mobile Gateway C NEO is lost, the certificate can be revoked, so that this Mobile Gateway C NEO can no longer connect to the server and identify itself. Contact your supplier for revocation.

Appendices

Specifications

A.1 General specifications

Item	Specifications
Dimensions	Height: 65 mm Width: 326 mm Depth: 166 mm
Weight	2.7 kg (6 lbs)
Operating temperature	-21°C to +55°C
Storage temperature	-40°C to +85°C
Ingress Protection	IP55
Power consumption	Max. 172 W with all outputs loaded

Table A-1: General specifications

A.2 Interface specifications

Specifications of the connectors on the Mobile Gateway C NEO.

Interface	Specifications
DC input	1 x PWR connector, 13/16"-28UNS thread. 12 VDC Nominal, max range 10.8 VDC to 15.6 VDC. 24 VDC Nominal, max range 21.6 VDC to 33.6 VDC. ¹

Table A-2: Interface specifications

1. **Caution:** Any **other** connected equipment for vehicular use may only support up to **31.2 VDC**, which is the standard upper voltage limit for 24 VDC systems.

Interface	Specifications
LAN 1-5	<p>5 x RJ45 connectors, 13/16"-28UNS thread.</p> <ul style="list-style-type: none"> • LAN 1 PoE Ant is for connecting and supplying a satellite terminal. IEEE802.3bt Type 4/Class 8. Supports 90 W output @ 54 V. • LAN 2 PoE and LAN 3 PoE are for connecting and (optionally) supplying power to e.g. an IP handset. IEEE 802.3af Type 1/Class 2. Supports 7 W output @ 54 V. • LAN 4 and LAN 5 are standard 10/100/1000 Mbps Base-T LAN ports for connecting a PC or other IP equipment.
USB	<p>1 x USB 3.0 Type C connector (host), 5/8"-27UNS thread. 1 A @ 5 V, current limited to 1000 mA.</p>
I/O <ul style="list-style-type: none"> • Speaker • Ringer • Audio • GPI/GPO 	<p>12-pin female M12 connector.</p> <ul style="list-style-type: none"> • Min. 5 W, 8 Ohm (functional range: 4-16 Ohm). <ul style="list-style-type: none"> • Bandwidth: 300 Hz to 3 kHz. • Frequency response: +1 dB to -3 dB (300-3 kHz, 0 dB@1 kHz). • Steep roll off <200 Hz and >4 kHz • THD max 5%. • Trigger signal on incoming calls: <ul style="list-style-type: none"> • Ringer+: 12 VDC limited to 100 mA. • Ringer-: Open Collector limited to 750 mA and 32 VDC. • E&M radio interface incl. PTT in/out: <ul style="list-style-type: none"> • Line out: 600 Ohm / Range: 250-750 mV RMS. • Line in: 10 kOhm / Range: 5 mV-750 mV RMS. • Bandwidth: 300 Hz to 3 kHz. • Frequency response: +1 dB to -3 dB (300-3 kHz, 0 dB@1 kHz). • SNR > 40 dB@Ref=94 dBA. • THD+N<5%. • Not used <ul style="list-style-type: none"> GPI: 0 - 39 VDC, low level 0.9 VDC GPO: 0 - 32 VDC, Max. load 500 mA
PTT Handset	<p>12-pin male connector, 5/8"-27UNS bayonet lock, for Thuraya PTT Handset.</p>
Phone	<p>1 x RJ11 connector, 13/16"-28UNS thread, for connecting POTS phone/equipment.</p>
Serial	<p>1 x D-Sub 9-pin female connector. Supports RS-232.</p>
WLAN antenna interface	<p>2 x SMA male connectors (Main and Div). 802.11ac/a/b/g/n - bidirectional. Max. gain: 3.32 dBi at 2.4 GHz and 4.41 dBi at 5 GHz.</p>

Table A-2: Interface specifications (Continued)

Conformity

Certificates of approval will be available in partnerportal.cobhamsatcom.com, or from your supplier.

B.1 CE

The Mobile Gateway C NEO is CE certified as stated in the “EU Declaration of Conformity”.
The WLAN interface is CE certified through the manufacturer of the WLAN card.

B.2 RCM, Australia

The Mobile Gateway C NEO is RCM certified as stated in the “Certificate/Declaration of Conformance RCM”.

B.3 Safety CB certificate

The Mobile Gateway C NEO is certified as stated in the CB Test Certificate.

B.4 FCC

FCC e-label:

Model: 8050A

Thuraya Mobile Gateway C NEO

FCC ID: ROJ-8050A

Contains FCC ID: ZWM-M2-6398SV

Note: This equipment has been tested and found to comply with the limits for a Class A digital device, pursuant to part 15 of the FCC Rules. These limits are designed to provide reasonable protection against harmful interference when the equipment is operated in a commercial environment. This equipment generates, uses and can radiate radio frequency energy and, if not installed and used in accordance with the instruction manual, may cause harmful interference to radio communications. Operation of this equipment in a residential area is likely to cause harmful interference in which case the user will be required to correct the interference at his own expense.

NOTICE:

This device complies with Part 15C and part 15E of the FCC Rules.

Operation is subject to the following two conditions:

- (1) this device may not cause harmful interference, and
- (2) this device must accept any interference received, including interference that may cause undesired operation.

NOTICE:

Changes or modifications made to this equipment not expressly approved by Cobham Satcom may void the FCC authorization to operate this equipment.

A

- AES-256** AES stands for Advanced Encryption Standard and is a specification for the encryption of electronic data established by the U.S. National Institute of Standards and Technology (NIST) in 2001. The -256 part is the key length in bits.
- APN** Access Point Name. The Access Point Name is used by the terminal operator to establish the connection to the required destination network.

D

- DHCP** Dynamic Host Configuration Protocol. A protocol for assigning dynamic IP addresses to devices on a network. With dynamic addressing, a device can have a different IP address every time it connects to the network.

E

- E&M radio** E and M signaling is a type of supervisory line signaling that uses DC signals on separate leads, called the "E" lead and "M" lead, traditionally used in the telecommunications industry between telephone switches.
- EMC** Electromagnetic Compatibility

H

- HTTPS** Hypertext Transfer Protocol Secure

I

- I/O** Input/output
- IMSI** International Mobile Subscriber Identity. A unique number used to identify a mobile subscriber on a wireless network.
- IP** Internet Protocol

L

- LAN** Local Area Network
- LED** Light Emitting Diode
- LTE** Long-Term Evolution (also called 4G), a standard for wireless communication of high-speed data for mobile phones and data terminals.

N

- NC** Not Connected

P

- PC** Personal Computer
- PIN** Personal Identification Number. A code number used to provide access to a system that has restricted access.
- PoE** Power over Ethernet. A standard for combining power supply with transmission of data over

the Ethernet. The source unit injects power into the Ethernet cable and the power is picked up at the connected device.

POTS	Plain Old Telephony System. Traditional 2-wire system.
PRISM	Private Routing & Intelligent System Management. A technology used for dual operation with cellular and satellite network to obtain seamless and transparent data transfer independent of the network used (Cellular or satellite backup connection).
PSE	Power Sourcing Equipment
PTT	Push-To-Talk. A means of instantaneous communication commonly employed in wireless cellular phone services that uses a button to switch a device from voice transmission mode to voice reception mode. Multiple parties to the conversation may also be included.
PUK	Pin Unblocking Key. An eight-digit code used to unblock a SIM card after three incorrect pin codes have been entered. The PUK code is supplied with the SIM card.

T

THD	Total Harmonic Distortion
TLS	Transport Layer Security is the upgraded version SSL, which is a communication protocol for secure communication. TLS authenticates more efficiently and continues to support encrypted communication channels.

U

USB	Universal Serial Bus. An industry standard that specifies cables, connectors and protocols for connection, communication and power supply (interfacing) between computers, peripherals and other computers.
-----	---

W

WAN	Wide Area Network. A telecommunications network or computer network that extends over a large geographical distance. In this context mostly used for a satellite or cellular network as opposed to e.g., a LAN.
WLAN	Wireless LAN

A	
About the Mobile Gateway C NEO	1-1
acoustic feedback	2-4
acquire certificate	4-7
analog phone	
connection	2-10
installation	2-4
antenna	
WLAN connect	2-9
approvals	B-1
authentication	3-1
C	
certificate for authentication	4-7
acquire or renew	4-7
compliance	B-1
configuration	1-3
connected equipment	1-4
initial	3-1
conformity	B-1
connect Orion NEO	2-7
connections	
overview of local and external	1-3
connectors	
I/O (radio, ringer and speaker)	2-11, 2-12
LAN	2-8
overview	1-5
Phone (RJ11)	2-10
power and Ignition	2-5
Thuraya PTT Handset	2-10
USB	2-8
contents of delivery	2-1
D	
diagnostics	
create report	4-6
dimensions	
drawings	2-3
dimensions and weight	A-1
documents, related	-iii
E	
Ethernet connectors	2-8
F	
factory default	
reset using Thuraya PTT Handset	4-5
features	1-1
feedback	
acoustic between handsets	2-4
H	
handset	
physical installation	2-4
I	
Ingress Protection (IP grade)	A-1
initial configuration	3-1
installation	
handsets	2-4
Mobile Gateway C NEO	2-2
interface specifications	A-1
IP handset	
connect	2-10
installation	2-4
L	
LAN interface	2-8
LED	
functions	4-2
M	
messages in Thuraya PTT Handset display	4-3
Mobile Gateway	
replace	4-7
revoke	4-7
system overview	1-2
O	
operating temperature	A-1
Orion NEO satellite terminal	
connect	2-7
outline drawings	2-3
P	
phone	
connect analog (POTS)	2-10
installation	2-4
power consumption, typical	A-1
power input	
connect	2-5
PRISM	
combining networks	1-2
PTT connection examples	2-14

R

radio	
connect	2-12
renew certificate	4-7
replace a Mobile Gateway unit	4-7
reset to factory defaults	
from Thuraya PTT Handset	4-5
revocation of a Mobile Gateway unit	4-7
ringer	
connect	2-12

S

safety summary	-ii
satellite terminal	
connect Voyager NEO	2-7
software update	
in Mobile Gateway	4-1
Space42 IP Handset	
connect	2-10
installation	2-4
speaker	
connect	2-11
specifications	A-1
startup sequence	3-2
storage temperature	A-1
switch on	3-1

T

temperature	
operating	A-1
storage	A-1
test, initial	3-3
Thuraya PTT Handset	
connect	2-10
functions	1-4
installation	2-4
messages in display	4-3
tracking	4-5
troubleshooting	4-5
typography used in this manual	-iv

U

update software	
from USB drive	4-1
in Mobile Gateway	4-1
over the air	4-1
USB interface	2-8

V

Voyager NEO satellite terminal	
connect	2-7

W

weight and dimensions	A-1
WLAN antennas	
connect	2-9

